



US00D713301S

(12) **United States Design Patent**
Haviland

(10) **Patent No.:** **US D713,301 S**

(45) **Date of Patent:** **** Sep. 16, 2014**

(54) **ADJUSTABLE SLIDING LINK ASSEMBLY
FOR HEIGHT CONTROL OF AIR
SUSPENSION SYSTEMS FOR VEHICLES**

(75) Inventor: **Robin L. Haviland**, Dayton, OH (US)

(73) Assignee: **Dayton Air Control Products LLC**,
Dayton, OH (US)

(**) Term: **14 Years**

(21) Appl. No.: **29/395,798**

(22) Filed: **Apr. 2, 2012**

(51) **LOC (10) Cl.** **12-16**

(52) **U.S. Cl.**
USPC **D12/159**

(58) **Field of Classification Search**
USPC D23/385-395, 397, 370-373, 365, 354,
D23/399-403, 421, 499; 454/309, 275-277,
454/284, 287-291, 358-363; 52/302.1,
52/32.07; 285/229, 189, 183, 123.1, 15,
285/114, 110, 424, 197; D12/159, 160;
280/5.5-5.524, 124.1, 124.111,
280/124.116, 124.107
See application file for complete search history.

(56) **References Cited**

U.S. PATENT DOCUMENTS

2,126,408	A *	8/1938	Peo	74/579 R
3,110,486	A *	11/1963	Brenner	267/71
3,736,010	A *	5/1973	Larkin	403/104
4,385,754	A *	5/1983	Waite	267/71
5,186,486	A *	2/1993	Hynds et al.	280/124.107

5,595,452	A *	1/1997	Hill et al.	403/221
5,853,051	A *	12/1998	Buchanan et al.	172/824
6,019,383	A *	2/2000	Kociba et al.	280/124.134
6,056,069	A *	5/2000	Hagen et al.	172/679
6,161,451	A *	12/2000	Gleason, II	74/579 R
6,354,614	B1 *	3/2002	Ham et al.	280/124.11
6,609,575	B1 *	8/2003	Crabb	172/439
7,048,071	B1 *	5/2006	Huenink et al.	172/439
D543,492	S *	5/2007	Lyew	D12/159
D545,246	S *	6/2007	Kroeker	D12/159
7,398,984	B2 *	7/2008	Tucker	280/124.116
D651,947	S *	1/2012	Hsu	D12/159
D694,158	S *	11/2013	Dunlap et al.	D12/159

* cited by examiner

Primary Examiner — David Muller

(74) *Attorney, Agent, or Firm* — Jacox, Meckstroth & Jenkins

(57) **CLAIM**

The ornamental design of an adjustable sliding link assembly for height control of air suspension systems for vehicles, as shown and described.

DESCRIPTION

FIG. 1 is a perspective view of an adjustable sliding link assembly for height control of air suspension systems for vehicles showing my new design;
FIG. 2 is an end view thereof, the opposite end view being the same;
FIG. 3 is a front view thereof;
FIG. 4 is a side view thereof;
FIG. 5 is a rear view thereof; and,
FIG. 6 is an opposite side view thereof.

1 Claim, 2 Drawing Sheets

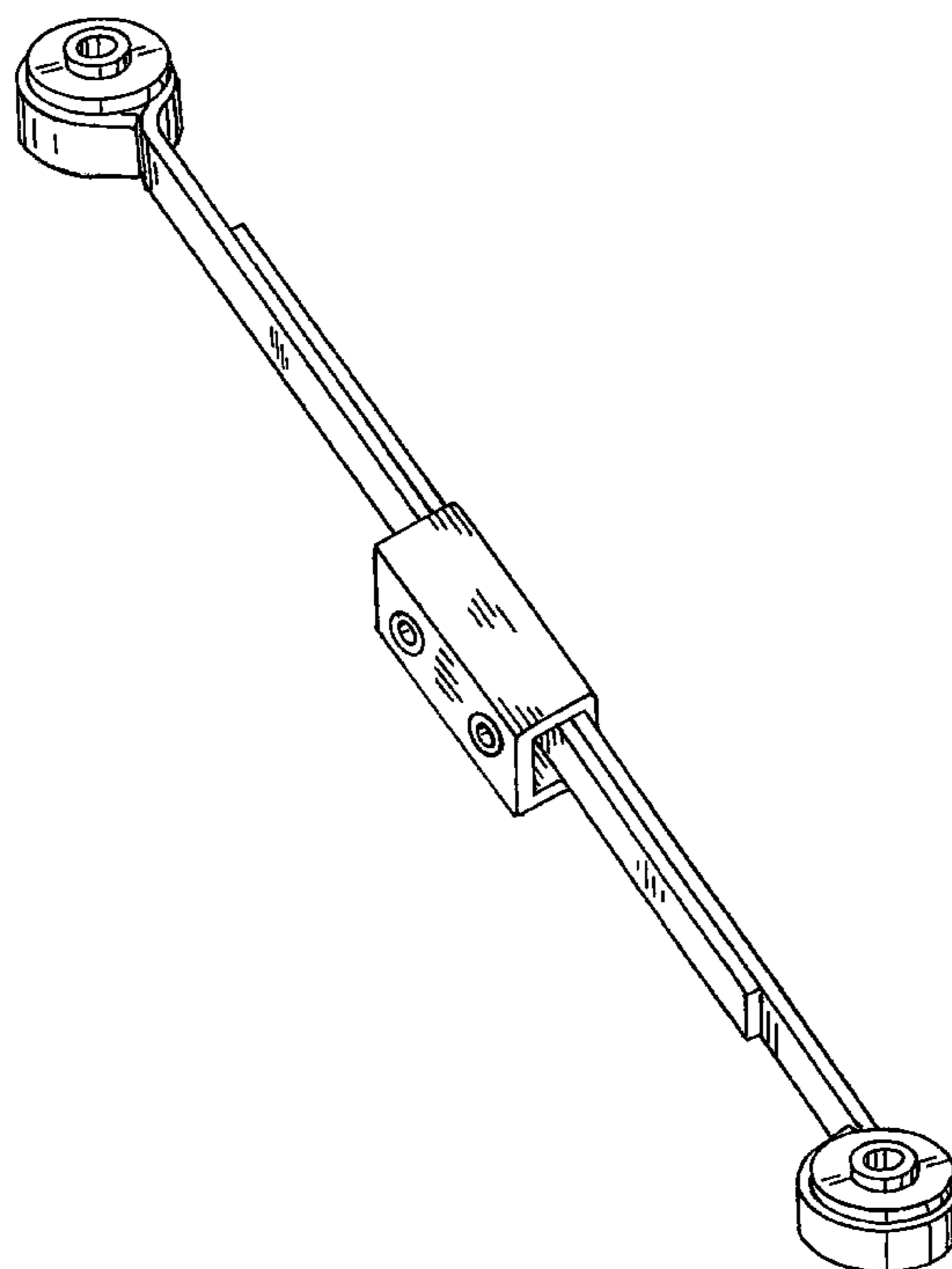

FIG. 1

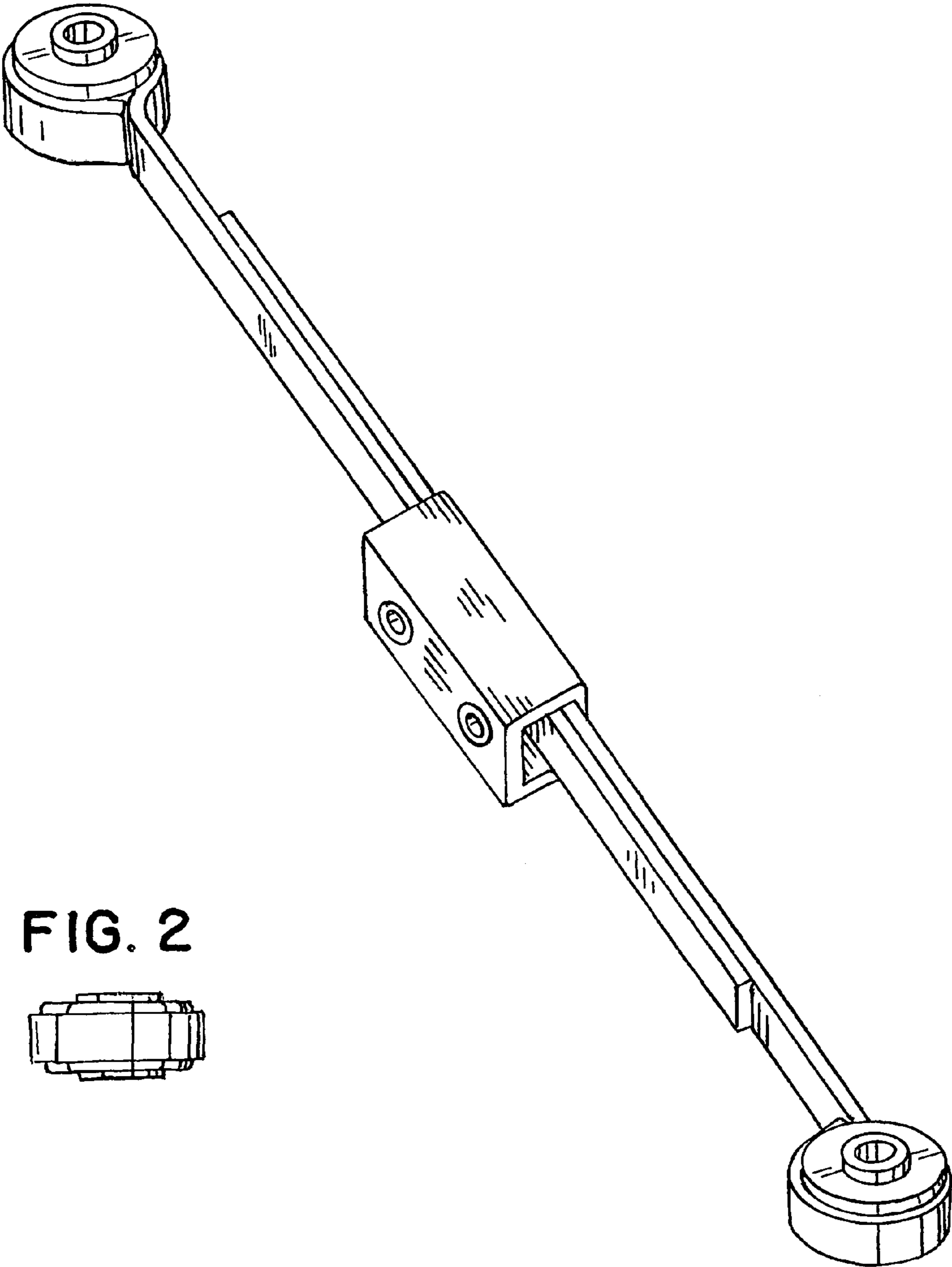

FIG. 2

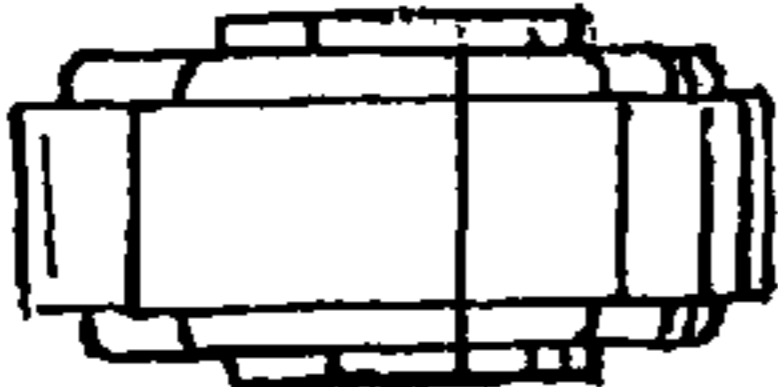

FIG. 3

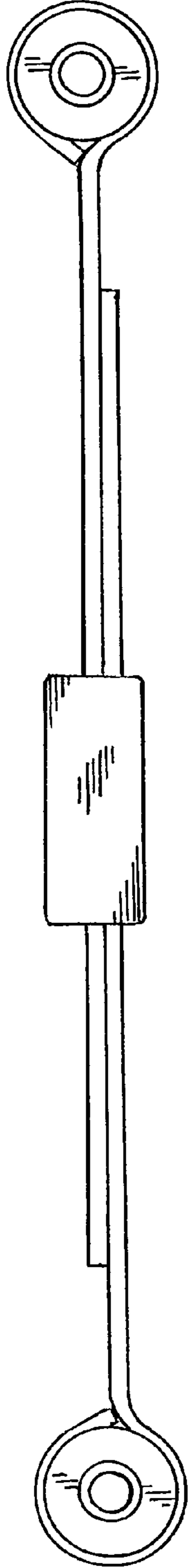

FIG. 4

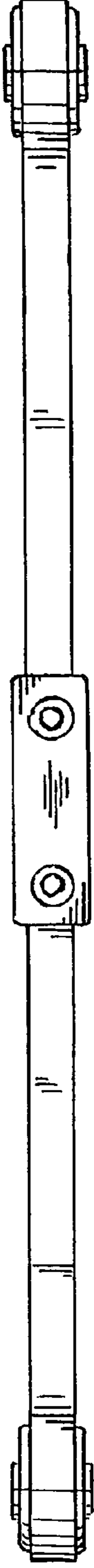

FIG. 5

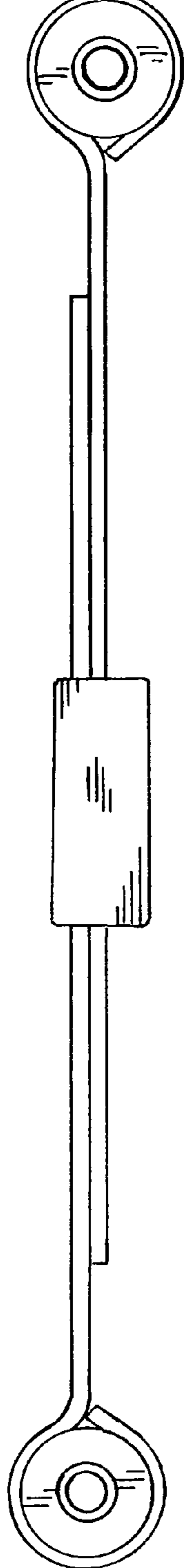

FIG. 6

