



US00D712341S

(12) **United States Design Patent**
Lefgren et al.

(10) **Patent No.:** **US D712,341 S**

(45) **Date of Patent:** **** Sep. 2, 2014**

(54) **RUDDER FOR ELECTRIC TROLLING MOTOR**

(71) Applicants: **James Lefgren**, Richmond, UT (US);
Travis Hendrickson, Bear River City, UT (US)

(72) Inventors: **James Lefgren**, Richmond, UT (US);
Travis Hendrickson, Bear River City, UT (US)

(**) Term: **14 Years**

(21) Appl. No.: **29/463,374**

(22) Filed: **Oct. 31, 2013**

(51) **LOC (10) Cl.** **12-06**

(52) **U.S. Cl.**
USPC **D12/317**

(58) **Field of Classification Search**
USPC D12/300, 303, 317; 114/144 A, 144 C,
114/144 E, 144 R, 145 R, 150-153, 162-169;
440/51, 71, 61 S
See application file for complete search history.

(56) **References Cited**

U.S. PATENT DOCUMENTS

638,542 A * 12/1899 Atwood 114/165
1,302,956 A 5/1919 Owen
1,858,046 A * 5/1932 Hill 114/162

1,936,409 A * 11/1933 Scholz 114/162
1,966,029 A * 7/1934 Fahrney 440/51
3,516,378 A * 6/1970 Linsley 114/165
3,687,101 A * 8/1972 Linsley 440/51
3,939,792 A * 2/1976 Wasenius 114/162
3,991,700 A 11/1976 Cleary et al.
4,634,388 A 1/1987 Covell
D313,003 S 12/1990 Cain
5,902,157 A 5/1999 Boris
D509,177 S * 9/2005 Clarke et al. D12/317
8,171,870 B2 * 5/2012 Gasper 114/144 R
2005/0235895 A1 * 10/2005 Furlong 114/162

* cited by examiner

Primary Examiner — Cynthia M Chin

(57) **CLAIM**

We claim the ornamental design for a “rudder for electric trolling motor,” as shown and described.

DESCRIPTION

FIG. 1 is a right side perspective view of our new rudder design.

FIG. 2 is a left side perspective view thereof.

FIG. 3 is a right side perspective exploded view; and, FIG. 4 is a reduced right side view of the rudder shown attached to a trolling motor. The trolling motor shown with broken lines, illustrates an exemplary environment in which the rudder resides and forms no part of the claimed design.

1 Claim, 4 Drawing Sheets

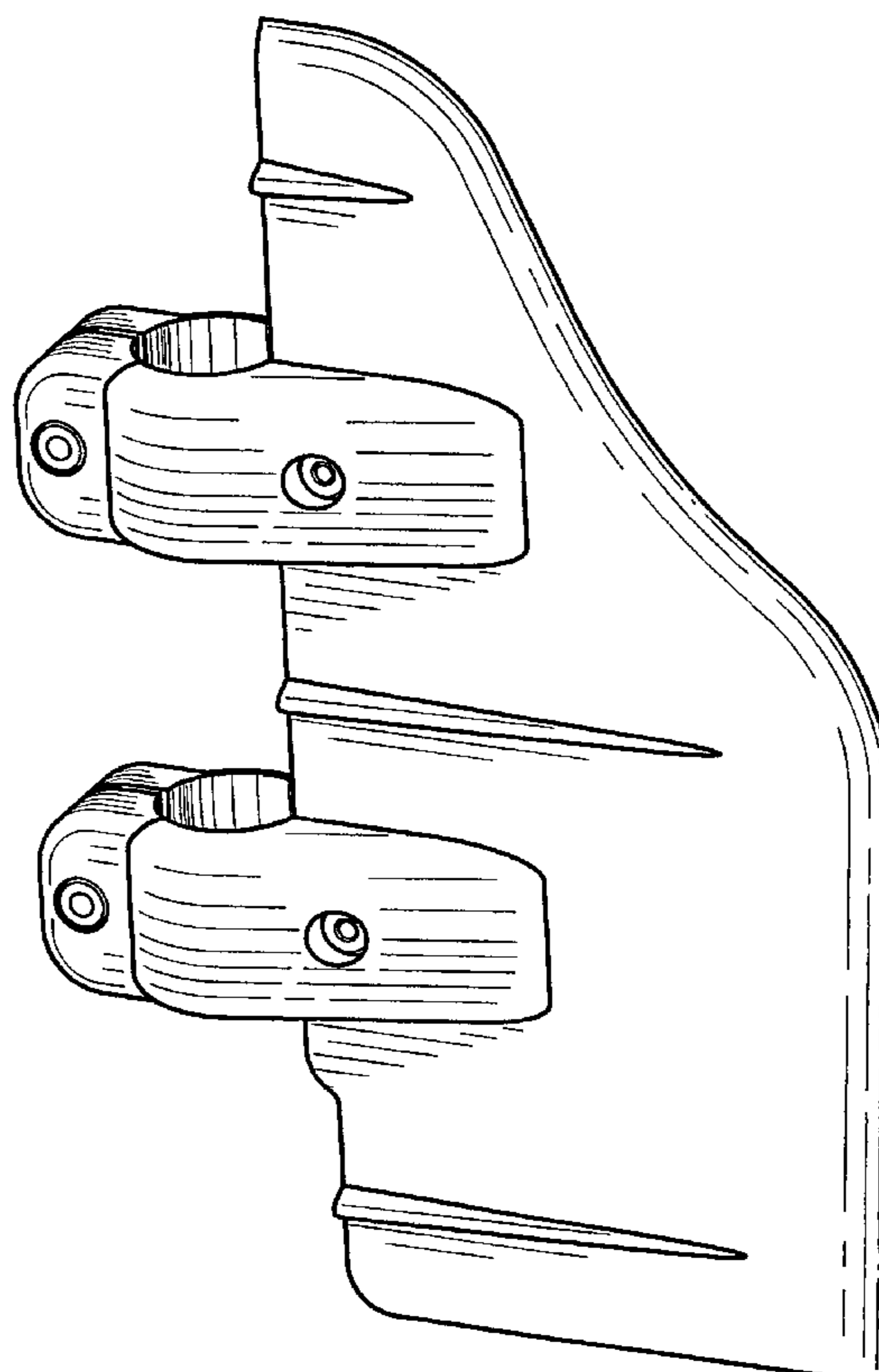
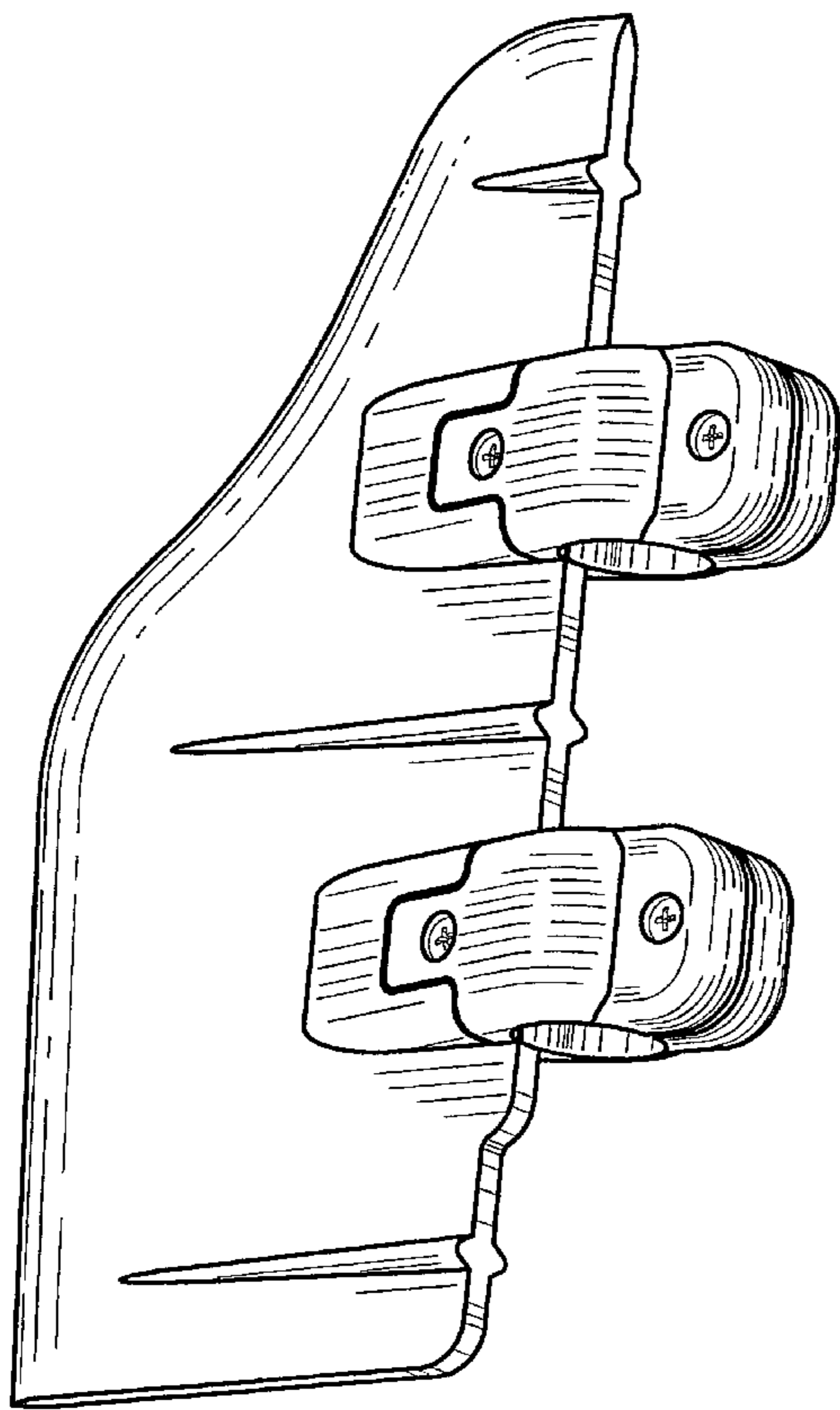

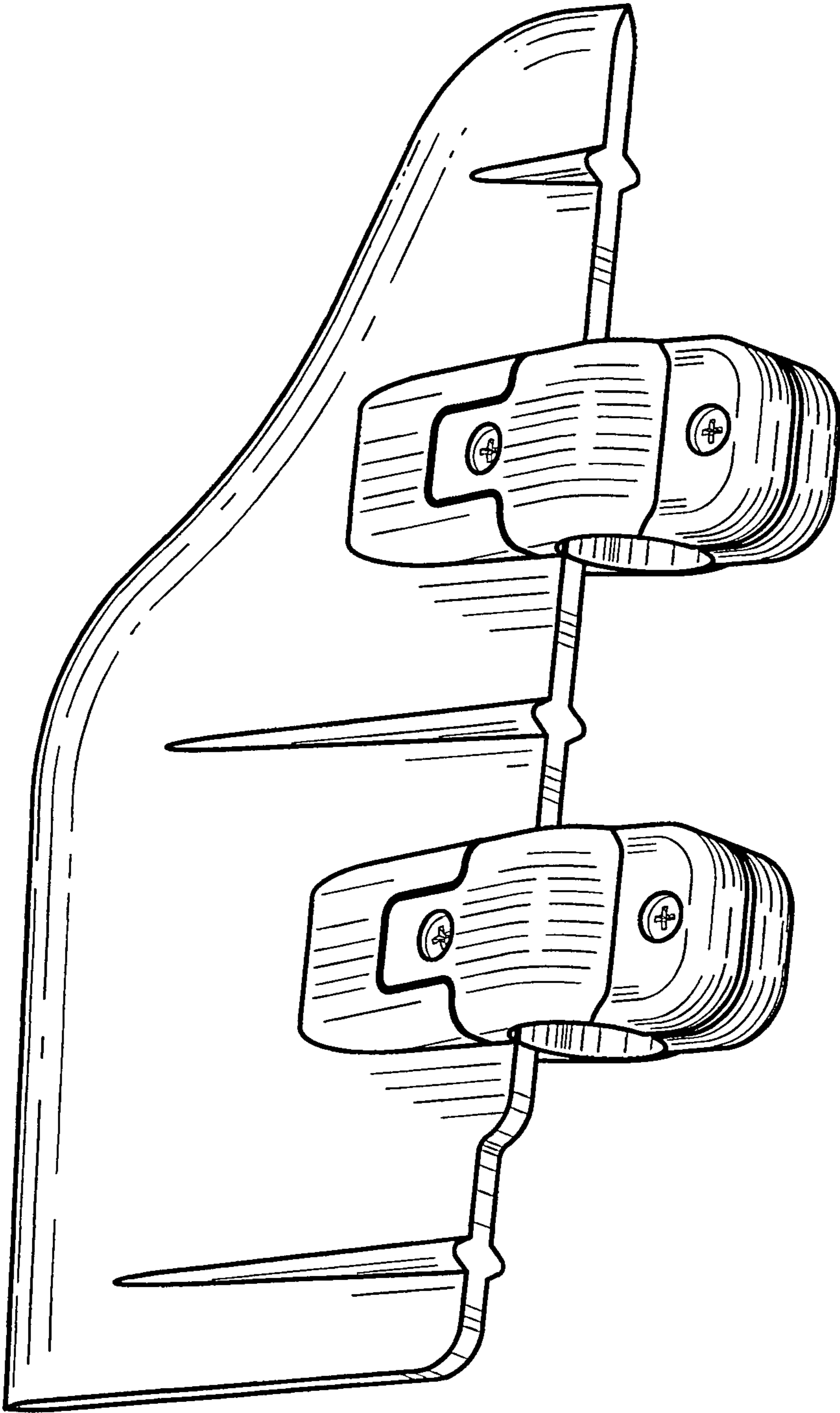

Figure 1

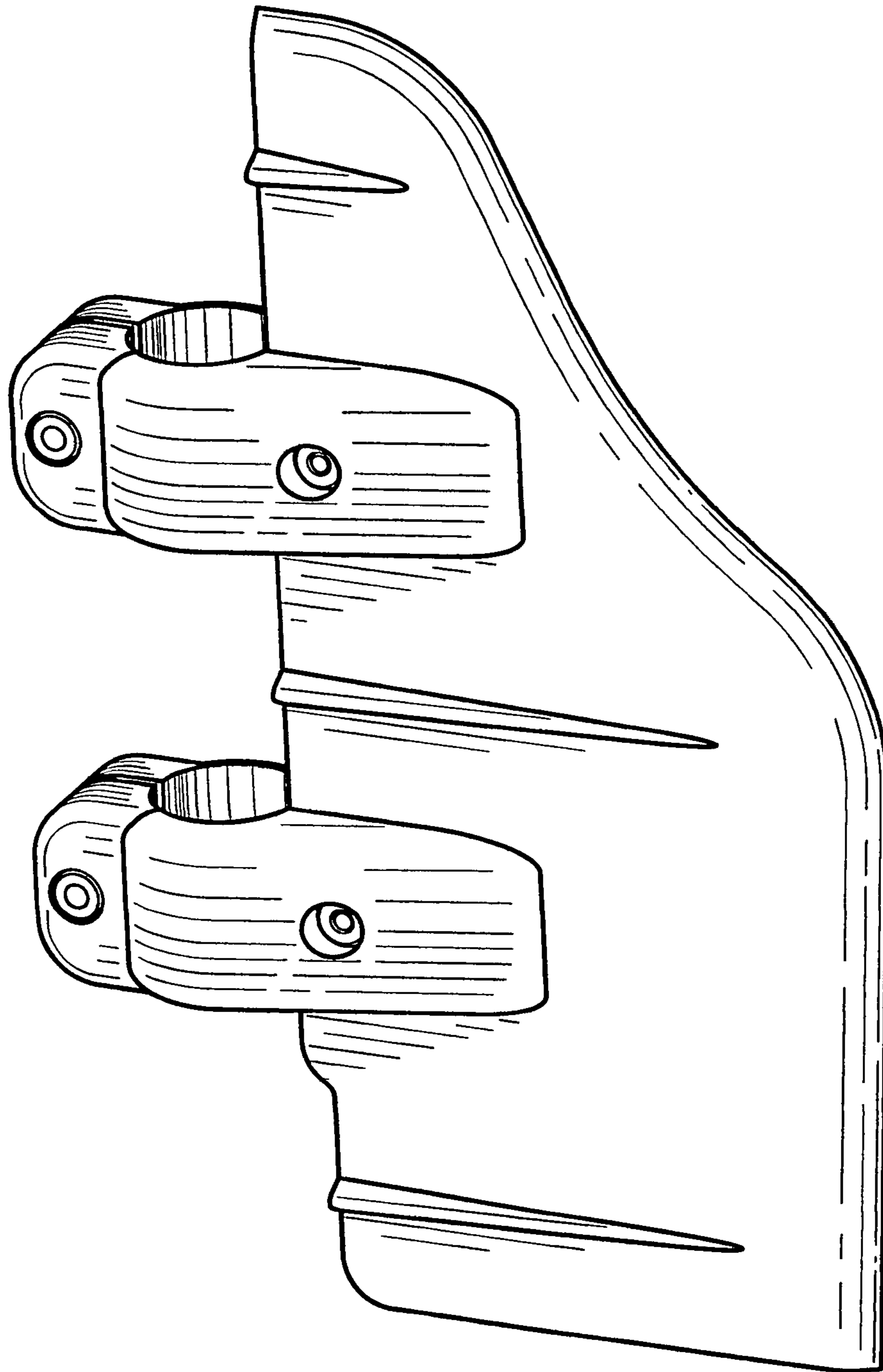

Figure 2

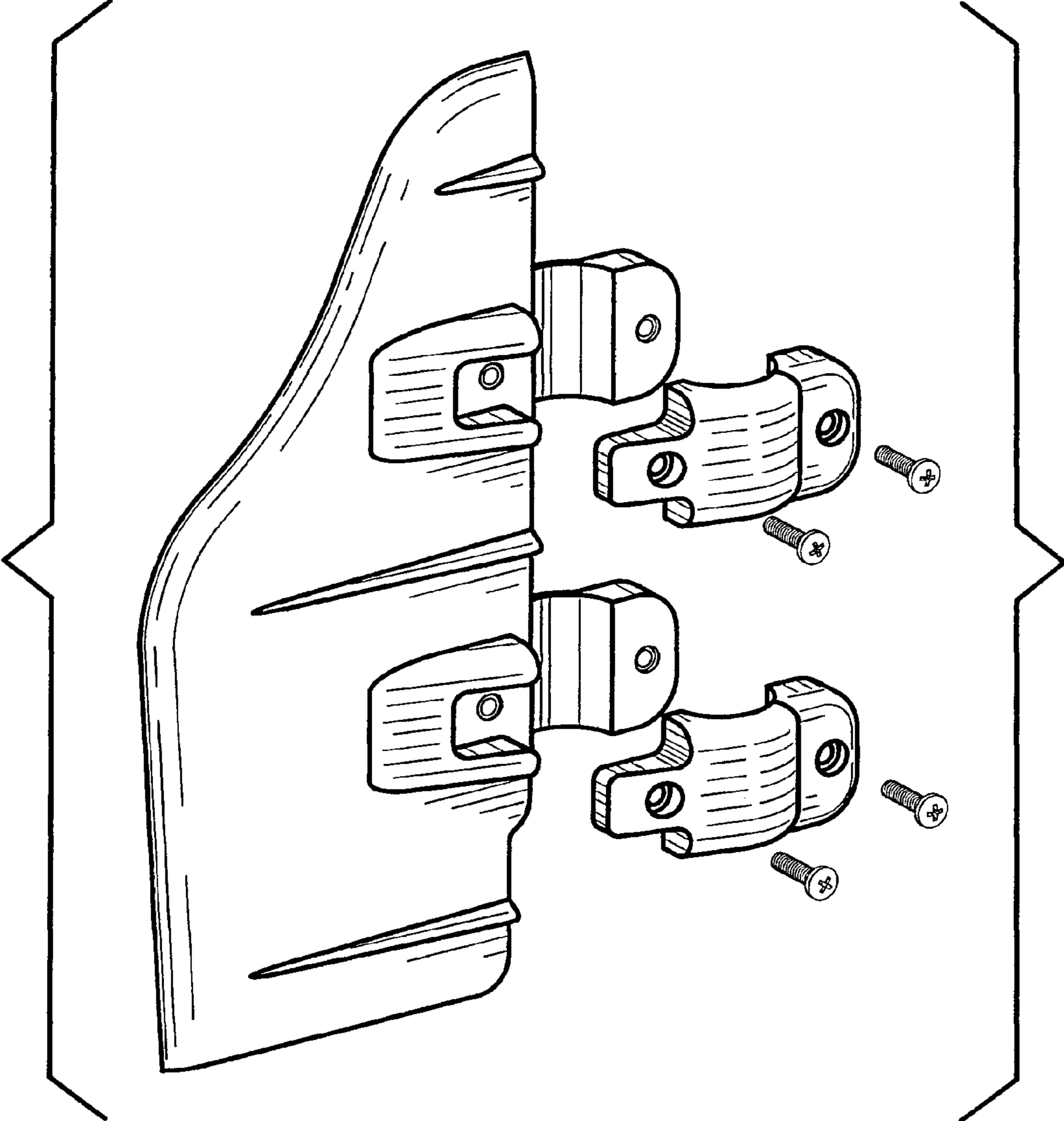

Figure 3

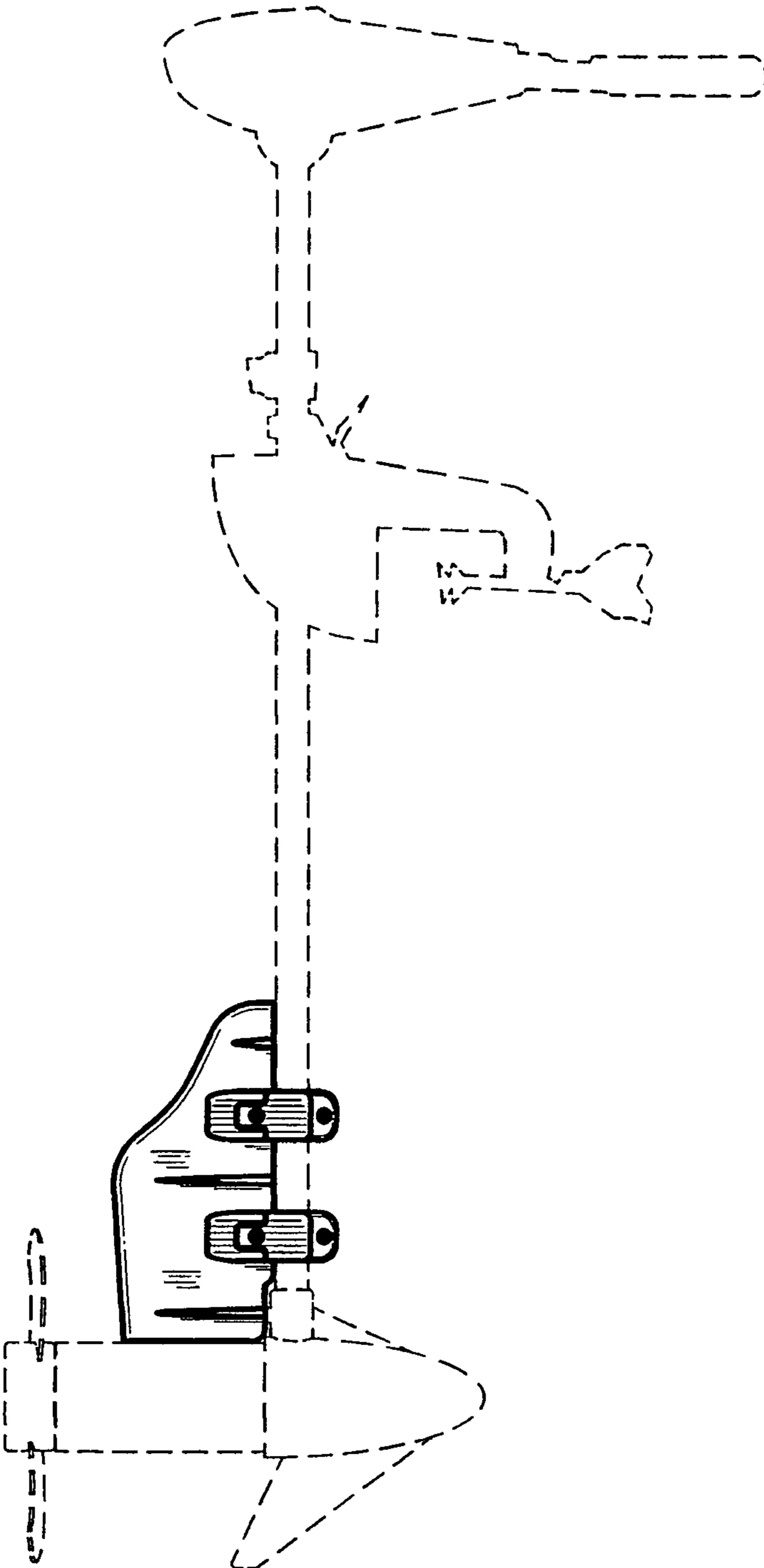

Figure 4