



US00D712312S

(12) **United States Design Patent**  
**Nakayama**

(10) **Patent No.:** **US D712,312 S**

(45) **Date of Patent:** **\*\* Sep. 2, 2014**

(54) **AUTOMOBILE, TOY REPLICA AND/OR  
OTHER REPLICAS**

(71) Applicant: **Honda Motor Co., Ltd.**, Tokyo (JP)

(72) Inventor: **Ryo Nakayama**, Wako (JP)

(73) Assignee: **Honda Motor Co., Ltd.**, Tokyo (JP)

(\*\*) Term: **14 Years**

(21) Appl. No.: **29/432,867**

(22) Filed: **Sep. 21, 2012**

(30) **Foreign Application Priority Data**

Mar. 30, 2012 (JP) ..... 2012-007529

(51) **LOC (10) Cl.** ..... **12-08**

(52) **U.S. Cl.**  
USPC ..... **D12/91**

(58) **Field of Classification Search**  
USPC ..... D12/169, 196, 171, 163, 216, 90-92,  
D12/86; 296/180.1, 180.2; 293/102, 113,  
293/115, 117, 120; 180/68.1, 68.6  
See application file for complete search history.

(56) **References Cited**

**U.S. PATENT DOCUMENTS**

D468,237 S *	1/2003	Murkett	.....	D12/91
D499,356 S *	12/2004	Minami et al.	.....	D12/91
D539,710 S *	4/2007	Kouyama	.....	D12/169
D551,125 S *	9/2007	Uchino et al.	.....	D12/92
D557,177 S *	12/2007	Endo et al.	.....	D12/91
D574,751 S *	8/2008	Fukui et al.	.....	D12/91
D599,705 S *	9/2009	Konaka et al.	.....	D12/91
D619,501 S *	7/2010	Mueller	.....	D12/91
D642,501 S *	8/2011	Yokoi et al.	.....	D12/164
D643,788 S *	8/2011	Sowa et al.	.....	D12/164
D647,439 S *	10/2011	Nemoto et al.	.....	D12/169
D649,093 S *	11/2011	Yokoi et al.	.....	D12/164
D671,045 S *	11/2012	Fetherston et al.	.....	D12/164
D673,087 S *	12/2012	Hotta et al.	.....	D12/169

D681,528 S *	5/2013	Yamada et al.	.....	D12/196
D682,166 S *	5/2013	Minami	.....	D12/169
D691,936 S *	10/2013	Kawasaki et al.	.....	D12/196
D693,278 S *	11/2013	Morioka	.....	D12/169
2010/0026045 A1 *	2/2010	Thomas	.....	296/180.1

**OTHER PUBLICATIONS**

2013 Honda Fit, Oct. 1, 2013, [online], [site visited Jan. 6, 2014]. Available from Internet, <URL: <http://automobiles.honda.com/fit/>>.\*

Honda Civic Tourer, Aug. 13, 2013, [online], [site visited Jan. 6, 2014]. Available from Internet, <URL: [http://www.roadandtrack.com/go/news/new-cars/go-news-new-cars-honda-civic-tourer?click=main\\_sr](http://www.roadandtrack.com/go/news/new-cars/go-news-new-cars-honda-civic-tourer?click=main_sr)>.\*

\* cited by examiner

*Primary Examiner* — Eric Goodman

*Assistant Examiner* — Jennifer Watkins

(74) *Attorney, Agent, or Firm* — Plumsea Law Group, LLC

(57) **CLAIM**

The ornamental design for an automobile, toy replica and/or other replicas, as shown and described.

**DESCRIPTION**

FIG. 1 is a perspective view from the front left side of a first embodiment of an automobile, toy replica and/or other replicas.

FIG. 2 is a perspective view from the rear left side thereof.

FIG. 3 is a left side elevation view thereof.

FIG. 4 is a right side elevation view thereof.

FIG. 5 is a front elevation view thereof.

FIG. 6 is a rear elevation view thereof; and,

FIG. 7 is a top plan view thereof.

The portions of the article shown in broken lines are for the purpose of showing environmental structure only and form no part of the claimed design. The dot-dash lines show an unclaimed boundary which forms no part of the claimed design.

**1 Claim, 7 Drawing Sheets**

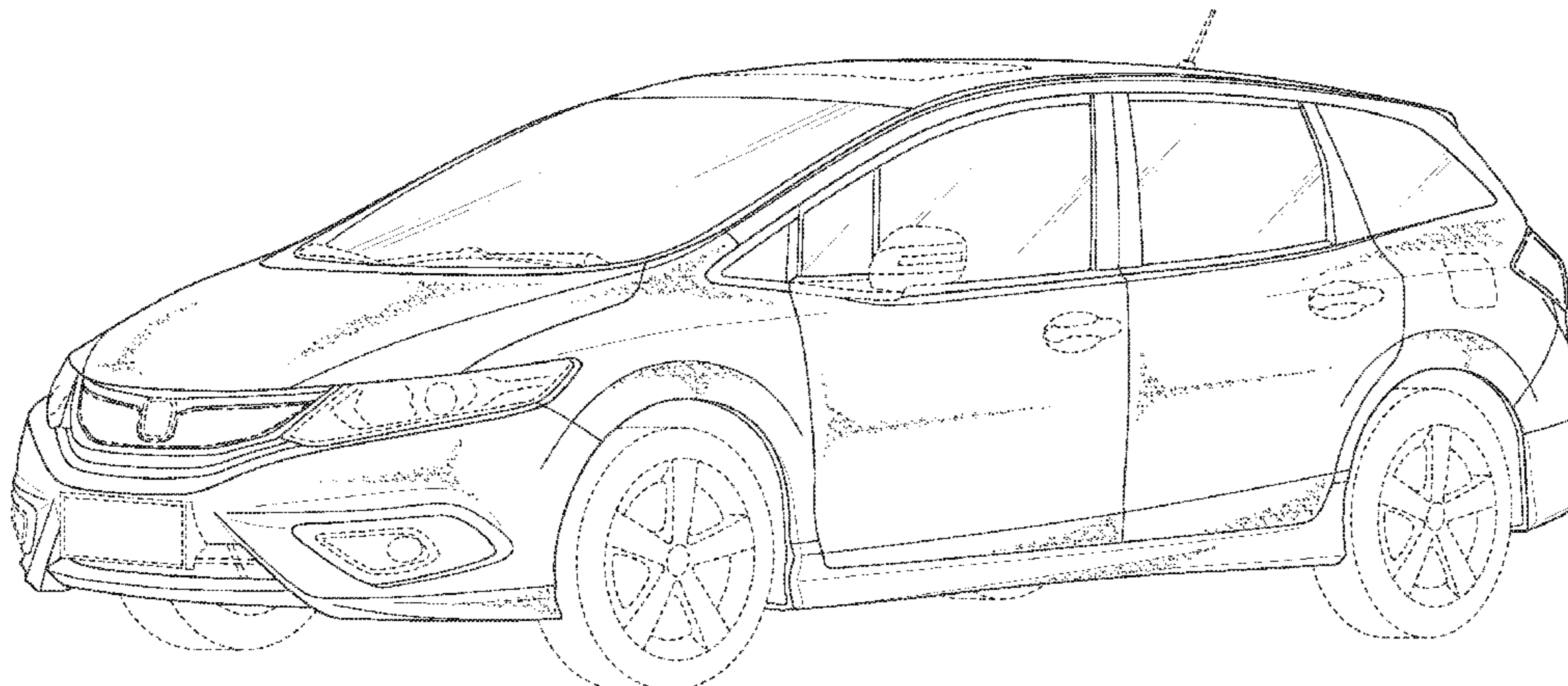

FIG. 1

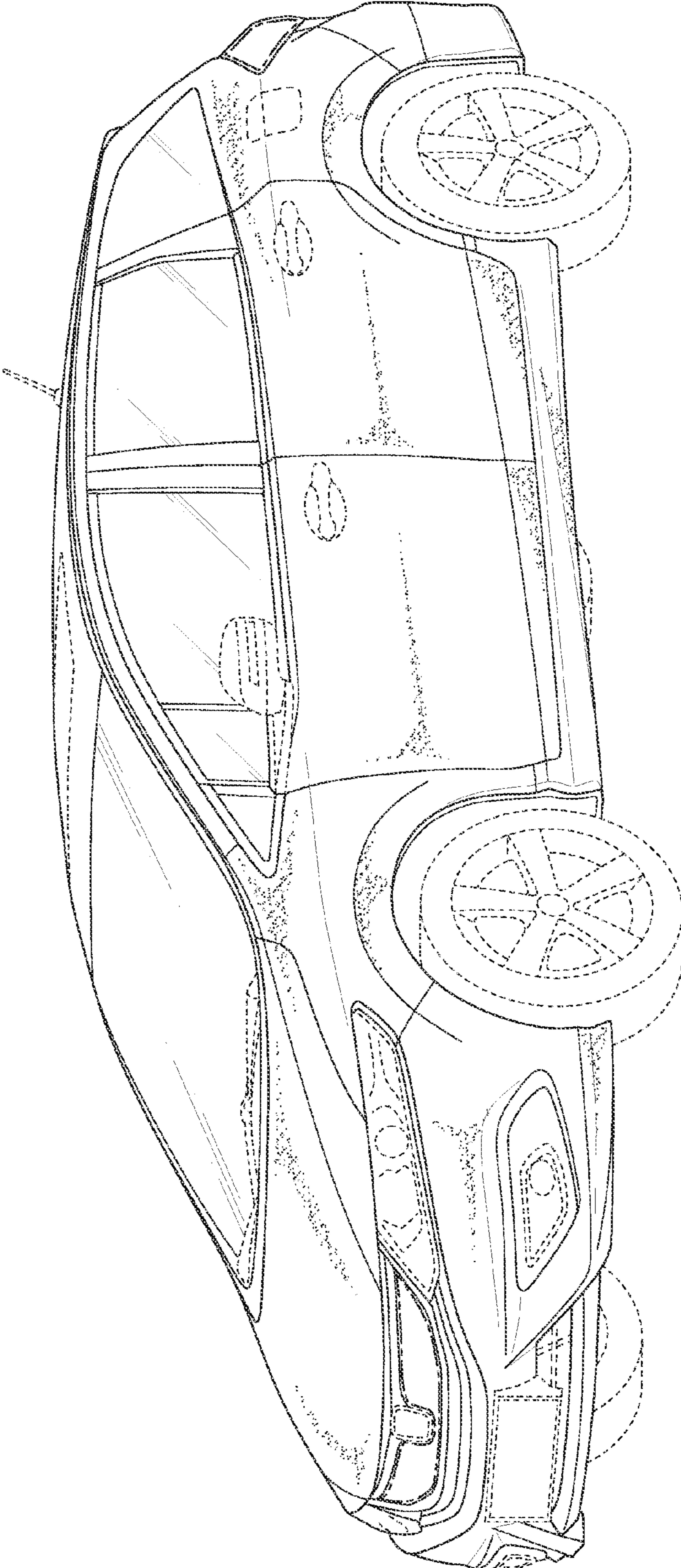

FIG. 2

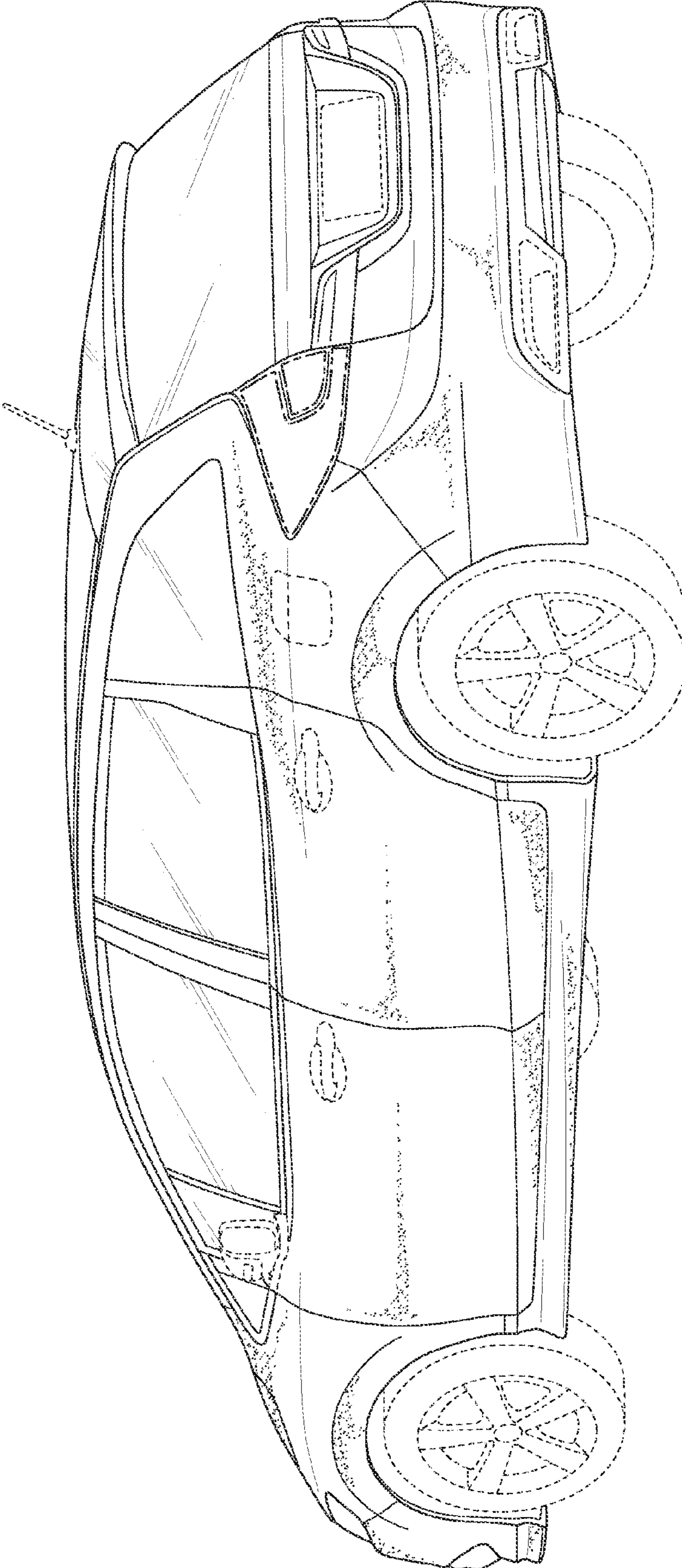

FIG. 3

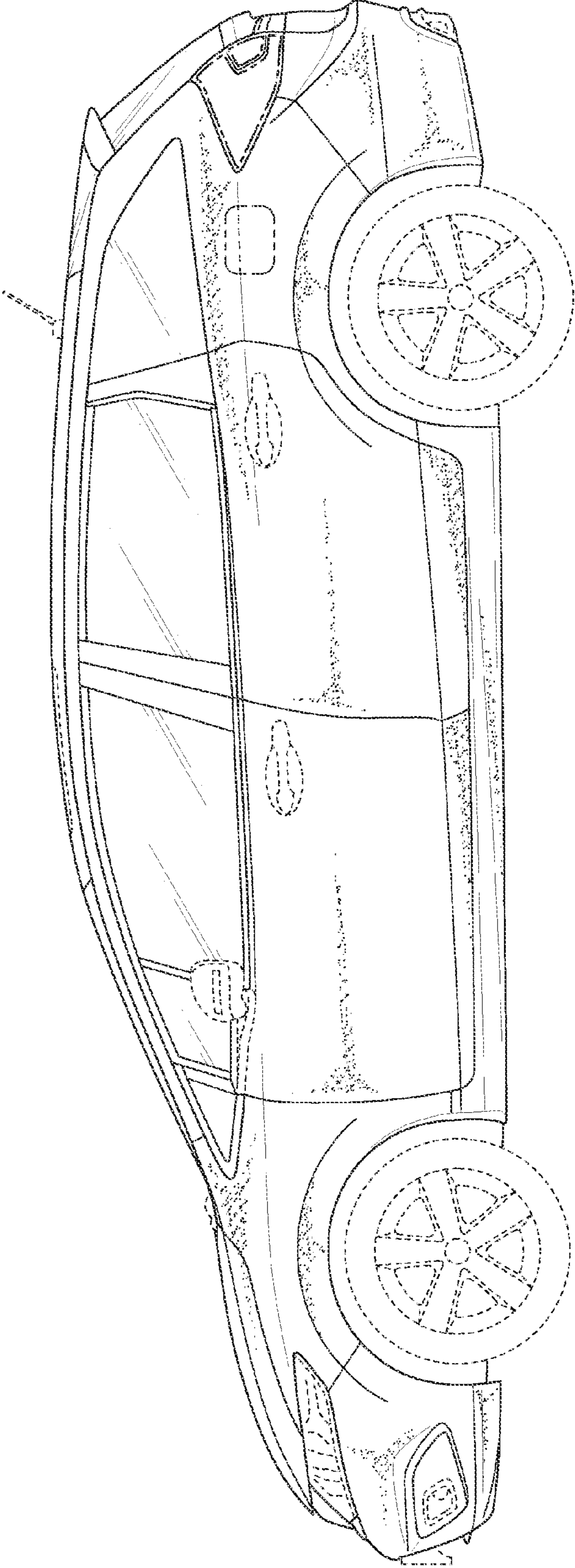

FIG. 4

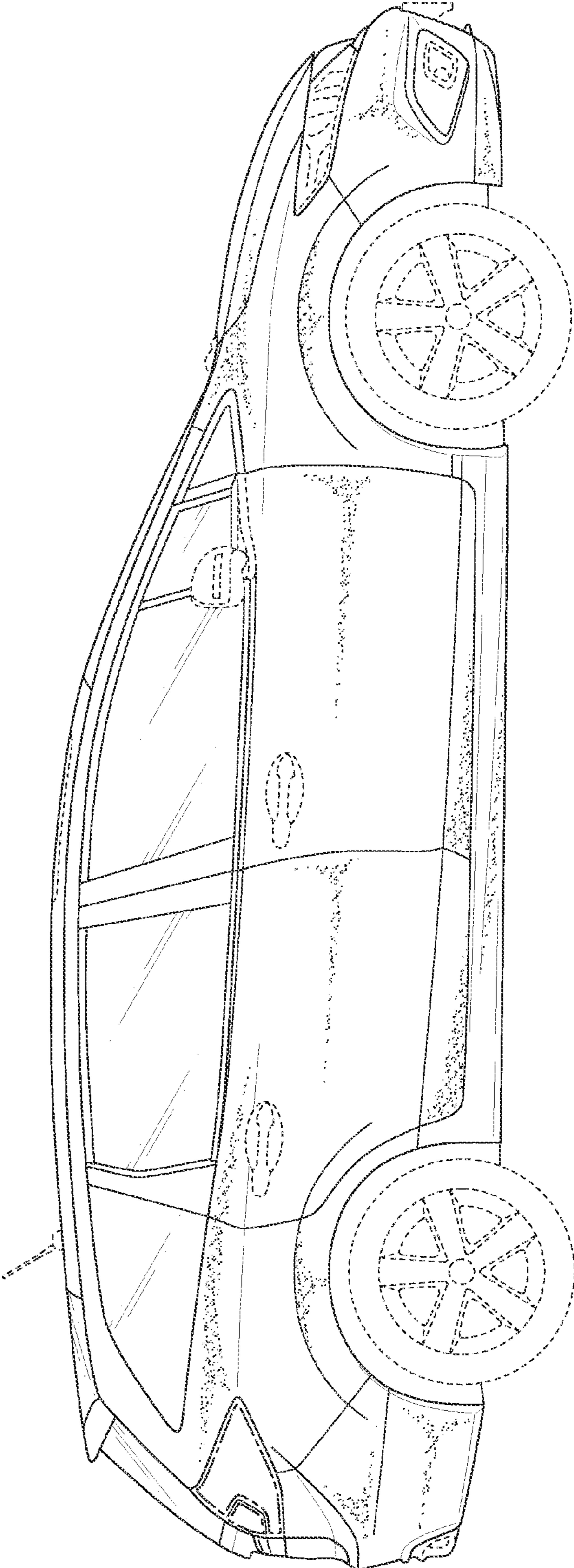

FIG. 5

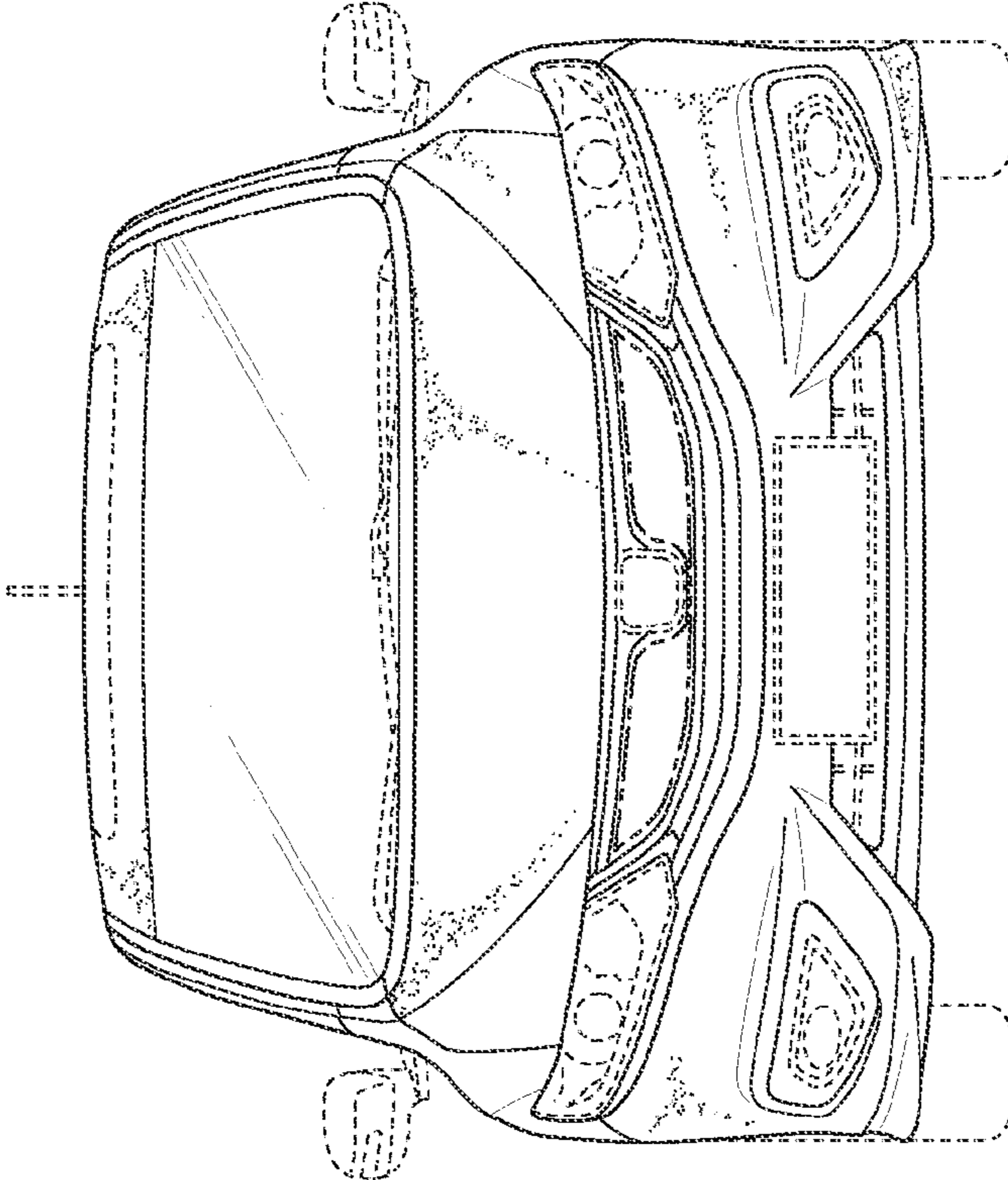

FIG. 6

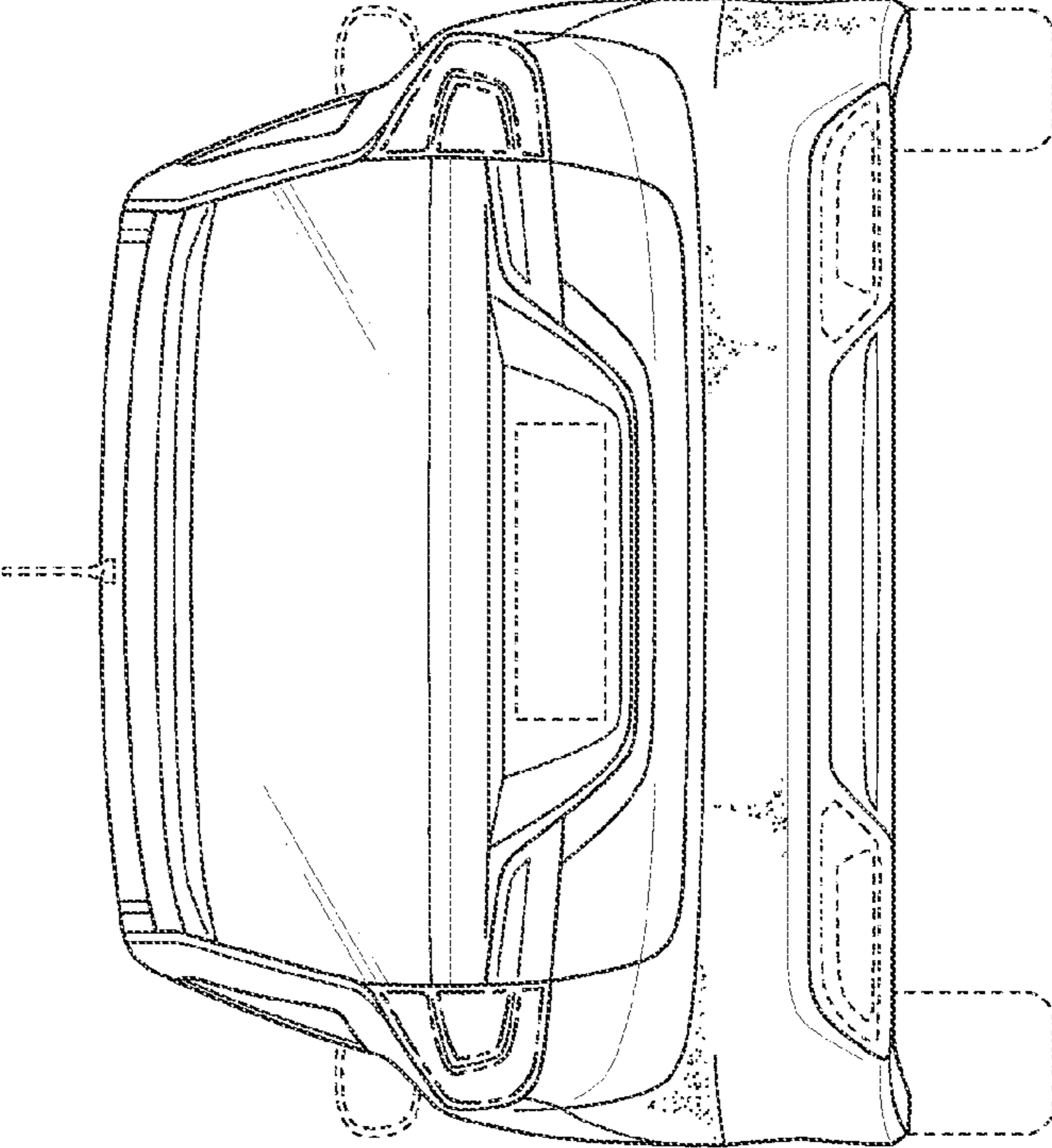

FIG. 7

