



US00D712310S

(12) **United States Design Patent**  
**Gundlach et al.**

(10) **Patent No.:** **US D712,310 S**

(45) **Date of Patent:** **\*\* Sep. 2, 2014**

(54) **TOP HOOK AIRCRAFT**

(75) Inventors: **John Gundlach**, Manassas, VA (US);  
**Francesco Giannini**, Vienna, VA (US);  
**Cayce Boone**, Manassas, VA (US)

(73) Assignee: **Aurora Flight Sciences Corporation**,  
Manassas, VA (US)

(\*\*) Term: **14 Years**

(21) Appl. No.: **29/418,353**

(22) Filed: **Apr. 16, 2012**

(51) **LOC (10) Cl.** ..... **12-07**

(52) **U.S. Cl.**  
USPC ..... **D12/16.1; D12/319**

(58) **Field of Classification Search**  
USPC ..... D12/16.1, 319, 325, 326, 327, 328, 329,  
D12/331-334, 337, 338, 339-345;  
D21/430, 436, 442, 447, 448, 450, 451,  
D21/452, 453; 244/2, 3, 5, 6, 7 A, 7 R, 7 C,  
244/12.1-12.4, 63, 135 A, 78.1, 137.1, 170;  
343/707; 446/34, 36, 37, 56, 57,  
446/61-68, 230-233; 280/1.12  
See application file for complete search history.

(56) **References Cited**

**U.S. PATENT DOCUMENTS**

1,869,506	A *	8/1932	Richardson	.....	244/2
2,385,392	A *	9/1945	Van Dusen	.....	244/3
2,440,737	A *	5/1948	Cawein	.....	343/707
2,520,620	A *	8/1950	Ashwood	.....	244/3
3,520,502	A *	7/1970	Smethers, Jr.	.....	244/137.1
3,599,907	A *	8/1971	Ransom et al.	.....	244/135 A
3,747,873	A *	7/1973	Layer et al.	.....	244/3
4,014,481	A *	3/1977	Daikeler et al.	.....	244/3
D320,189	S *	9/1991	Thompson et al.	.....	D12/326
5,103,712	A *	4/1992	Minovitch	.....	89/1.11
5,188,313	A *	2/1993	Piasecki	.....	244/3
5,906,336	A *	5/1999	Eckstein	.....	244/135 A
D439,876	S *	4/2001	Simonov et al.	.....	D12/342

6,324,295	B1 *	11/2001	Valery et al.	.....	382/100
D471,853	S *	3/2003	Lucchesini	.....	D12/319
6,874,729	B1 *	4/2005	McDonnell	.....	244/63

(Continued)

*Primary Examiner* — Caron D. Veynar

*Assistant Examiner* — Martie K Holtje

(74) *Attorney, Agent, or Firm* — Michael Stanley Tomsa;  
Katten Muchin Rosenman LLP

(57) **CLAIM**

The ornamental design for the top hook aircraft, as shown and described.

**DESCRIPTION**

FIG. 1 is a front perspective view of an embodiment of a top hook aircraft with a top hook in a fully extended position in accordance with the present invention;

FIG. 2 is a front view of the top hook aircraft in accordance with the embodiment shown in FIG. 1 with the top hook in the fully extended position;

FIG. 3 is a top view of the top hook aircraft in accordance with the embodiment shown in FIG. 1 with the top hook in a fully retracted position;

FIG. 4 is a right side view of the top hook aircraft in accordance with the embodiment shown in FIG. 1 with the top hook in the fully extended position;

FIG. 5 is a right side view of the top hook aircraft in accordance with the embodiment shown in FIG. 1 with the top hook in the fully retracted position; and,

FIG. 6 is a rear view of the top hook aircraft in accordance with the embodiment shown in FIG. 1 with the top hook in the fully extended position.

The left side view and the bottom view of the top hook aircraft, which are not shown, form no art of the claimed design. Further, the elements depicted by broken lines in FIGS. 1, 2, 4, 5, and 6 are provided for the purpose of illustrating portions of the top hook aircraft that form no part of the claimed design.

**1 Claim, 6 Drawing Sheets**

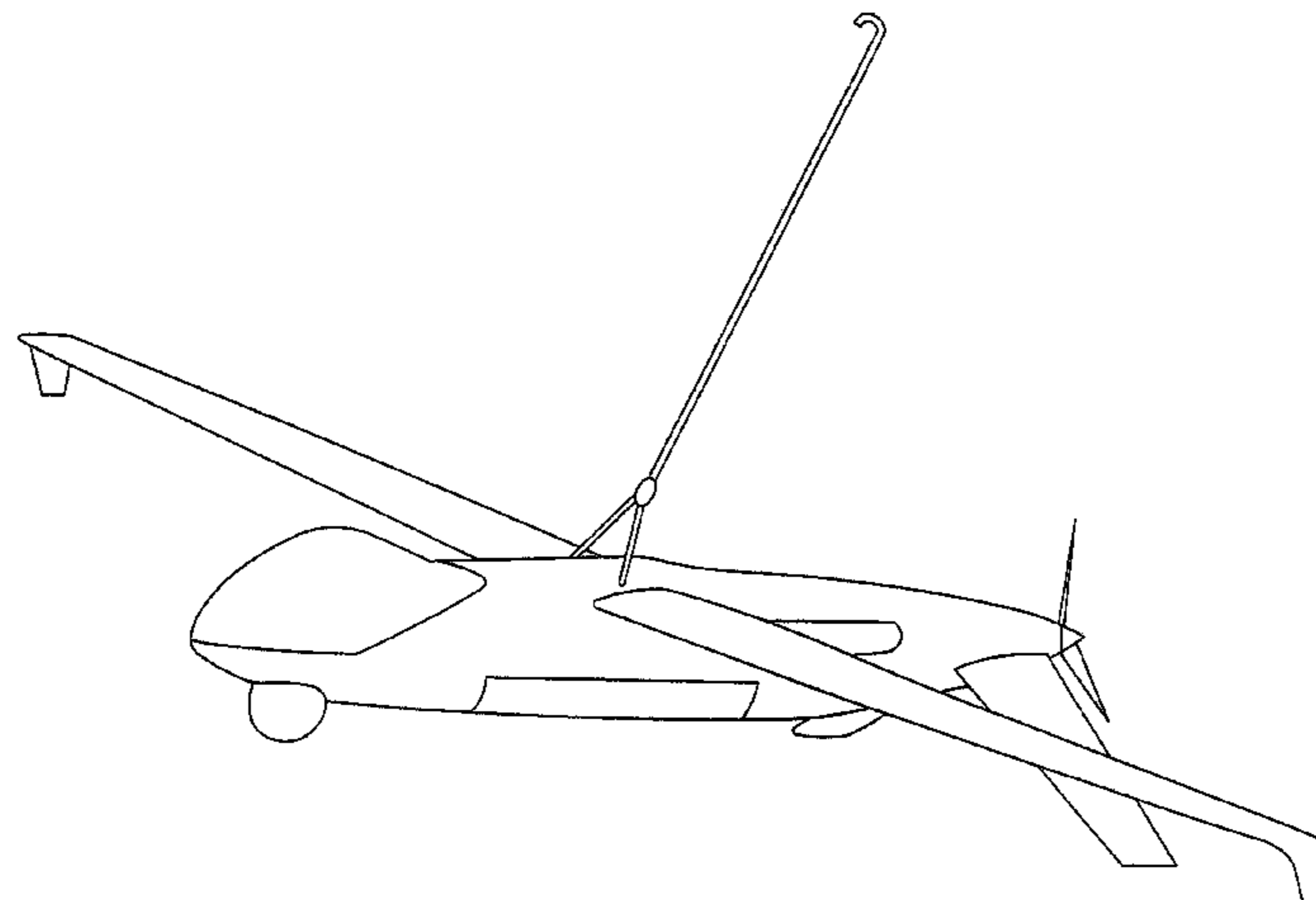

# US D712,310 S

Page 2

---

(56)

## References Cited

### U.S. PATENT DOCUMENTS

7,637,458 B2 *	12/2009	Near et al.	244/78.1
2002/0190162 A1 *	12/2002	McDonnell	244/170
2011/0024548 A1 *	2/2011	Kuroda et al.	244/3
7,152,828 B1 *	12/2006	Garcia et al.	244/135 A

\* cited by examiner

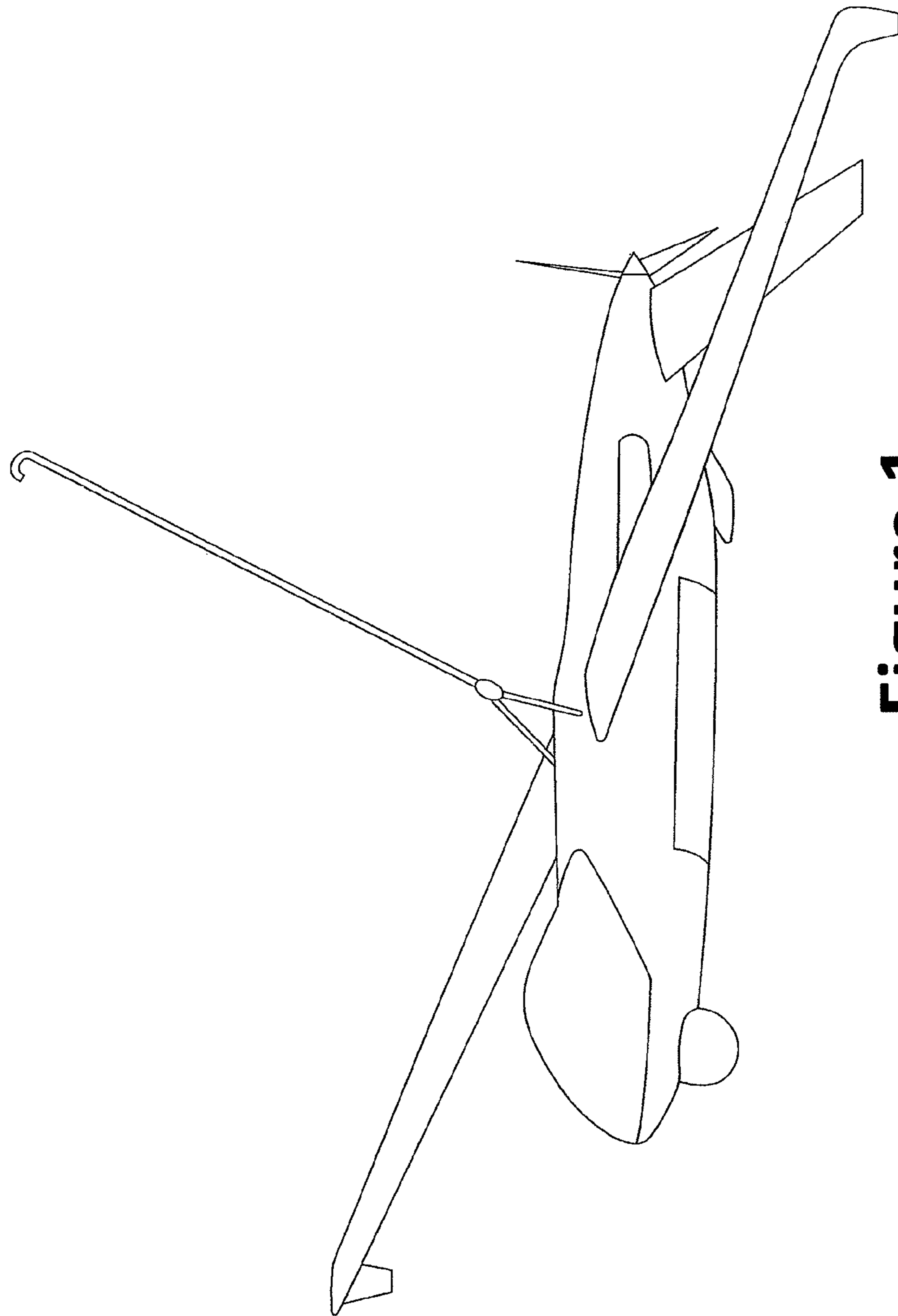

Figure 1

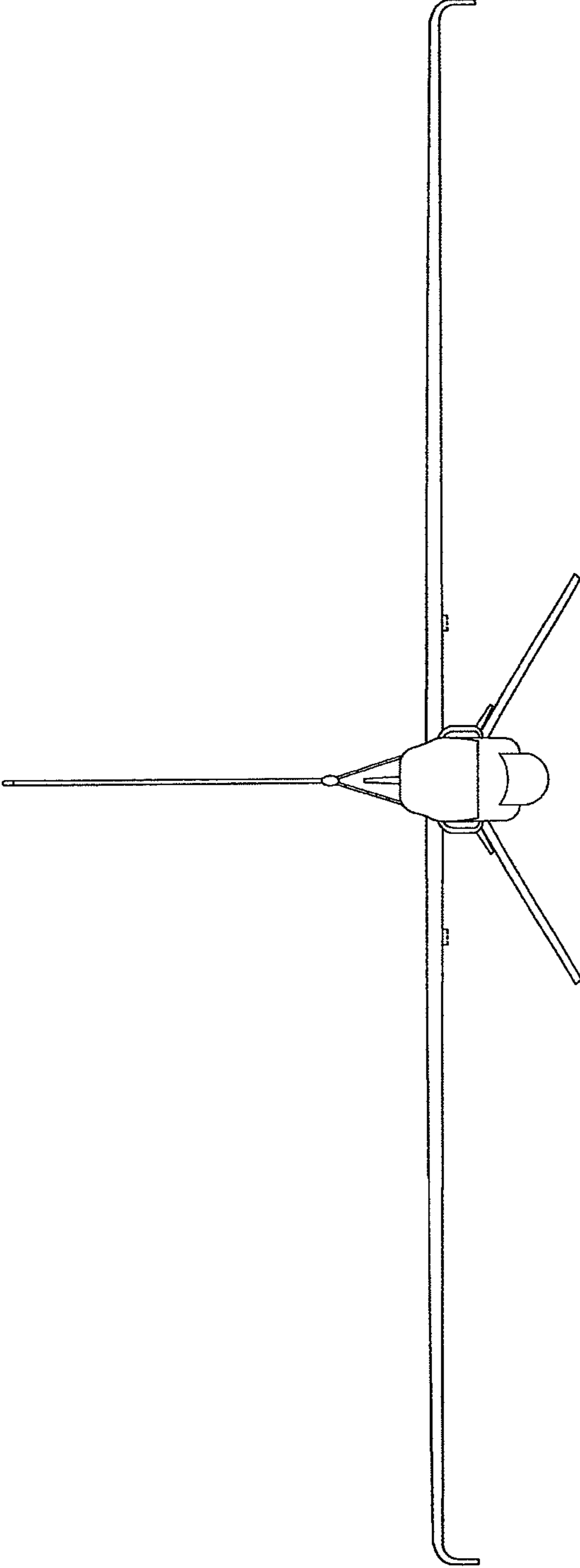

Figure 2

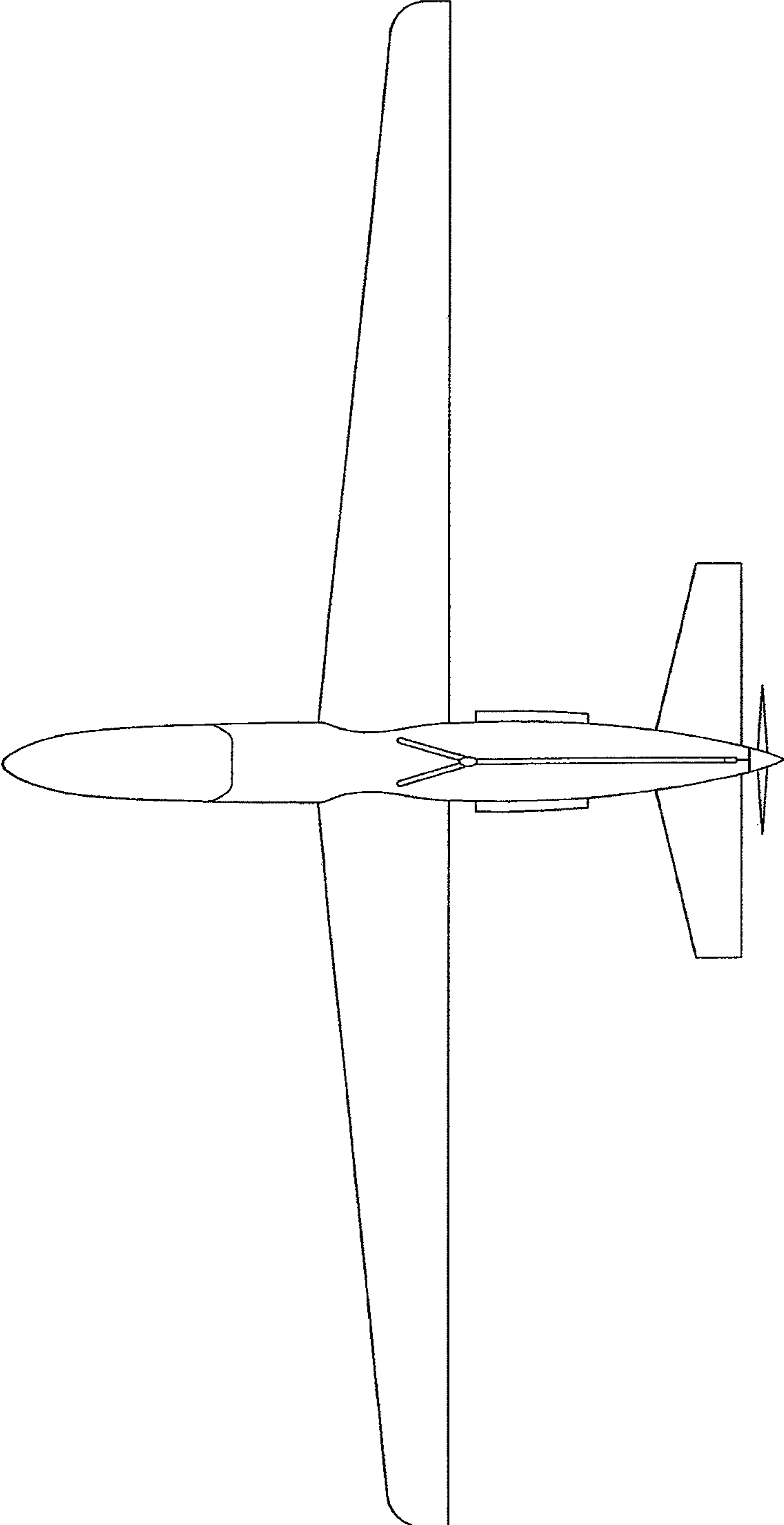

Figure 3

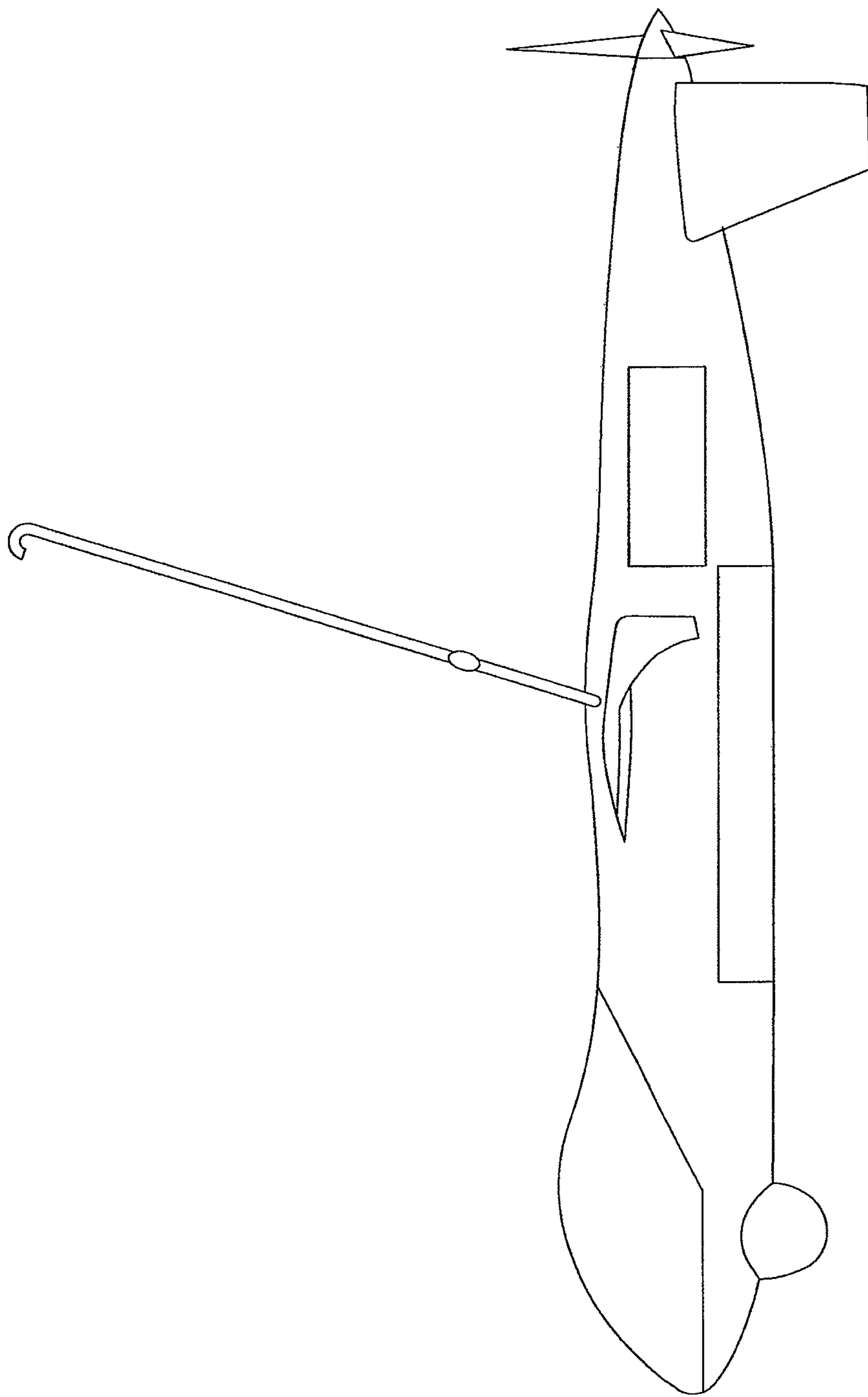

Figure 4

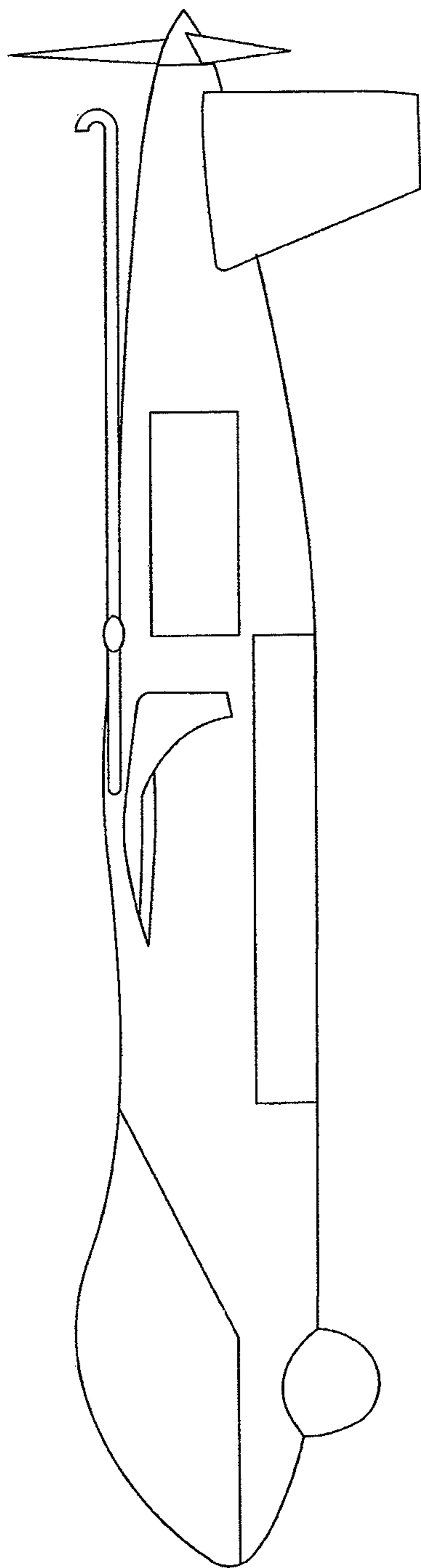

Figure 5

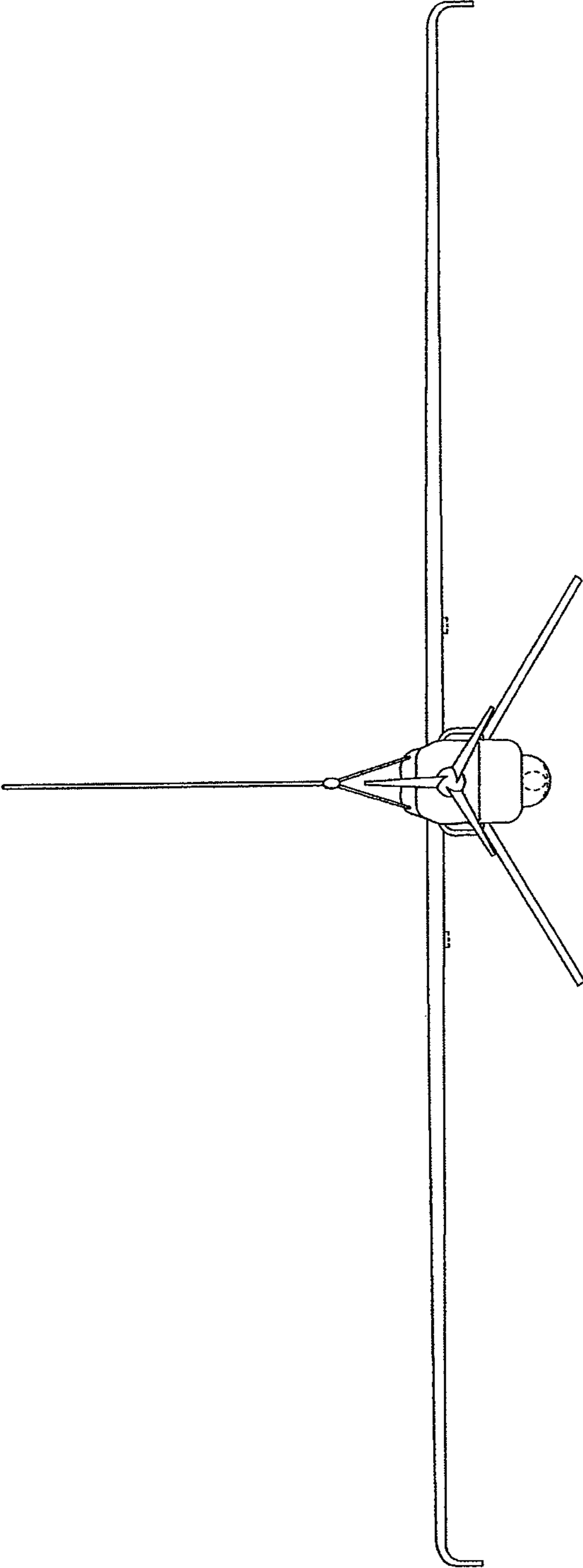

Figure 6