



US00D712290S

(12) **United States Design Patent**
Kagan et al.

(10) **Patent No.:** **US D712,290 S**
(45) **Date of Patent:** **** Sep. 2, 2014**

- (54) **ELECTRONIC METER**
- (71) Applicant: **Electro Industries/Gauge Tech,**
Westbury, NY (US)
- (72) Inventors: **Erran Kagan,** Great Neck, NY (US);
Tibor Banhegyesi, Bladwin, NY (US);
Avi Cohen, Great Neck, NY (US)
- (73) Assignee: **Electro Industries/Gauge Tech,**
Westbury, NY (US)
- (**) Term: **14 Years**
- (21) Appl. No.: **29/477,065**
- (22) Filed: **Dec. 19, 2013**

Related U.S. Application Data

- (63) Continuation-in-part of application No. 29/449,582,
filed on Mar. 15, 2013, which is a continuation of
application No. 13/834,737, filed on Mar. 15, 2013,
which is a continuation-in-part of application No.
12/628,636, filed on Dec. 1, 2009.
- (51) **LOC (10) Cl.** **10-04**
- (52) **U.S. Cl.**
USPC **D10/100; D10/103**
- (58) **Field of Classification Search**
USPC **D10/99, 100, 103; 324/74, 142;**
340/870.02, 870.05; 361/736, 668;
702/61
See application file for complete search history.

References Cited

U.S. PATENT DOCUMENTS

D56,045 S	8/1920	White
D76,149 S	2/1924	Olsen
1,705,301 A	3/1929	Miller
D187,740 S	4/1960	Littlejohn
D199,808 S	12/1964	Gazzam, III
D201,100 S	5/1965	Little et al.
D241,006 S	8/1976	Wallace
D273,574 S	4/1984	Overs

D332,923 S	2/1993	Polydoris et al.
D343,786 S	2/1994	Hines et al.
D348,019 S	6/1994	Kocol et al.
D366,434 S	1/1996	Brown, III et al.
5,581,470 A	12/1996	Pawloski
D427,533 S	7/2000	Cowan et al.
D429,655 S	8/2000	Cowan et al.
D435,471 S	12/2000	Simbeck et al.
D439,535 S	3/2001	Cowan et al.
D443,541 S	6/2001	Hancock et al.
D455,066 S	4/2002	Kolinen
D458,863 S	6/2002	Harding et al.
D459,259 S	6/2002	Harding et al.
6,476,595 B1	11/2002	Heuell et al.
6,476,729 B1	11/2002	Liu
6,745,138 B2	6/2004	Przydatek et al.
D525,893 S	8/2006	Kagan et al.
D526,920 S	8/2006	Kagan et al.
D545,181 S	6/2007	Kagan et al.
7,271,996 B2	9/2007	Kagan et al.
7,417,419 B2	8/2008	Tate
D615,895 S *	5/2010	Beattie D10/99
7,868,782 B2	1/2011	Ehrke et al.
D642,083 S	7/2011	Blanc et al.
D653,572 S	2/2012	Ohtani et al.
8,176,174 B2	5/2012	Kagan
D666,933 S	9/2012	Hoffman et al.
8,310,403 B2	11/2012	Nahar
8,325,057 B2	12/2012	Salter
D682,720 S	5/2013	Kagan et al.
D682,721 S	5/2013	Kagan et al.
8,587,949 B2	11/2013	Banhegyesi et al.
2002/0162014 A1	10/2002	Przydatek et al.
2004/0138786 A1	7/2004	Blackett et al.

OTHER PUBLICATIONS

- BE1-951 Multifunction Protection System, Basler Electric, Sep. 2012 pp. 1-12.
- Nexus 1262/1272 High Performance Utility Billing Meters With Communication & Advanced Power Quality, Electro Industries/Gaugetech, 062112 pp. 1-12.
- Jemstar High Accuracy Revenue Meter for Generation, Transmission, and Industrial Power Measurement, Ametek Power Instruments, 2012, pp. 1-2.
- Jemstar Retrofit for Generation, Transmission, and Industrial Power Measurement, Ametek Power Instruments, 2007, pp. 1-2.
- Mark-V EMS60 Intelligent Energy Meter, Advanced High-Accuracy Meter With Integrated Data Telemetry Solutions and Power Quality Monitoring, Transdata Energy Metering and Automation, 2010, pp. 1-2.

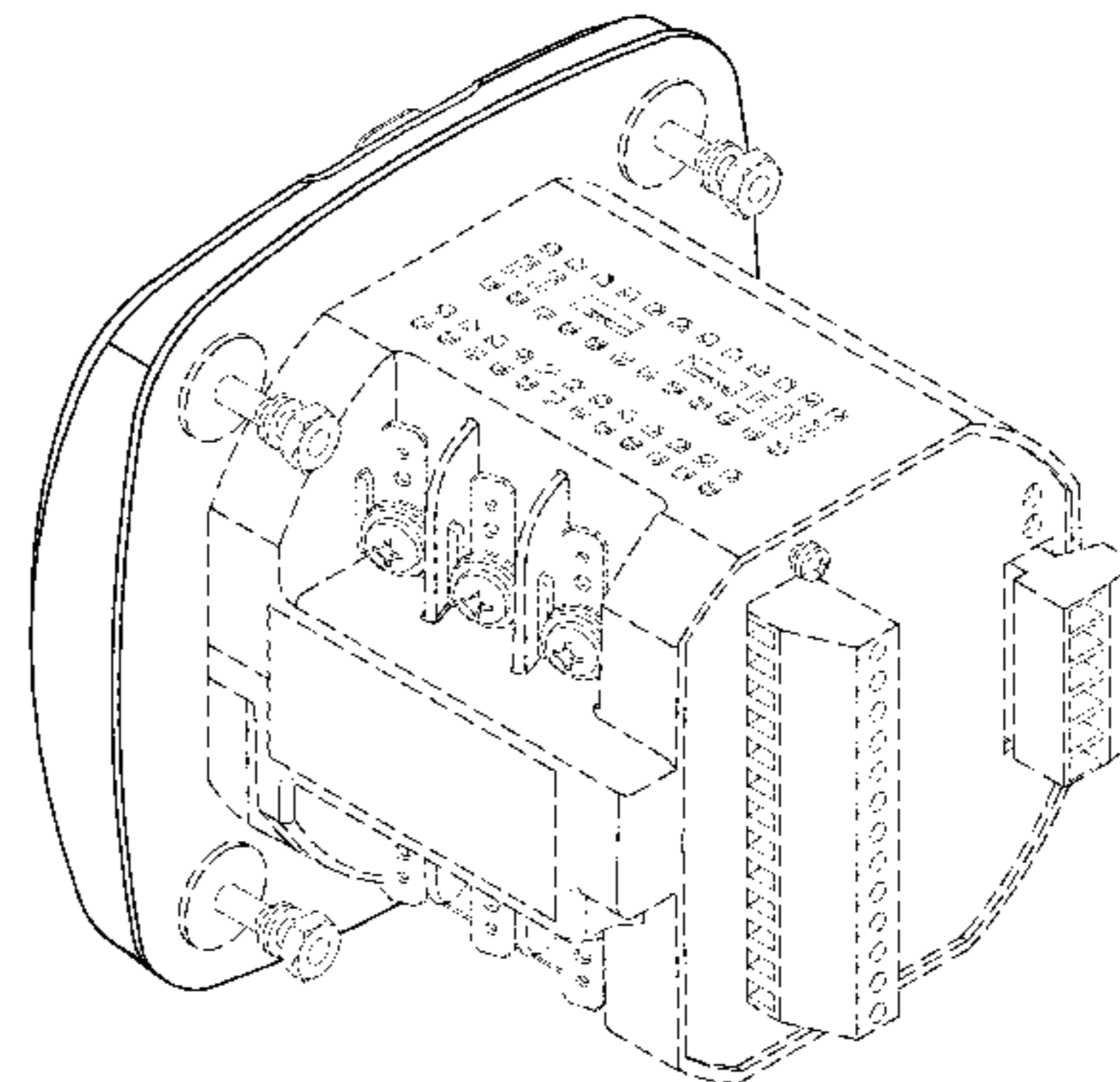
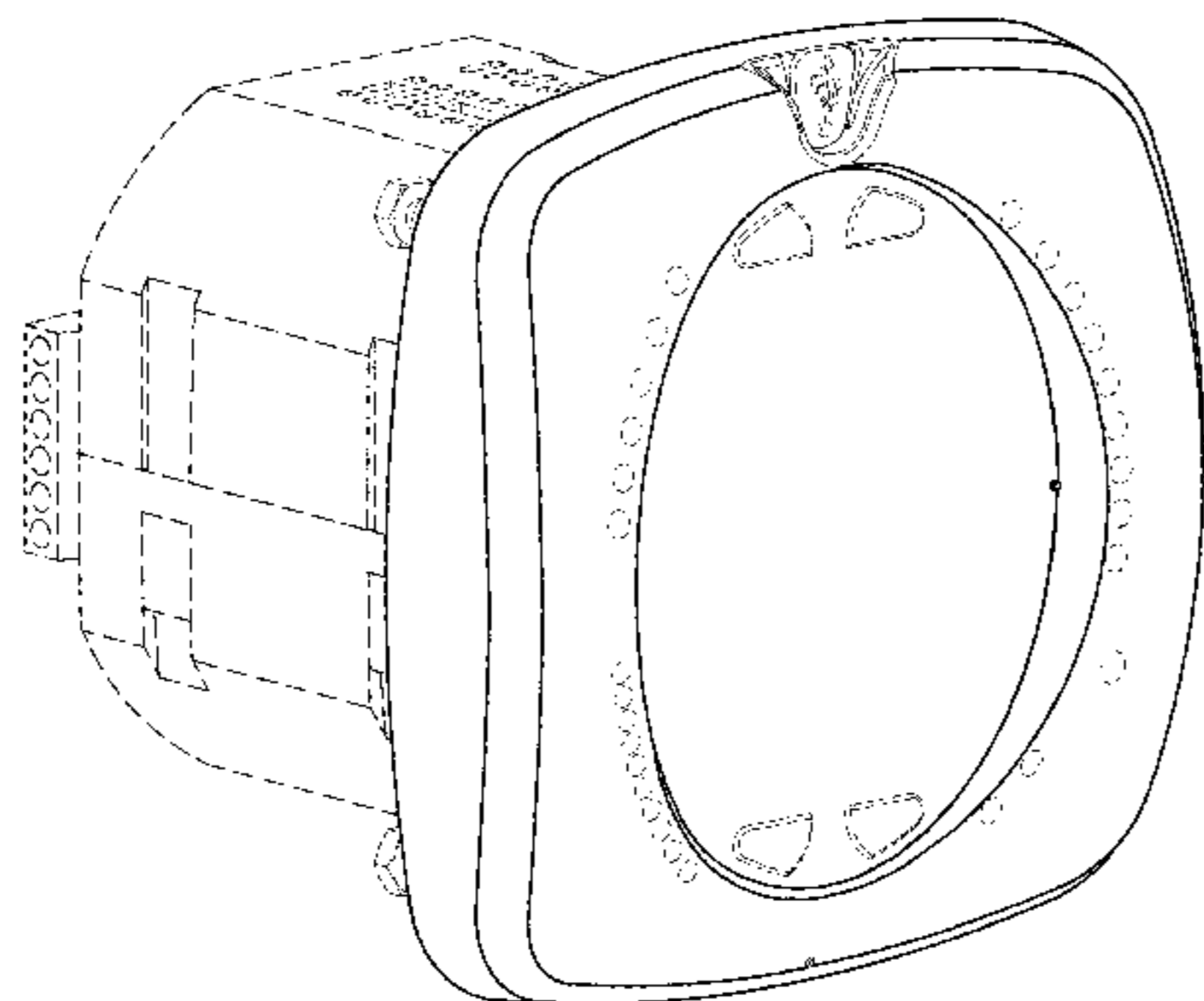

Nexus 1262/1272 Switchboard Meter Quick Start, Electro Industries-Gaugetech, 083112, pp. 1-4.
Powerlogic Ion8650, Schneider Electric, 2011, pp. 1-12.

* cited by examiner

Primary Examiner — Antoine D Davis
(74) *Attorney, Agent, or Firm* — Gerald E. Hespos; Michael J. Porco; Matthew T. Hespos

(57) **CLAIM**
The ornamental design of an electronic meter, as shown and described.

DESCRIPTION

FIG. 1 is a front, top, left perspective view of a electronic meter according to a first embodiment of our new design;
FIG. 2 is a rear, top, left perspective view thereof;
FIG. 3 is a front elevational view thereof;
FIG. 4 is a top plan view thereof;
FIG. 5 is a left side elevational view thereof;
FIG. 6 is a right side elevational view thereof;
FIG. 7 is a rear elevational view thereof;
FIG. 8 is a bottom plan view thereof;
FIG. 9 is a front, top, left perspective, exploded view of an electronic meter showing a port plug removed;
FIG. 10 is a front elevational view thereof showing a port plug removed;
FIG. 11 is a front, top, left perspective view of an electronic meter according to a second embodiment;
FIG. 12 is a front elevational view of FIG. 11;
FIG. 13 is a front, top, left perspective, exploded view of an electronic meter of FIG. 11 showing a port plug removed;
FIG. 14 is a front elevational view of FIG. 11 showing a port plug removed;
FIG. 15 is a front, top, left perspective view of an electronic meter according to a third embodiment;
FIG. 16 is a front elevational view of FIG. 15;
FIG. 17 is a front, top, left perspective, exploded view of an electronic meter of FIG. 15 showing a port plug removed;
FIG. 18 is a front elevational view of FIG. 15 showing a port plug removed;

FIG. 19 is a front, top, left perspective view of an electronic meter according to a fourth embodiment;
FIG. 20 is a front elevational view of FIG. 19;
FIG. 21 is a front, top, left perspective, exploded view of an electronic meter of FIG. 19 showing a port plug removed;
FIG. 22 is a front elevational view of FIG. 19 showing a port plug removed;
FIG. 23 is a front, top, left perspective view of an electronic meter according to a fifth embodiment;
FIG. 24 is a front elevational view of FIG. 23;
FIG. 25 is a front, top, left perspective, exploded view of an electronic meter of FIG. 23 showing a port plug removed;
FIG. 26 is a front elevational view of FIG. 23 showing a port plug removed;
FIG. 27 is a front, top, left perspective view of an electronic meter according to a sixth embodiment;
FIG. 28 is a front elevational view of FIG. 27;
FIG. 29 is a front, top, left perspective, exploded view of an electronic meter of FIG. 27 showing a port plug removed;
FIG. 30 is a front elevational view of FIG. 27 showing a port plug removed;
FIG. 31 is a front, top, left perspective view of an electronic meter according to a seventh embodiment;
FIG. 32 is a front elevational view of FIG. 31;
FIG. 33 is a front, top, left perspective, exploded view of an electronic meter of FIG. 31 showing a port plug removed;
FIG. 34 is a front elevational view of FIG. 31 showing a port plug removed;
FIG. 35 is a front, top, left perspective view of a port plug;
FIG. 36 is a rear, top, left perspective view of a port plug of FIG. 35;
FIG. 37 is a top plan view of a port plug of FIG. 35;
FIG. 38 is a rear elevational view of a port plug of FIG. 35;
FIG. 39 is a right side elevational view of a port plug of FIG. 35;
FIG. 40 is a left side elevational view of a port plug of FIG. 35;
FIG. 41 is a front elevational view of a port plug of FIG. 35;
and,
FIG. 42 is a bottom plan view of a port plug of FIG. 35.
The broken lines showing in FIGS. 1-42 are for illustrative purposes only and form no part of the claimed design.

1 Claim, 36 Drawing Sheets

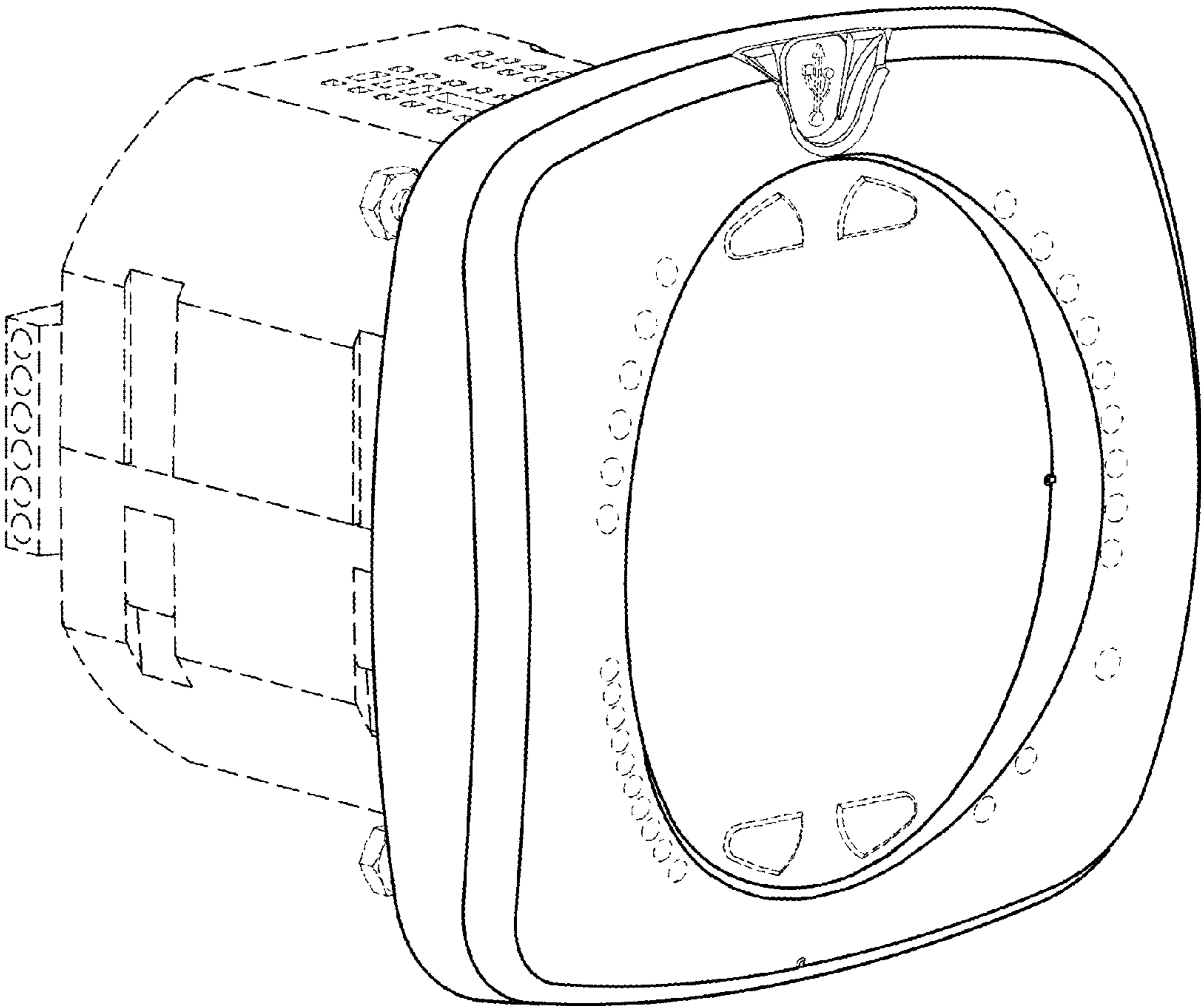

FIG. 1

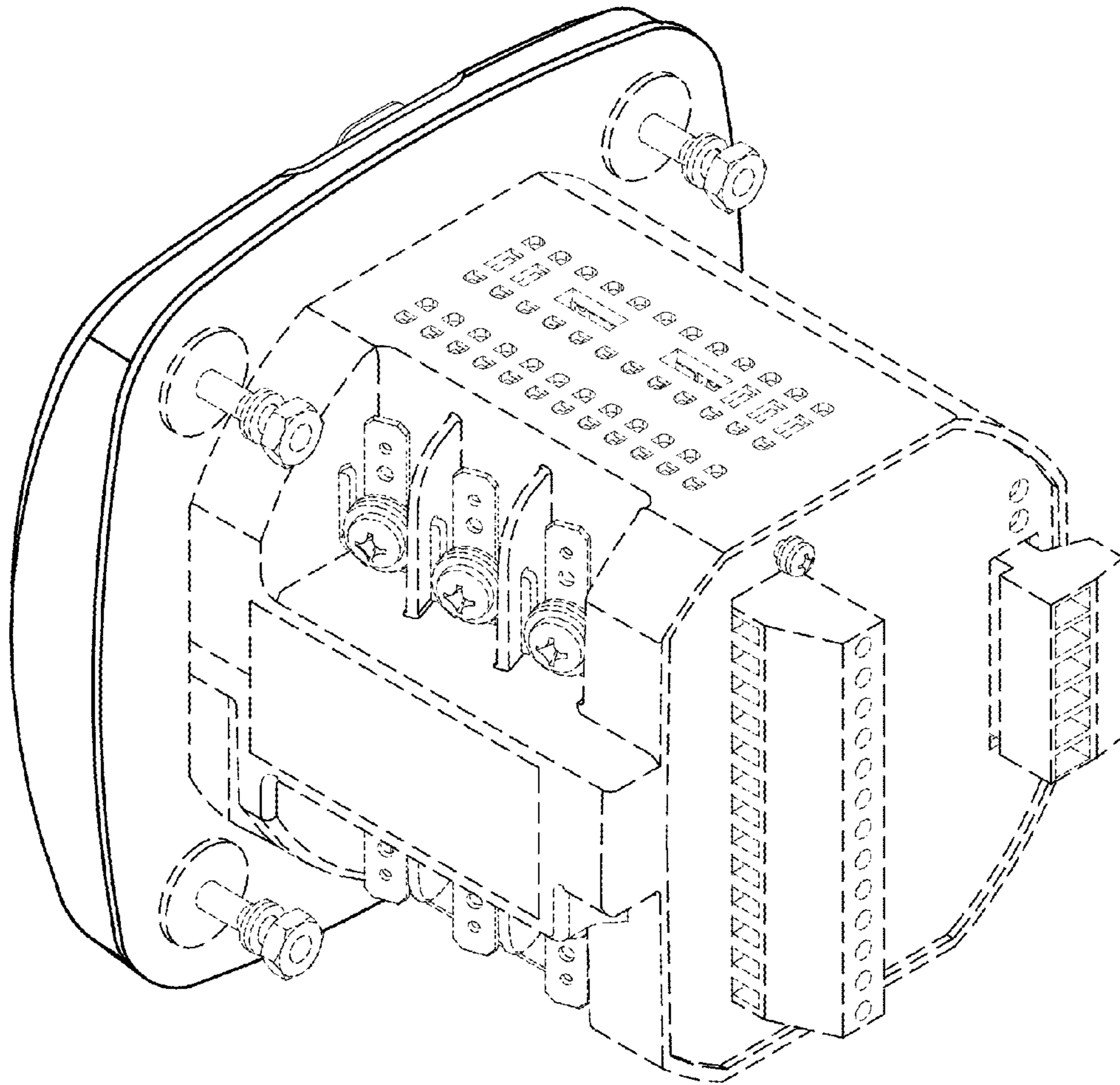

FIG.2

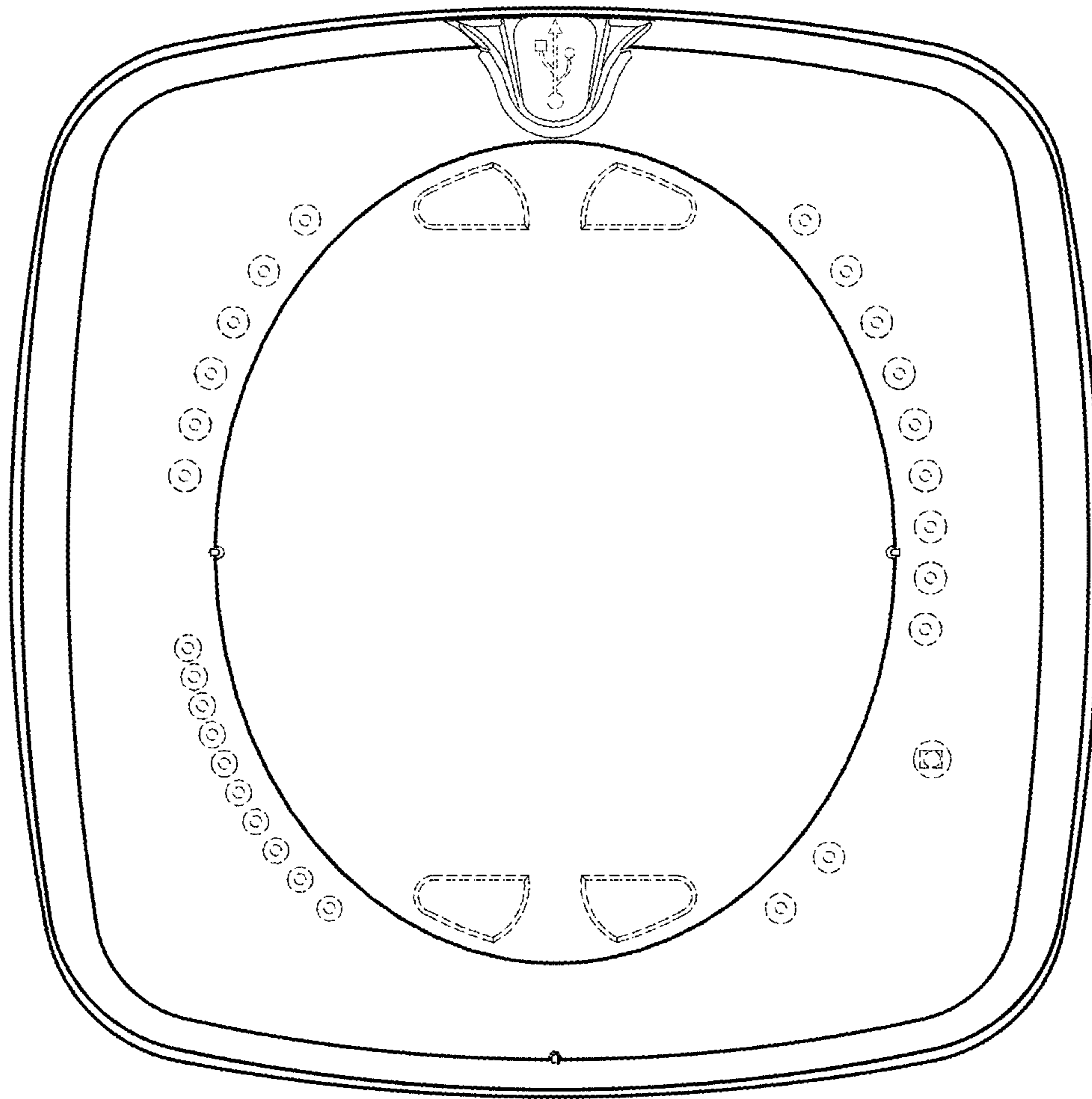

FIG.3

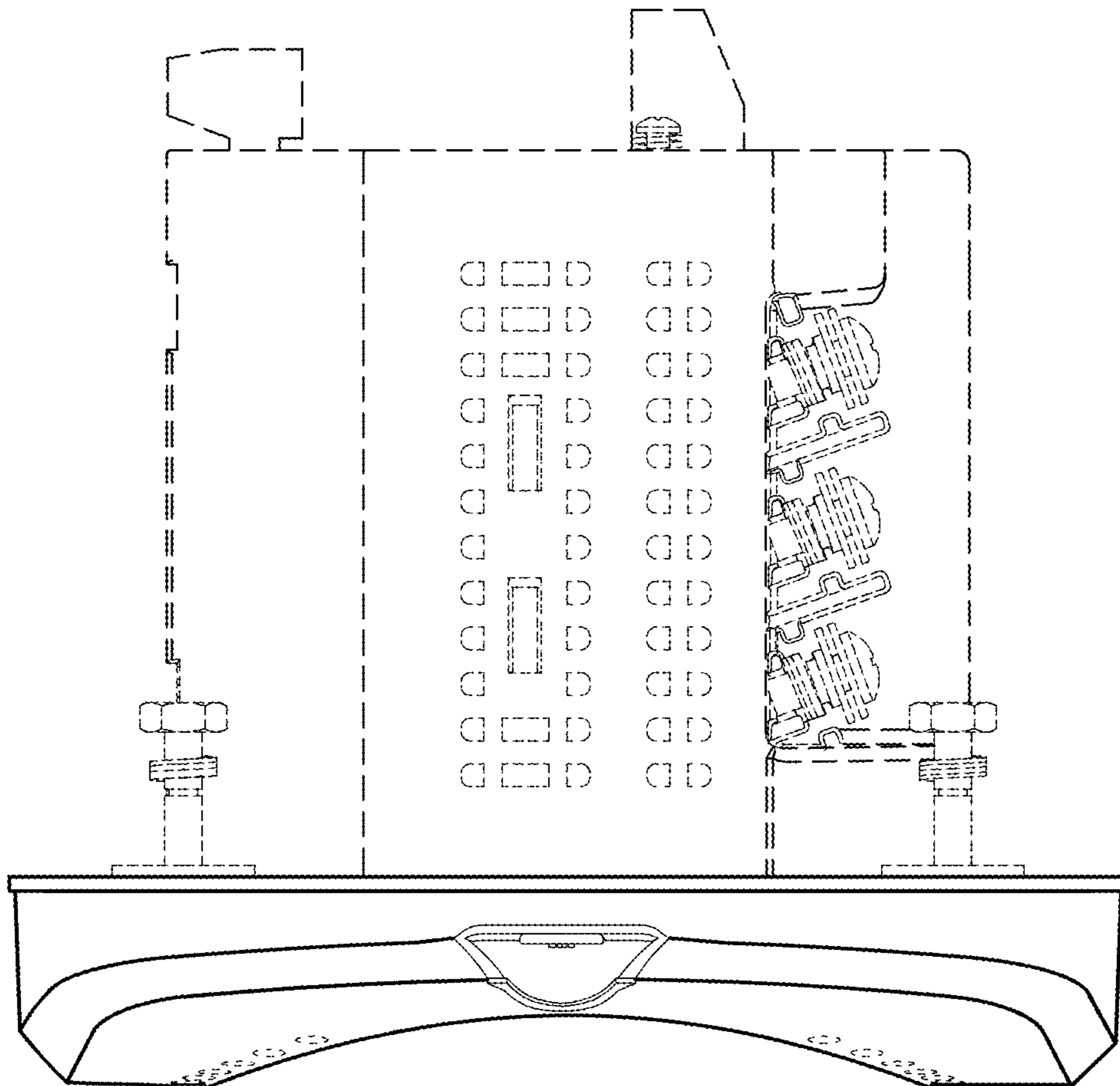

FIG. 4

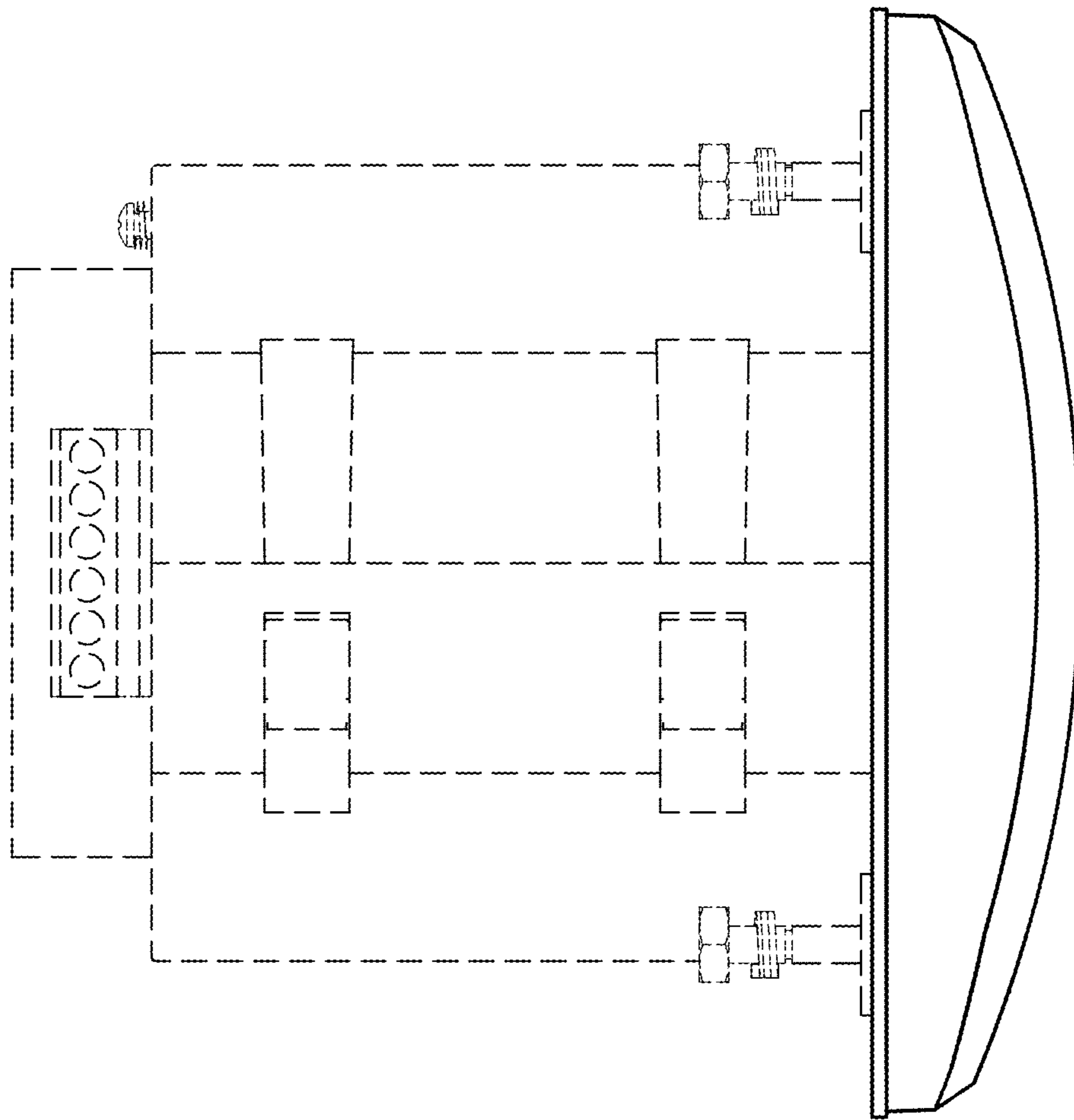

FIG.5

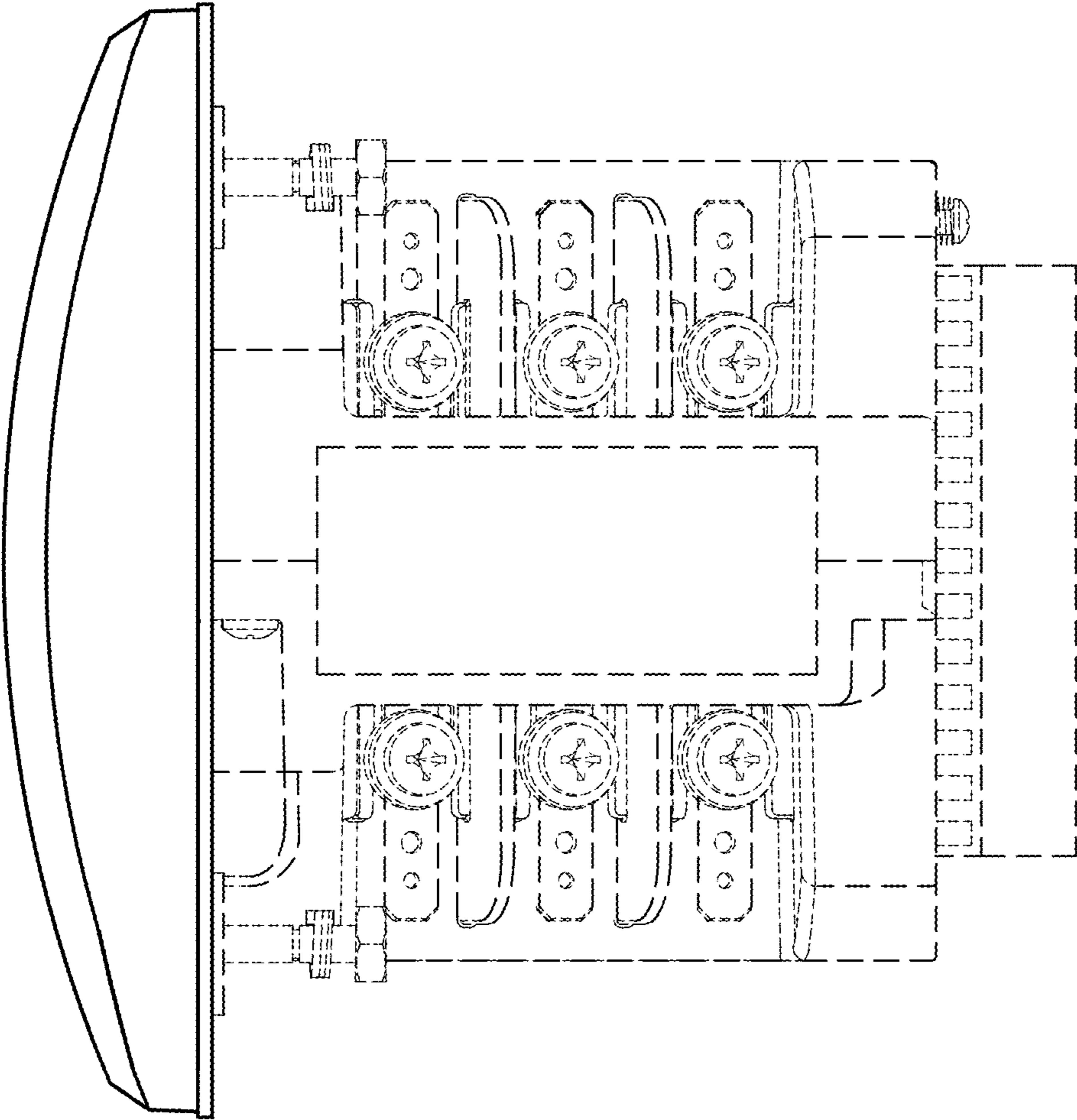

FIG.6

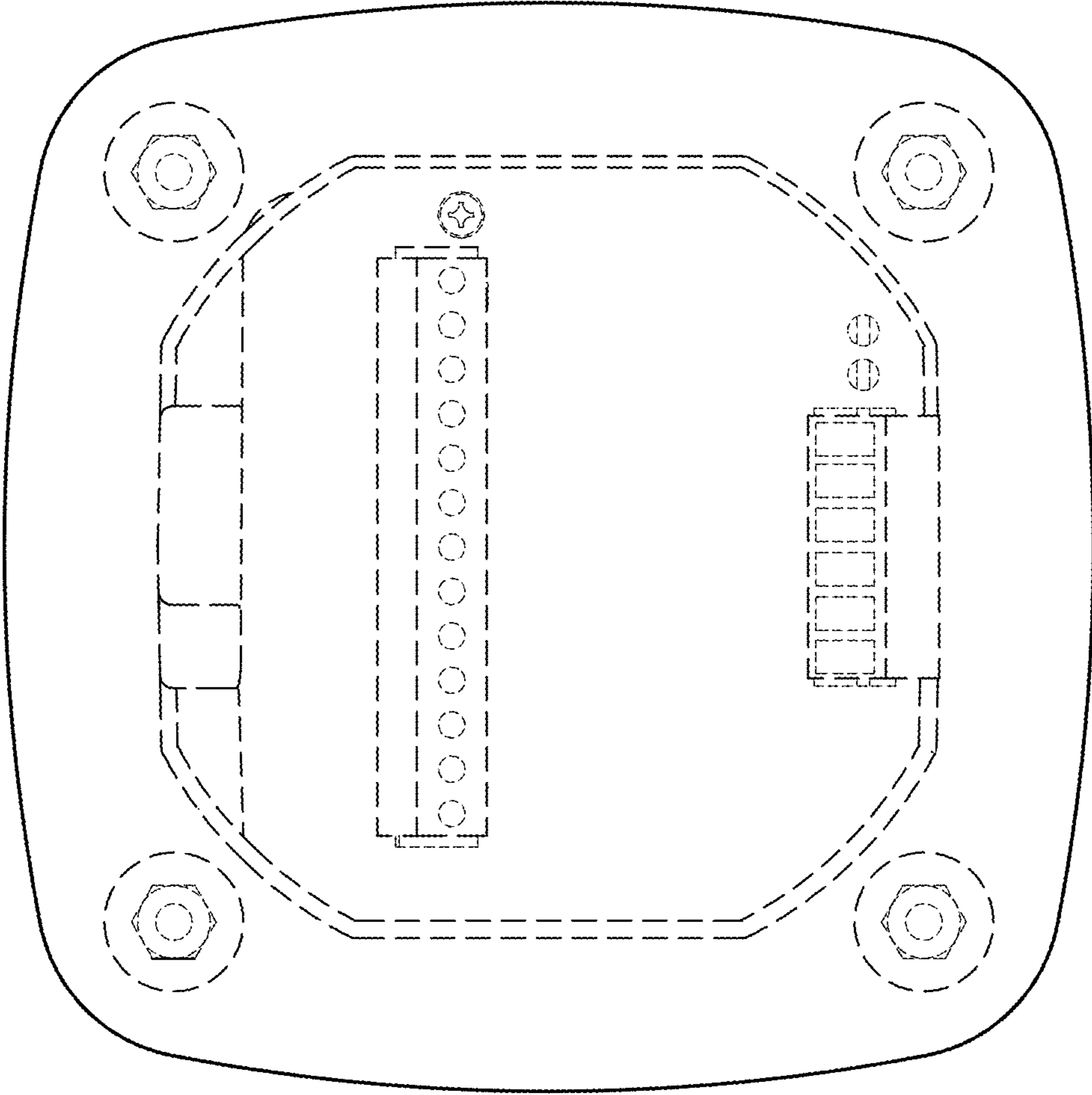

FIG.7

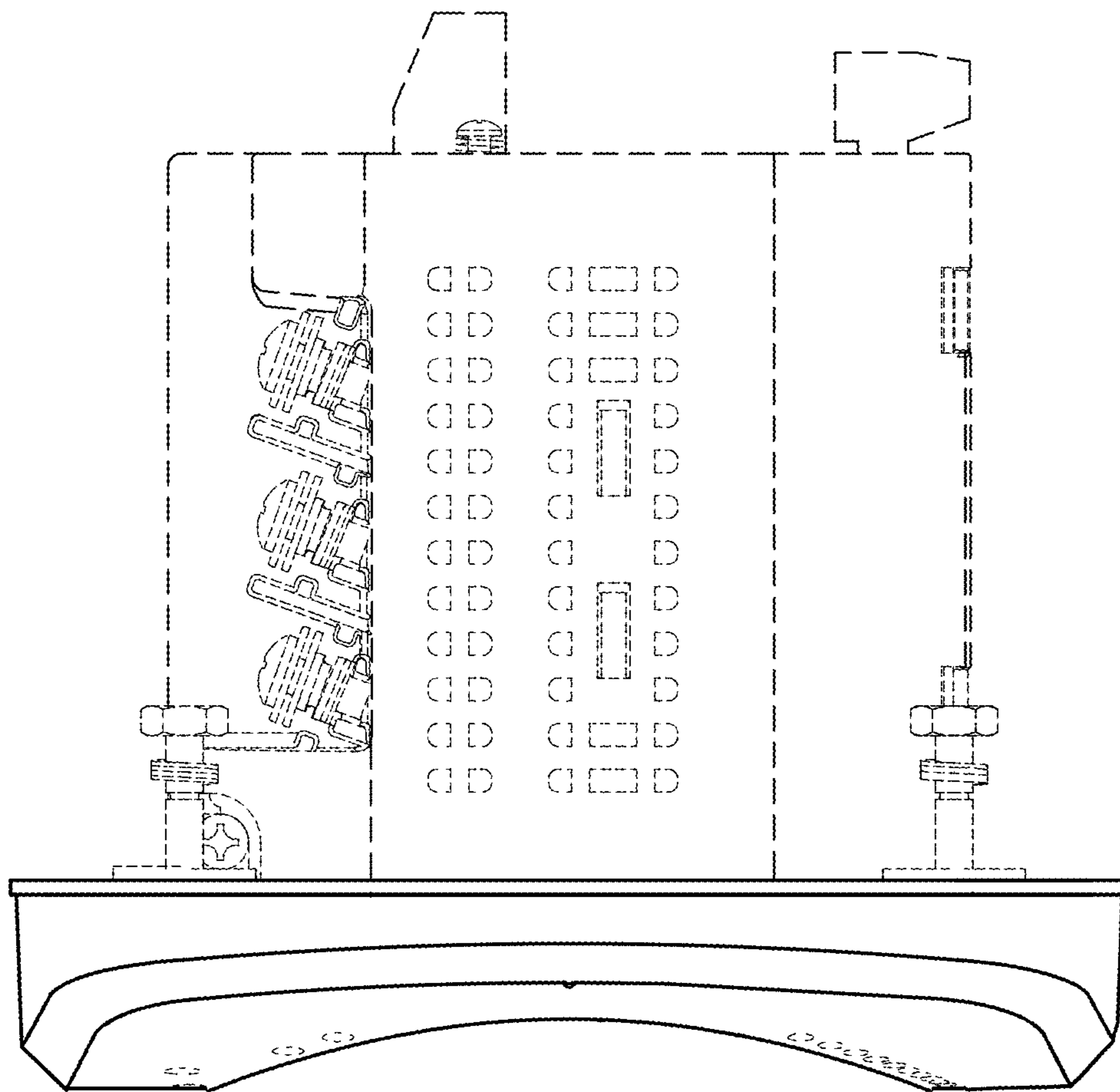

FIG.8

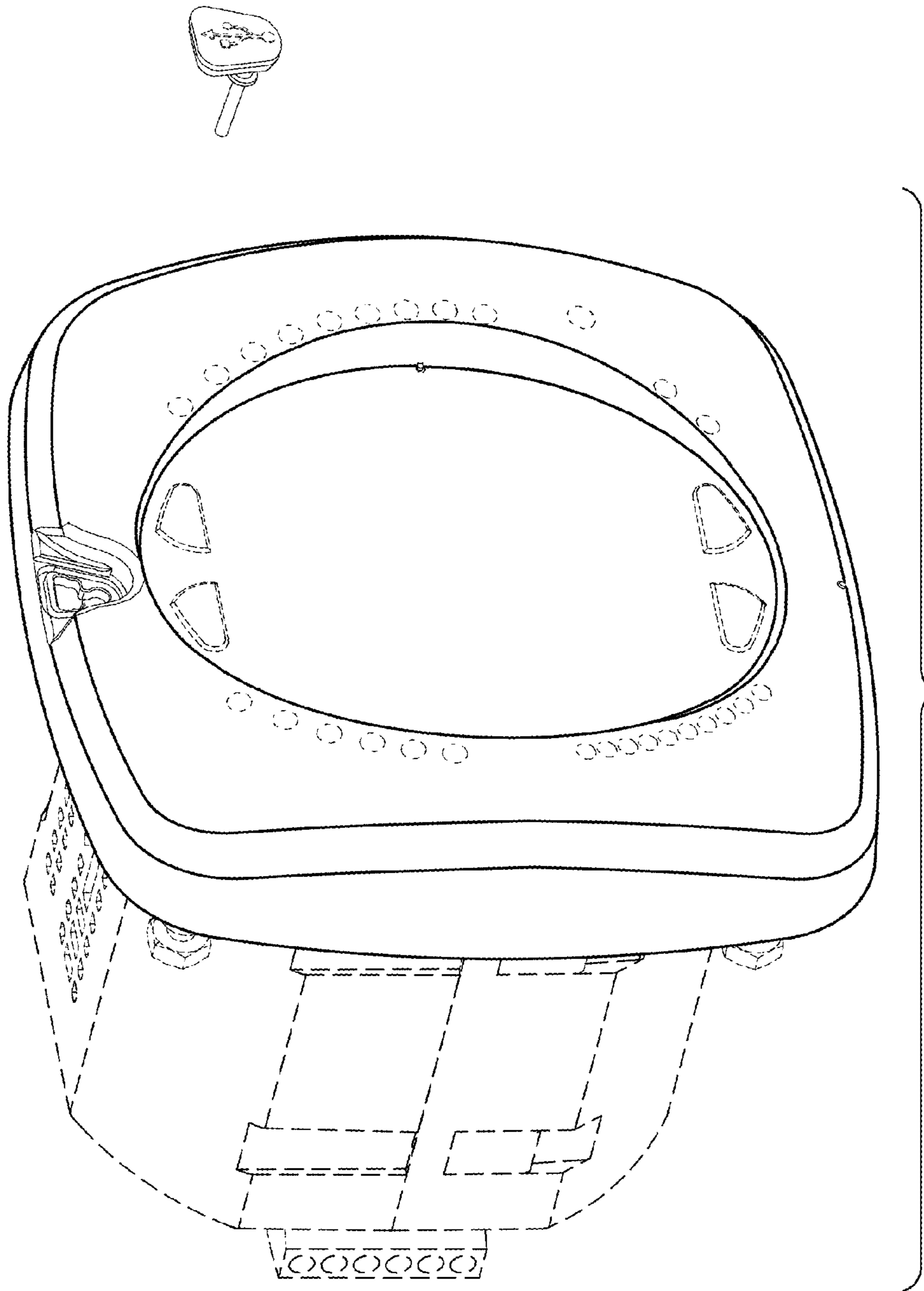

FIG. 9

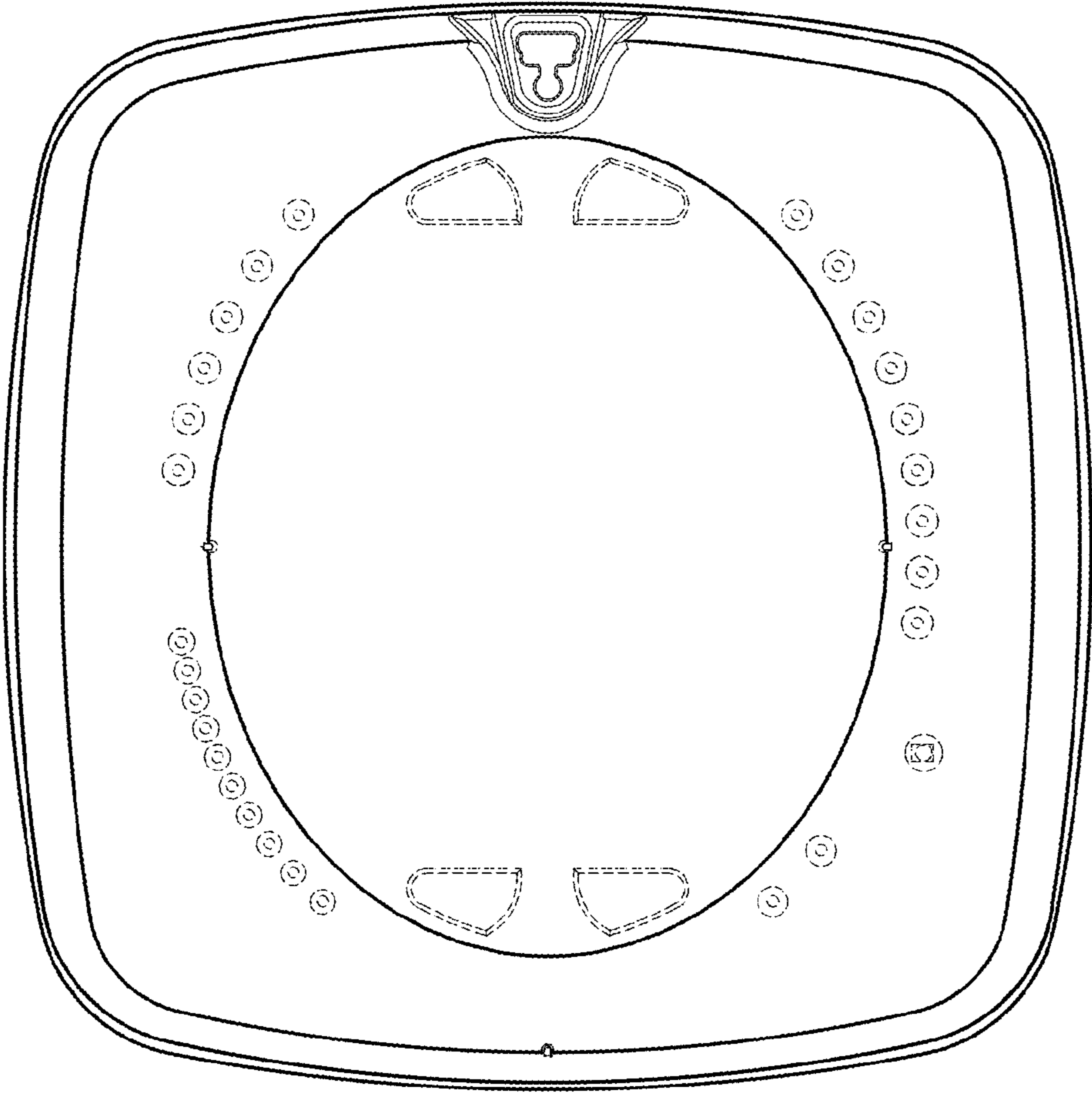

FIG. 10

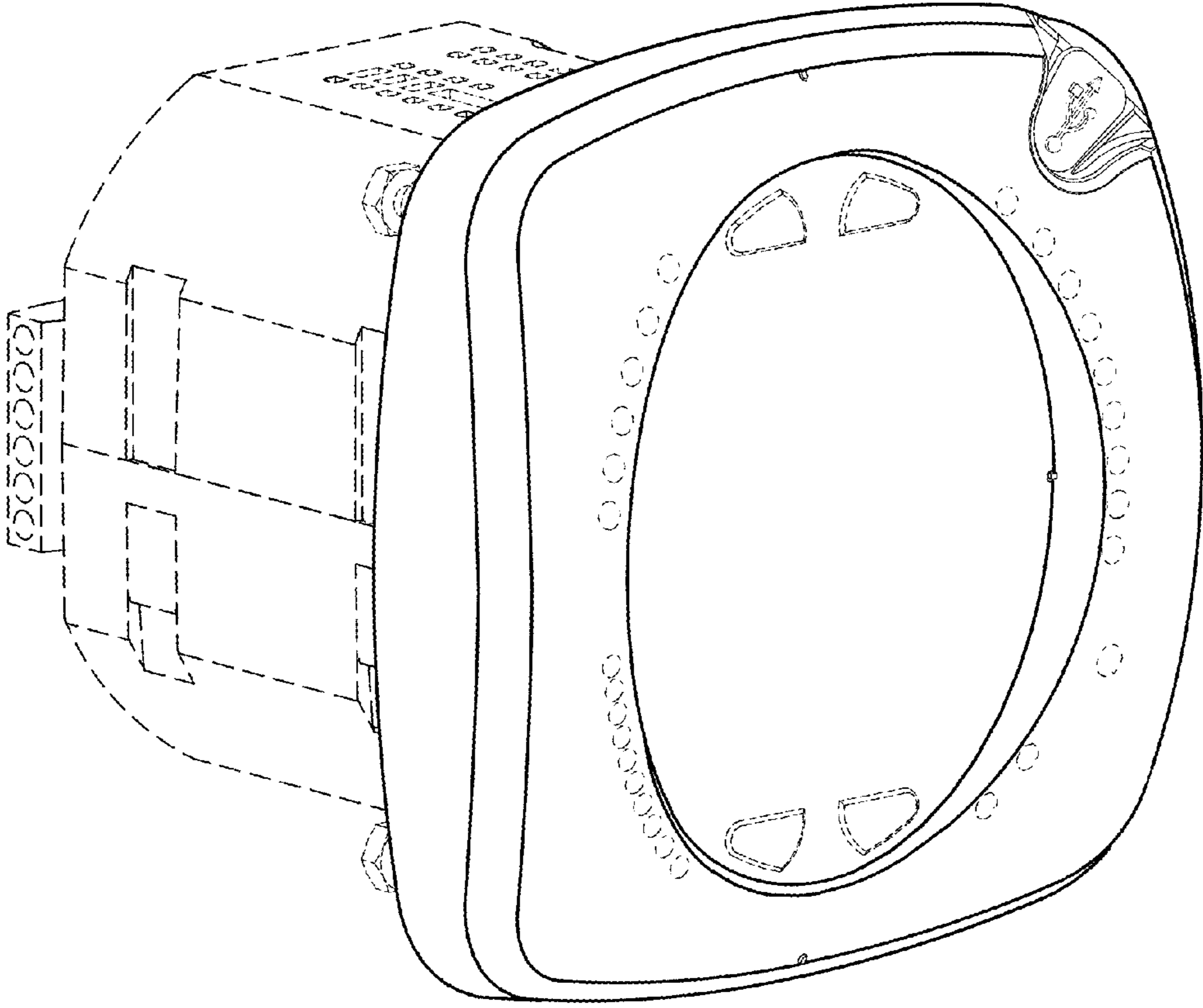

FIG. 11

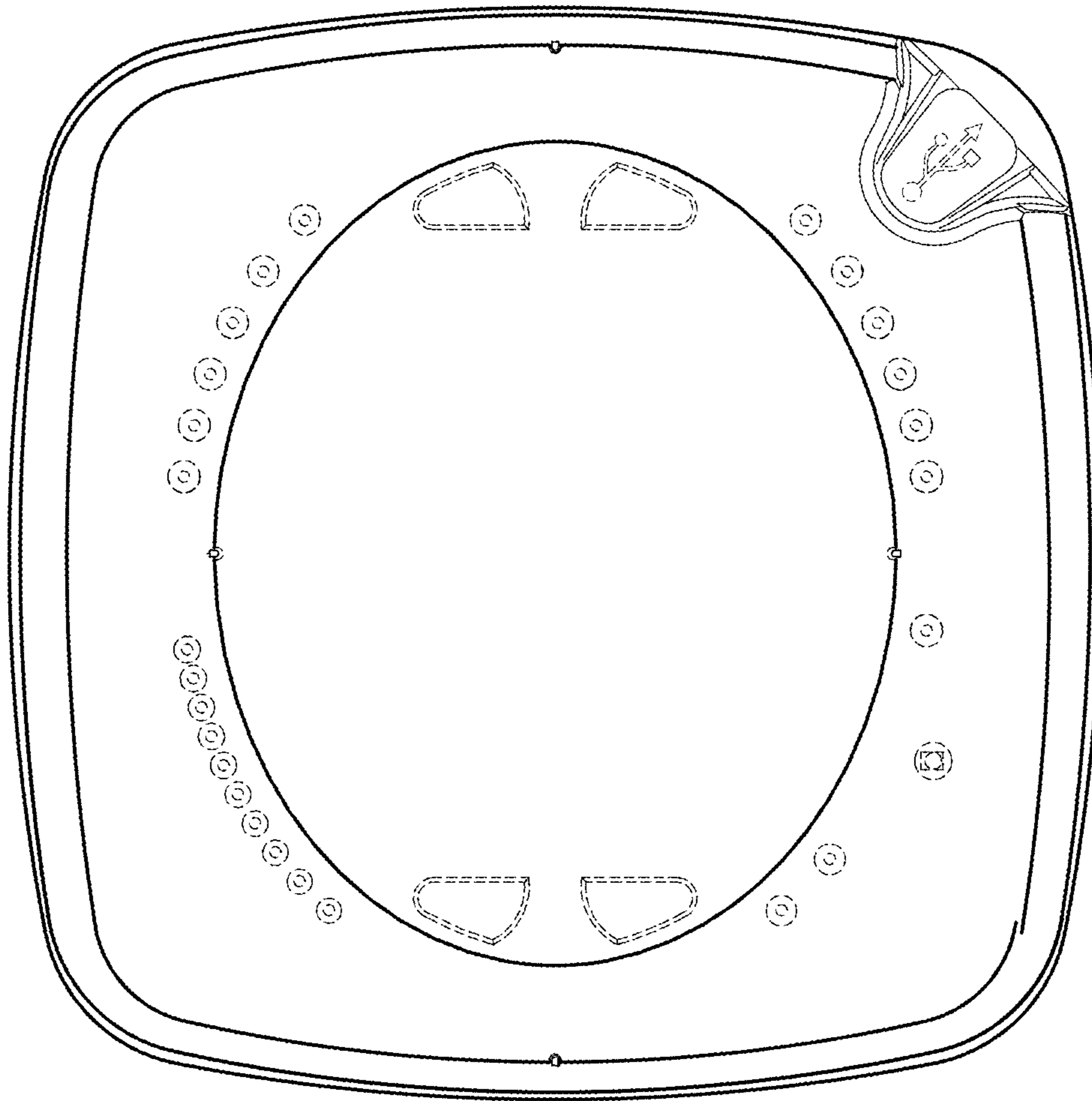

FIG. 12

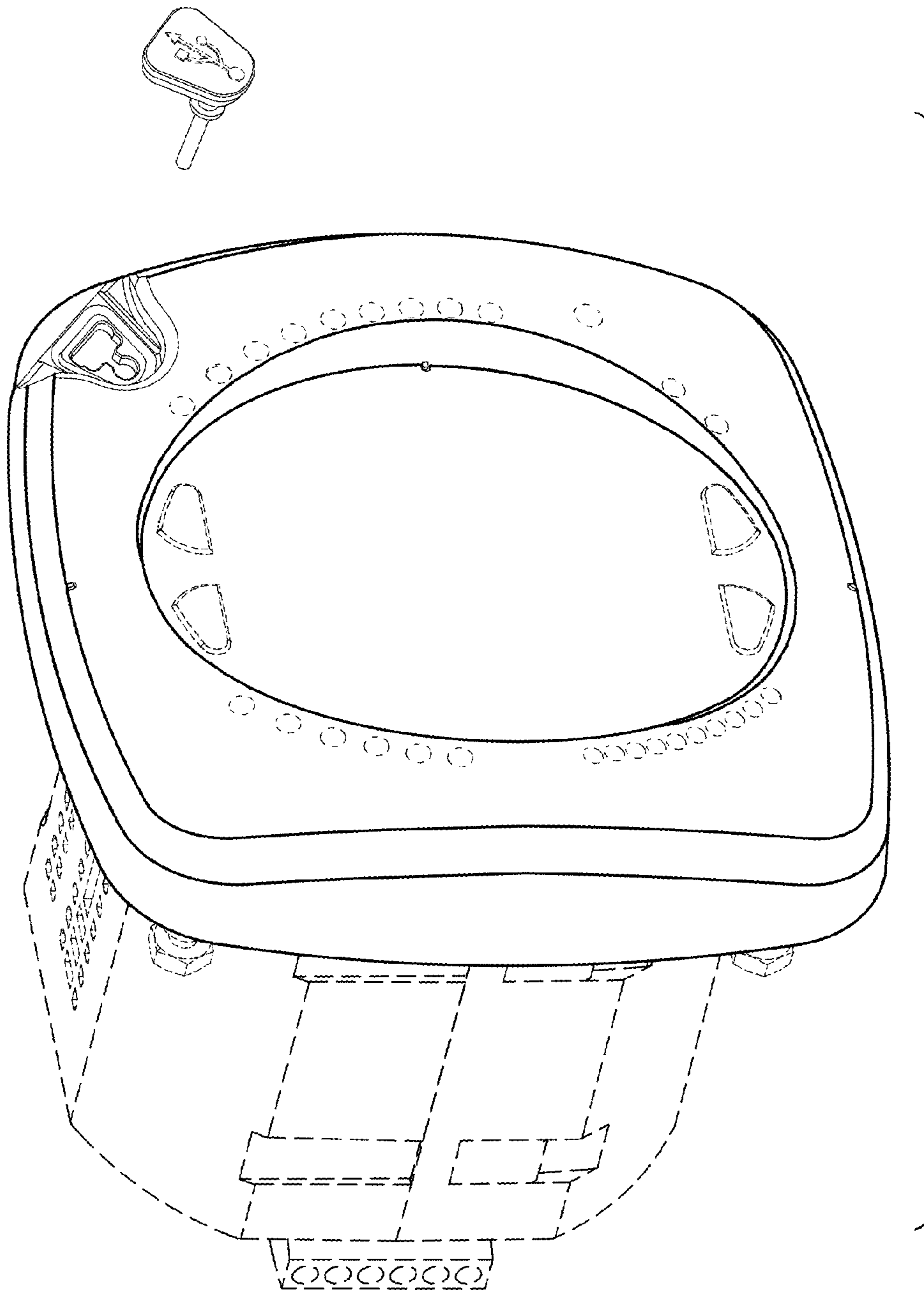

FIG. 13

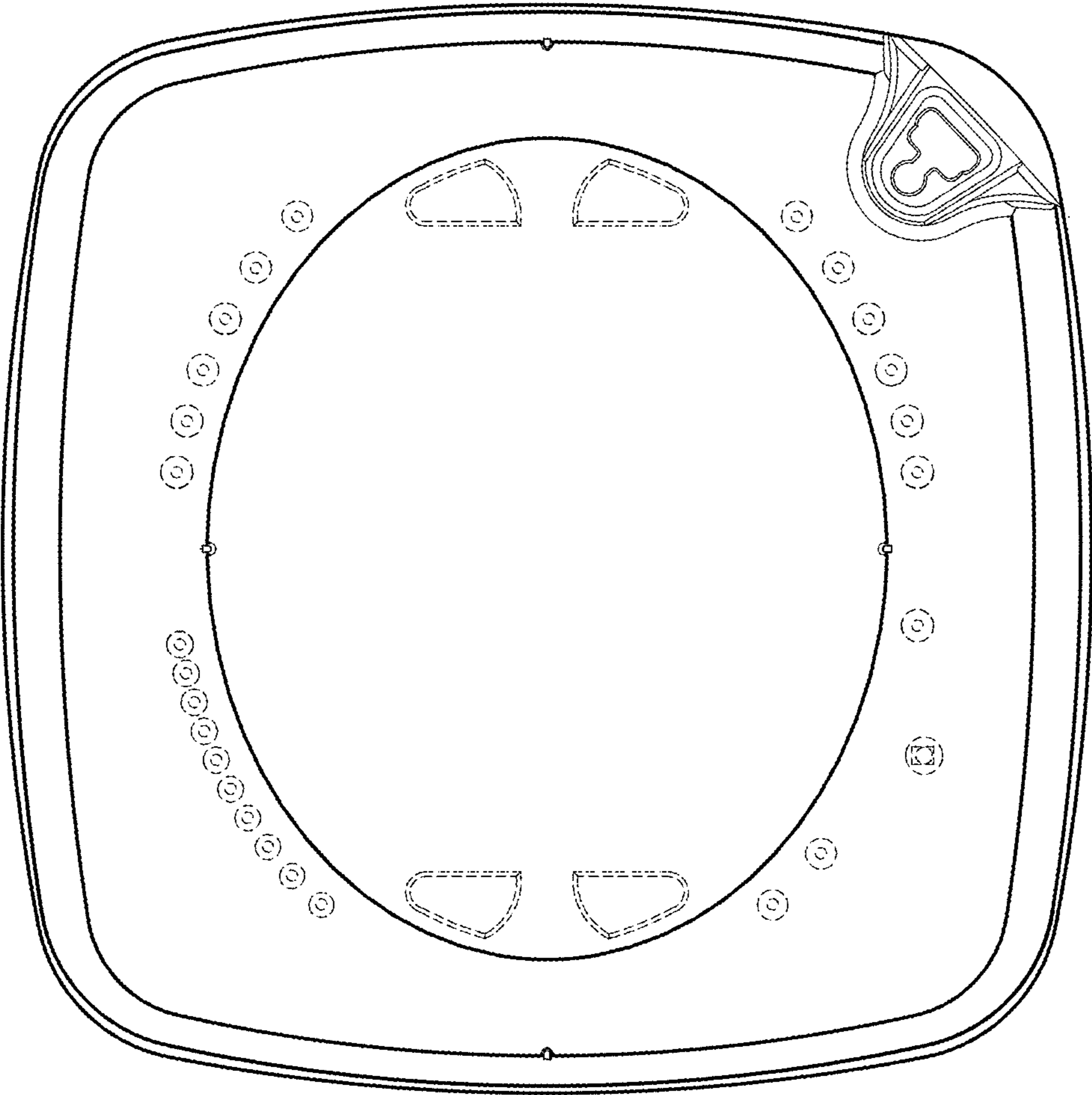

FIG.14

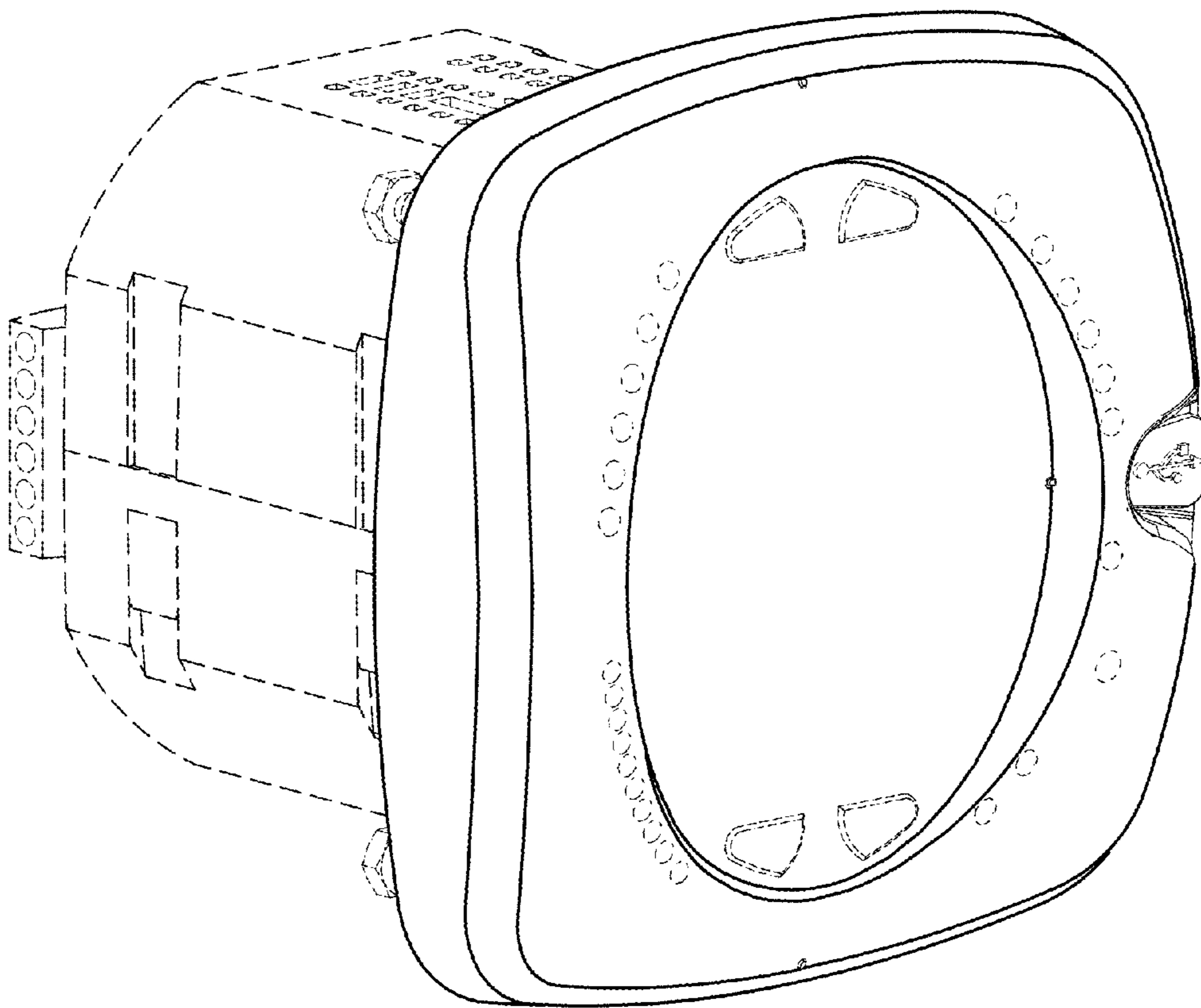

FIG. 15

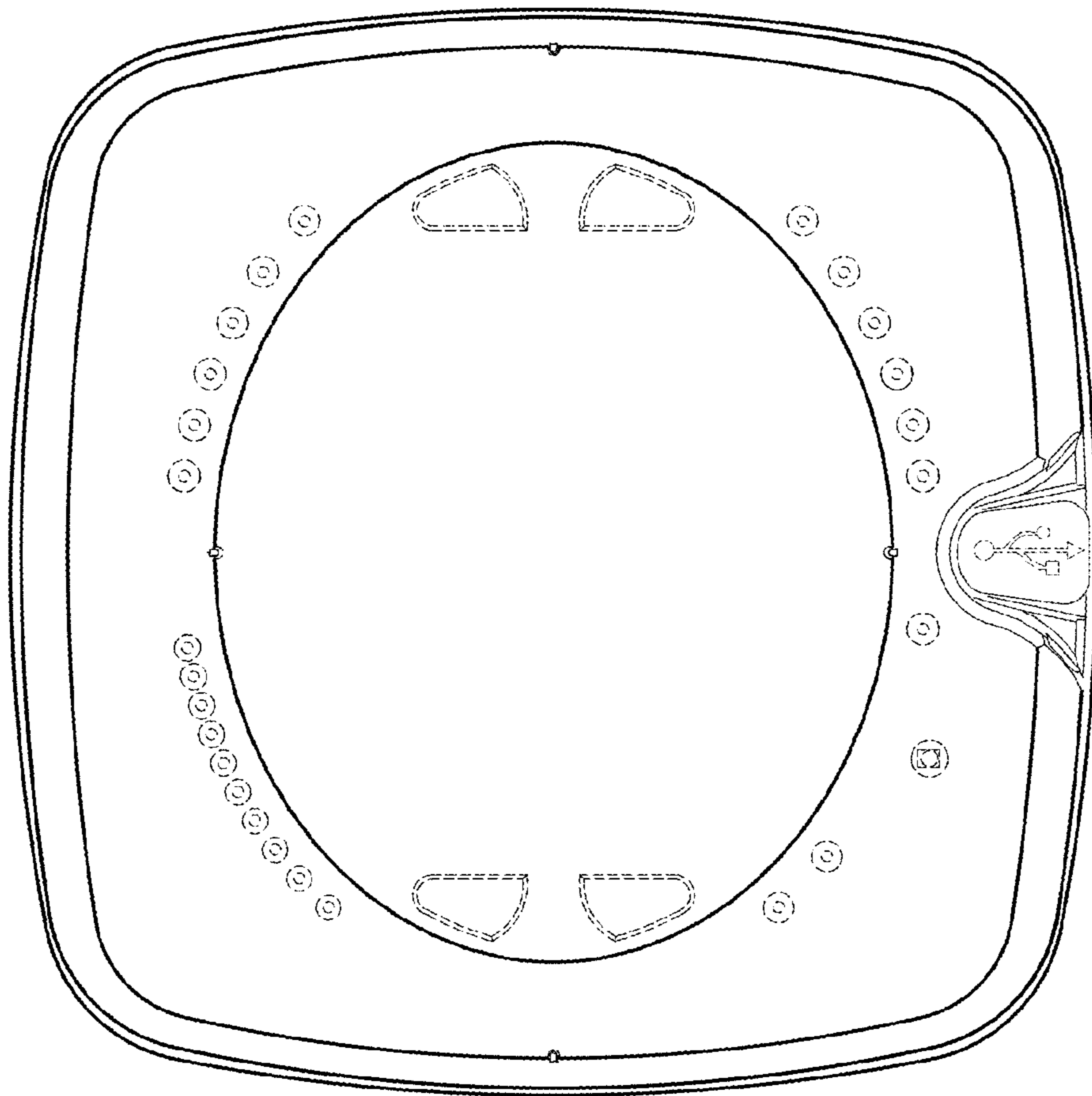

FIG. 16

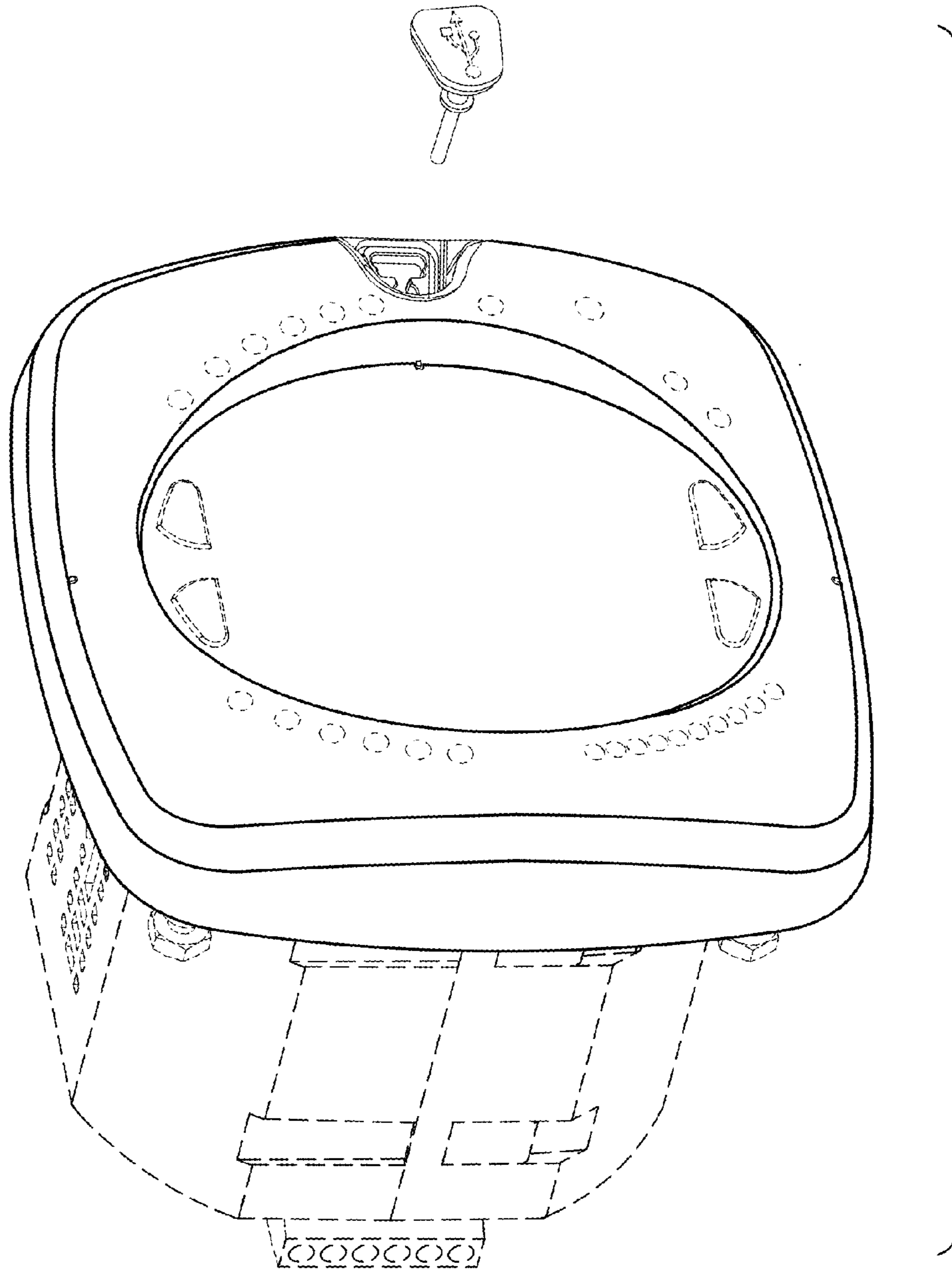

FIG.17

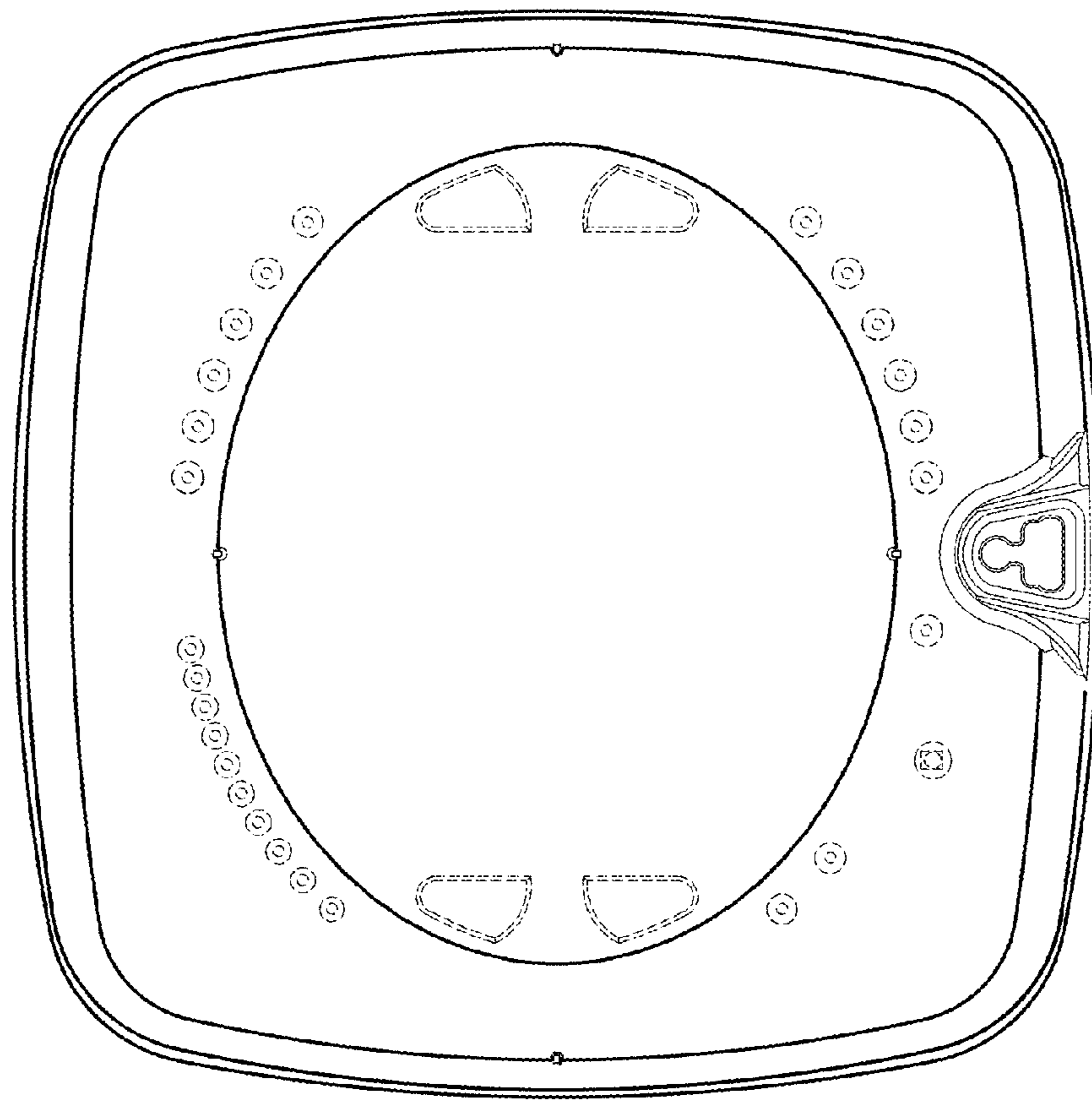

FIG. 18

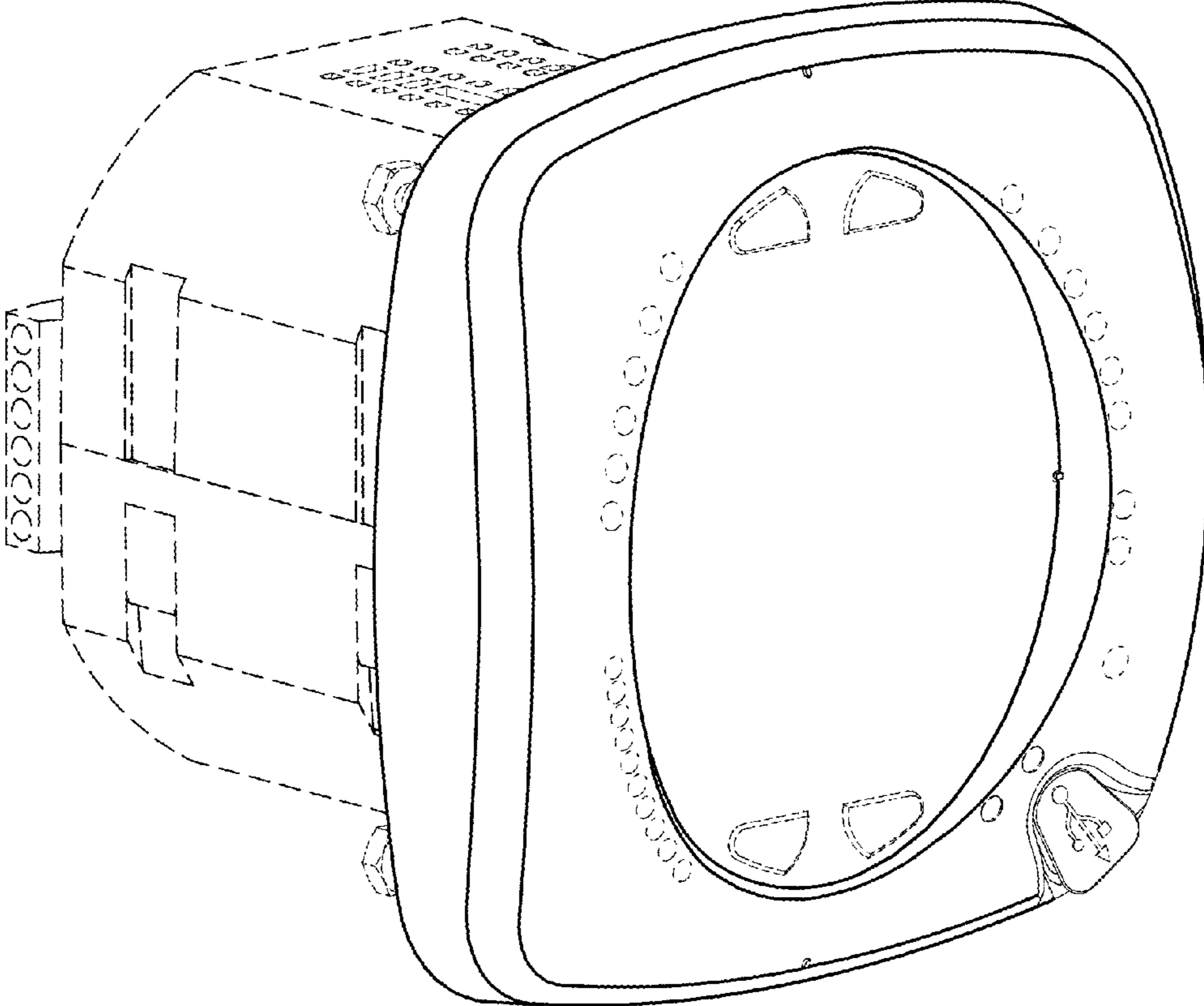

FIG.19

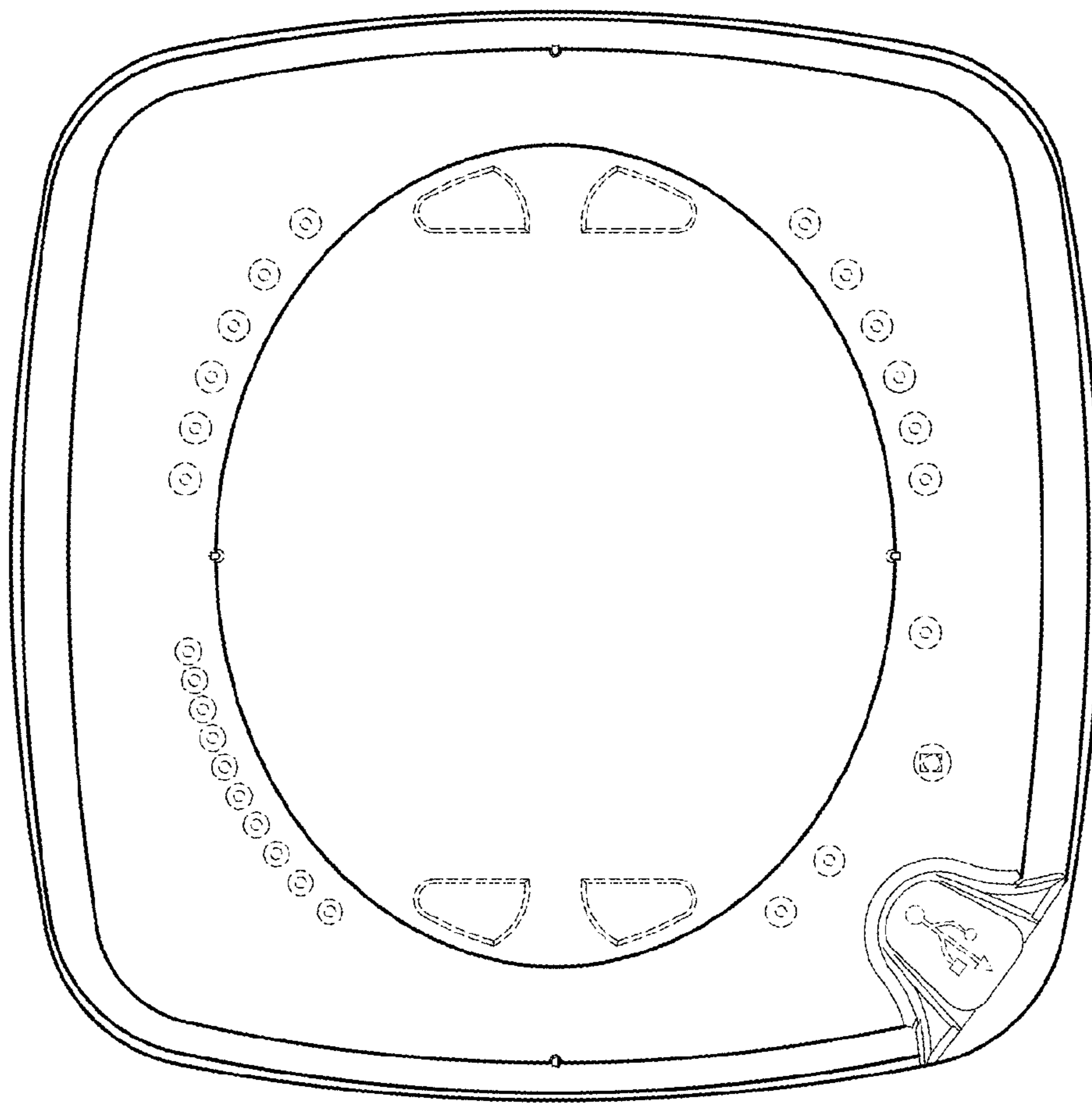

FIG.20

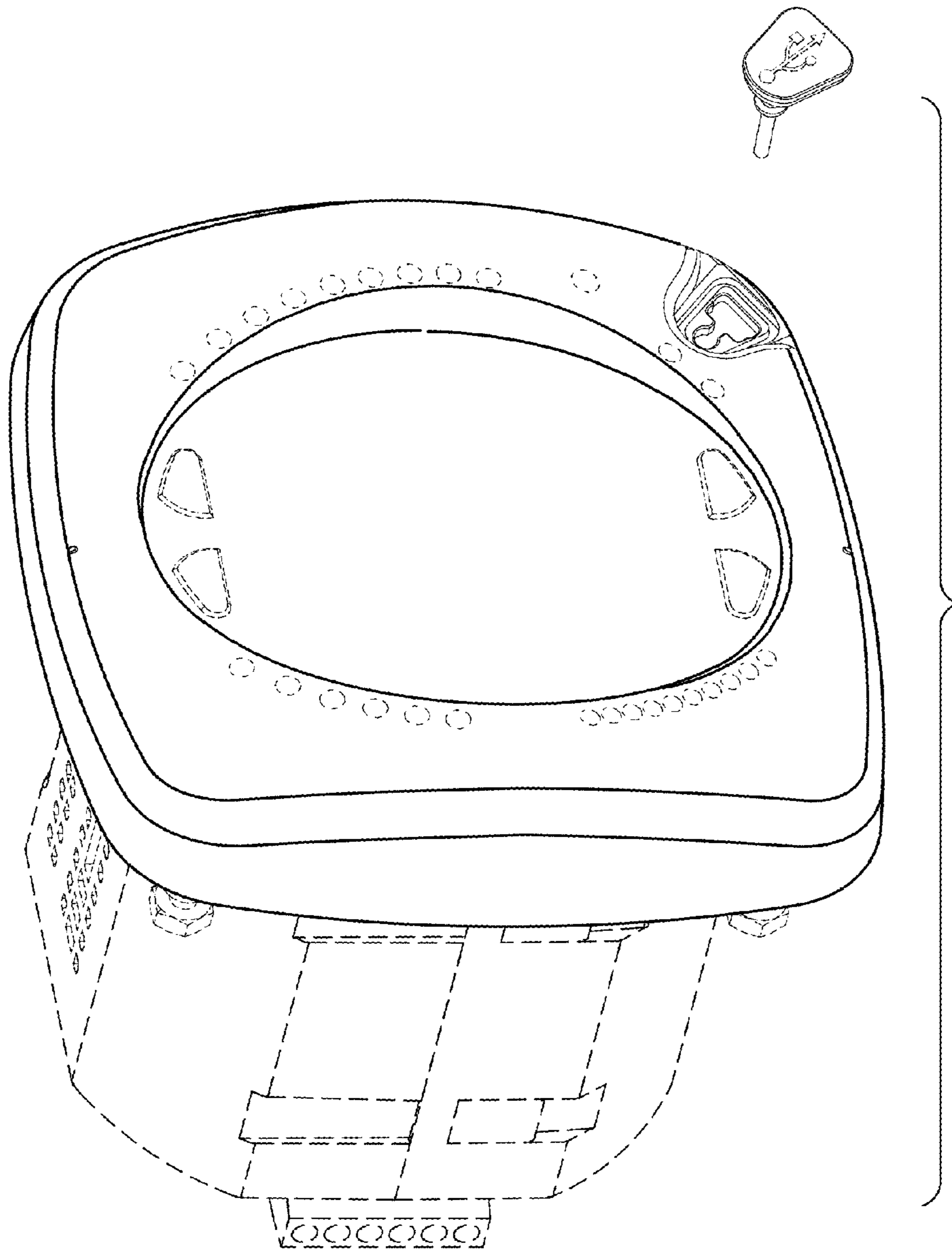

FIG.21

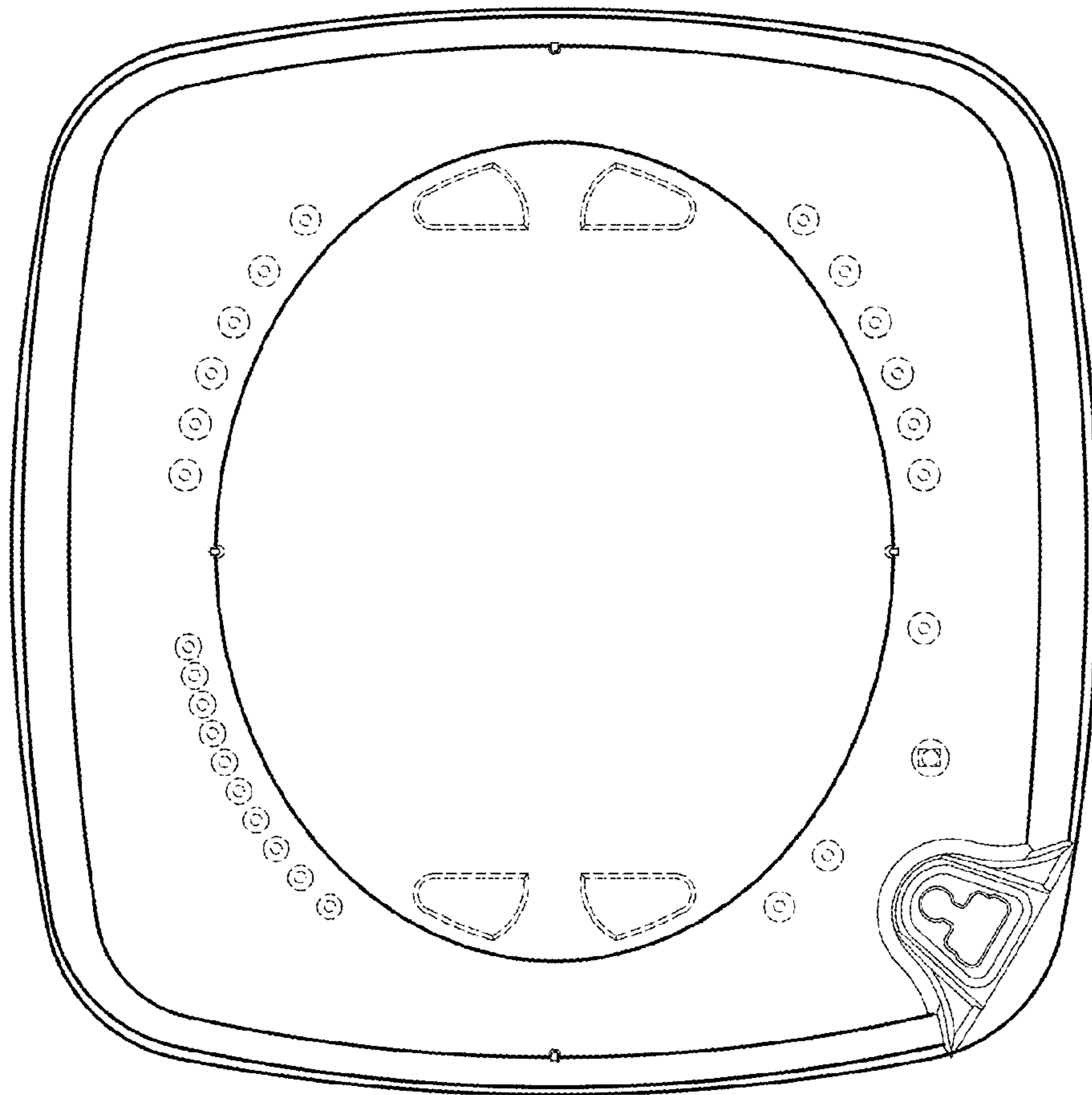

FIG.22

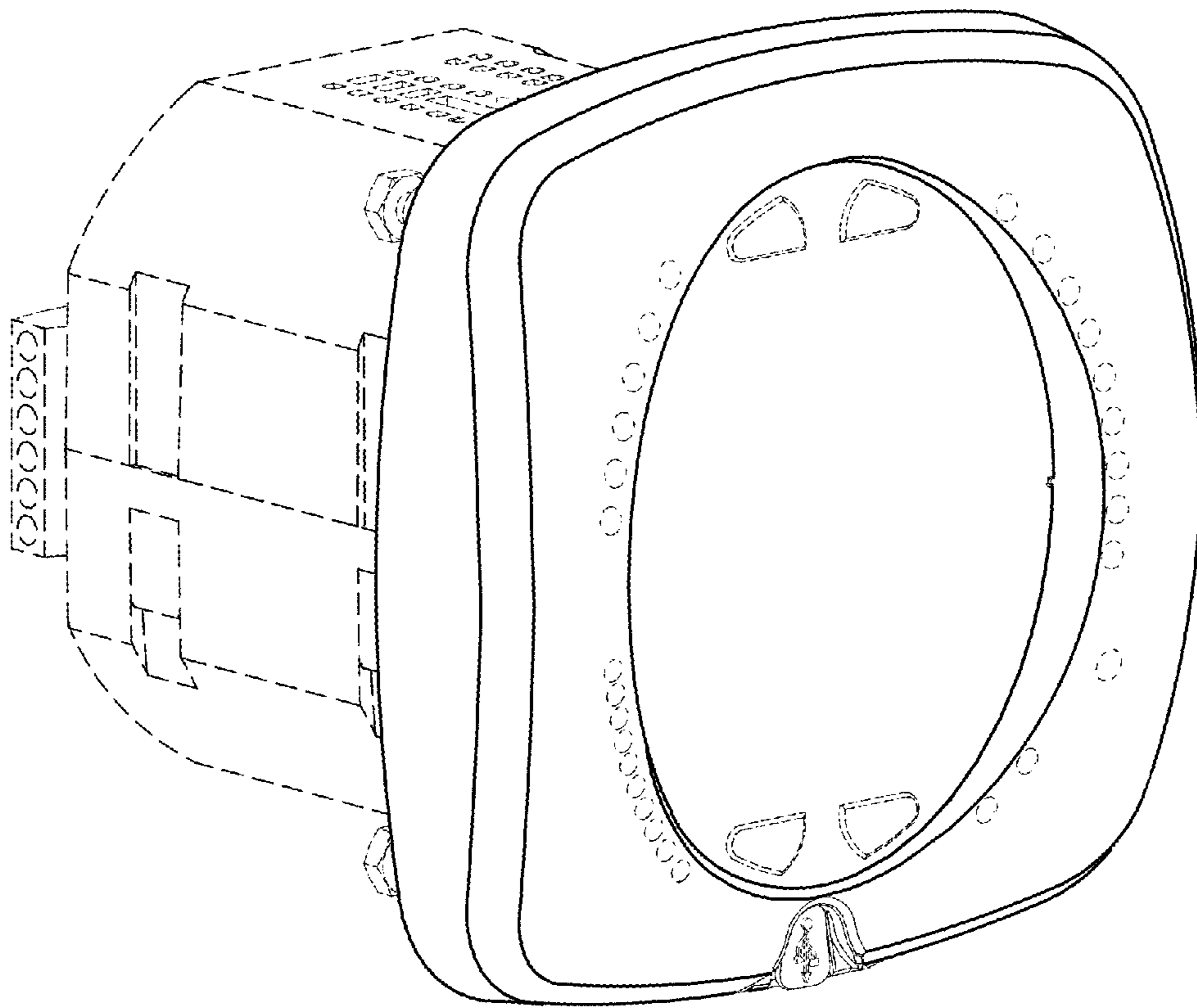

FIG.23

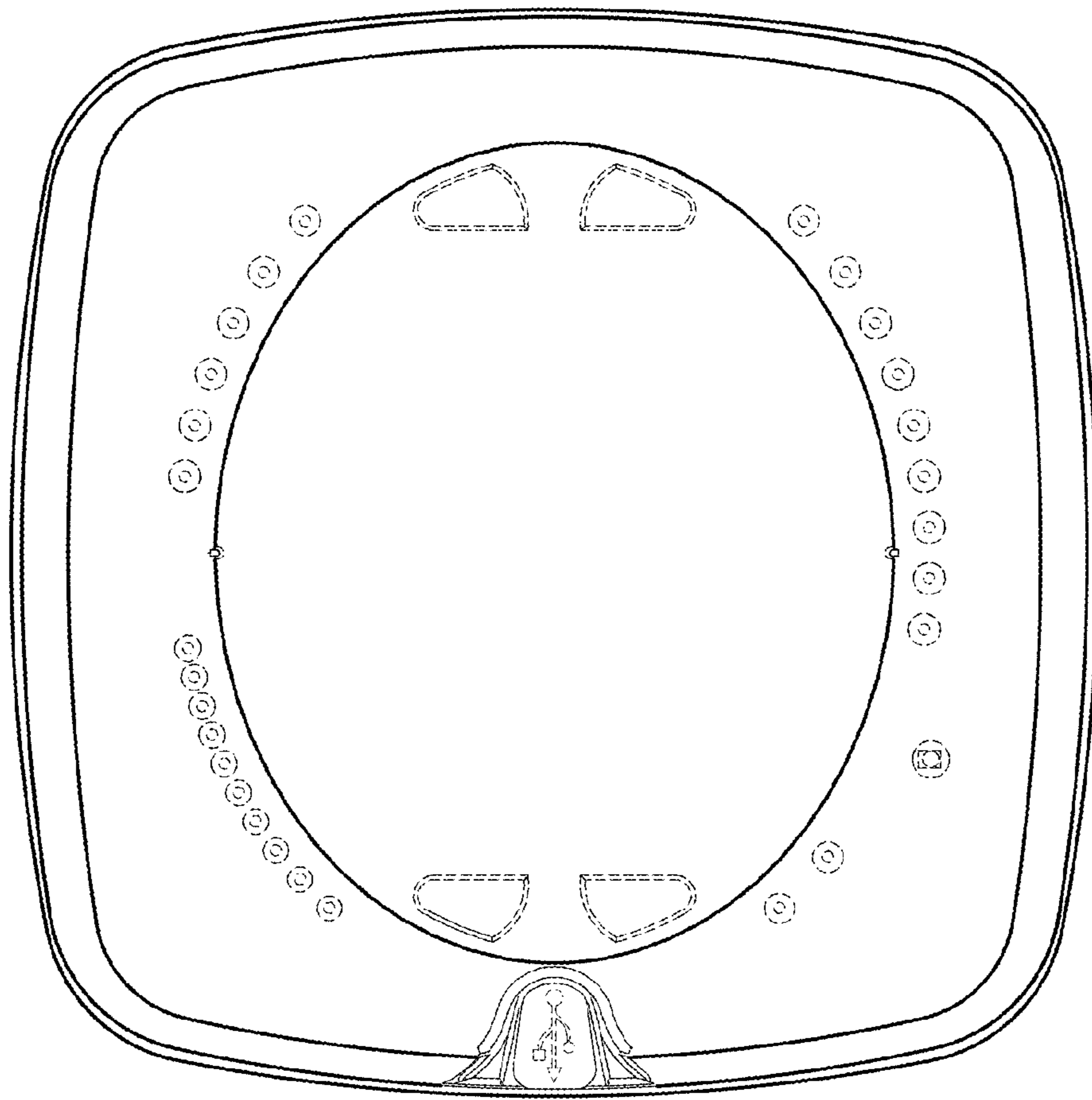

FIG.24

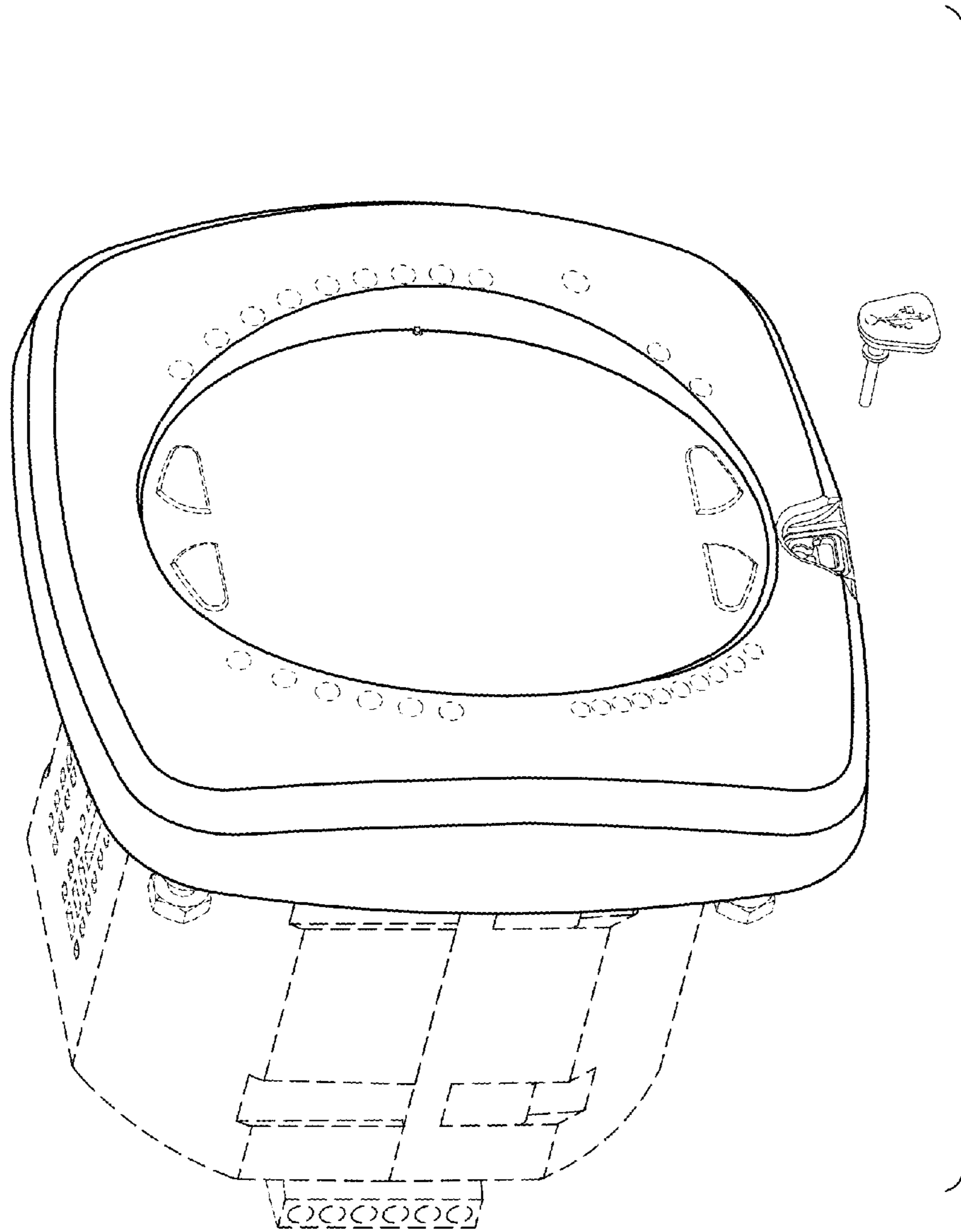

FIG.25

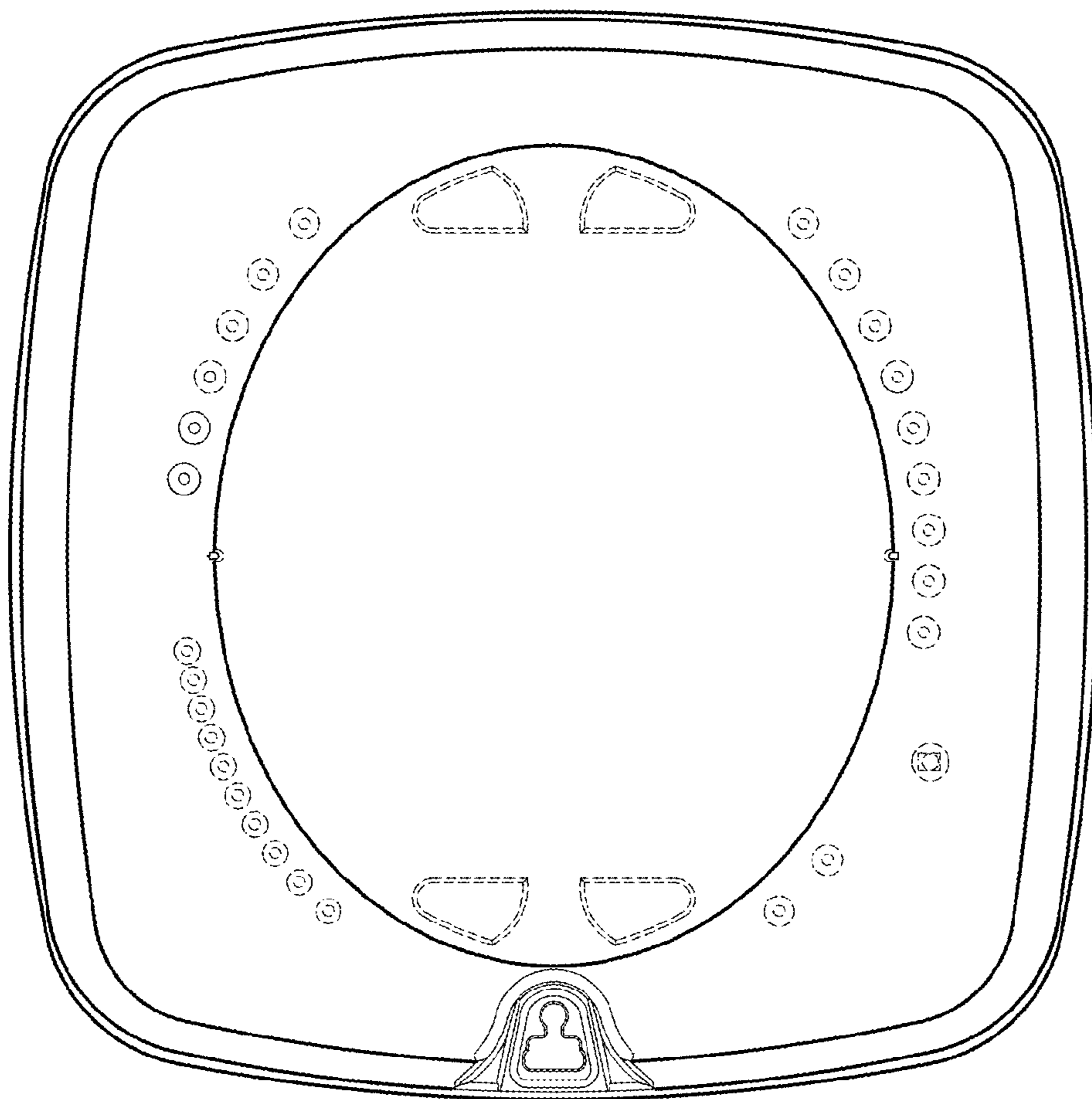

FIG.26

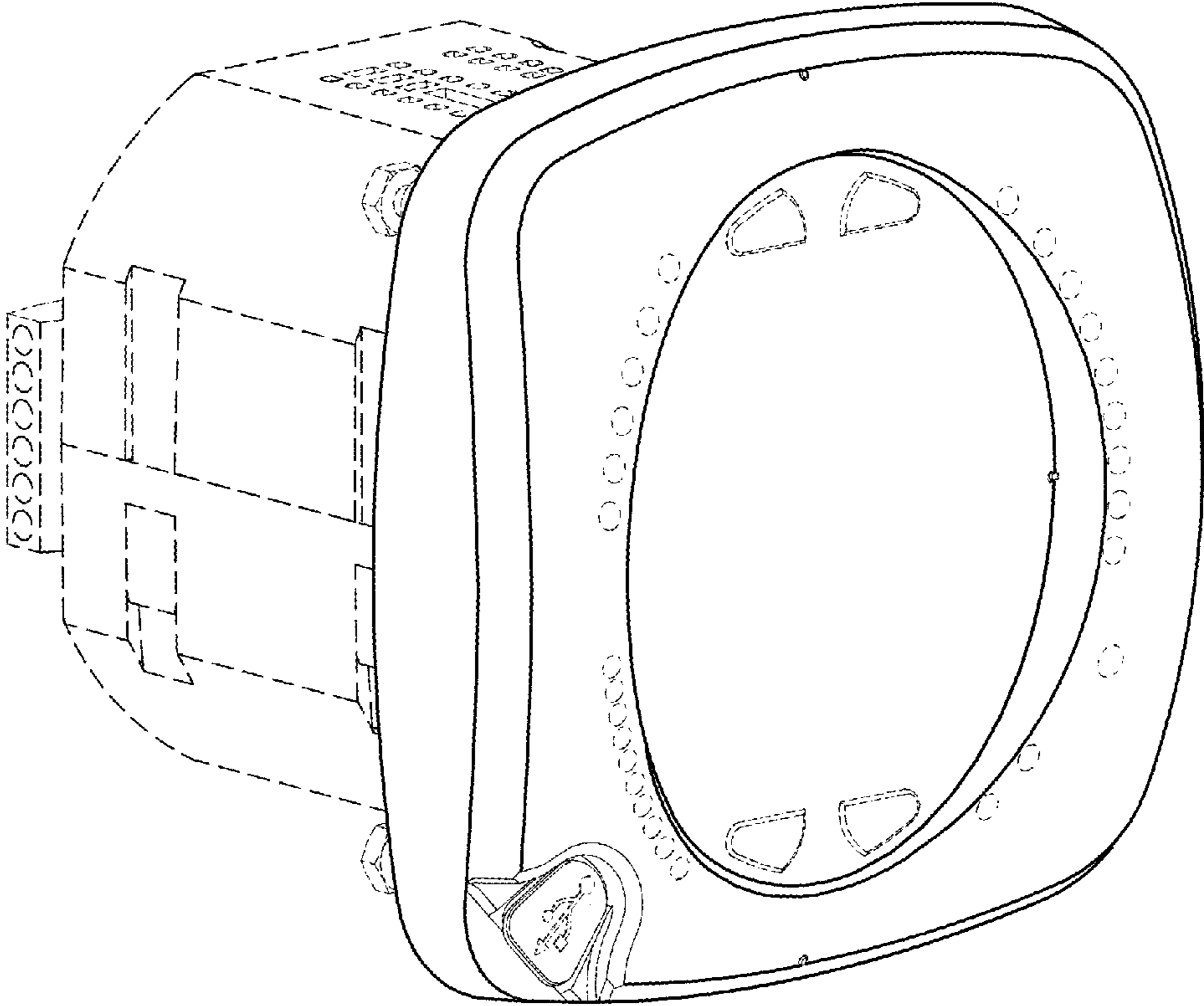

FIG.27

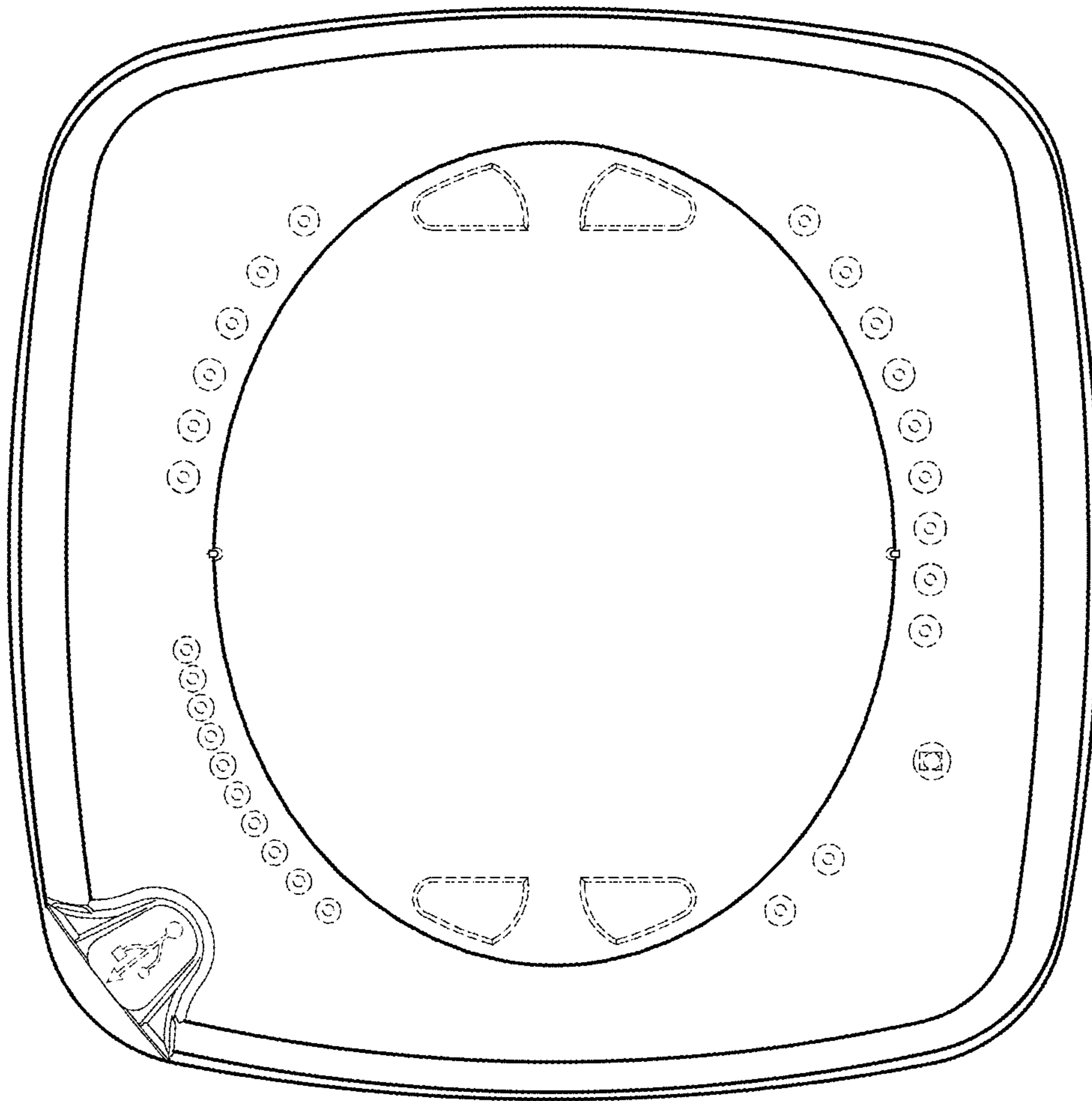
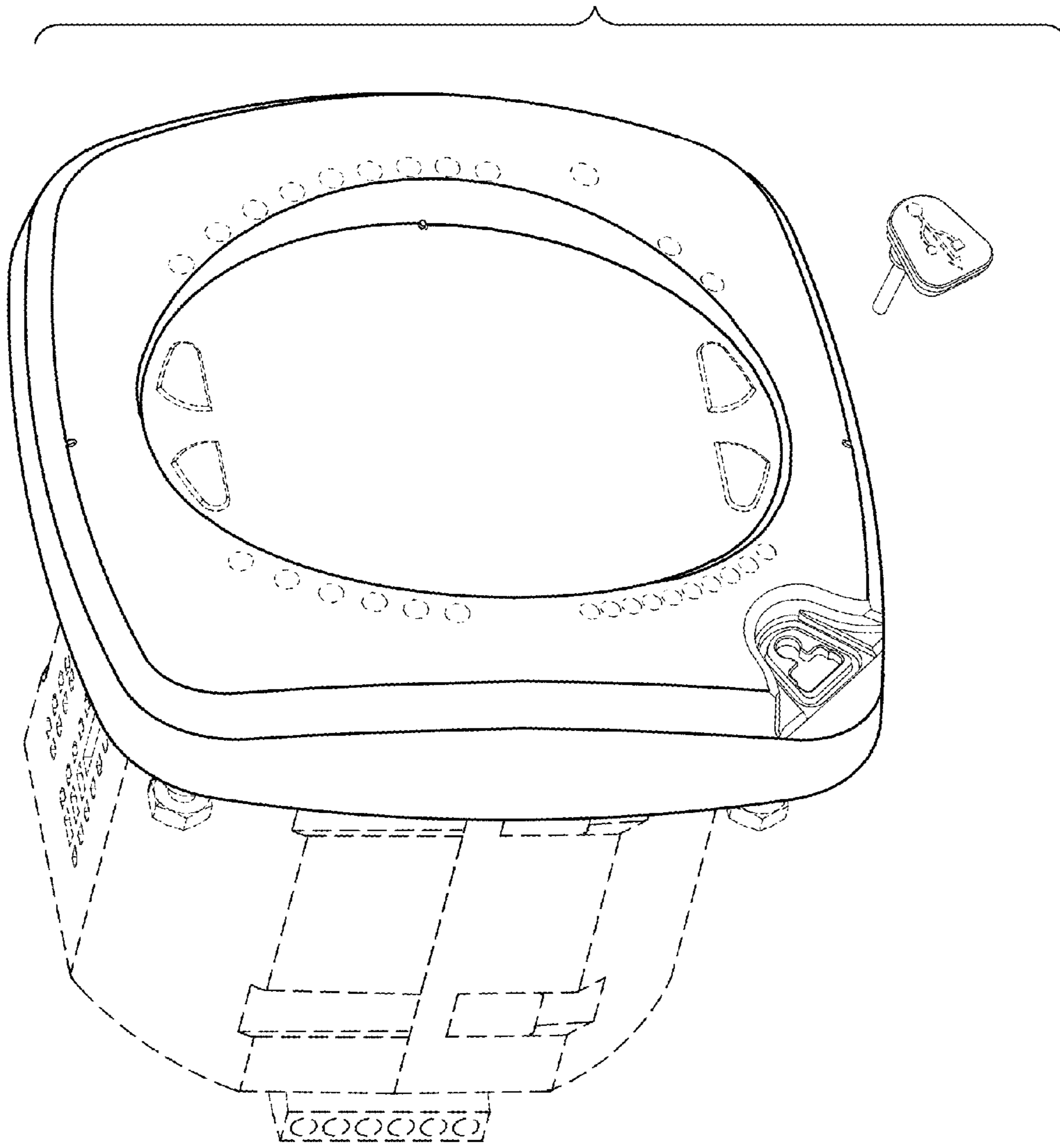

FIG.28

FIG. 29



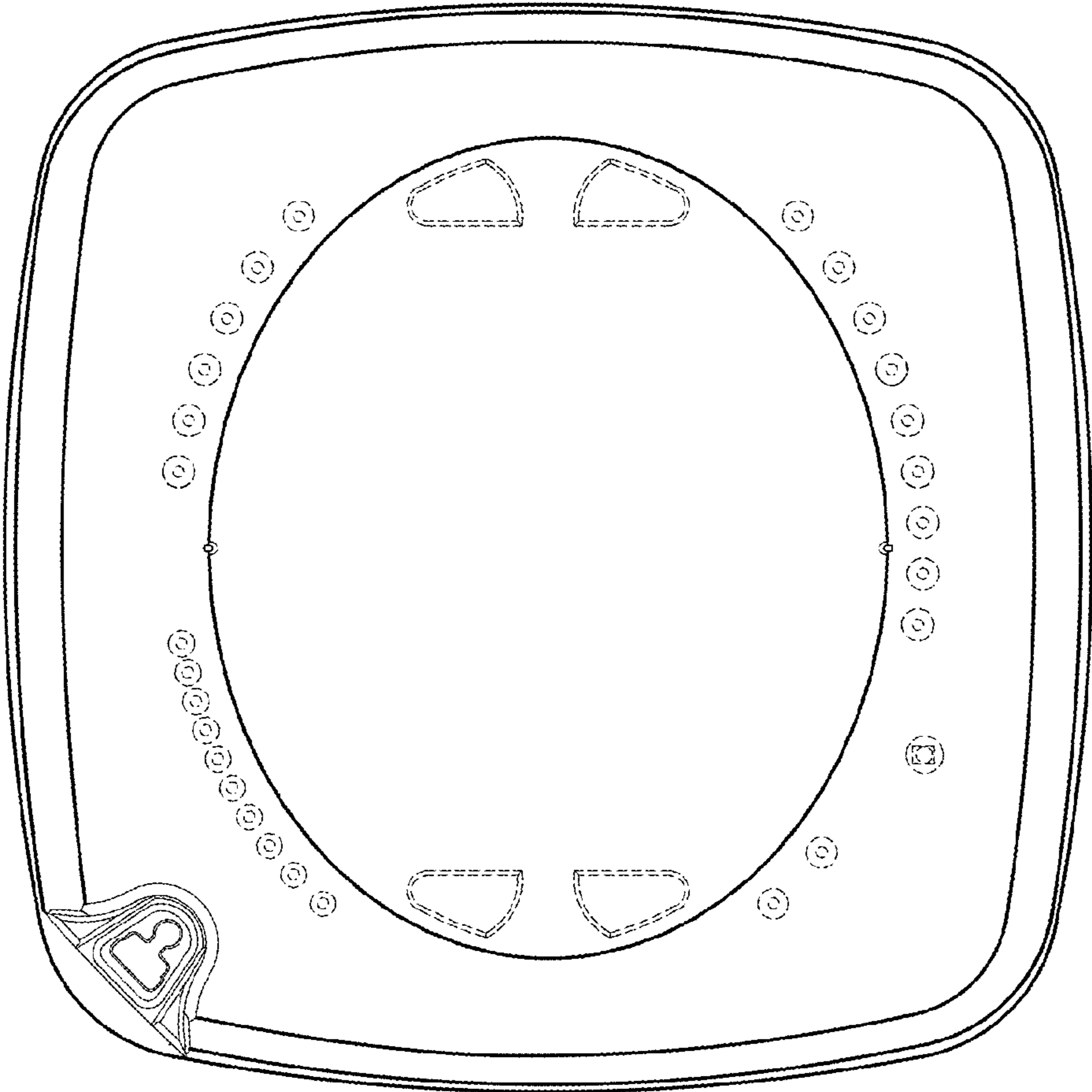

FIG.30

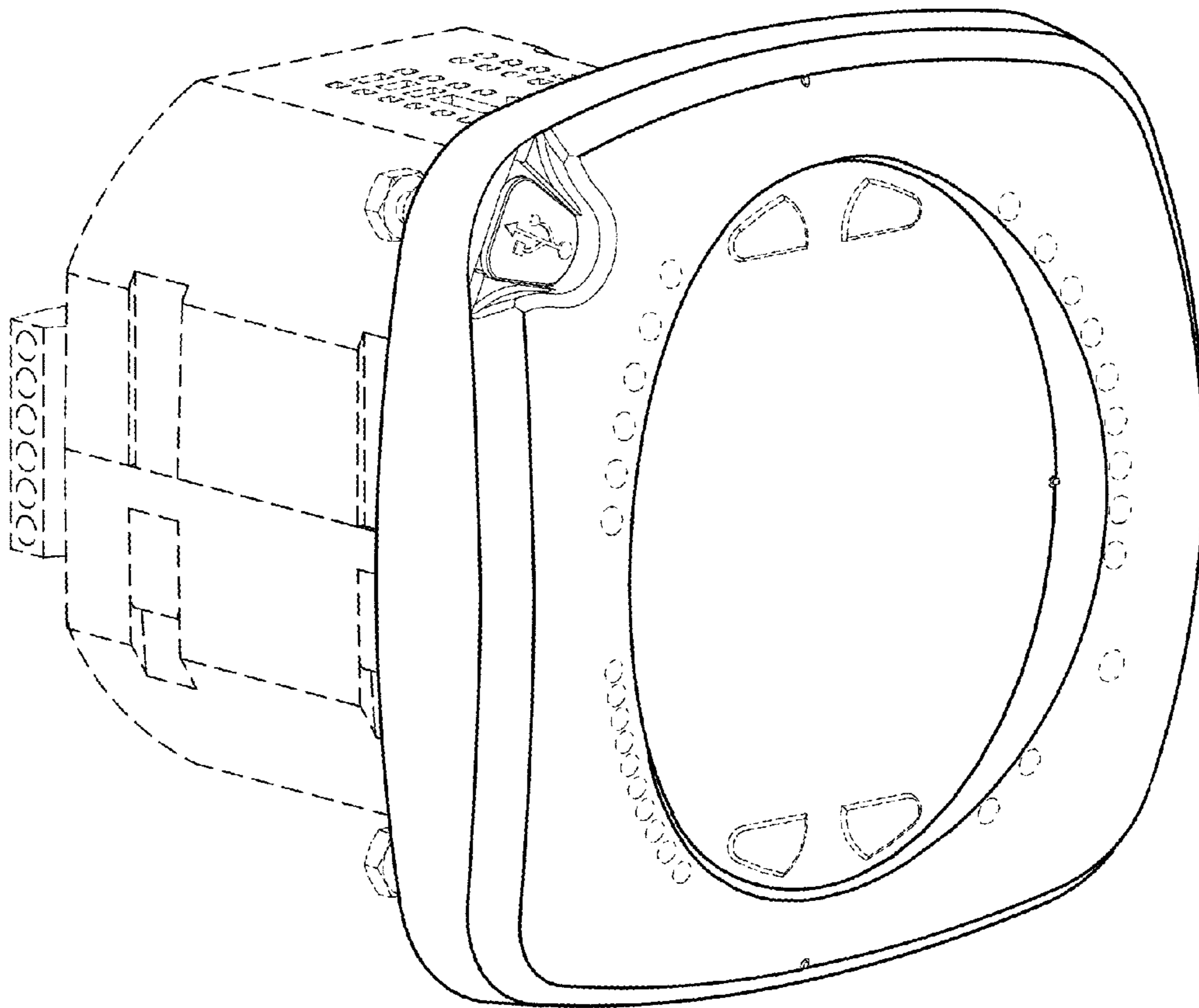

FIG.31

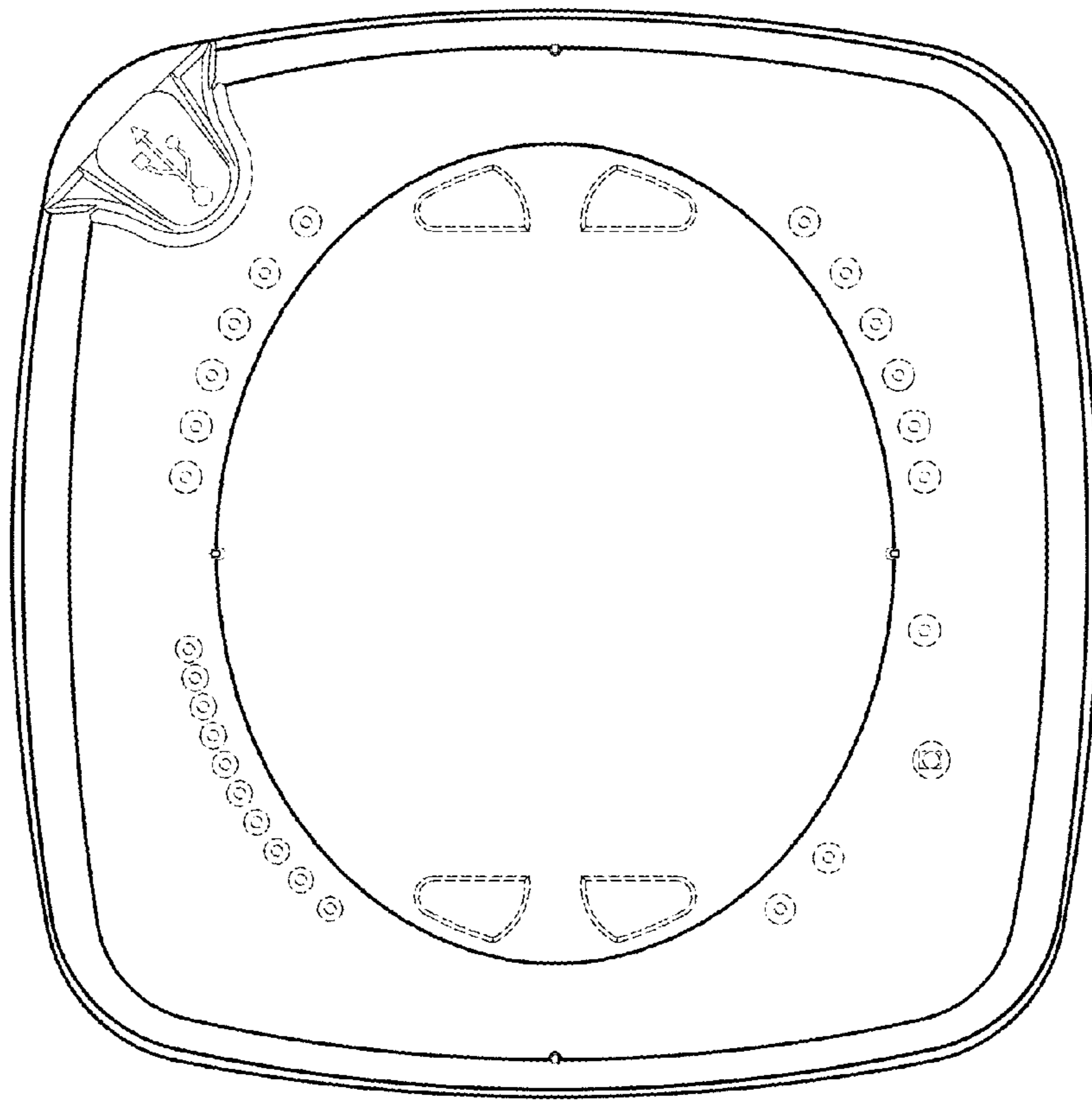

FIG.32

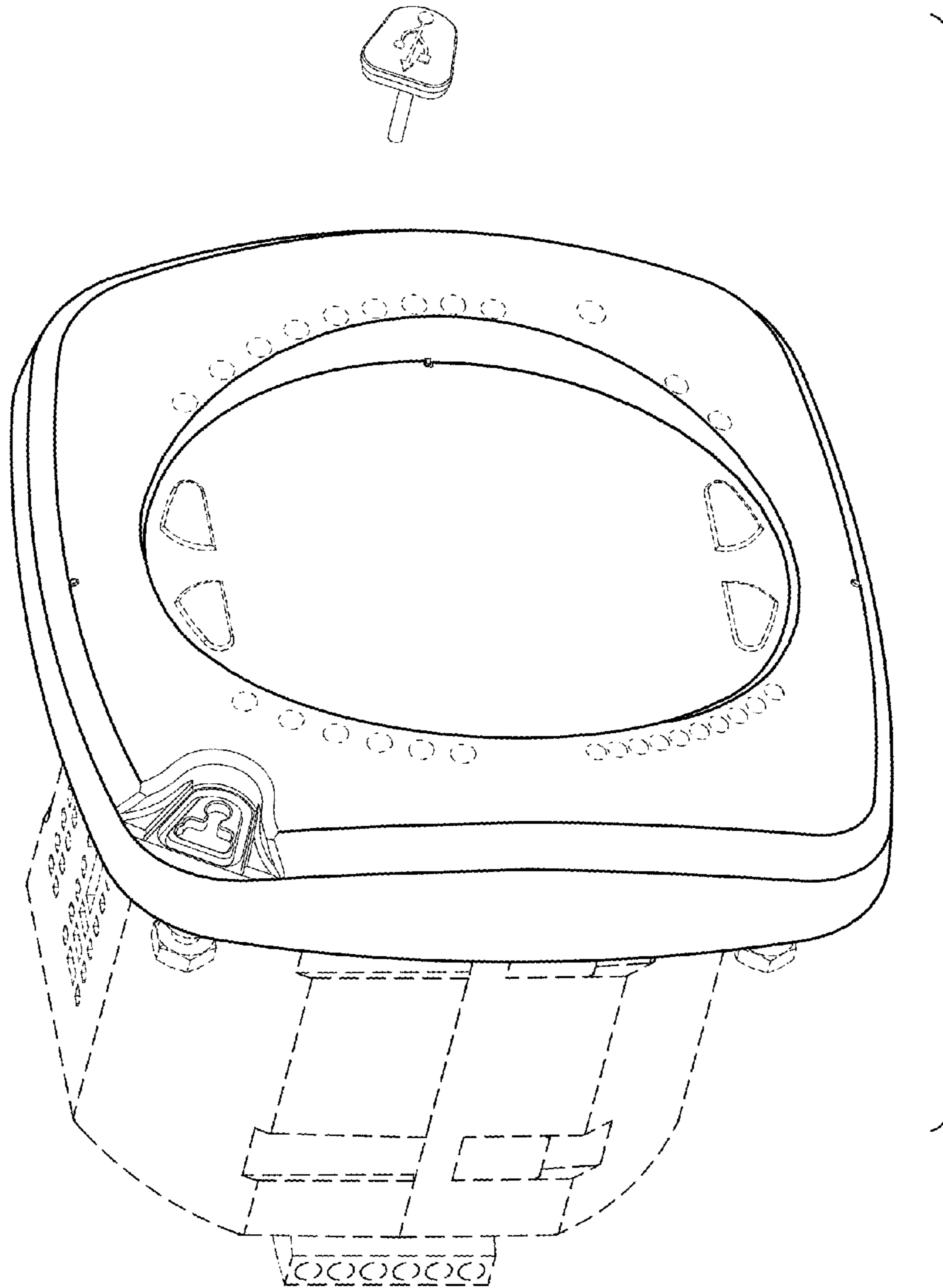

FIG. 33

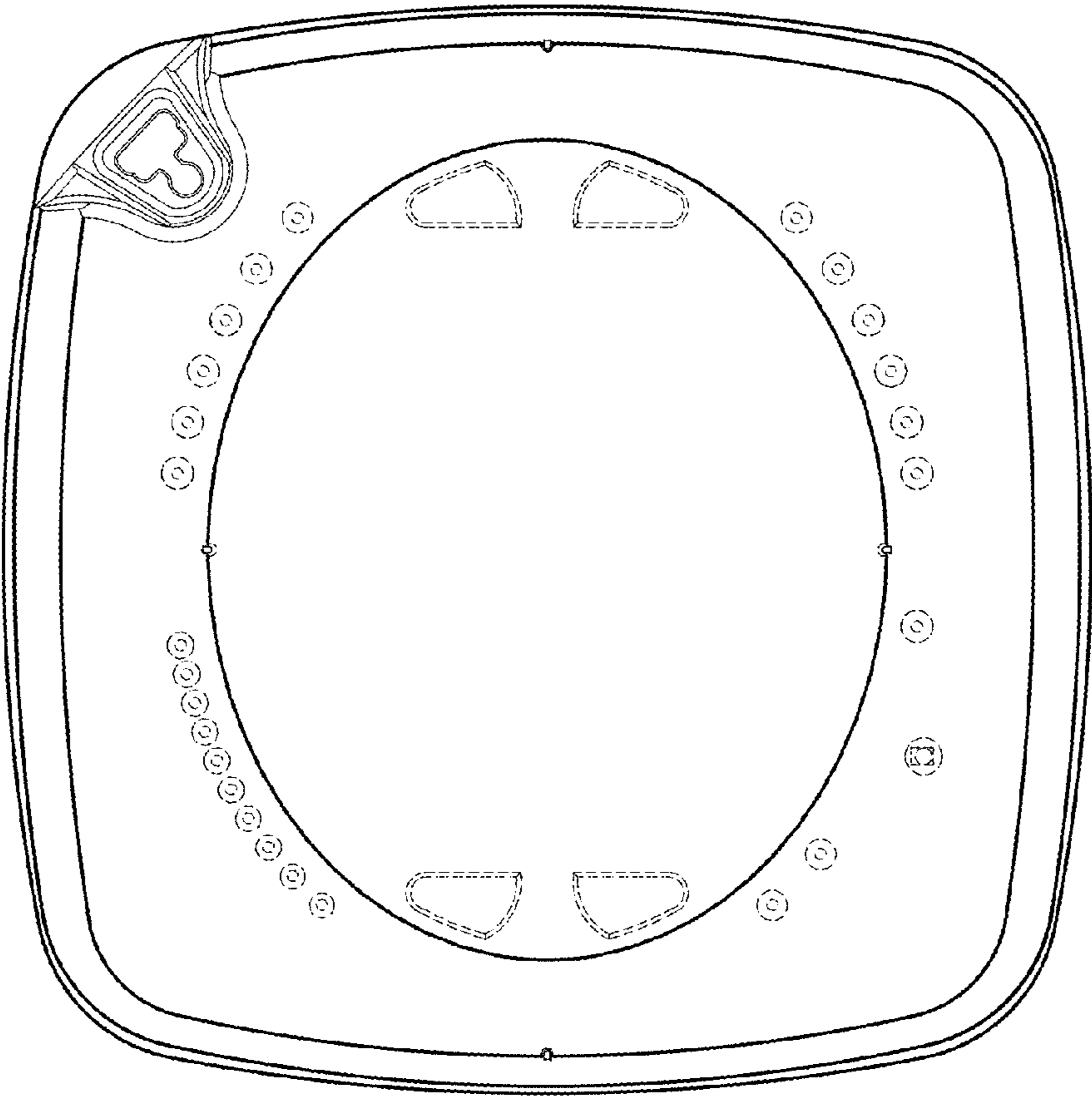

FIG.34

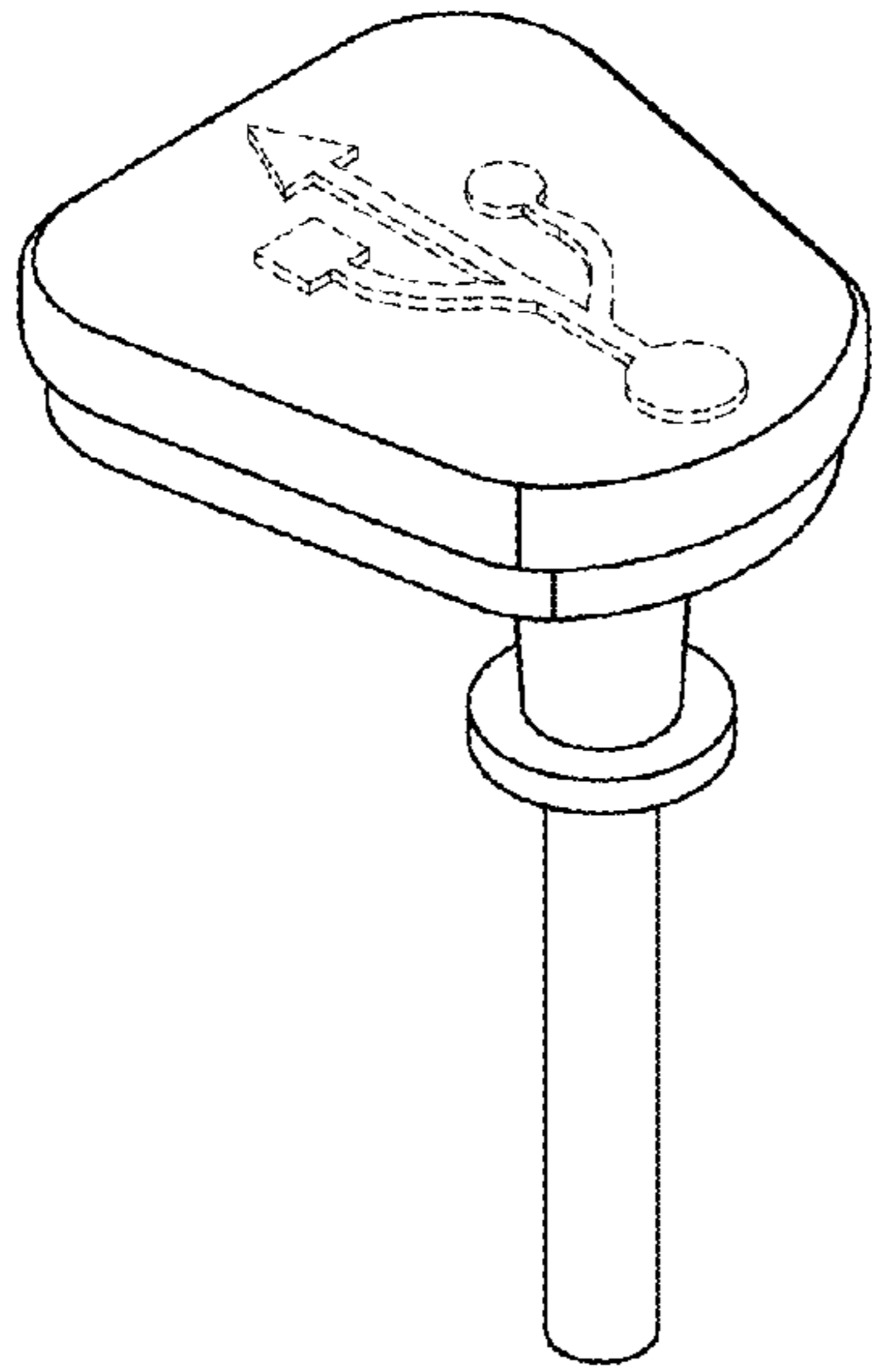

FIG. 35

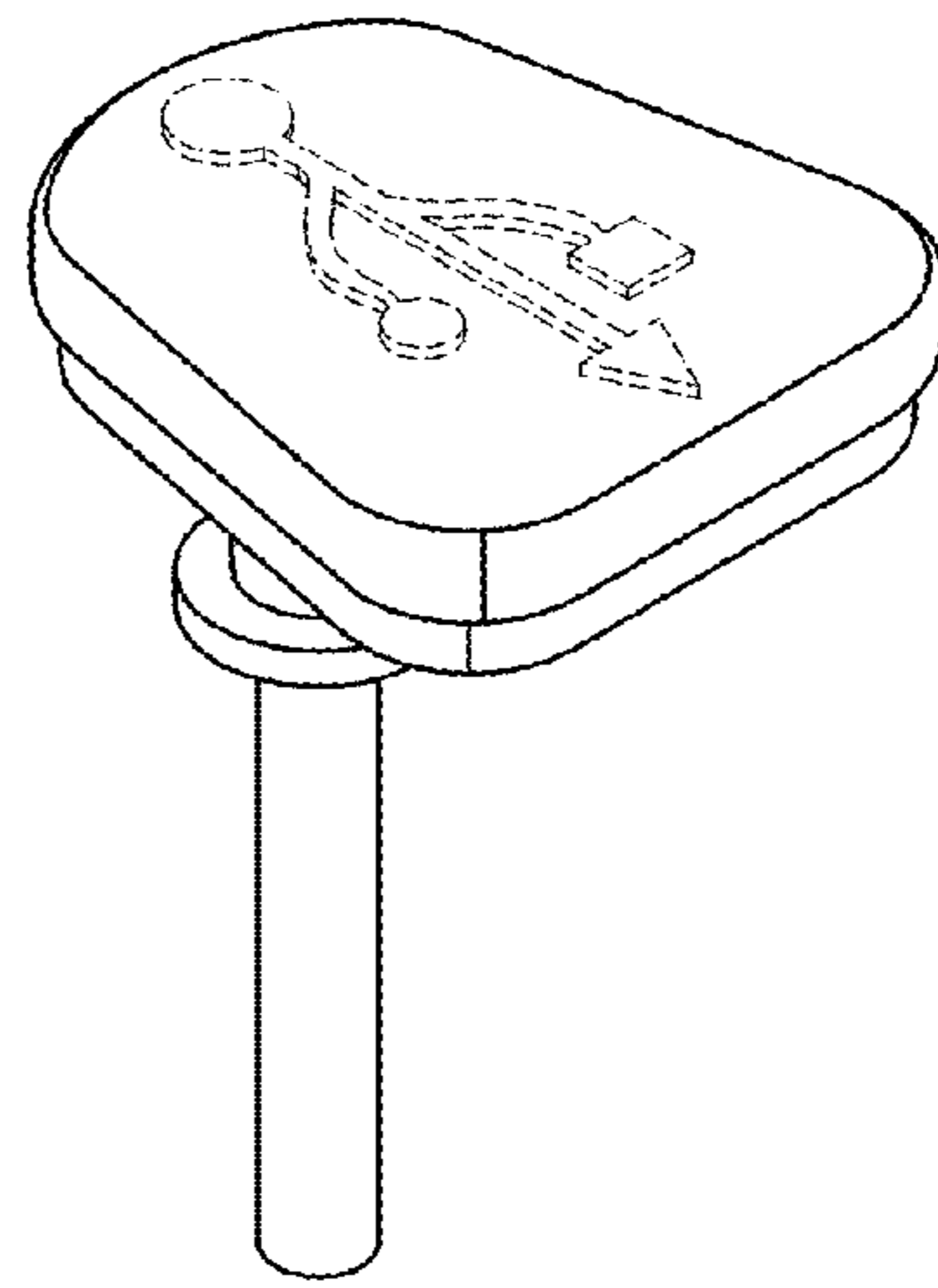

FIG. 36

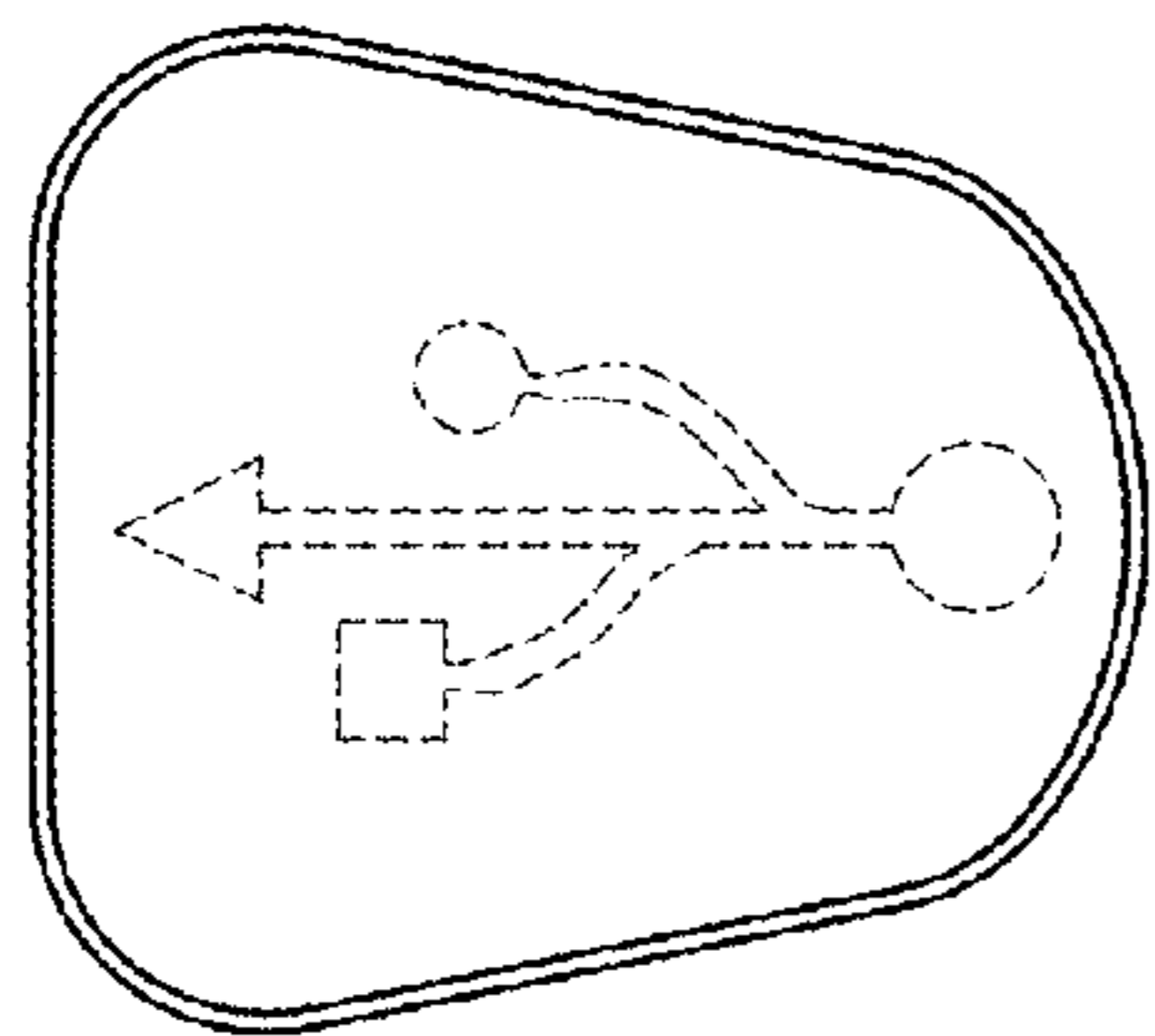

FIG. 37

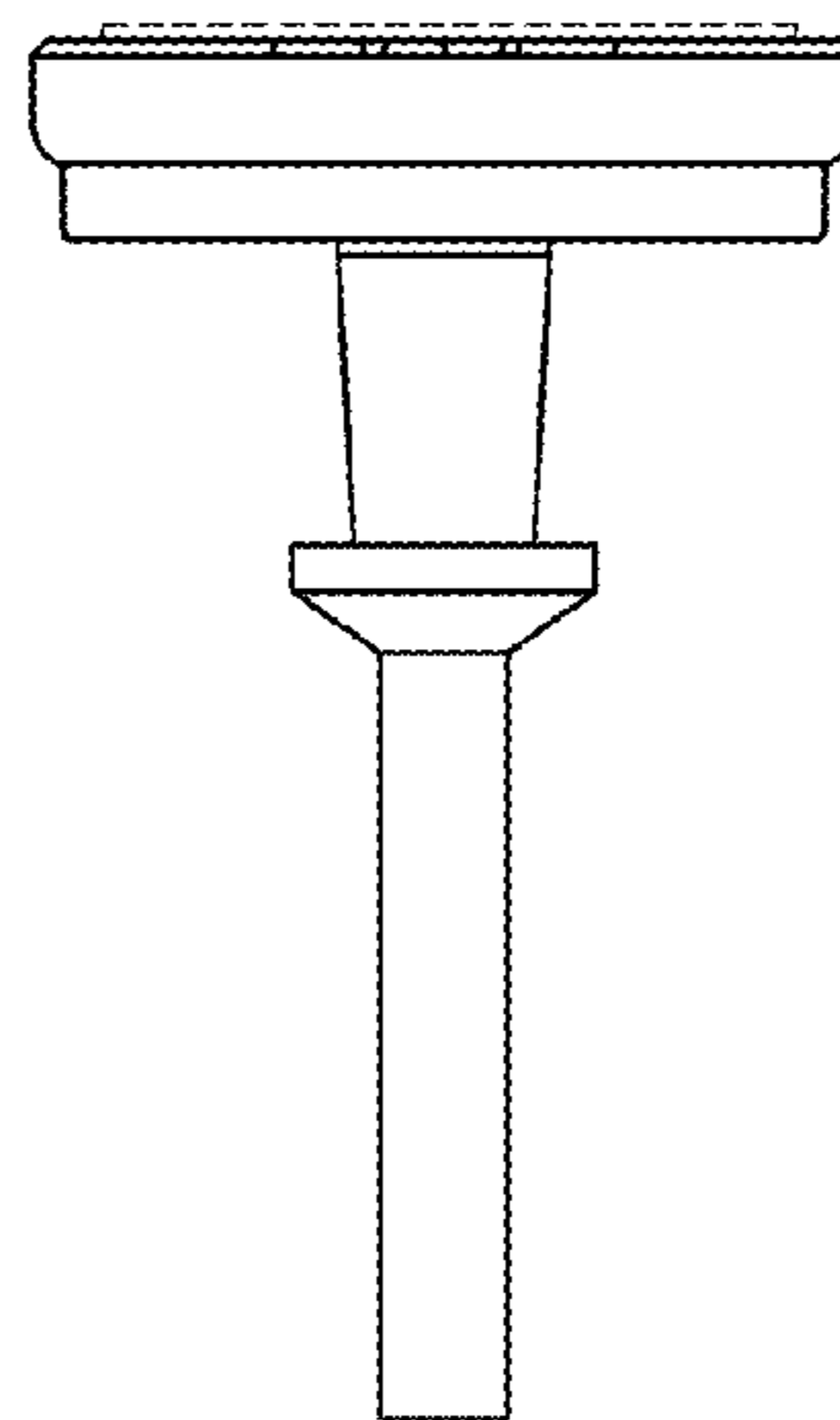

FIG. 38

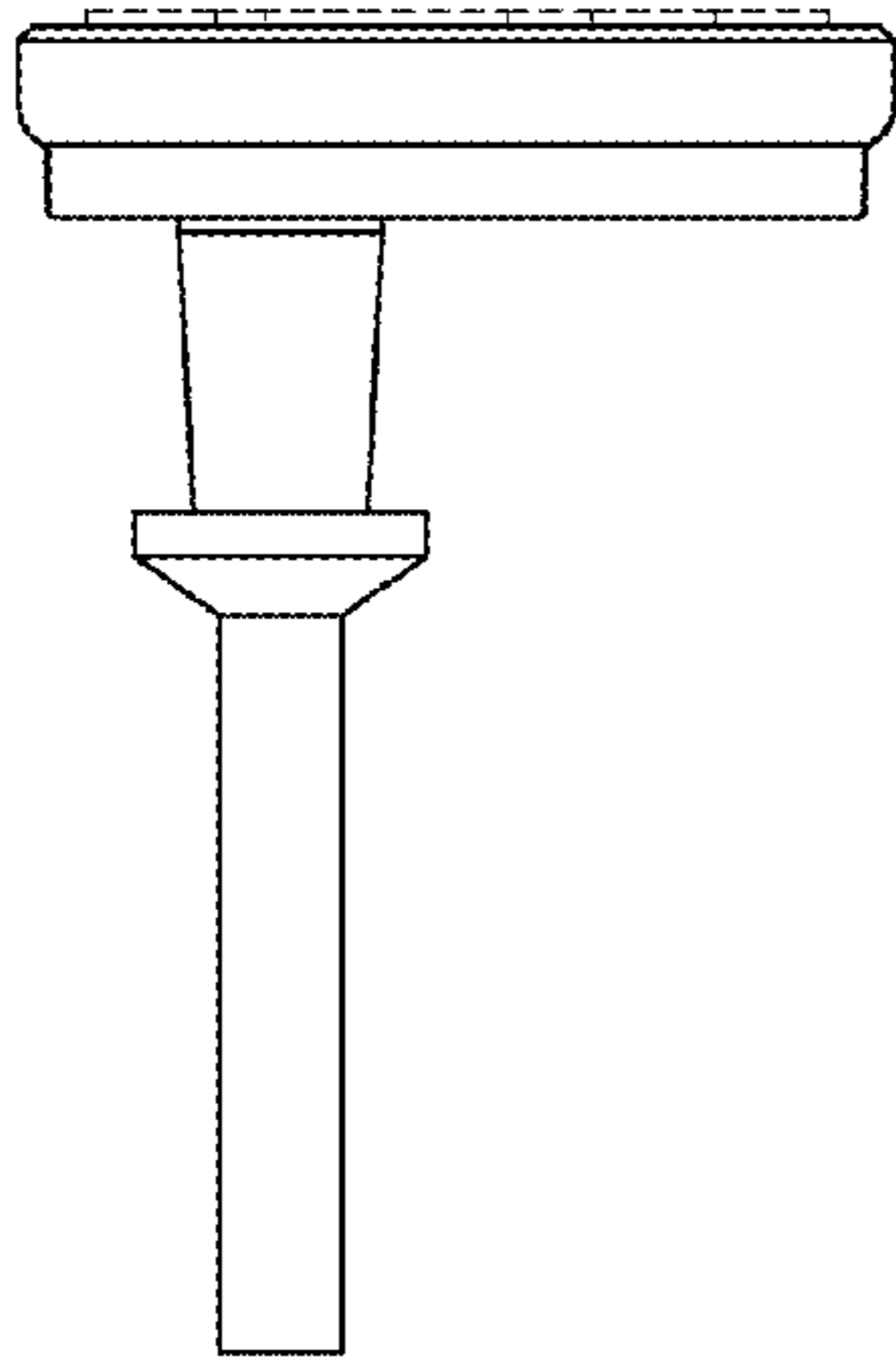

FIG.39

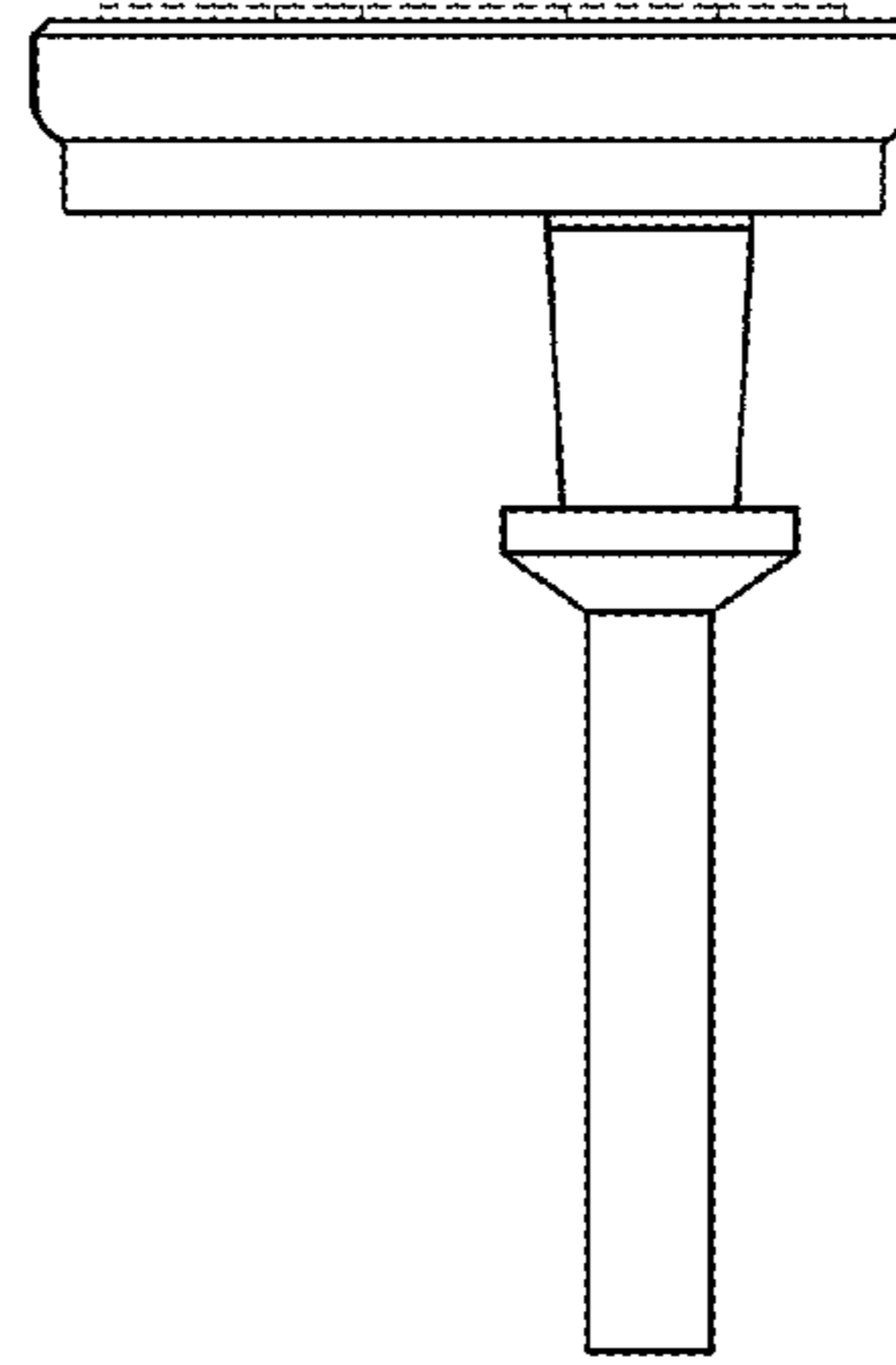

FIG.40

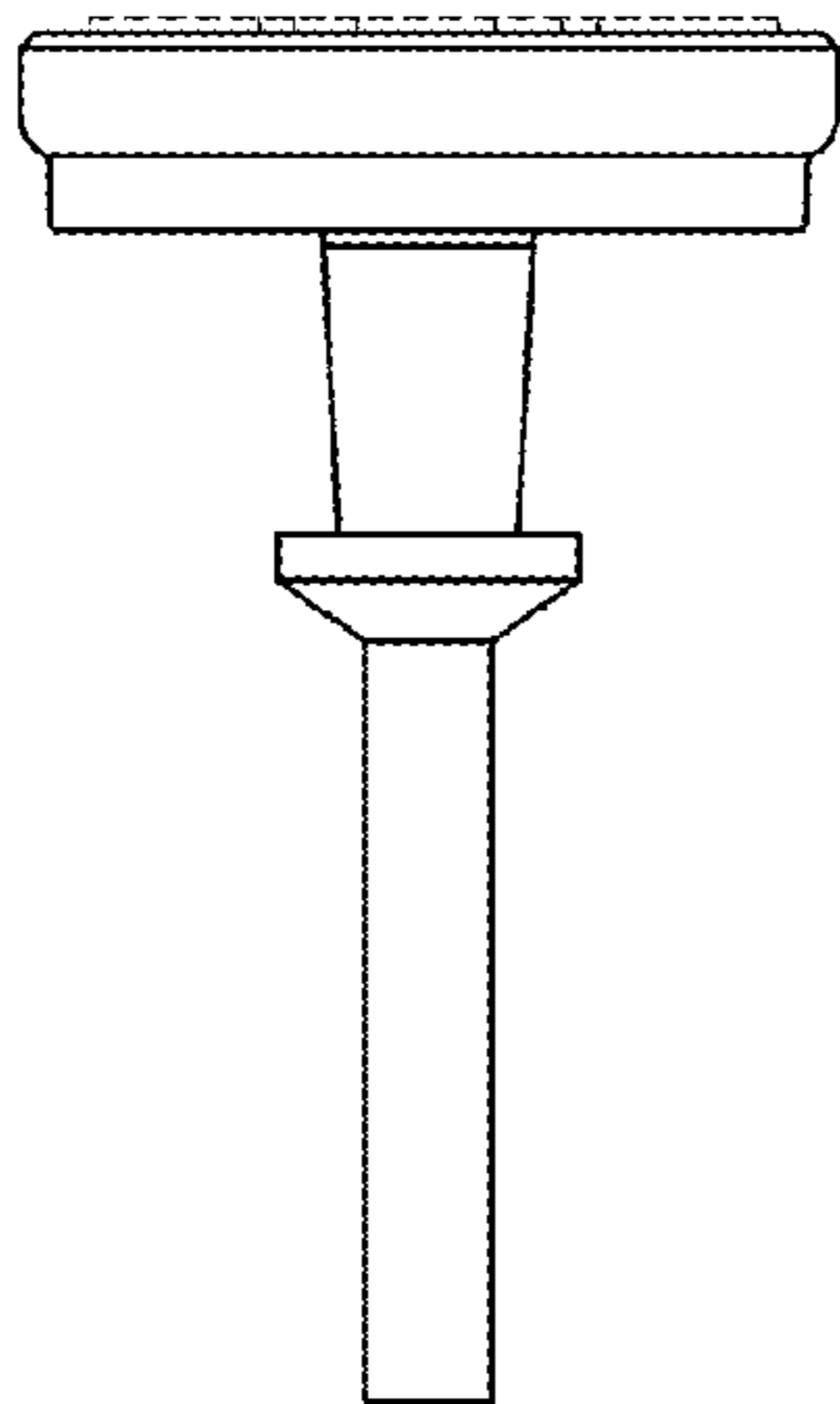

FIG.41

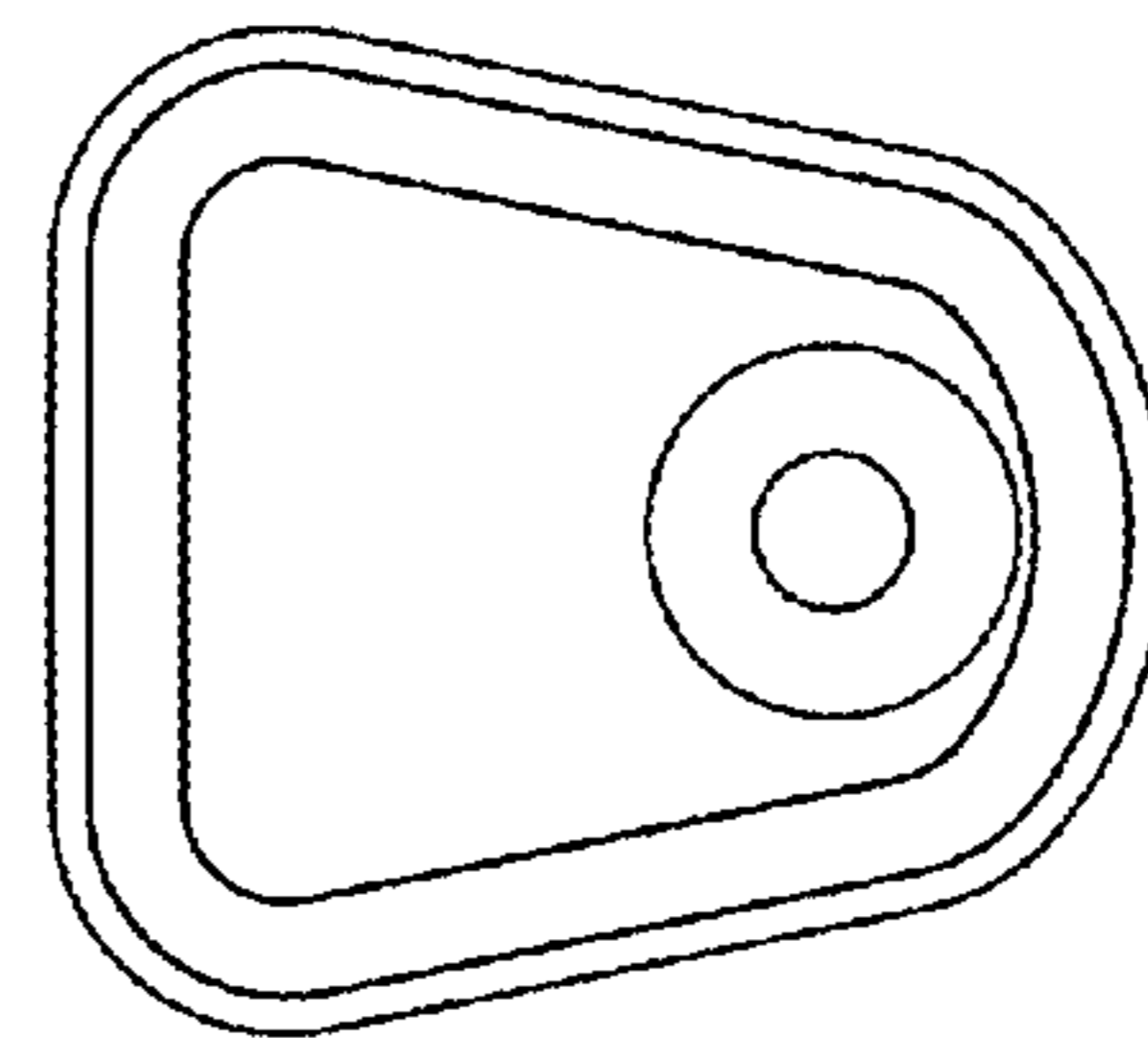

FIG.42