



US00D711780S

(12) **United States Design Patent**  
**Badstuebner et al.**

(10) **Patent No.:** **US D711,780 S**

(45) **Date of Patent:** **\*\* Aug. 26, 2014**

(54) **VEHICLE**

(75) Inventors: **Achim Badstuebner**, Munich (DE);  
**Dany Garand**, Ingolstadt (DE); **Juergen Loeffler**, Gaimersheim (DE)

(73) Assignee: **Audi AG**, Ingolstadt (DE)

(\*\*) Term: **14 Years**

(21) Appl. No.: **29/420,660**

(22) Filed: **May 11, 2012**

(30) **Foreign Application Priority Data**

Nov. 11, 2011 (EM) ..... 001 946 062-0001

(51) **LOC (10) Cl.** ..... **12-08**

(52) **U.S. Cl.**  
USPC ..... **D12/91**

(58) **Field of Classification Search**  
USPC ..... D12/86, 88, 90, 91, 92; D21/424, 433,  
D21/434; 296/181.1, 181.5  
See application file for complete search history.

(56) **References Cited**

**U.S. PATENT DOCUMENTS**

D520,910 S \* 5/2006 Nordmann ..... D12/91  
D553,050 S \* 10/2007 Barrington et al. .... D12/91  
D558,094 S \* 12/2007 Pfeiffer ..... D12/91  
D584,658 S \* 1/2009 Minami ..... D12/91  
D592,550 S \* 5/2009 Lawlis ..... D12/91

D592,552 S \* 5/2009 Wang et al. .... D12/91  
D599,704 S \* 9/2009 Frenzel et al. .... D12/91  
D601,924 S \* 10/2009 Bauer et al. .... D12/91  
D609,135 S \* 2/2010 Kim ..... D12/91  
D617,682 S \* 6/2010 Frei et al. .... D12/91  
D619,500 S \* 7/2010 Hsu et al. .... D12/91  
D621,747 S \* 8/2010 Huet ..... D12/91  
D634,243 S \* 3/2011 Frei et al. .... D12/91

\* cited by examiner

*Primary Examiner* — Philip S Hyder

*Assistant Examiner* — Darlington Ly

(74) *Attorney, Agent, or Firm* — Lucas & Mercanti, LLP;  
Klaus P. Stoffel

(57) **CLAIM**

The ornamental design for a vehicle, as shown and described.

**DESCRIPTION**

FIG. 1 is a front, left side perspective view of the vehicle of the present invention;  
FIG. 2 is a left side elevation view thereof;  
FIG. 3 is a right side elevation view thereof;  
FIG. 4 is a top plan view thereof;  
FIG. 5 is a rear elevation view thereof; and,  
FIG. 6 is a front elevation view thereof.

The uniformly broken lines shown in the drawings illustrate portions of the vehicle that form no part of the claimed design. The dash-dot broken lines represent boundaries of the claimed design and form no part thereof.

**1 Claim, 6 Drawing Sheets**

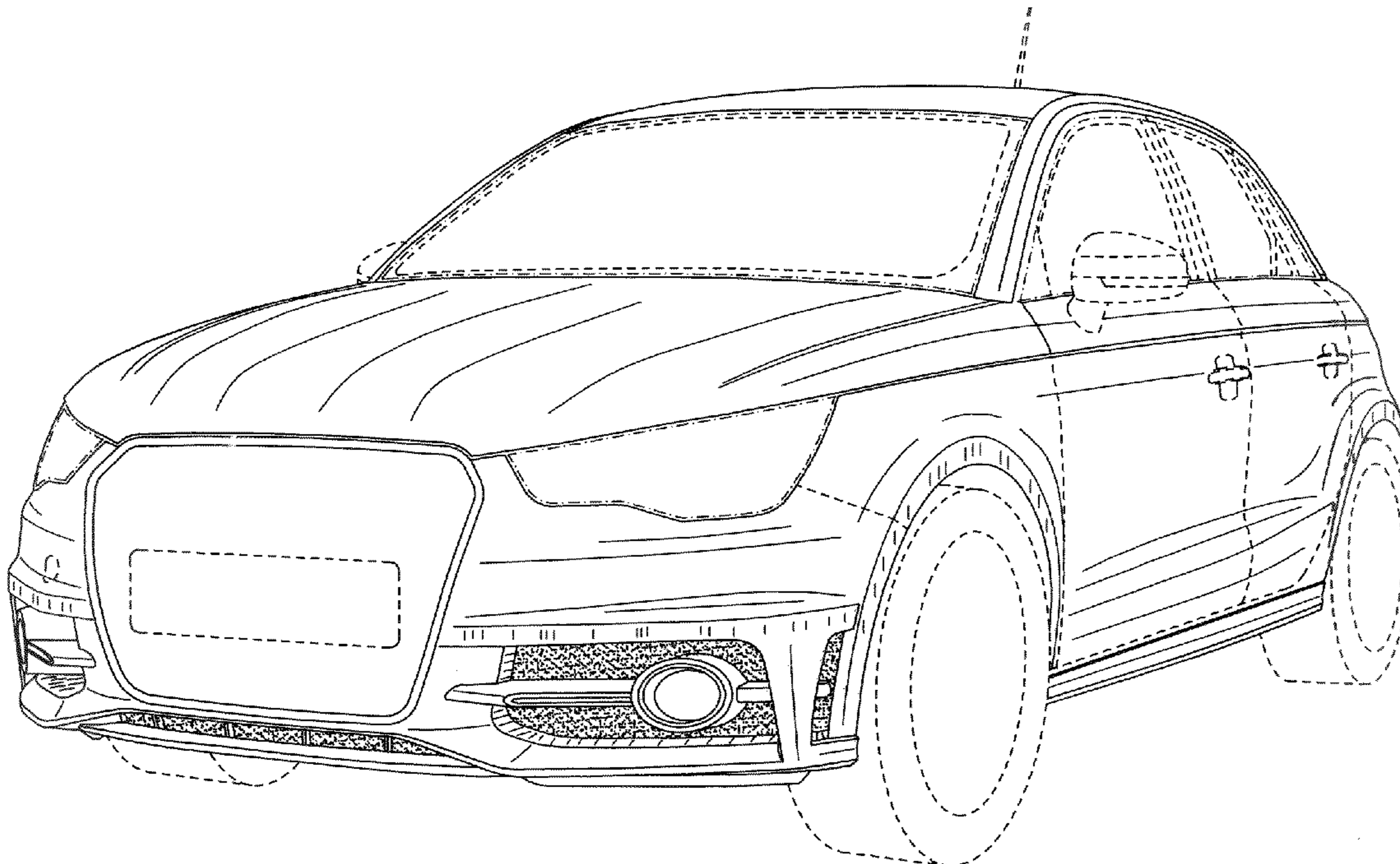

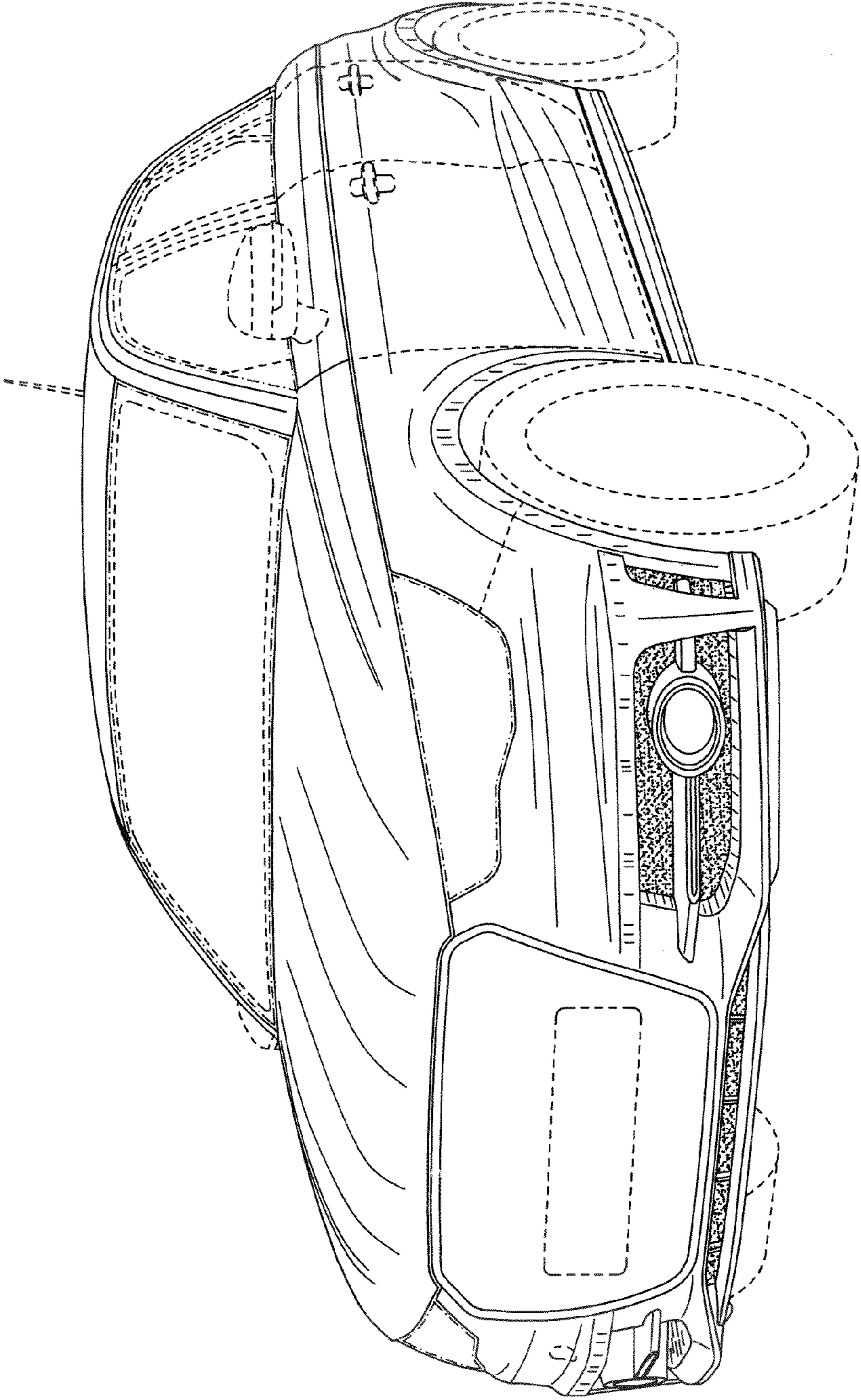

FIG. 1

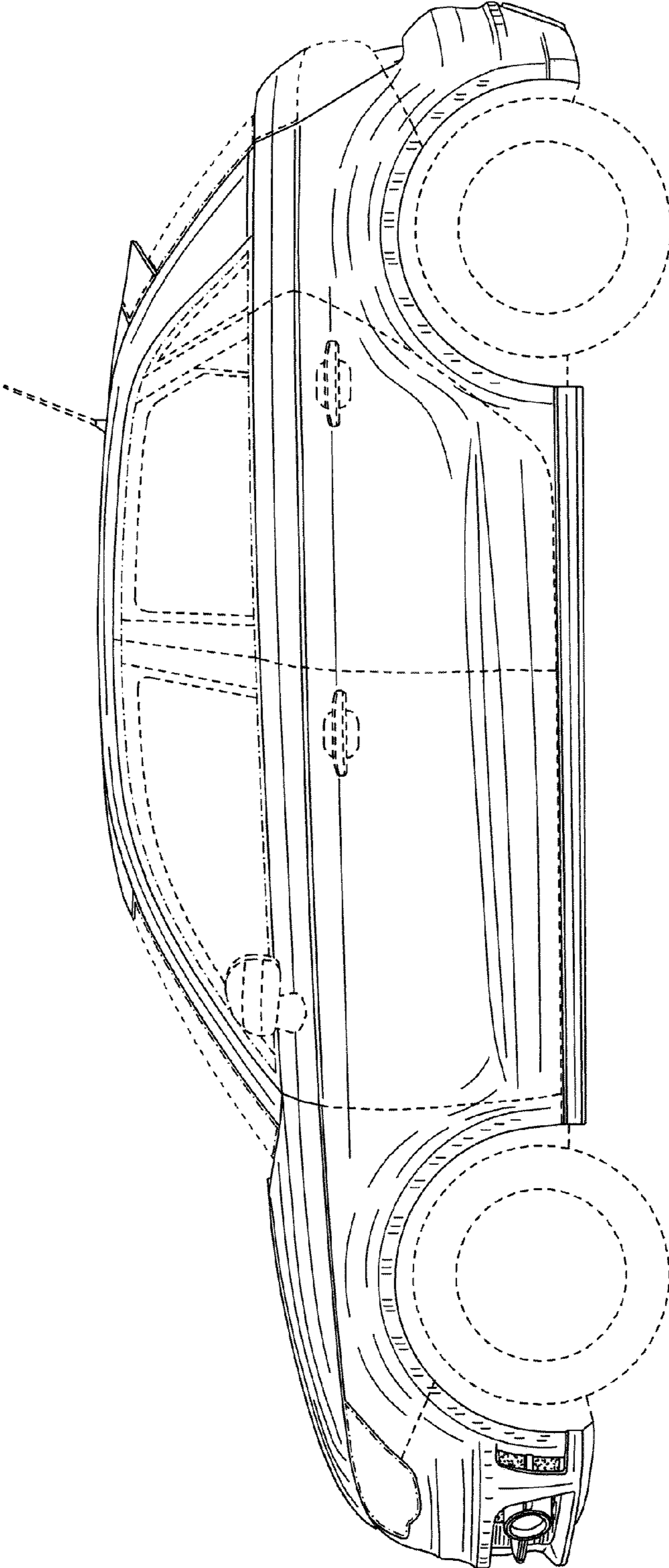

FIG. 2

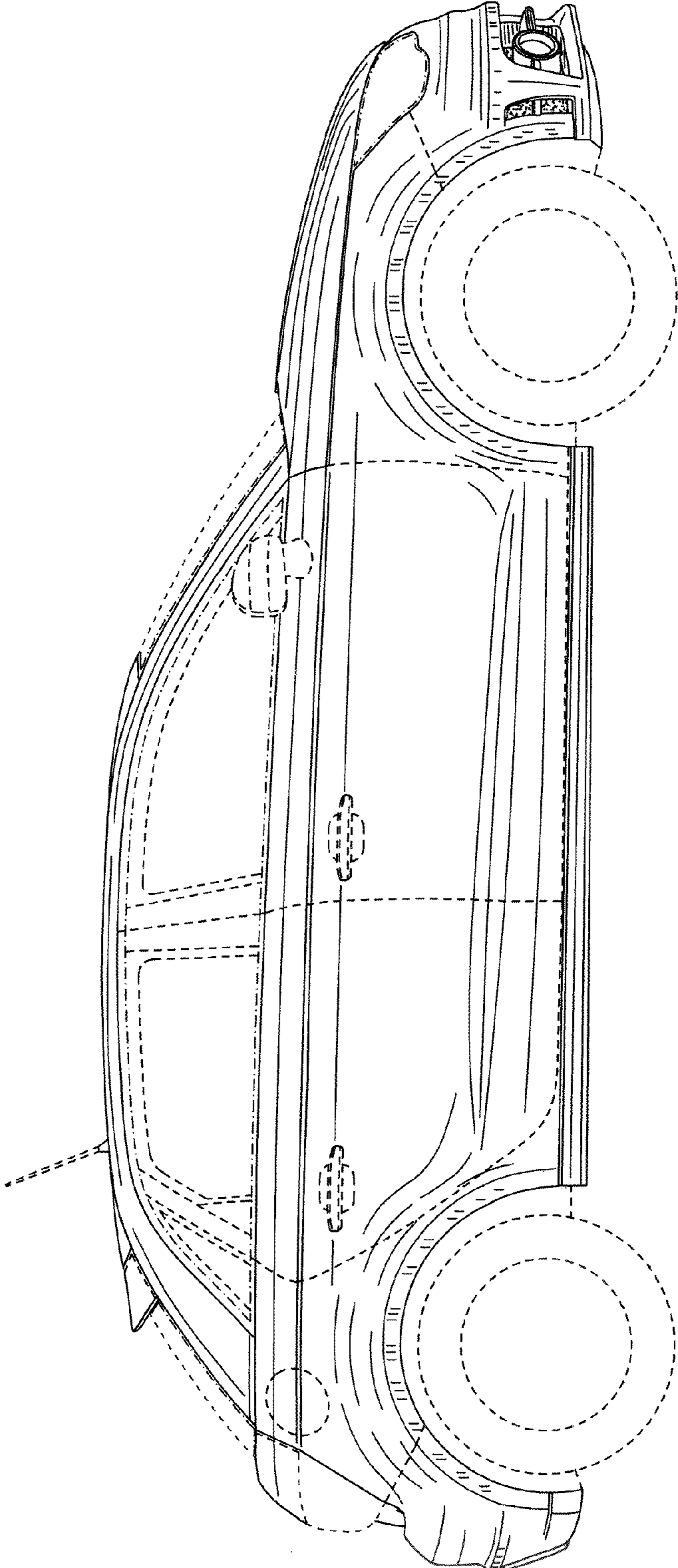

FIG. 3

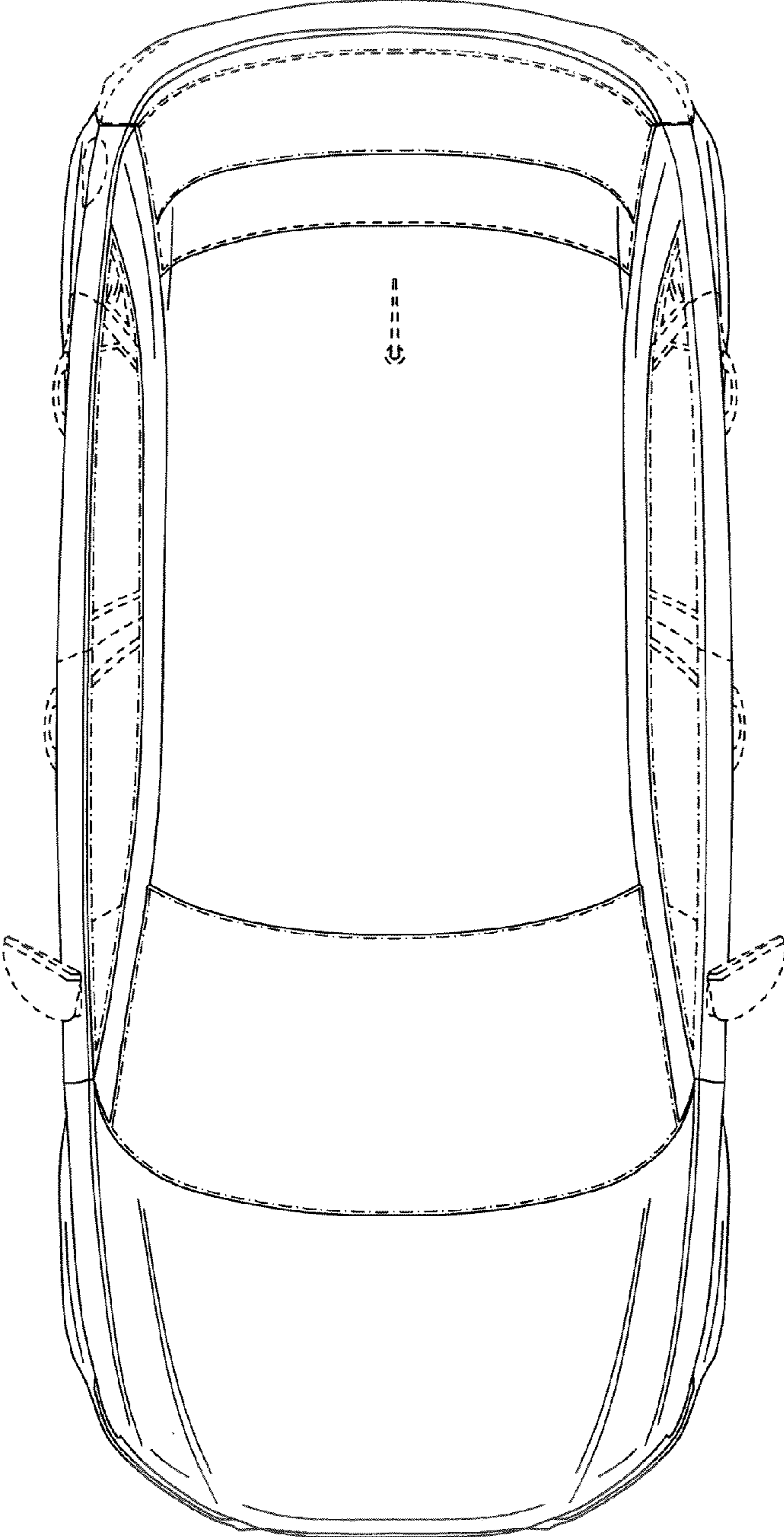

FIG. 4

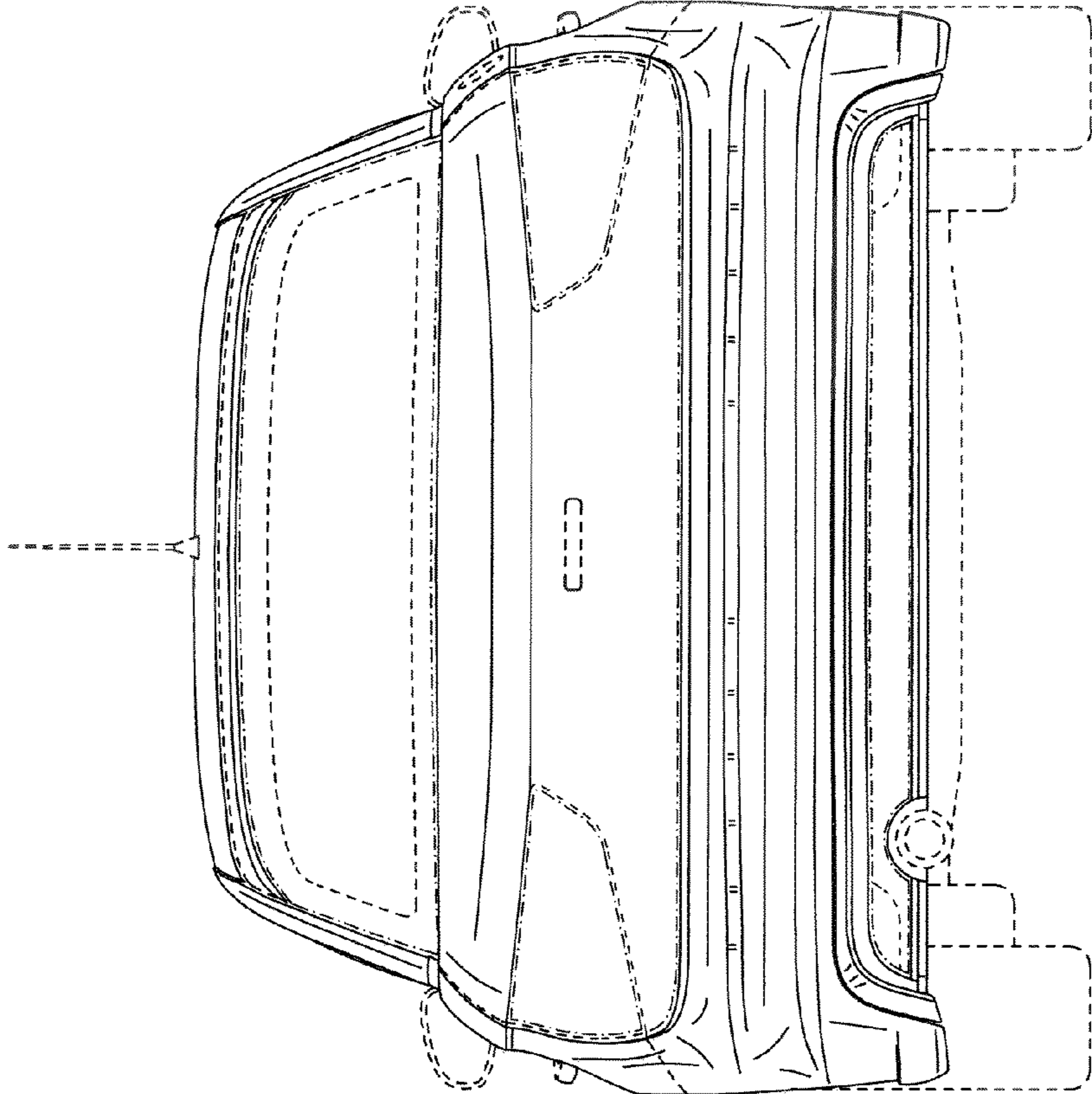

FIG. 5

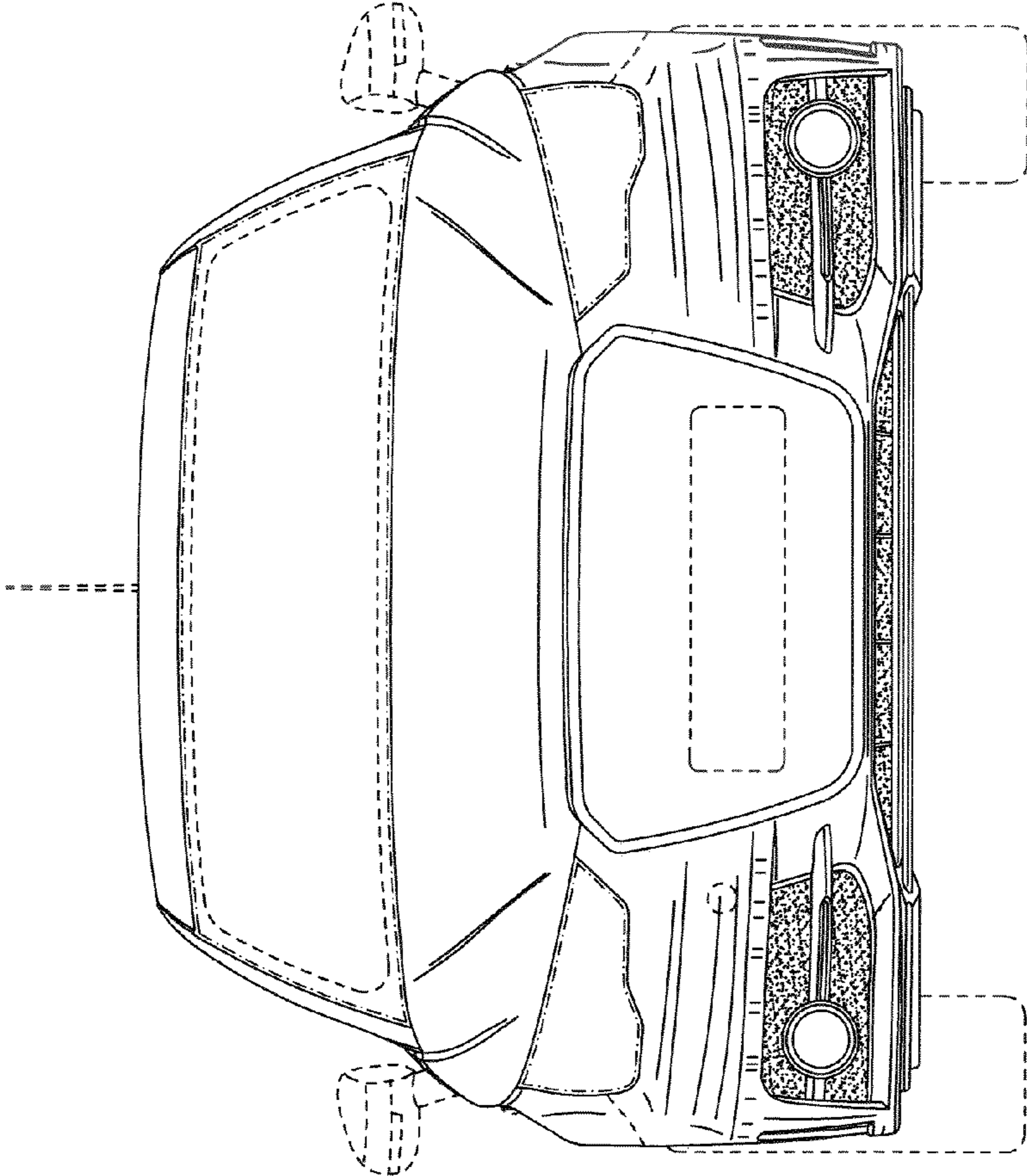

FIG. 6