



US00D711779S

(12) **United States Design Patent**
Badstuebner et al.

(10) **Patent No.:** **US D711,779 S**

(45) **Date of Patent:** **** Aug. 26, 2014**

(54) **VEHICLE**

(75) Inventors: **Achim Badstuebner**, Munich (DE);
Dany Garand, Ingolstadt (DE); **Juergen Loeffler**, Gaimersheim (DE)

(73) Assignee: **Audi AG**, Ingolstadt (DE)

(**) Term: **14 Years**

(21) Appl. No.: **29/420,657**

(22) Filed: **May 11, 2012**

(30) **Foreign Application Priority Data**

Nov. 11, 2011 (EM) 001 946 039-0001

(51) **LOC (10) Cl.** **12-08**

(52) **U.S. Cl.**
USPC **D12/91**

(58) **Field of Classification Search**
USPC D12/86, 88, 90, 91, 92; D21/424, 433,
D21/434; 296/181.1, 181.5
See application file for complete search history.

(56) **References Cited**

U.S. PATENT DOCUMENTS

D520,910 S * 5/2006 Nordmann D12/91
D553,050 S * 10/2007 Barrington et al. D12/91
D558,094 S * 12/2007 Pfeiffer D12/91
D584,658 S * 1/2009 Minami D12/91
D592,550 S * 5/2009 Lawlis D12/91

D592,552 S * 5/2009 Wang et al. D12/91
D599,704 S * 9/2009 Frenzel et al. D12/91
D601,924 S * 10/2009 Bauer et al. D12/91
D609,135 S * 2/2010 Kim D12/91
D617,682 S * 6/2010 Frei et al. D12/91
D619,500 S * 7/2010 Hsu et al. D12/91
D621,747 S * 8/2010 Huet D12/91
D634,243 S * 3/2011 Frei et al. D12/91

* cited by examiner

Primary Examiner — Philip S Hyder

Assistant Examiner — Darlington Ly

(74) *Attorney, Agent, or Firm* — Lucas & Merchanti, LLP;
Klaus P. Stoffel

(57) **CLAIM**

The ornamental design for a vehicle, as shown and described.

DESCRIPTION

FIG. 1 is a front, left side perspective view of the vehicle of the present invention;

FIG. 2 is a left side elevation view thereof;

FIG. 3 is a right side elevation view thereof;

FIG. 4 is a top plan view thereof;

FIG. 5 is a rear elevation view thereof;

FIG. 6 is a front elevation view thereof; and,

FIG. 7 is a rear, left side perspective view thereof.

The uniformly even broken lines shown in the drawings illustrate portions of the vehicle that form no part of the claimed design. The dash-dot broken lines represent boundaries of the claimed design and form no part thereof.

1 Claim, 7 Drawing Sheets

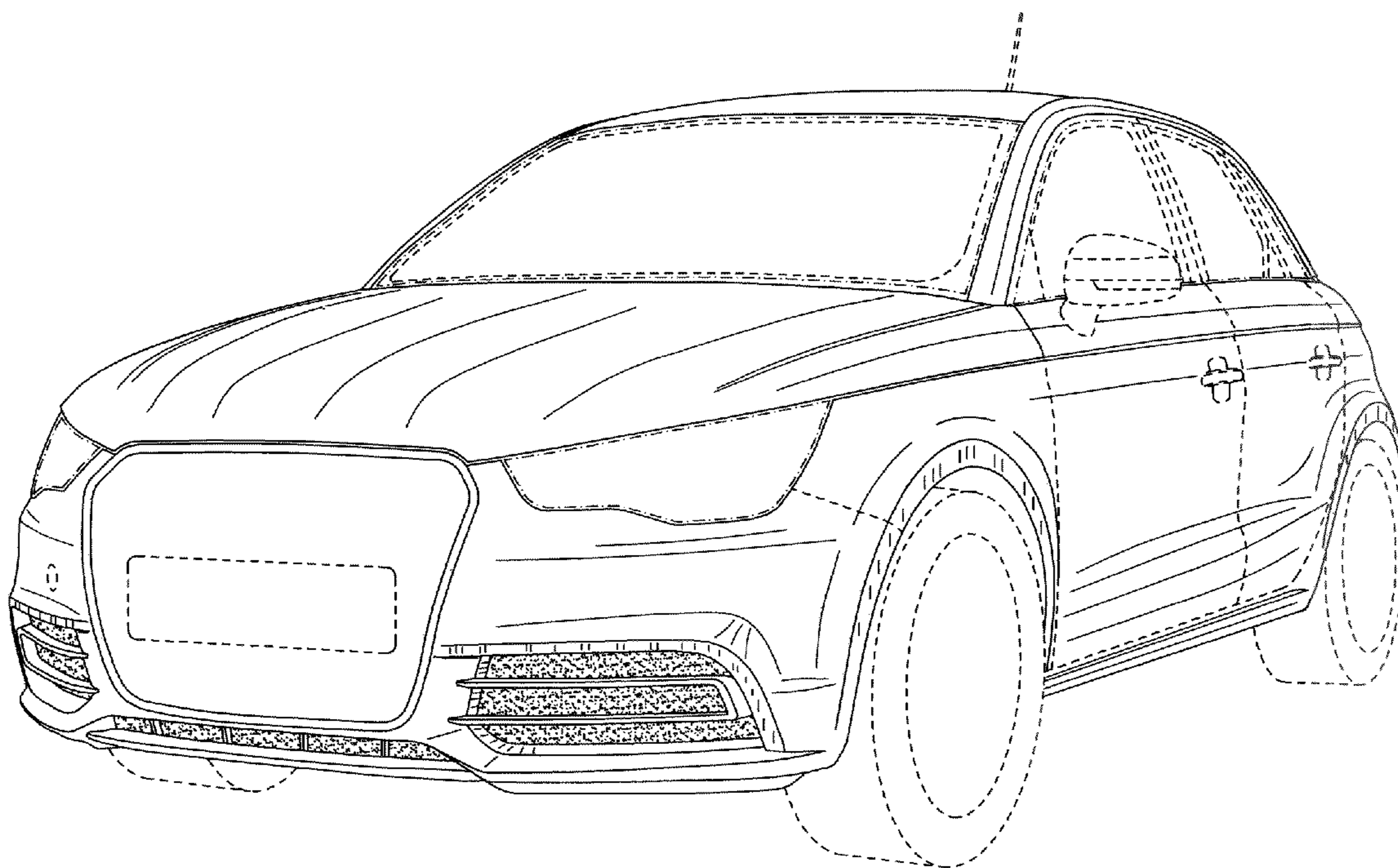

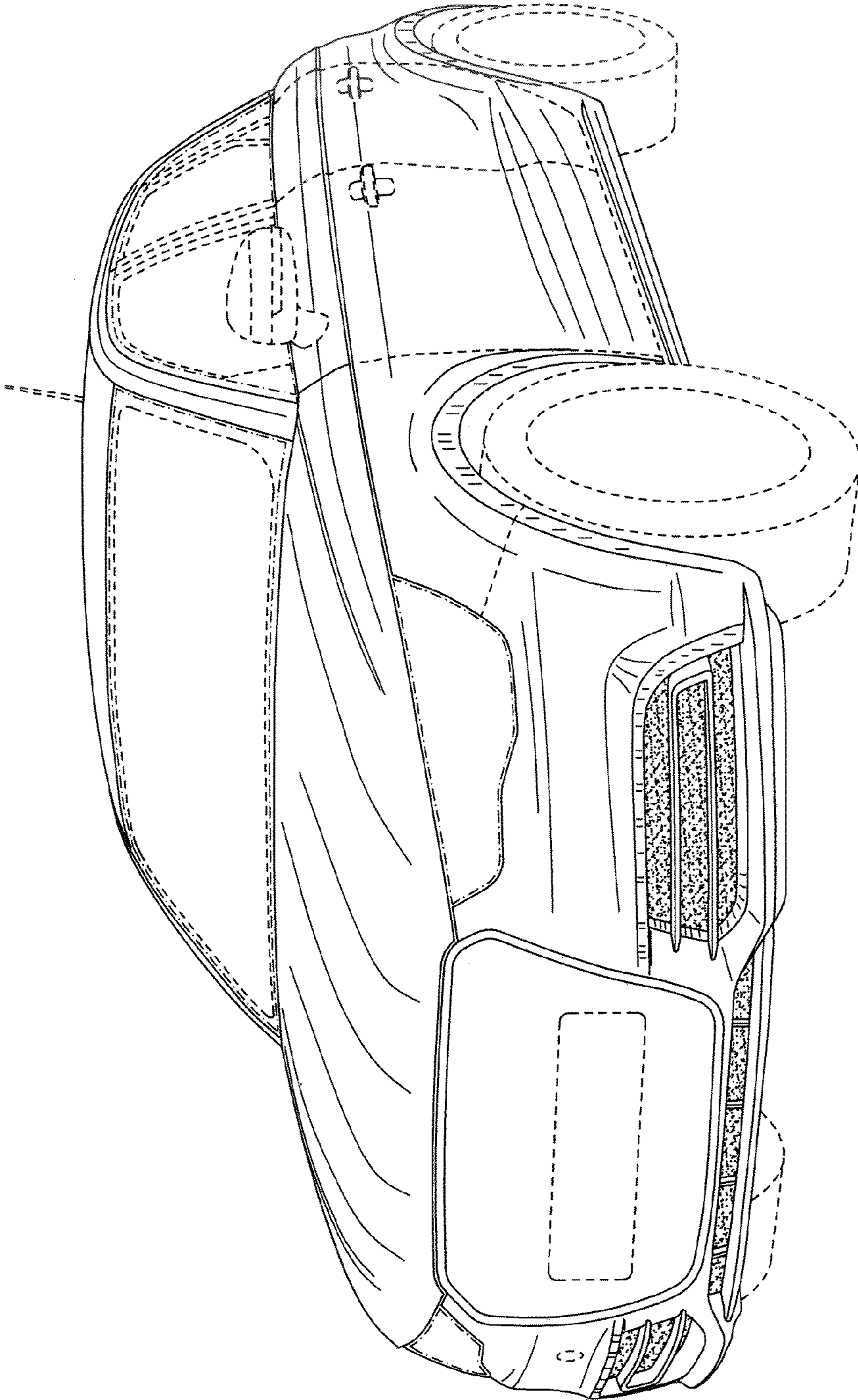

FIG. 1

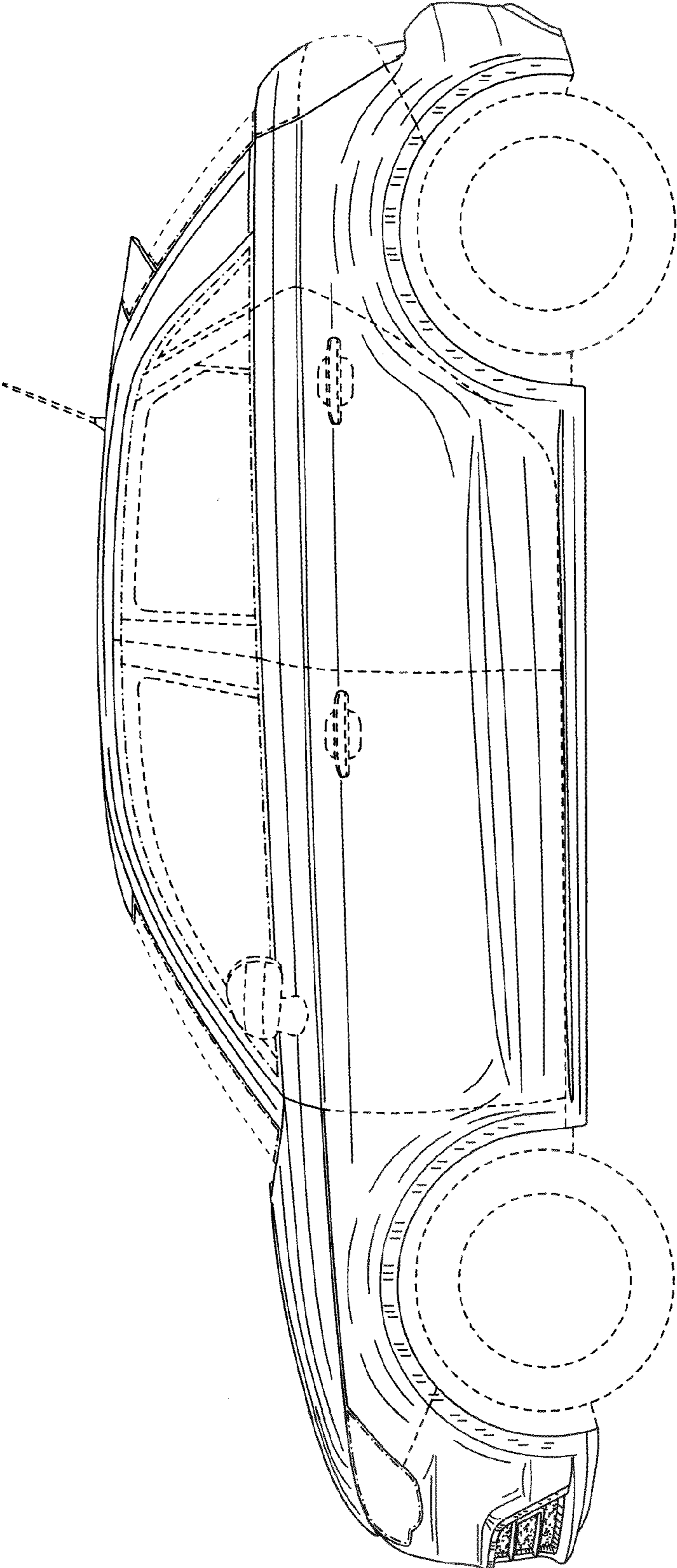

FIG. 2

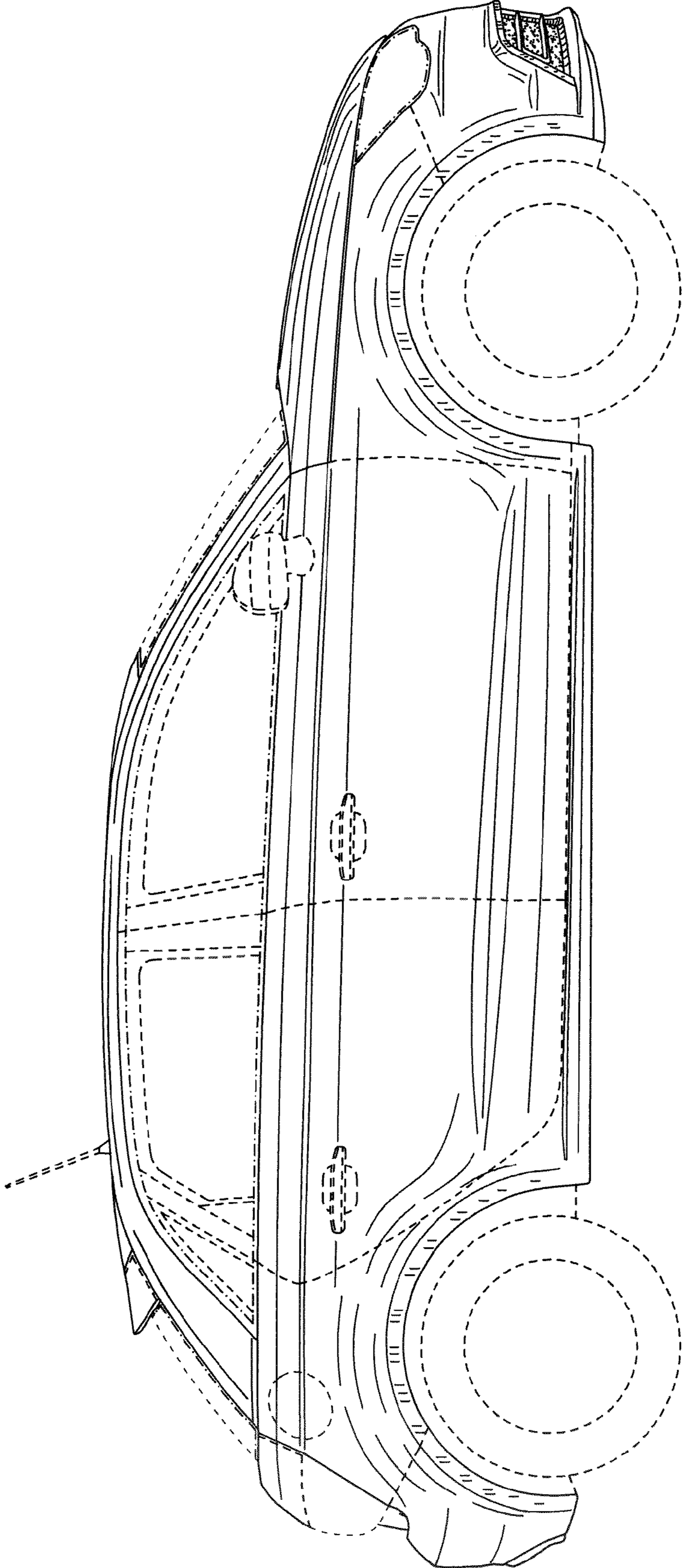

FIG. 3

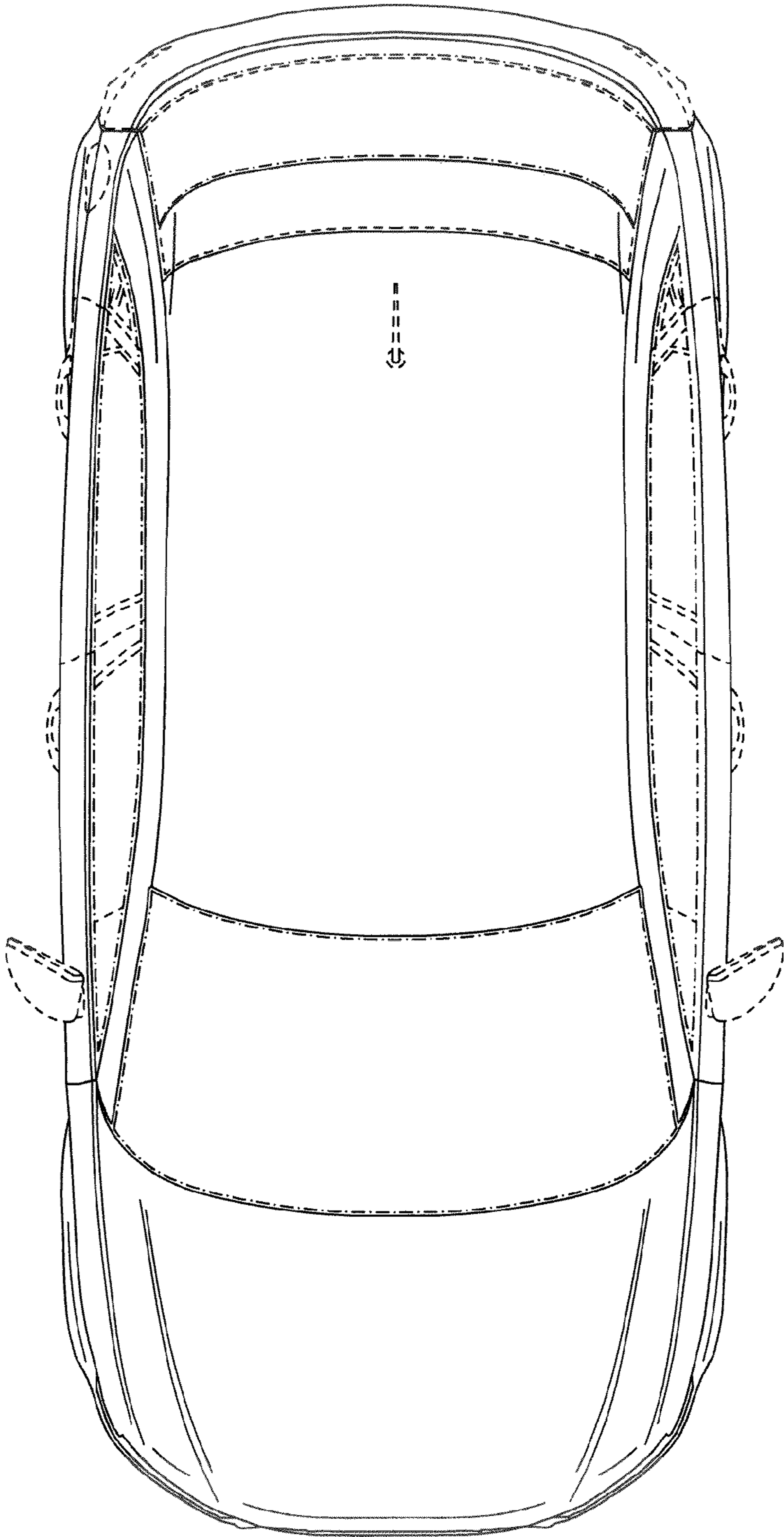

FIG. 4

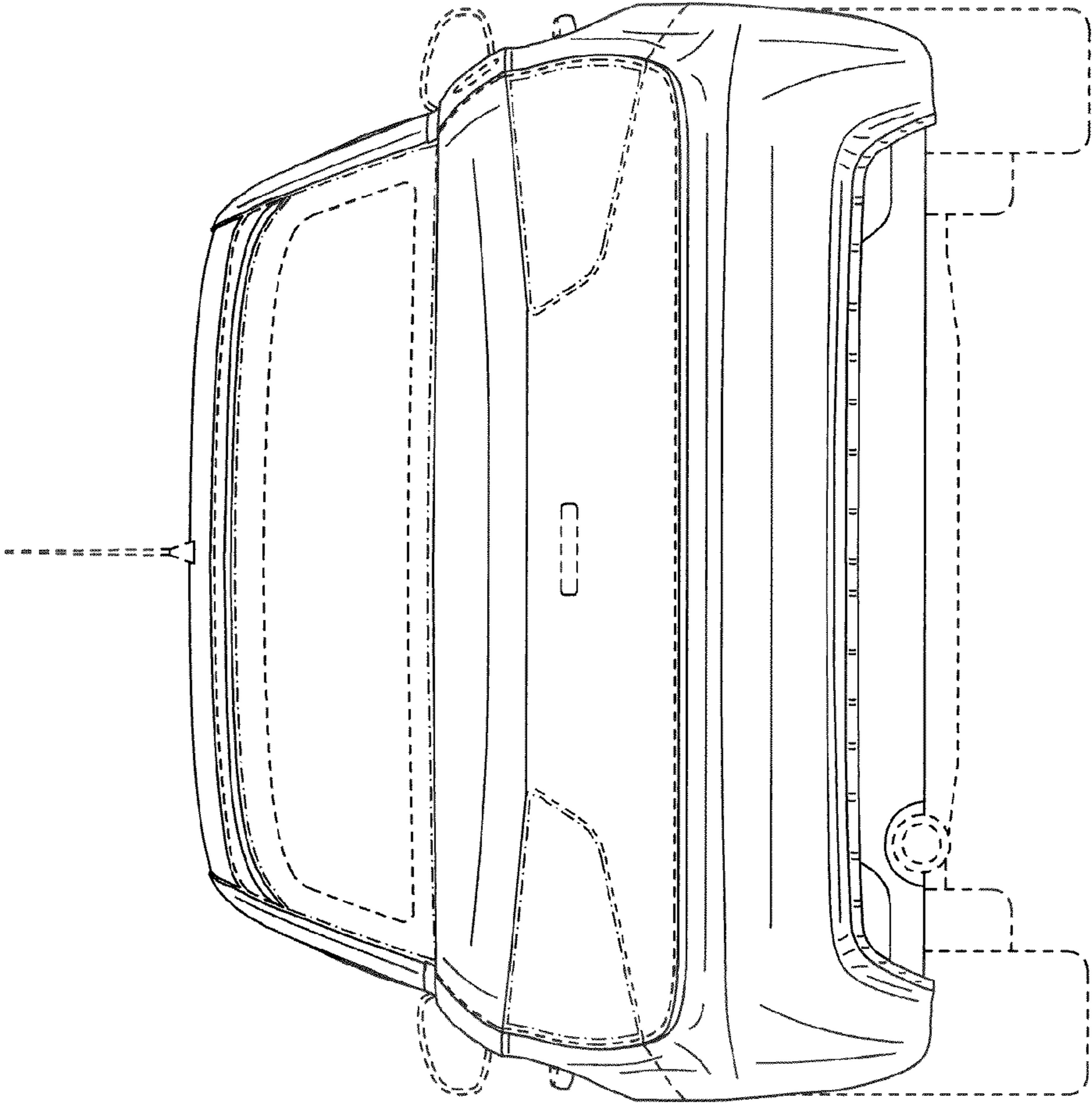

FIG. 5

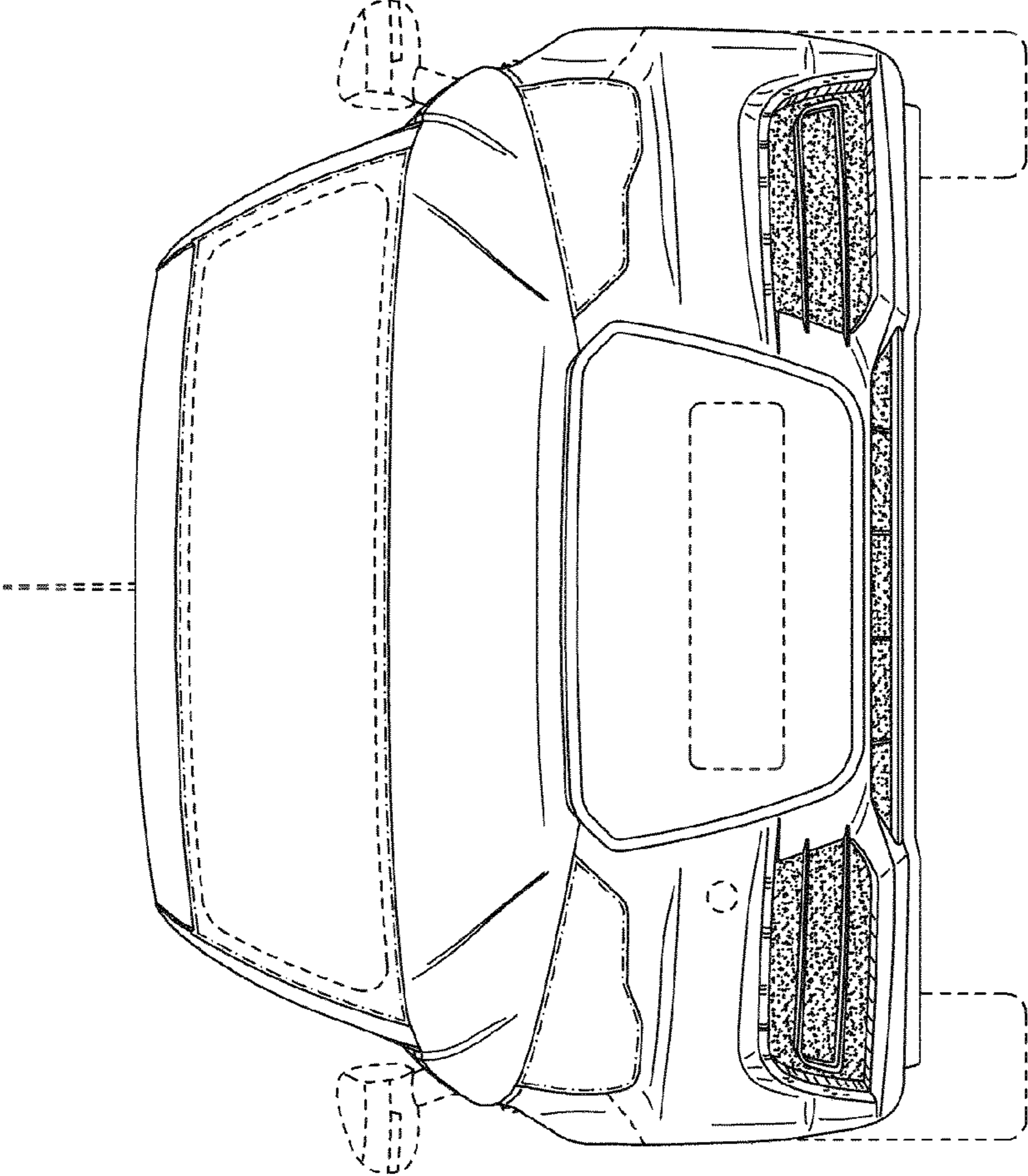

FIG. 6

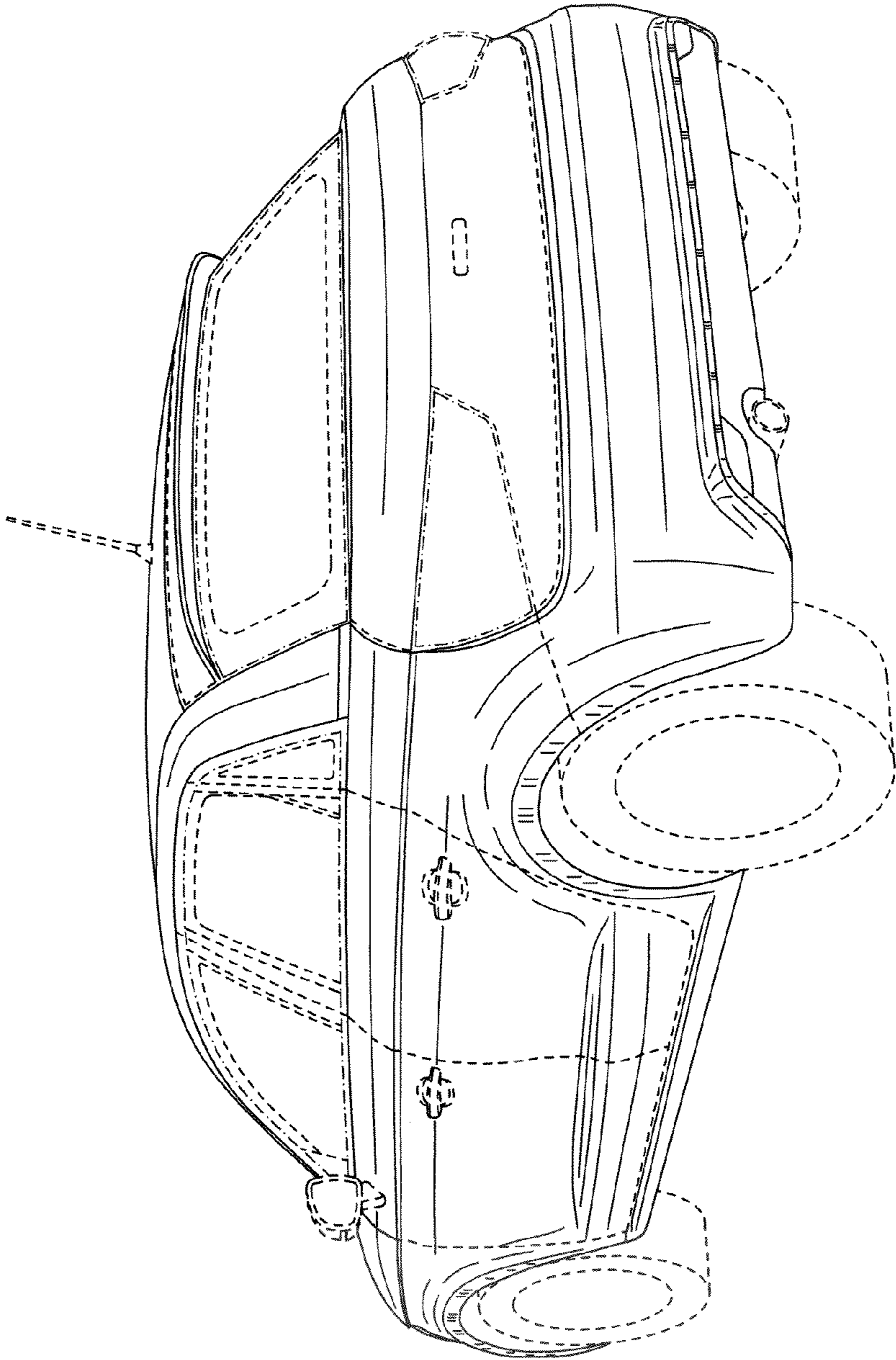

FIG. 7