



US00D711757S

(12) **United States Design Patent**
Dasbach

(10) **Patent No.:** **US D711,757 S**

(45) **Date of Patent:** **** Aug. 26, 2014**

(54) **MOUNT FOR A CYCLOMETER**

(71) Applicant: **Robert Bosch GmbH**, Stuttgart (DE)

(72) Inventor: **Gregor Dasbach**, Mondeville (FR)

(73) Assignee: **Robert Bosch GmbH**, Stuttgart (DE)

(**) Term: **14 Years**

(21) Appl. No.: **29/443,360**

(22) Filed: **Jan. 16, 2013**

(30) **Foreign Application Priority Data**

Jul. 17, 2012 (EM) 002075234

(51) **LOC (10) Cl.** **10-04**

(52) **U.S. Cl.**
USPC **D10/103**

(58) **Field of Classification Search**

CPC B62K 21/12; B62K 21/16; B62K 21/125;
B62K 23/06; B62K 25/04; B62K 11/14;
B62J 99/00; B62J 2099/0026; B62J 2099/004;
B62J 2099/0013; B62J 2099/0033; B62J 3/00;
G01C 22/002; G01P 3/489; G01P 1/04;
G01P 1/06; A45F 5/102
USPC D10/46, 65, 70, 98, 103; 73/490,
73/514.39; 74/551.1, 551.8; 235/95 R;
324/160-180, 207.13, 207.22, 207.25;
340/432, 427, 426.19, 426.22, 426.24;
474/69; 701/1, 2, 541; 702/145-154,
702/160

See application file for complete search history.

(56) **References Cited**

U.S. PATENT DOCUMENTS

D338,840 S * 8/1993 Ueda D10/98
5,644,511 A * 7/1997 McWhorter 702/148

6,588,297 B1 * 7/2003 Day et al. 74/551.8
D522,896 S * 6/2006 Okuda et al. D10/98
7,379,798 B2 * 5/2008 Takeda et al. 701/1
7,667,958 B2 * 2/2010 Ueda 361/679.26
7,915,554 B2 * 3/2011 Ueda et al. 200/315
D637,508 S * 5/2011 Ueda et al. D10/98
D645,371 S * 9/2011 Ueda et al. D10/98
8,149,098 B2 * 4/2012 Miglioranza 340/432
D680,890 S * 4/2013 Ueda et al. D10/98
2002/0020249 A1 * 2/2002 Darland et al. 74/551.8
2004/0244526 A1 * 12/2004 Jones 74/551.1
2005/0231968 A1 * 10/2005 Yamamoto et al. 362/474

* cited by examiner

Primary Examiner — Antoine D Davis

(74) *Attorney, Agent, or Firm* — Maginot, Moore & Beck

(57) **CLAIM**

The ornamental design for a mount for a cyclometer, as shown and described.

DESCRIPTION

FIG. 1 is a perspective view of a mount for a cyclometer showing my new design;
FIG. 2 is right side elevational view showing the design for the mount for a cyclometer of FIG. 1;
FIG. 3 is a left side elevational view showing the design for the mount for a cyclometer of FIG. 1;
FIG. 4 is a front elevational view showing the design for the mount for a cyclometer of FIG. 1;
FIG. 5 is a rear elevational view showing the design for the mount for a cyclometer of FIG. 1;
FIG. 6 is a top plan view showing the design for the mount for a cyclometer of FIG. 1; and,
FIG. 7 is a bottom plan view showing the design for the mount for a cyclometer of FIG. 1.

1 Claim, 7 Drawing Sheets

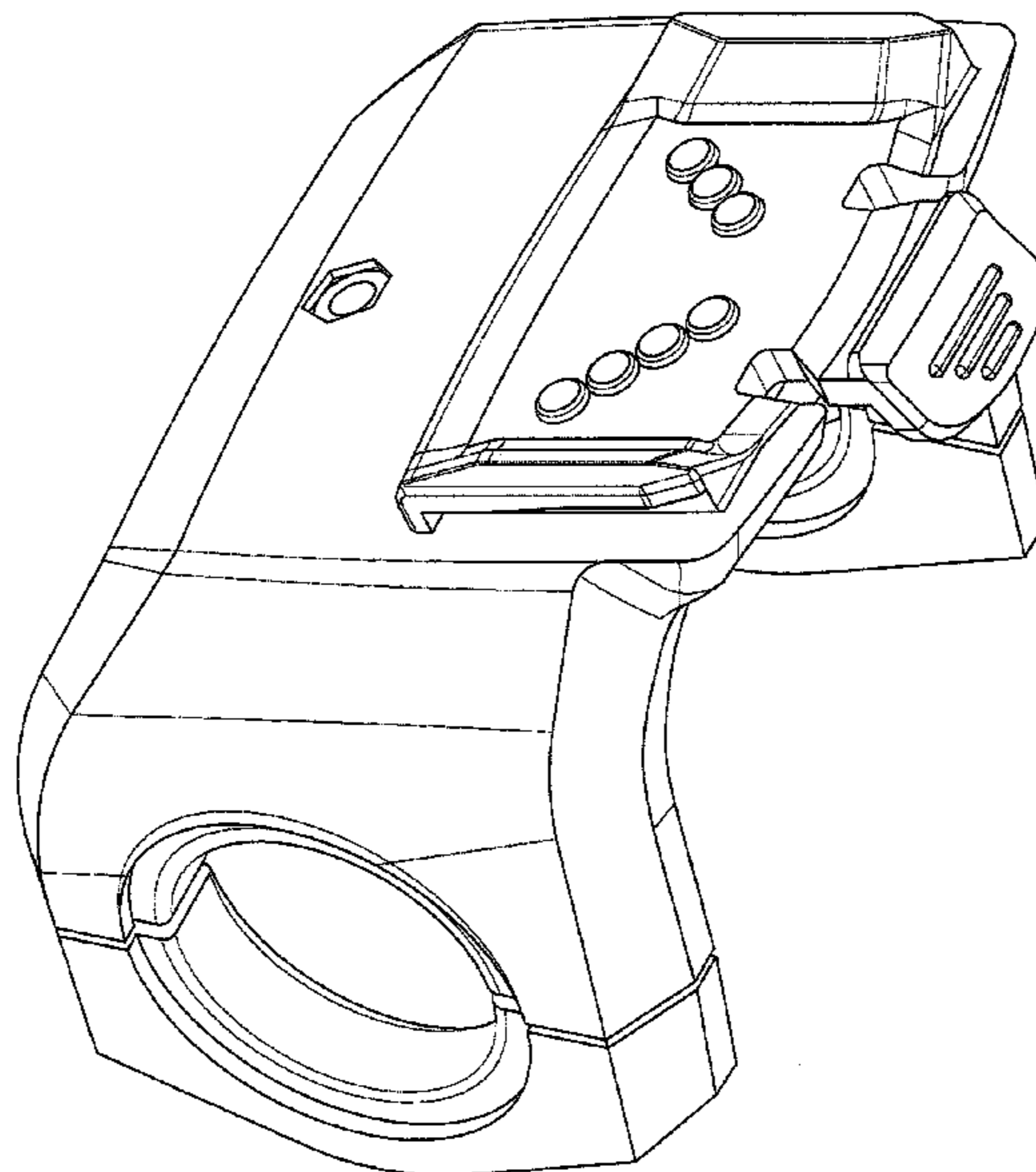

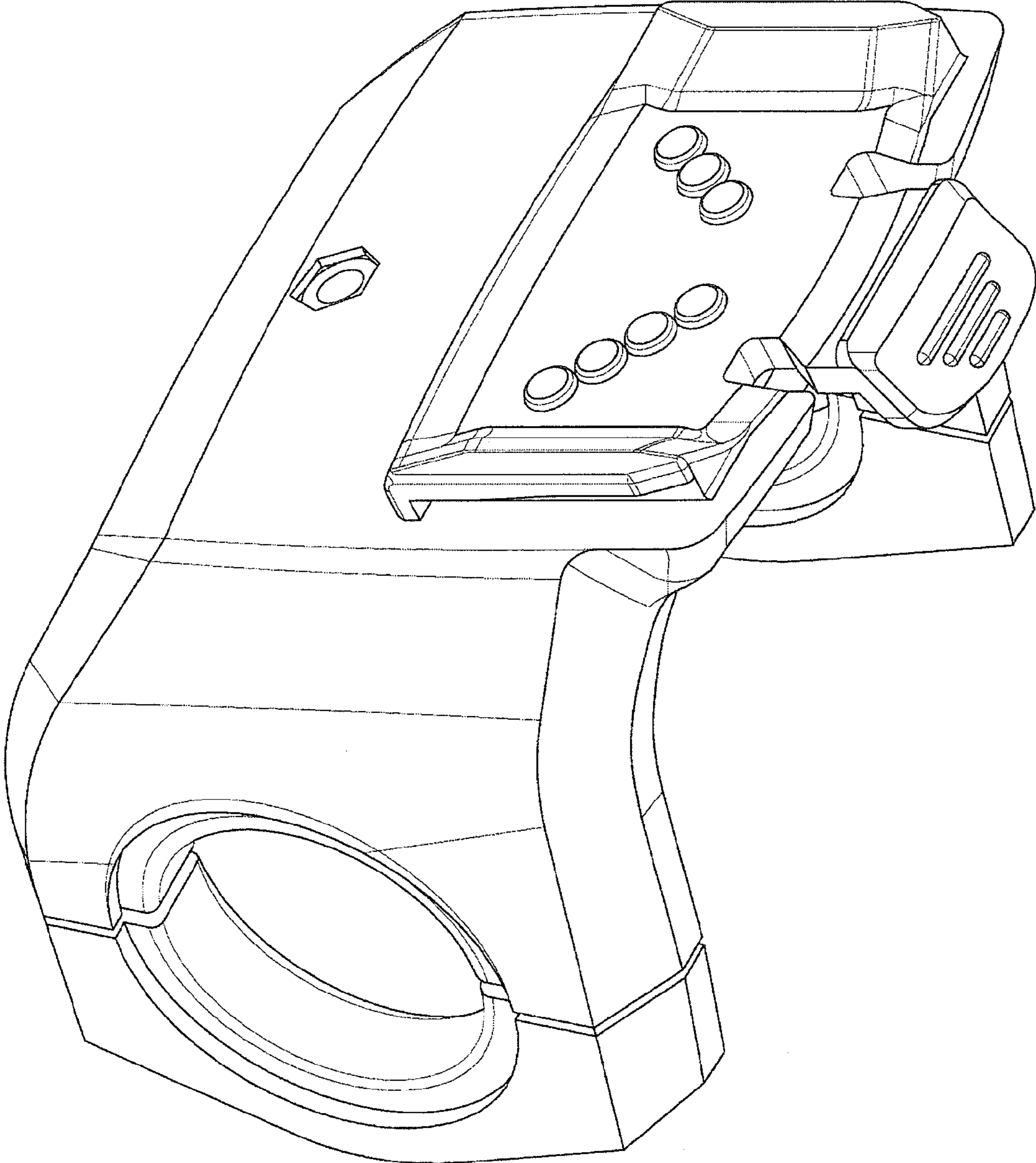

FIG. 1

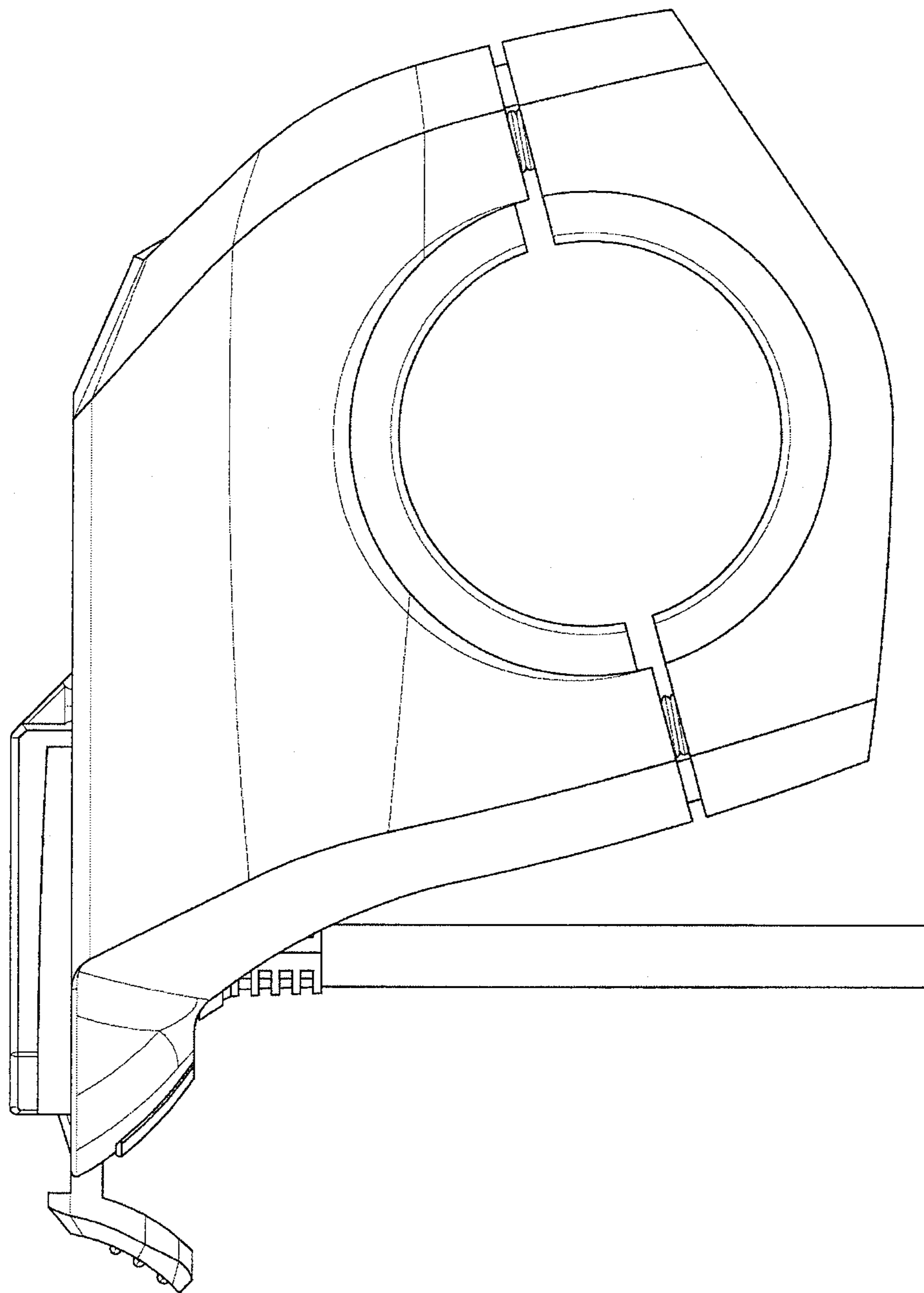

FIG. 2

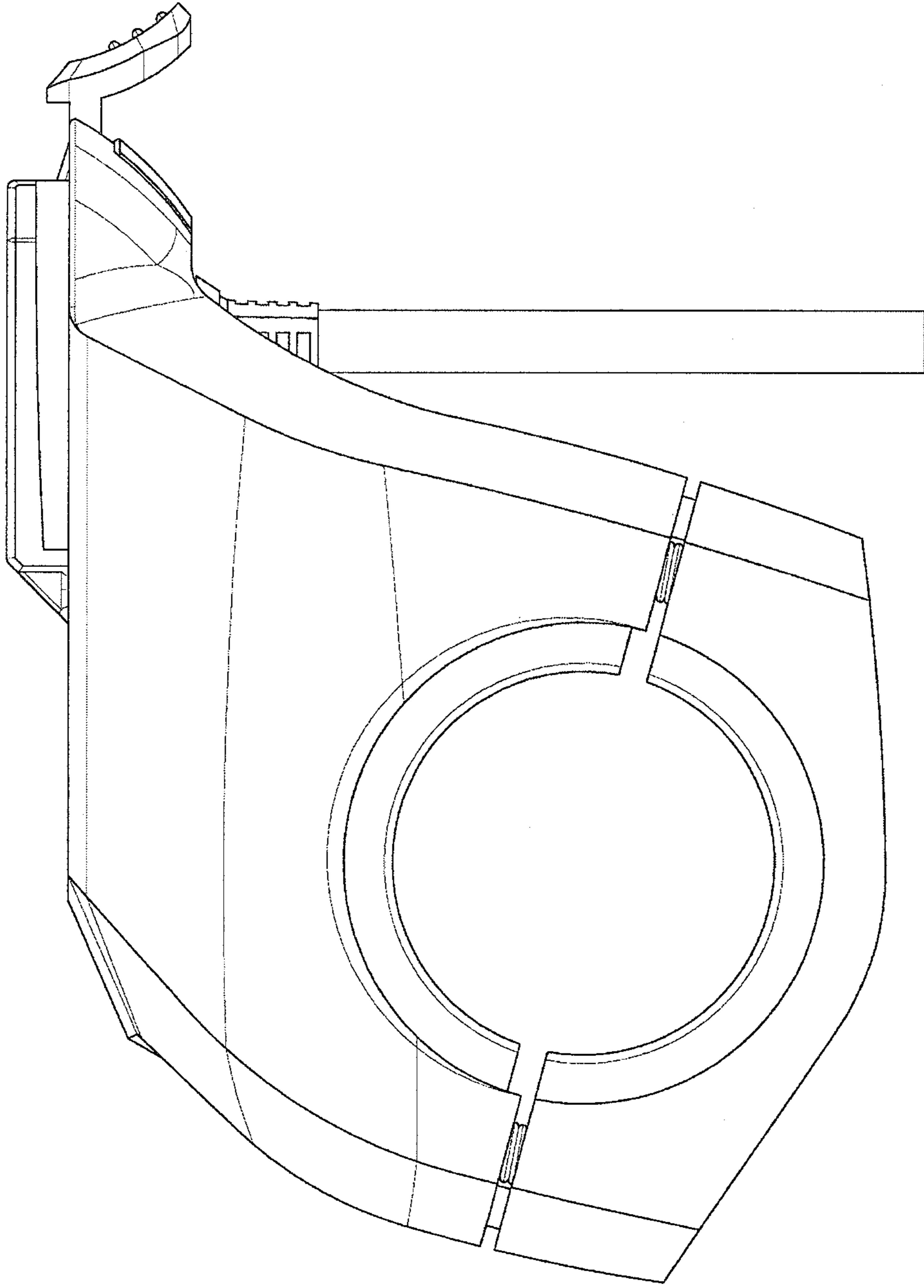

FIG. 3

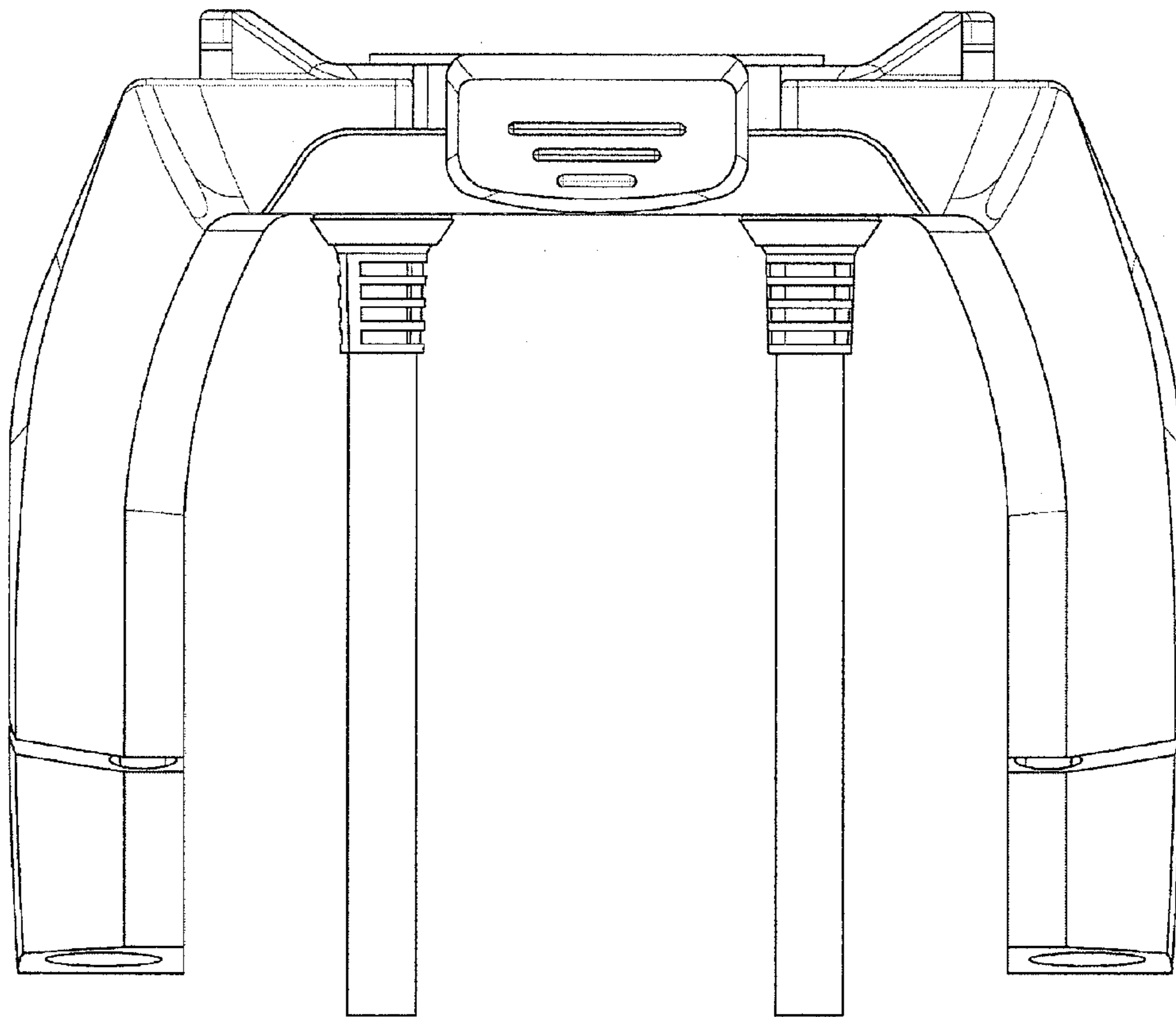

FIG. 4

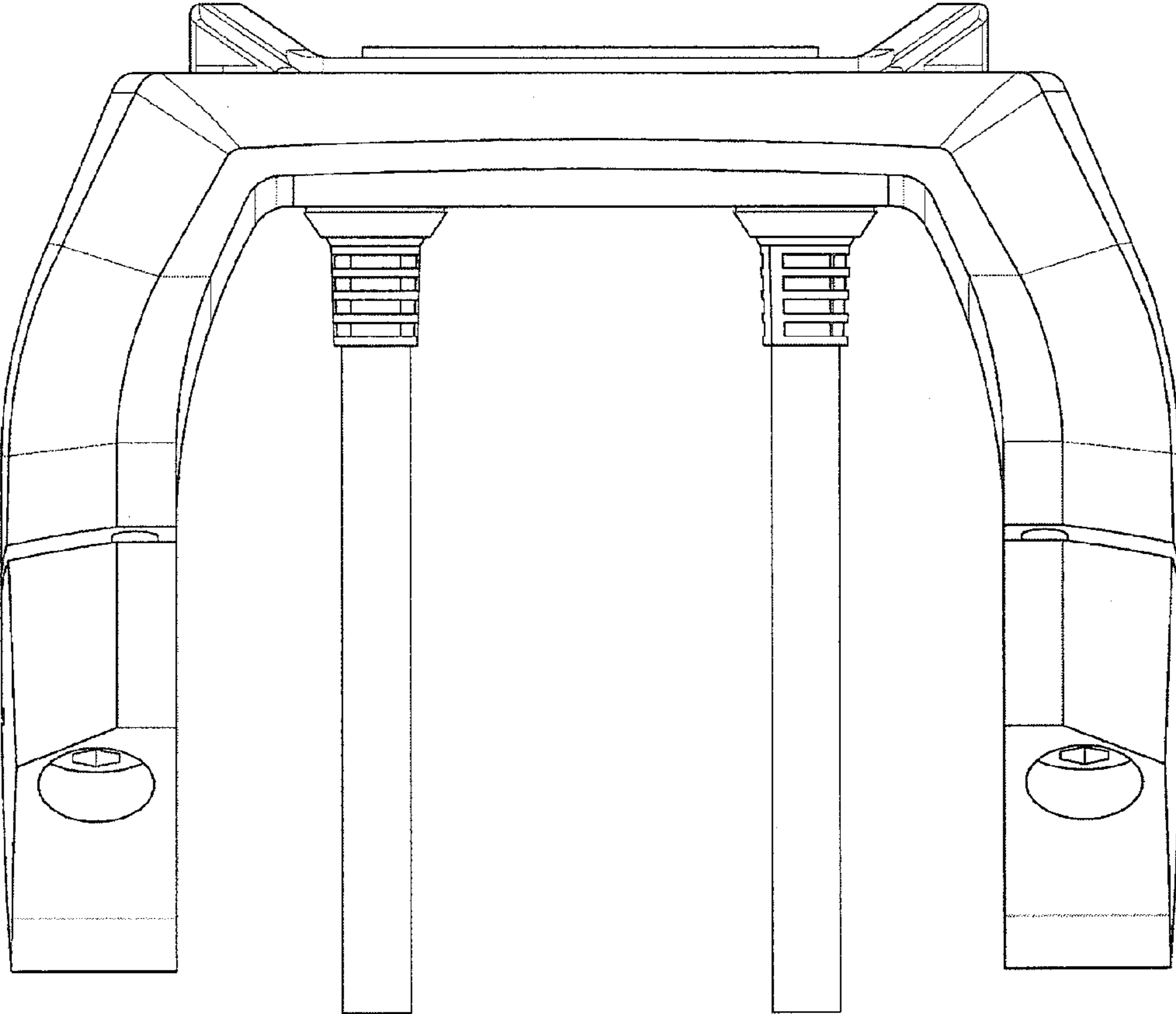

FIG. 5

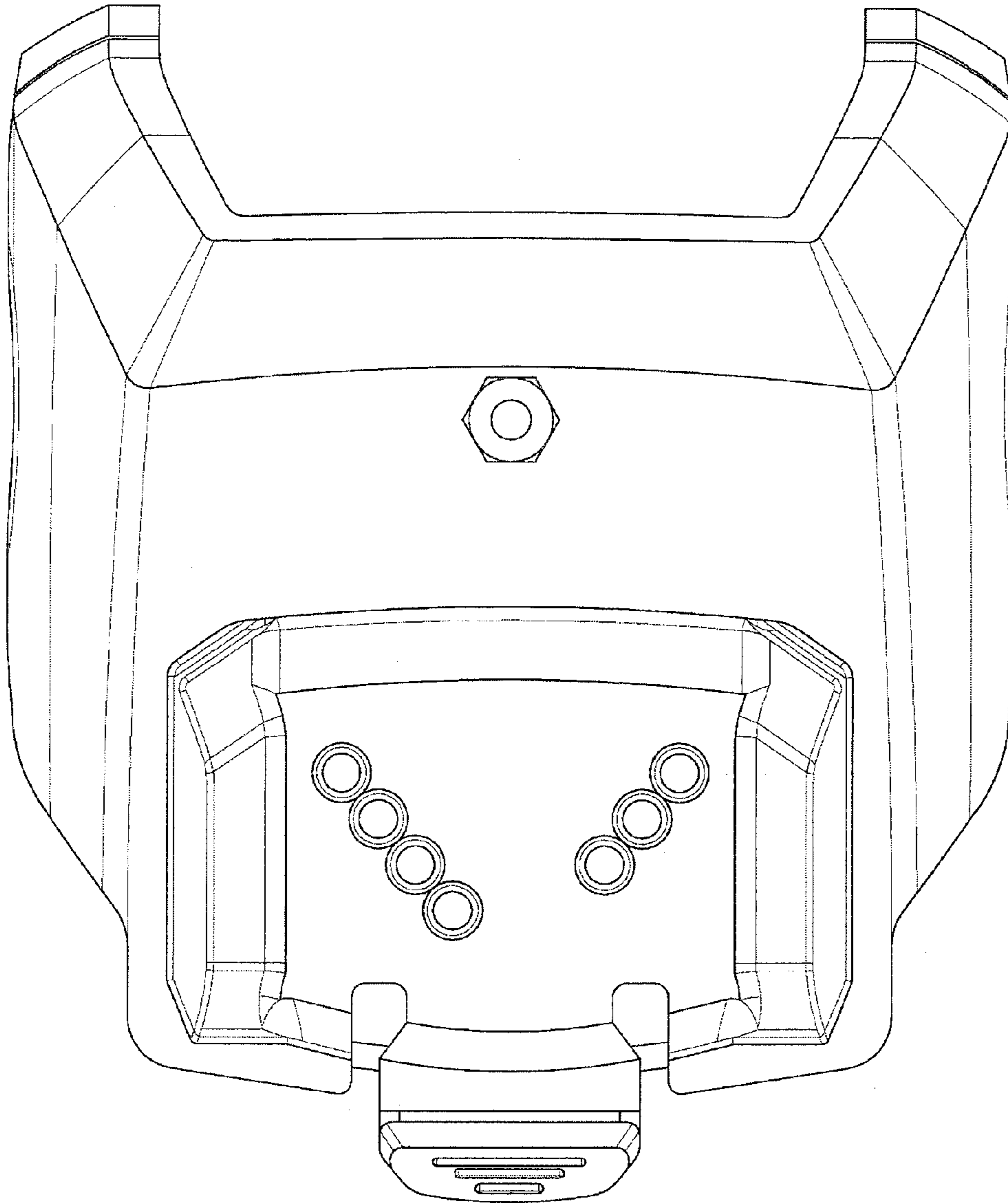

FIG. 6

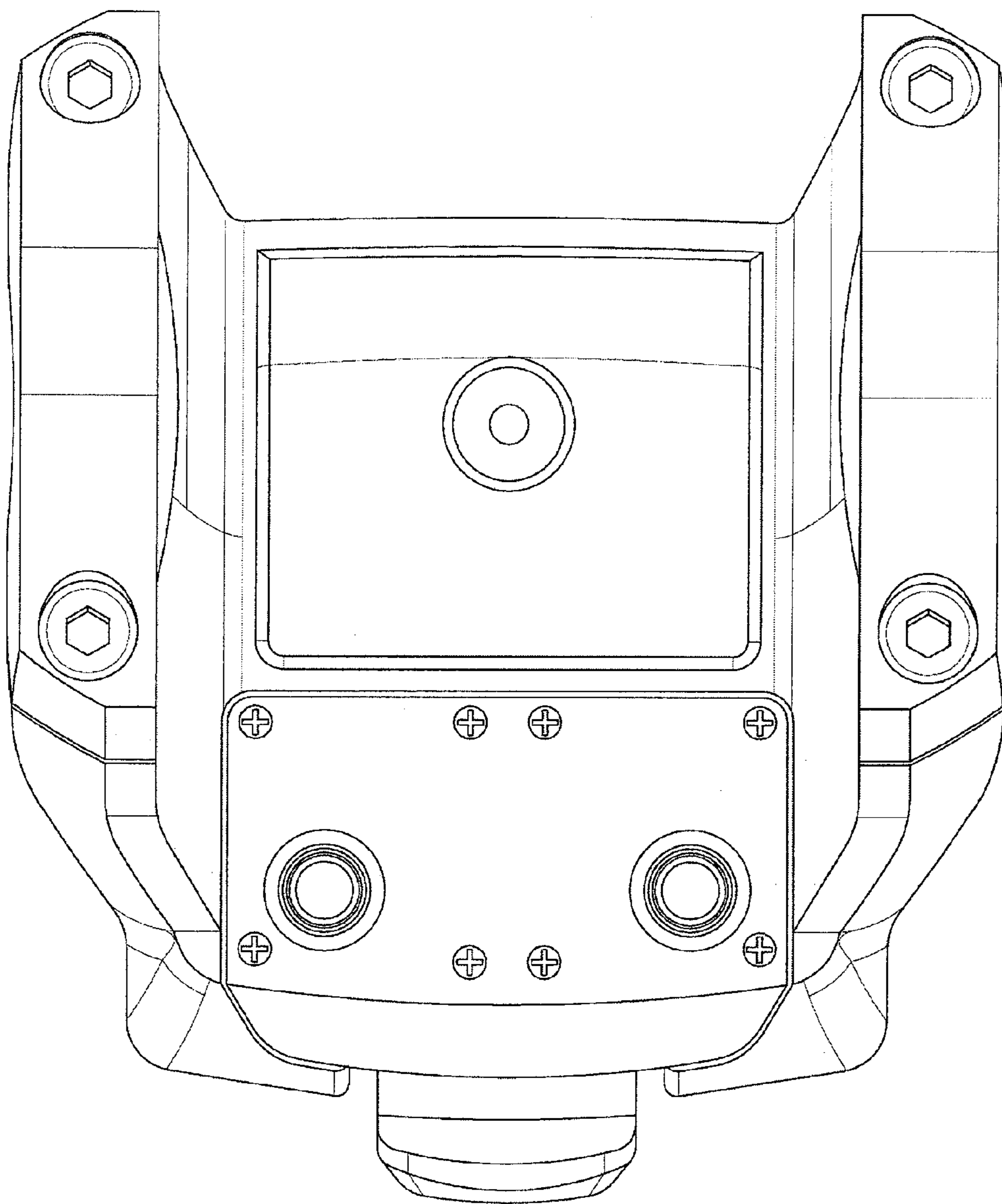

FIG. 7