



US00D711756S

(12) **United States Design Patent**
Dasbach

(10) **Patent No.:** **US D711,756 S**

(45) **Date of Patent:** **** Aug. 26, 2014**

(54) **CONTROL UNIT AND A MOUNT FOR THE CONTROL UNIT**

(71) Applicant: **Robert Bosch GmbH**, Stuttgart (DE)

(72) Inventor: **Gregor Dasbach**, Mondeville (FR)

(73) Assignee: **Robert Bosch GmbH**, Stuttgart (DE)

(**) Term: **14 Years**

(21) Appl. No.: **29/443,364**

(22) Filed: **Jan. 16, 2013**

(30) **Foreign Application Priority Data**

Jul. 17, 2012 (EM) 002075234

(51) **LOC (10) Cl.** **10-04**

(52) **U.S. Cl.**
USPC **D10/98; D10/70; D10/103**

(58) **Field of Classification Search**

CPC B62K 21/125; B62K 21/12; B62K 21/16;
B62K 23/06; B62K 25/04; B62K 11/14;
B62J 99/00; B62J 2099/0026; B62J 2099/004;
B62J 2099/0013; B62J 2099/0033; B62J 3/00;
G01C 22/002; G01P 3/489; G01P 1/04;
G01P 1/06; A45F 5/102
USPC D10/46, 65, 70, 98, 103; 73/490,
73/514.39; 74/551.1, 551.8; 235/95 R;
324/160-180, 207.13, 207.22, 207.24;
340/432, 427, 426.19, 426.22, 426.24;
474/69; 701/1, 2, 541; 702/145-154,
702/158, 160

See application file for complete search history.

(56) **References Cited**

U.S. PATENT DOCUMENTS

D338,840	S *	8/1993	Ueda	D10/98
5,644,511	A *	7/1997	McWhorter	702/148
6,588,297	B1 *	7/2003	Day et al.	74/551.8
D522,896	S *	6/2006	Okuda et al.	D10/98
7,379,798	B2 *	5/2008	Takeda et al.	701/1
7,667,958	B2 *	2/2010	Ueda	361/679.26
7,915,554	B2 *	3/2011	Ueda et al.	200/315
D637,508	S *	5/2011	Ueda et al.	D10/98
D645,371	S *	9/2011	Ueda et al.	D10/98
8,149,098	B2 *	4/2012	Miglioranza	340/432
D680,890	S *	4/2013	Ueda et al.	D10/98
2002/0020249	A1 *	2/2002	Darland et al.	74/551.8
2004/0244526	A1 *	12/2004	Jones	74/551.1
2005/0231968	A1 *	10/2005	Yamamoto et al.	362/474

* cited by examiner

Primary Examiner — Antoine D Davis

(74) *Attorney, Agent, or Firm* — Maginot, Moore & Beck

(57) **CLAIM**

The ornamental design for a control unit and a mount for the control unit, as shown and described.

DESCRIPTION

FIG. 1 is a perspective view of a control unit and a mount for the control unit showing my new design;
FIG. 2 is right side elevational view showing the design for the control unit and the mount for the control unit of FIG. 1;
FIG. 3 is a left side elevational view showing the design for the control unit and the mount for the control unit of FIG. 1;
FIG. 4 is a front elevational view showing the design for the control unit and the mount for the control unit of FIG. 1;
FIG. 5 is a rear elevational view showing the design for the control unit and the mount for the control unit of FIG. 1;
FIG. 6 is a top plan view showing the design for the control unit and the mount for the control unit of FIG. 1; and,
FIG. 7 is a bottom plan view showing the design for the control unit and the mount for the control unit of FIG. 1.

1 Claim, 7 Drawing Sheets

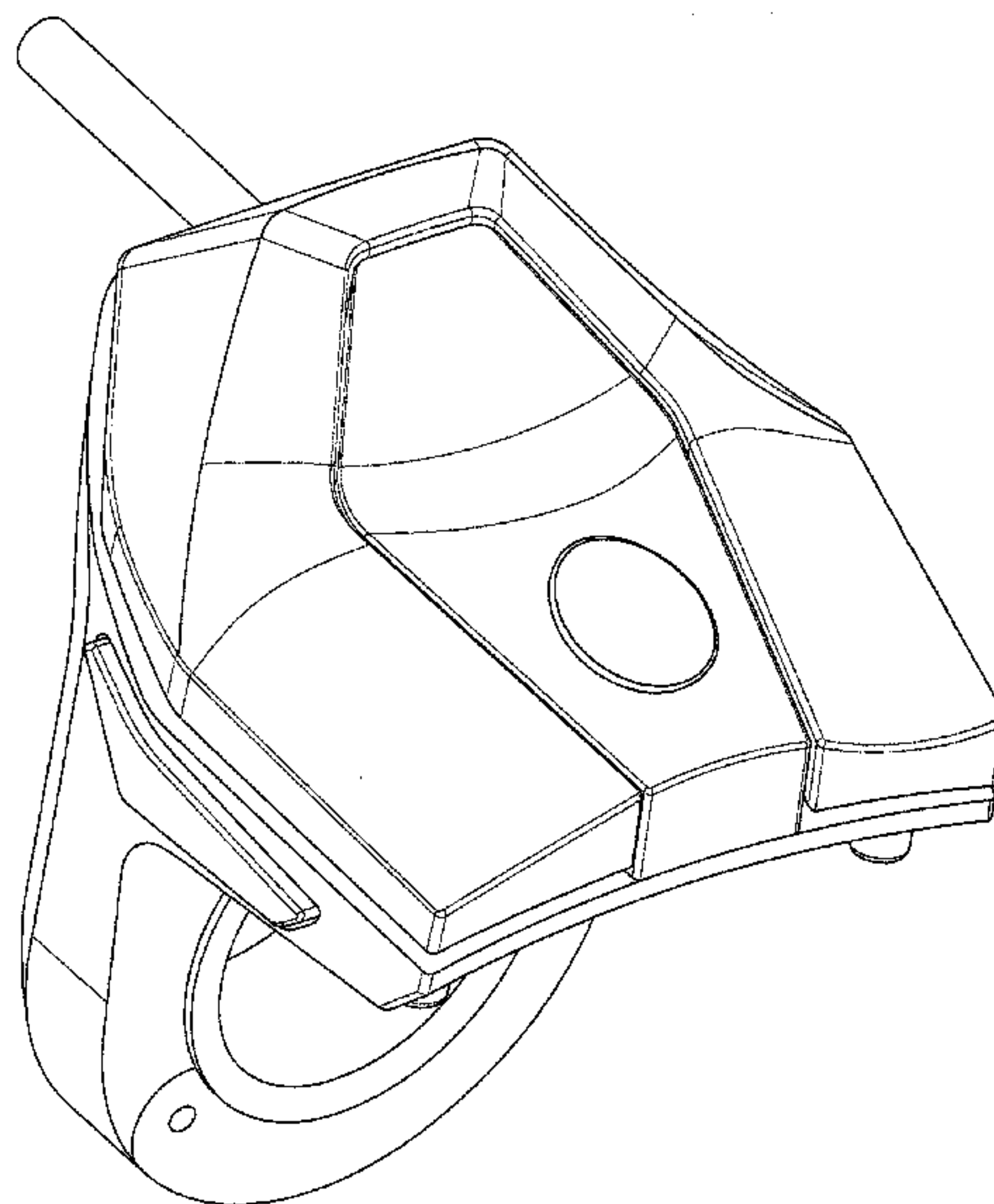

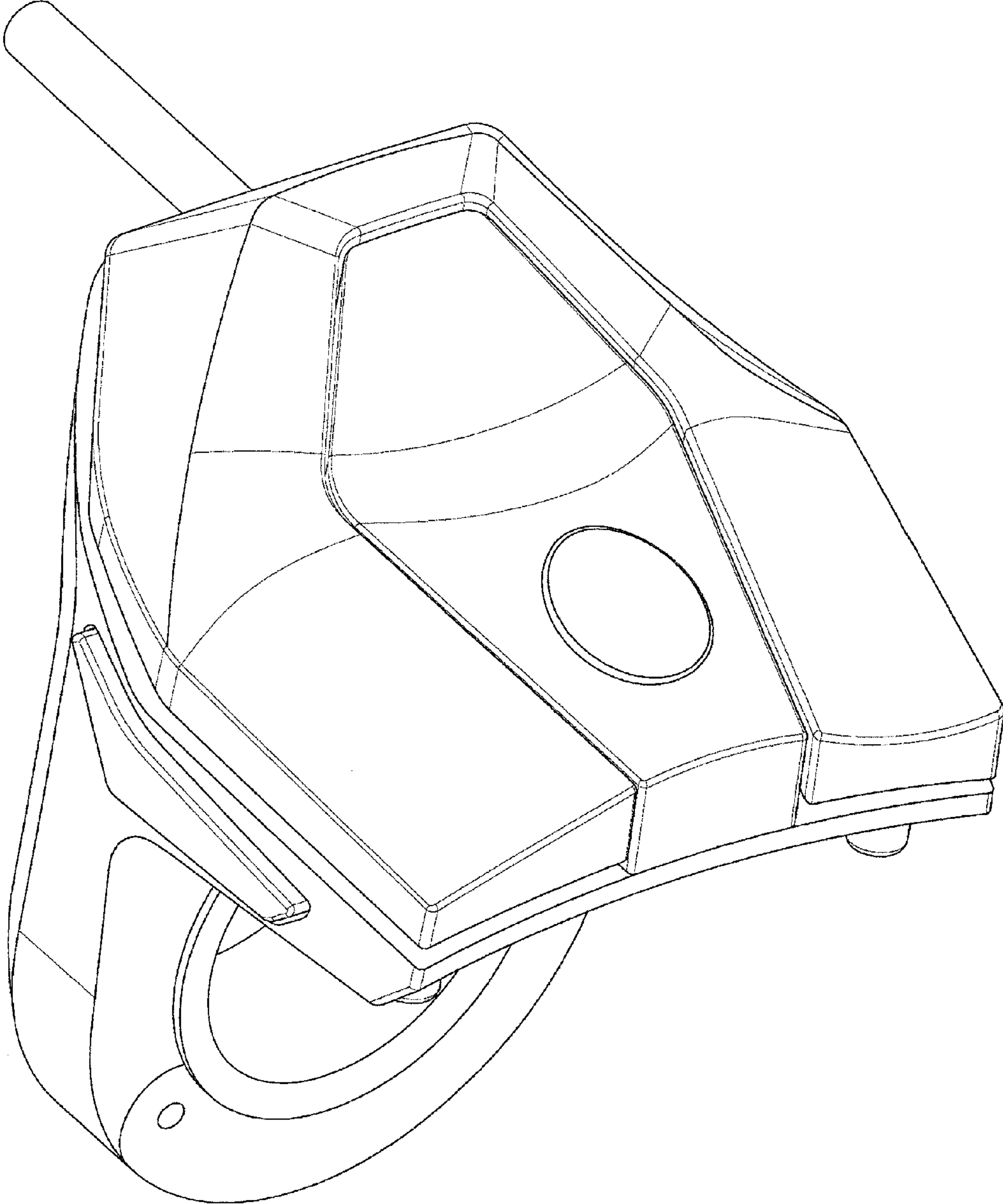

FIG. 1

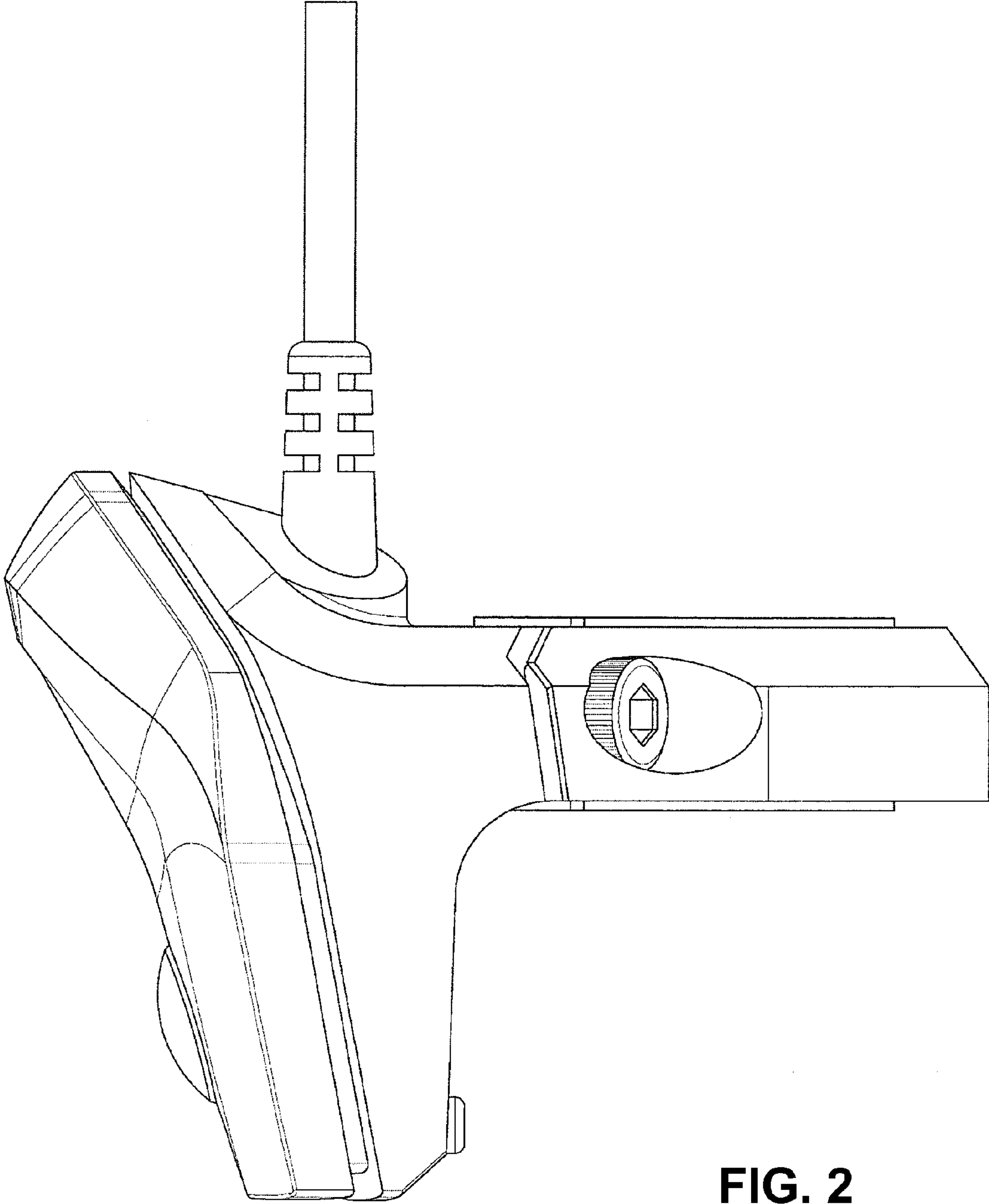

FIG. 2

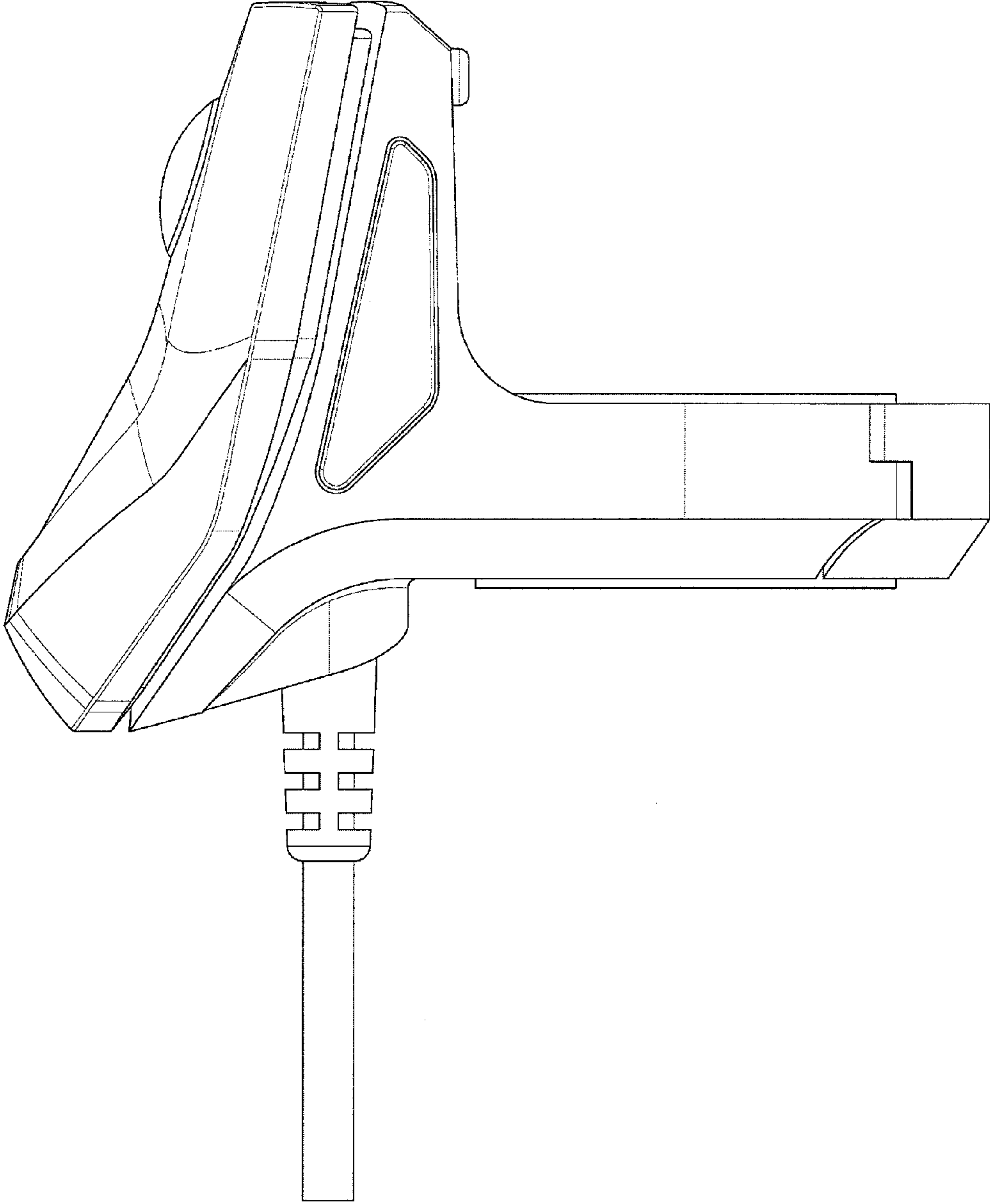

FIG. 3

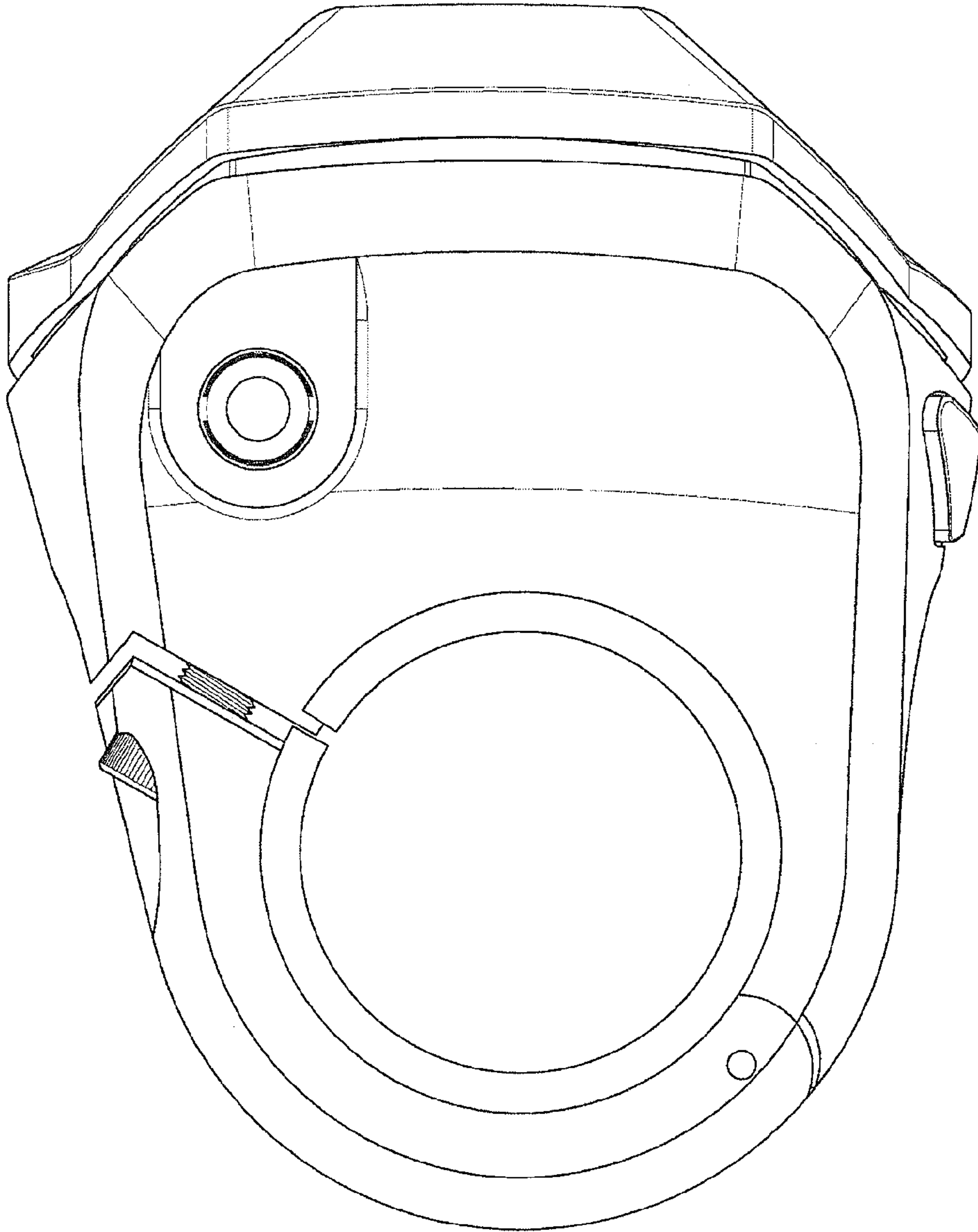

FIG. 4

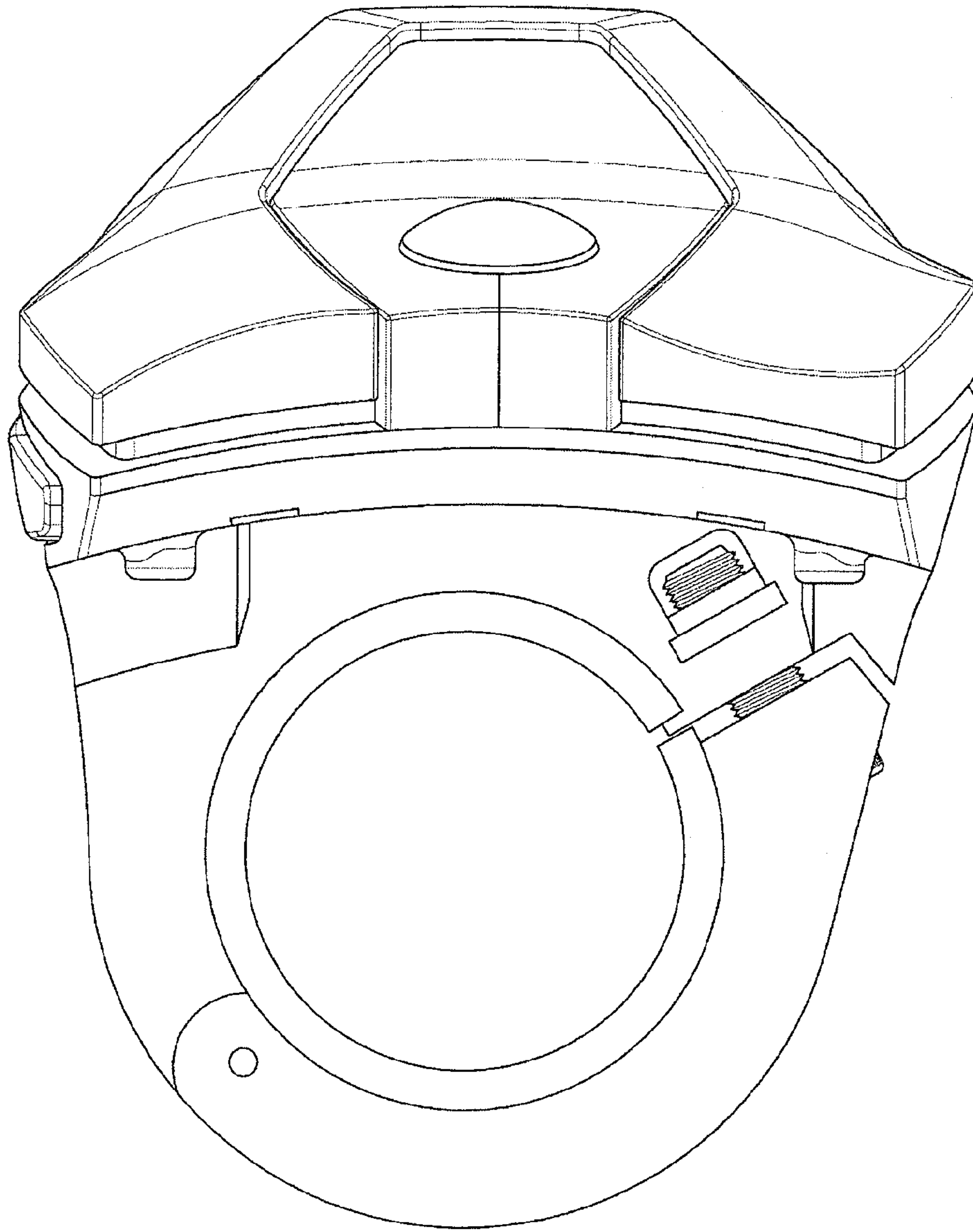

FIG. 5

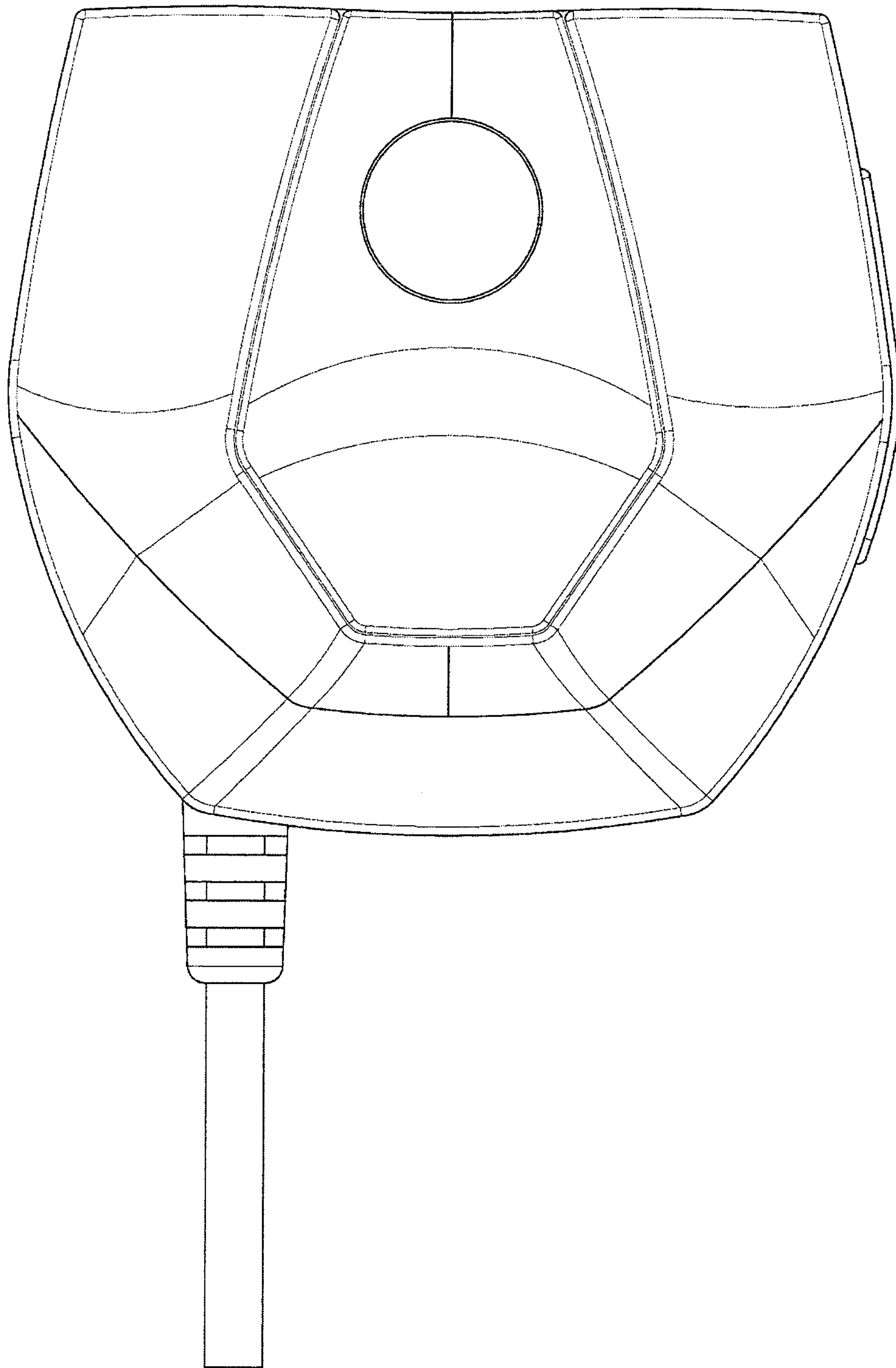

FIG. 6

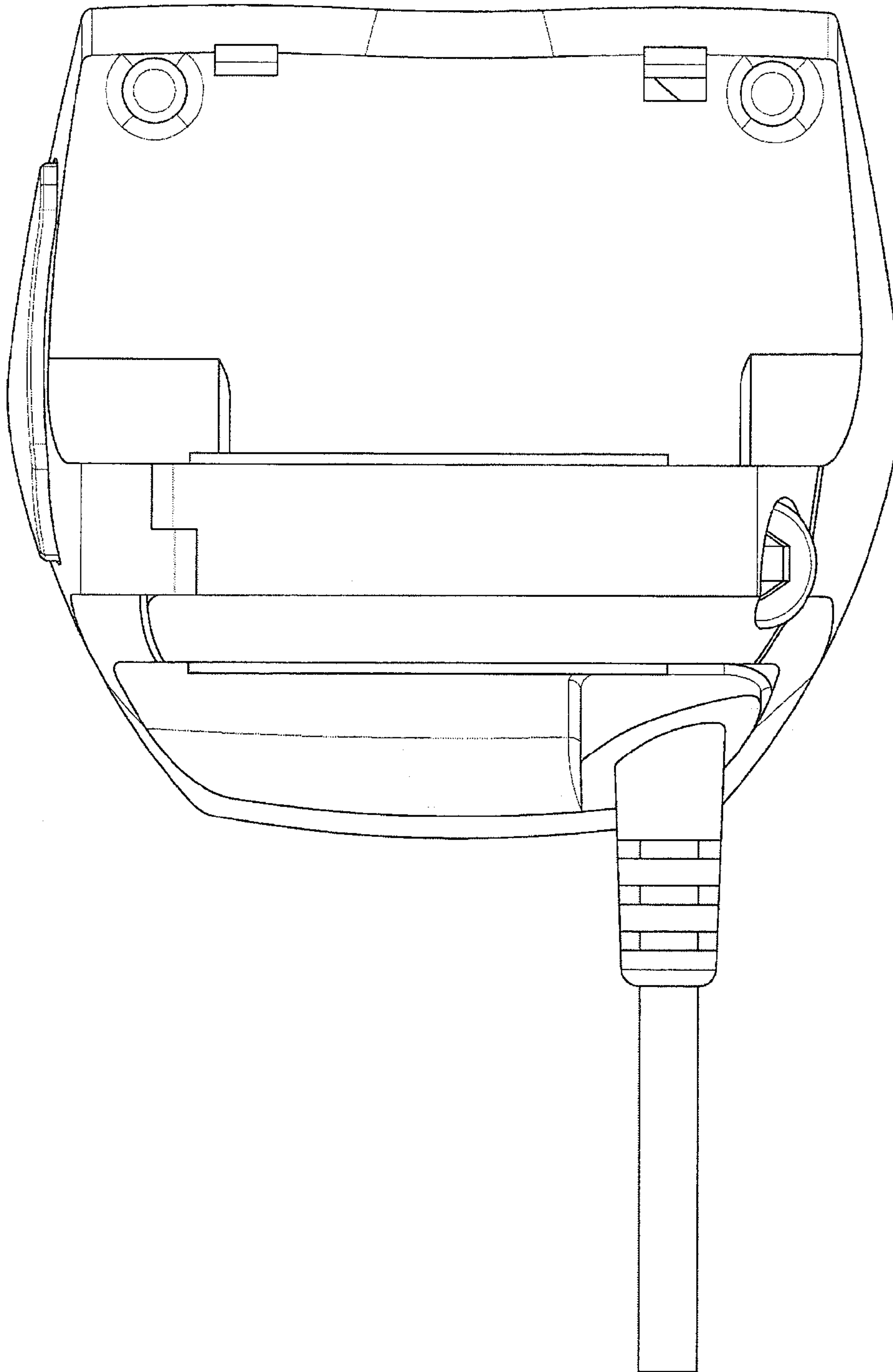

FIG. 7