



US00D711725S

(12) **United States Design Patent**
Bainbridge

(10) **Patent No.:** **US D711,725 S**

(45) **Date of Patent:** **** Aug. 26, 2014**

(54) **CORD LOCK**

(71) Applicant: **James R. Bainbridge**, Marcellus, MI
(US)

(72) Inventor: **James R. Bainbridge**, Marcellus, MI
(US)

(**) Term: **14 Years**

(21) Appl. No.: **29/448,327**

(22) Filed: **Mar. 12, 2013**

(51) **LOC (10) Cl.** **08-05**

(52) **U.S. Cl.**
USPC **D8/356**

(58) **Field of Classification Search**
USPC D8/356, 354, 349, 499, 383, 395, 396;
439/207, 208, 209, 210, 211, 445, 446,
439/447; 248/68.1, 49, 74.4; 385/59, 137;
604/179, 174, 93.01, 48, 19; 24/19 PB,
24/30.5 P, 17 AP

See application file for complete search history.

(56) **References Cited**

U.S. PATENT DOCUMENTS

D408,269 S *	4/1999	Ross	D8/356
D411,950 S *	7/1999	Dinh et al.	D8/356
D459,194 S *	6/2002	Johansson et al.	D8/356
D470,034 S *	2/2003	Wu et al.	D8/356
D473,448 S *	4/2003	Wu et al.	D8/356
D477,770 S *	7/2003	Baker et al.	D8/373
D487,536 S *	3/2004	Ågren	D32/31
D488,372 S *	4/2004	Gambrell	D8/356
D497,305 S *	10/2004	Perri et al.	D8/356

D497,793 S *	11/2004	Votypka	D8/356
D512,904 S *	12/2005	Thaler	D8/356
7,249,728 B2 *	7/2007	Williamson	242/566
D576,406 S *	9/2008	Chan	D3/318
D605,032 S *	12/2009	Bushey	D8/402
D625,986 S *	10/2010	Kolasa	D8/356
D628,465 S *	12/2010	Hernandez	D8/356
D629,671 S *	12/2010	Ohuri et al.	D8/356
D646,555 S *	10/2011	Galle	D8/356
D671,392 S *	11/2012	Von Euler	D8/356
D674,380 S *	1/2013	Soekoro	D14/250

* cited by examiner

Primary Examiner — Cynthia Underwood

(74) *Attorney, Agent, or Firm* — Flynn, Thiel, Boutell & Tanis, P.C.

(57) **CLAIM**

The ornamental design for a cord lock, as shown and described.

DESCRIPTION

FIG. 1 is a front, top and left end isometric view of my new cord lock;

FIG. 2 is a top view thereof;

FIG. 3 is a left end view, the right end view being a mirror image thereof;

FIG. 4 is a front view, the rear view being a mirror image thereof;

FIG. 5 is a front, bottom and left end isometric view thereof; and,

FIG. 6 is a bottom view thereof.

1 Claim, 3 Drawing Sheets

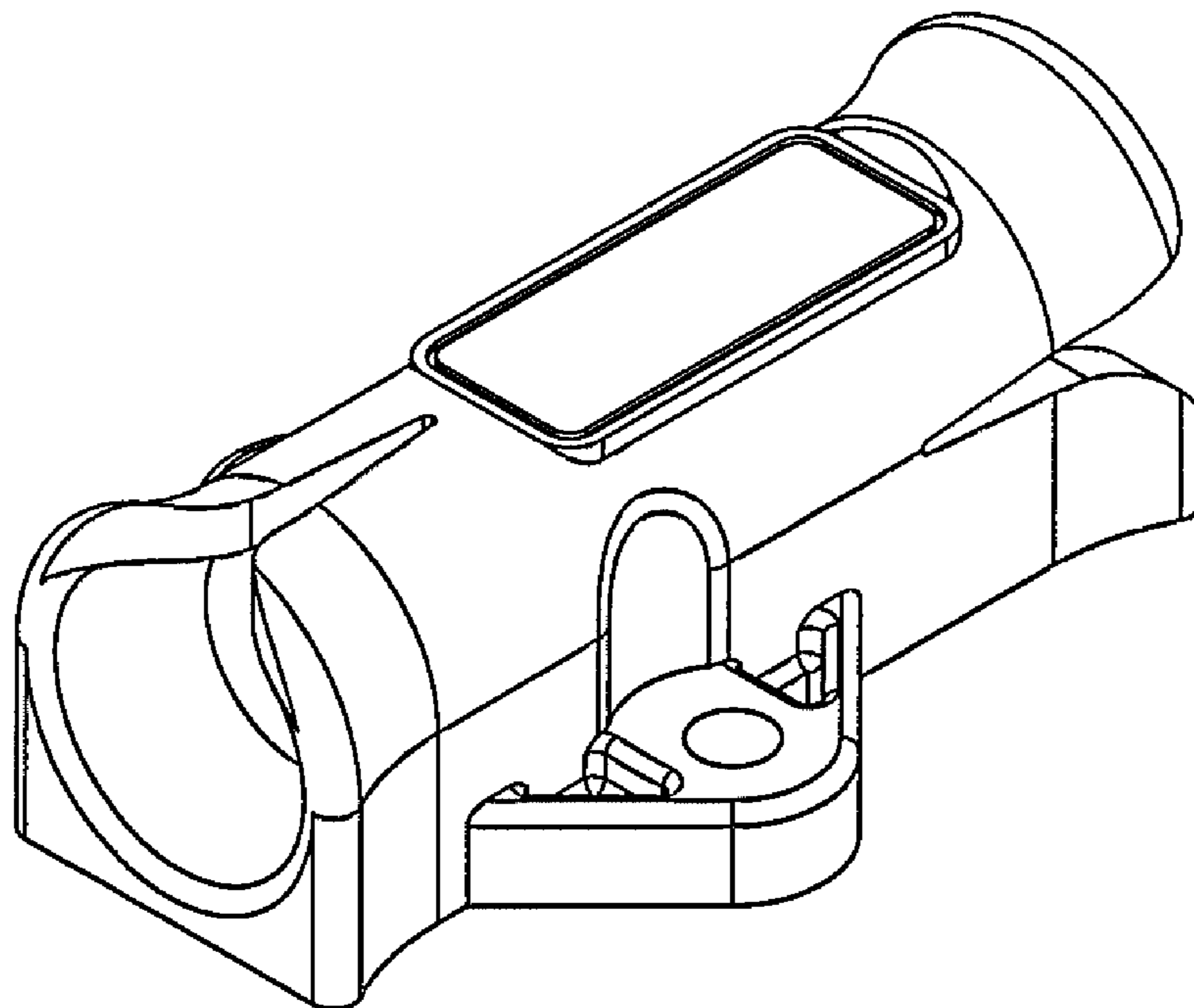

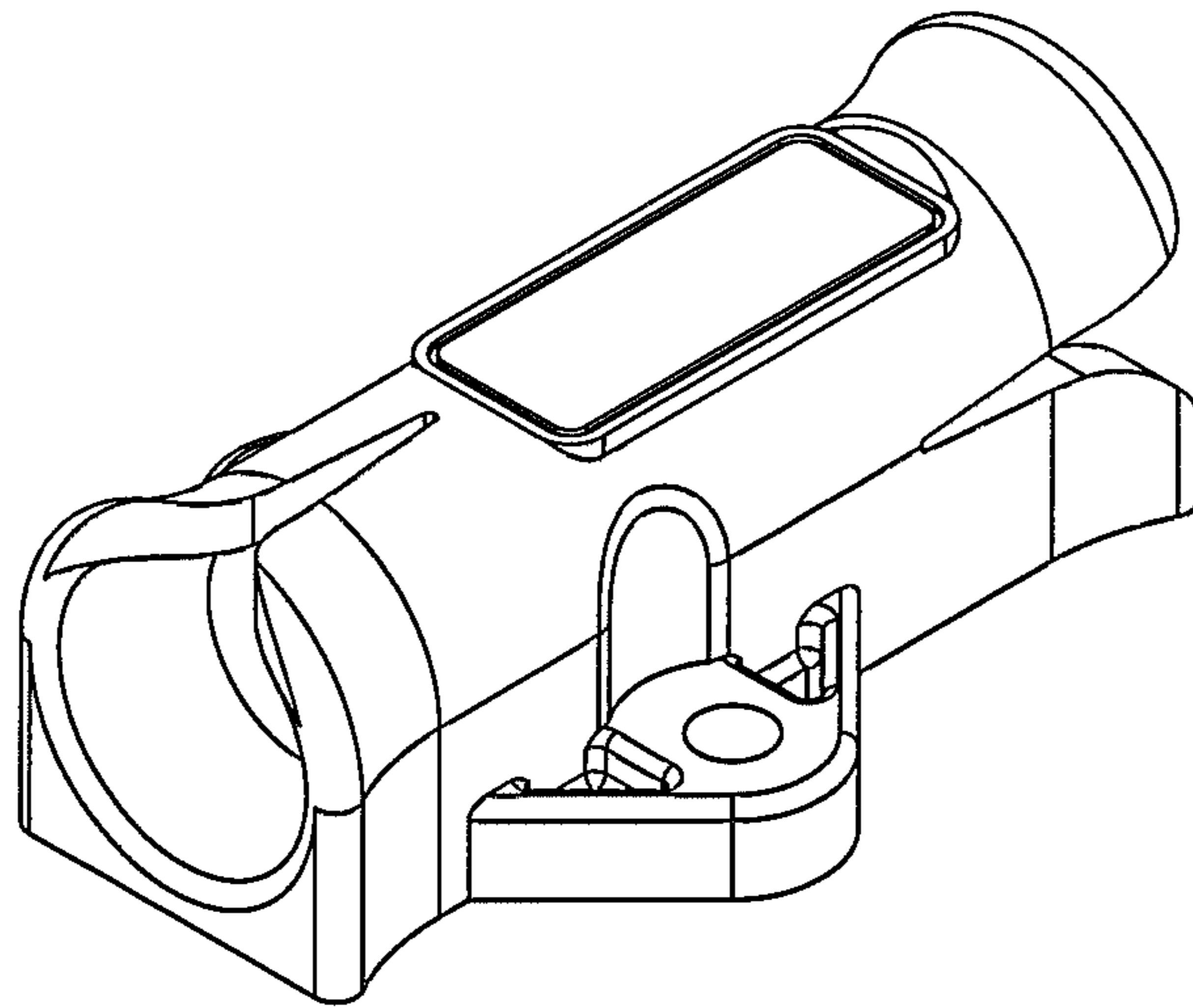

FIG. 1

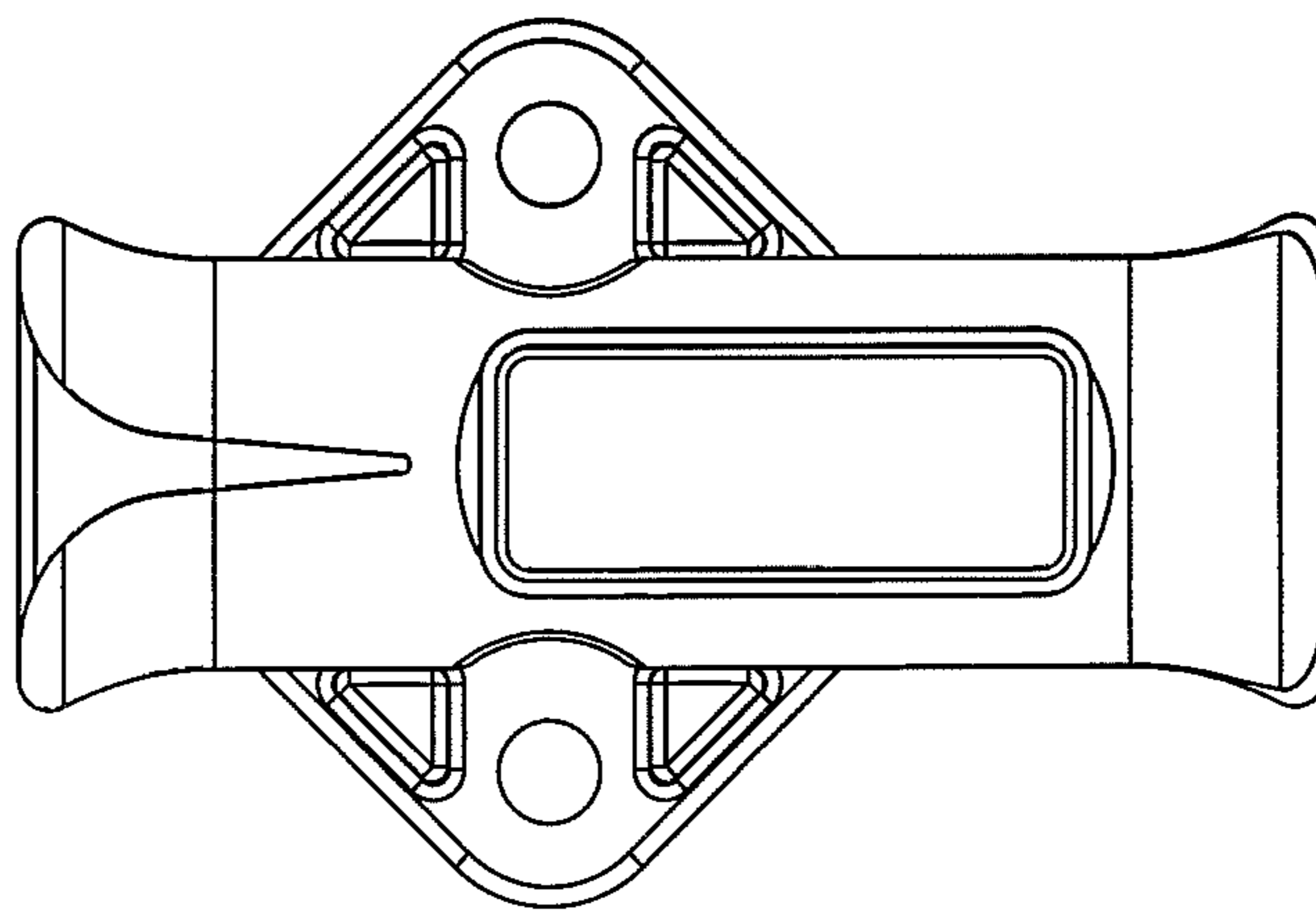

FIG. 2

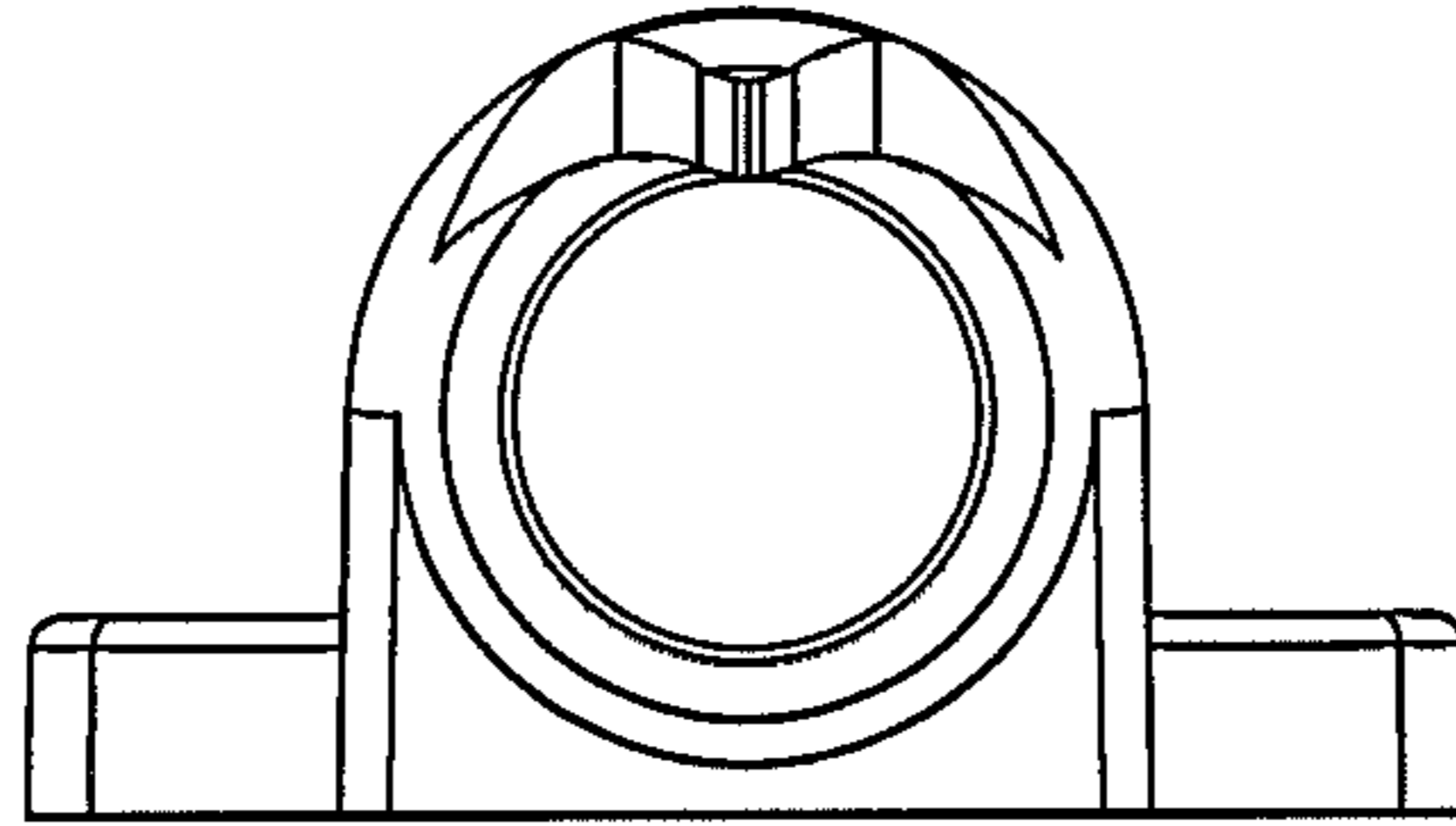

FIG. 3

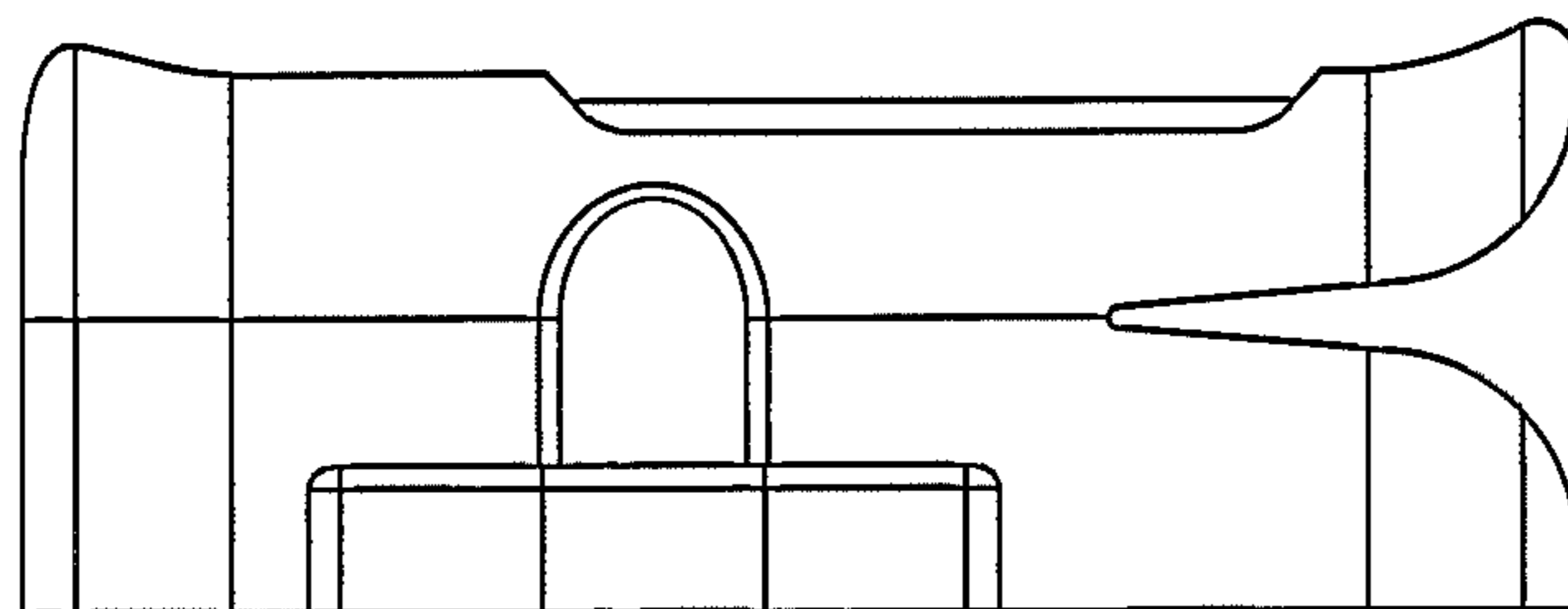

FIG. 4

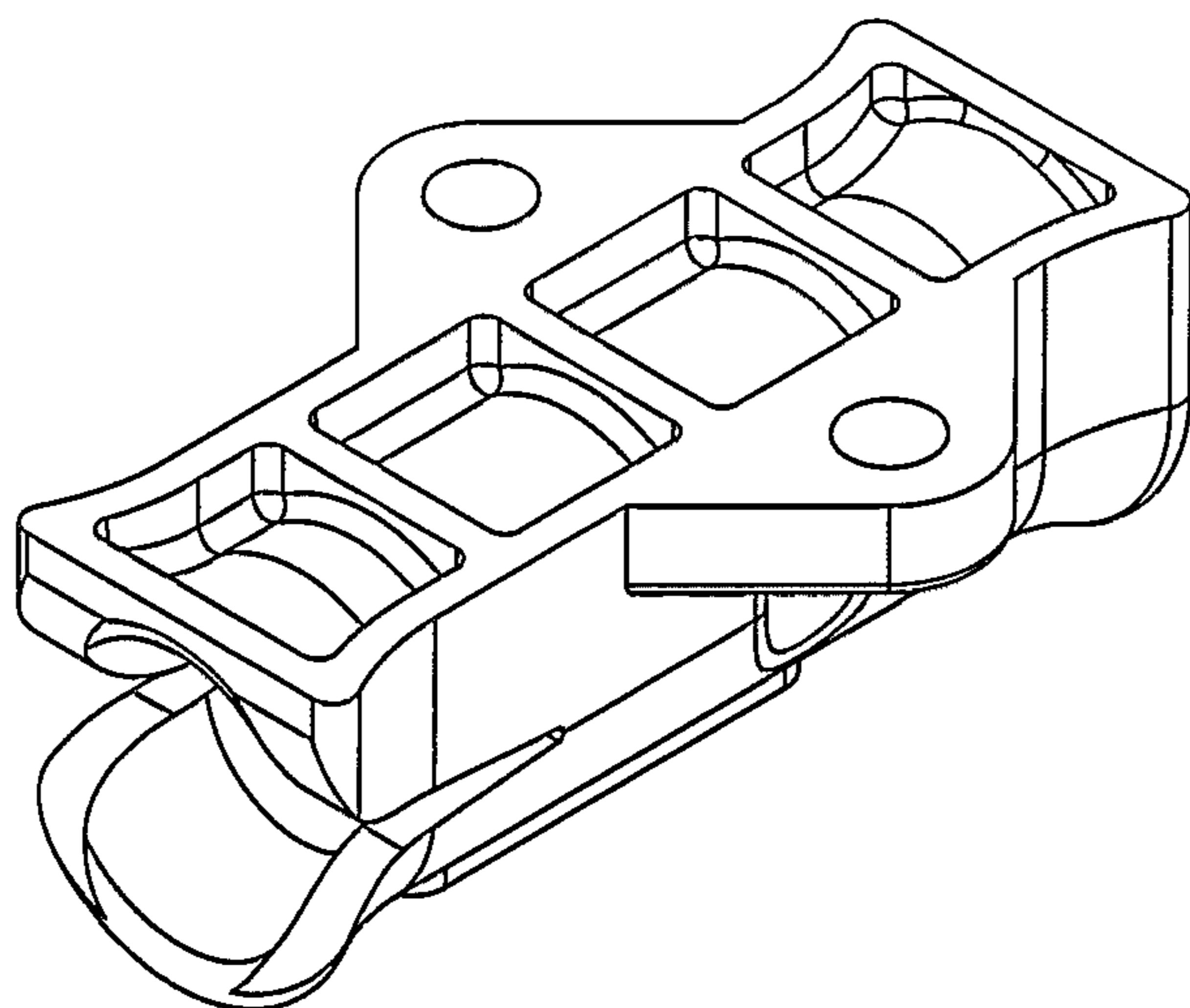

FIG. 5

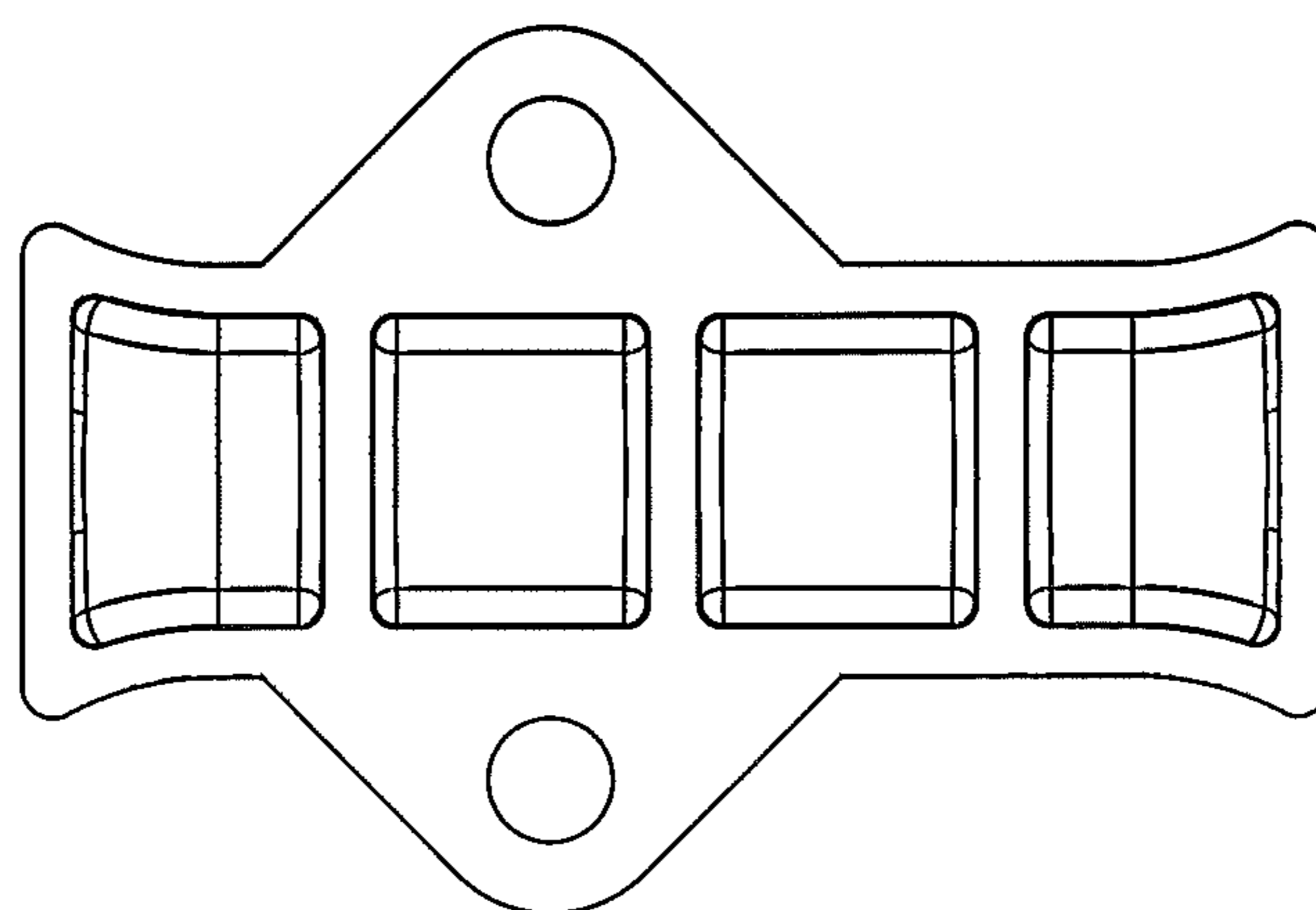

FIG. 6