



US00D711646S

(12) **United States Design Patent**
Ke

(10) **Patent No.:** **US D711,646 S**

(45) **Date of Patent:** **** Aug. 26, 2014**

(54) **ARTICLE OF LUGGAGE**

(71) Applicant: **Shanghai Damao Luggage Co., Ltd.**,
Shanghai (CN)

(72) Inventor: **Huizi Ke**, Shanghai (CN)

(73) Assignee: **Shanghai Damao Luggage Co., Ltd.**,
Shanghai (CN)

(**) Term: **14 Years**

(21) Appl. No.: **29/449,552**

(22) Filed: **Mar. 15, 2013**

(51) **LOC (10) Cl.** **03-01**

(52) **U.S. Cl.**
USPC **D3/279; D3/289**

(58) **Field of Classification Search**
CPC **A44B 19/34–19/346**
USPC **D3/272, 276, 278, 279, 273, 274, 281,**
D3/289, 321; 190/100–127, 37, 39, 18 A;
24/396–398, 393

See application file for complete search history.

(56) **References Cited**

U.S. PATENT DOCUMENTS

5,417,249	A *	5/1995	Kato	139/384 B
D403,859	S *	1/1999	Grona	D3/278
D587,902	S *	3/2009	Yoneno	D3/279
D659,395	S *	5/2012	Sijmons	D3/279
D684,363	S *	6/2013	Wanders	D3/276
2005/0034284	A1 *	2/2005	Yu	24/397

* cited by examiner

Primary Examiner — Jennifer Rivard

(74) *Attorney, Agent, or Firm* — Brown & Michaels, PC

(57) **CLAIM**

The ornamental design for an article of luggage, as shown and described.

DESCRIPTION

FIG. 1 is a front view of the article of luggage.
 FIG. 2 is a back view of the article of luggage.
 FIG. 3 is a left side view of the article of luggage, in a first state.
 FIG. 4 is a detail from the area enclosed by an oval in FIG. 3.
 FIG. 5 is a right side view of the article of luggage, in the first state.
 FIG. 6 is a bottom view of the article of luggage, in the first state.
 FIG. 7 is a top view of the article of luggage, in the first state.
 FIG. 8 is a perspective view of the article of luggage, in the first state.
 FIG. 9 is a bottom perspective view of the article of luggage, in the first state.
 FIG. 10 is a left side view of the article of luggage, in a second state.
 FIG. 11 is a detail from the area enclosed by an oval in FIG. 10.
 FIG. 12 is a right side view of the article of luggage, in the second state.
 FIG. 13 is a bottom view of the article of luggage, in the second state.
 FIG. 14 is a top view of the article of luggage, in the second state.
 FIG. 15 is a perspective view of the article of luggage, in the second state; and,
 FIG. 16 is a bottom perspective view of the article of luggage, in the second state.
 The article of luggage is capable of expanding from a first state to a second, expanded state. Therefore, in the drawing the article of luggage is shown in each of the two states—FIGS. 3-9 show the article of luggage in the first state, and FIGS. 10-16 show the article of luggage in the second state. FIGS. 1 and 2 illustrate the front and back views for both states.

1 Claim, 16 Drawing Sheets

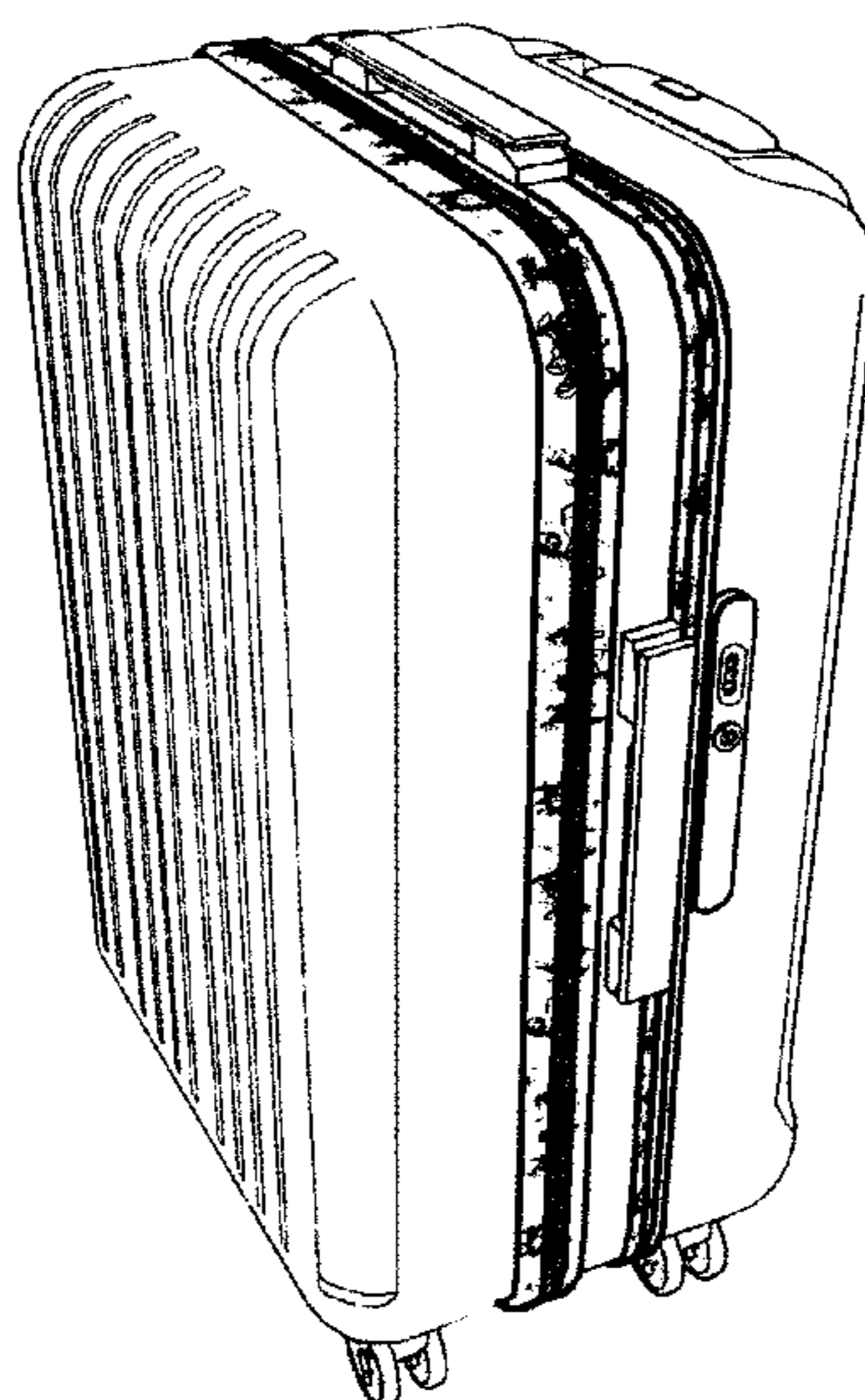

Fig. 1

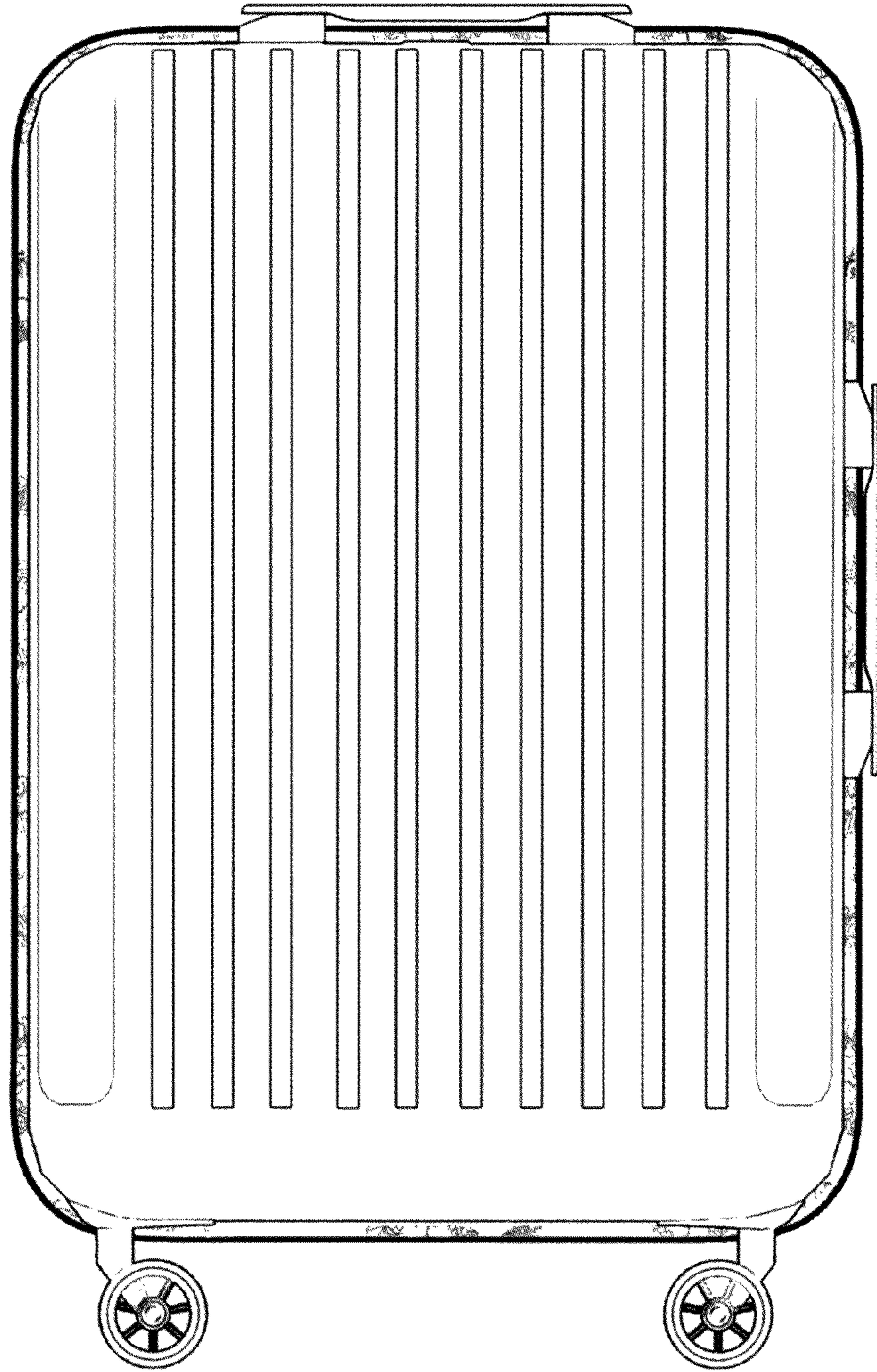

Fig. 2

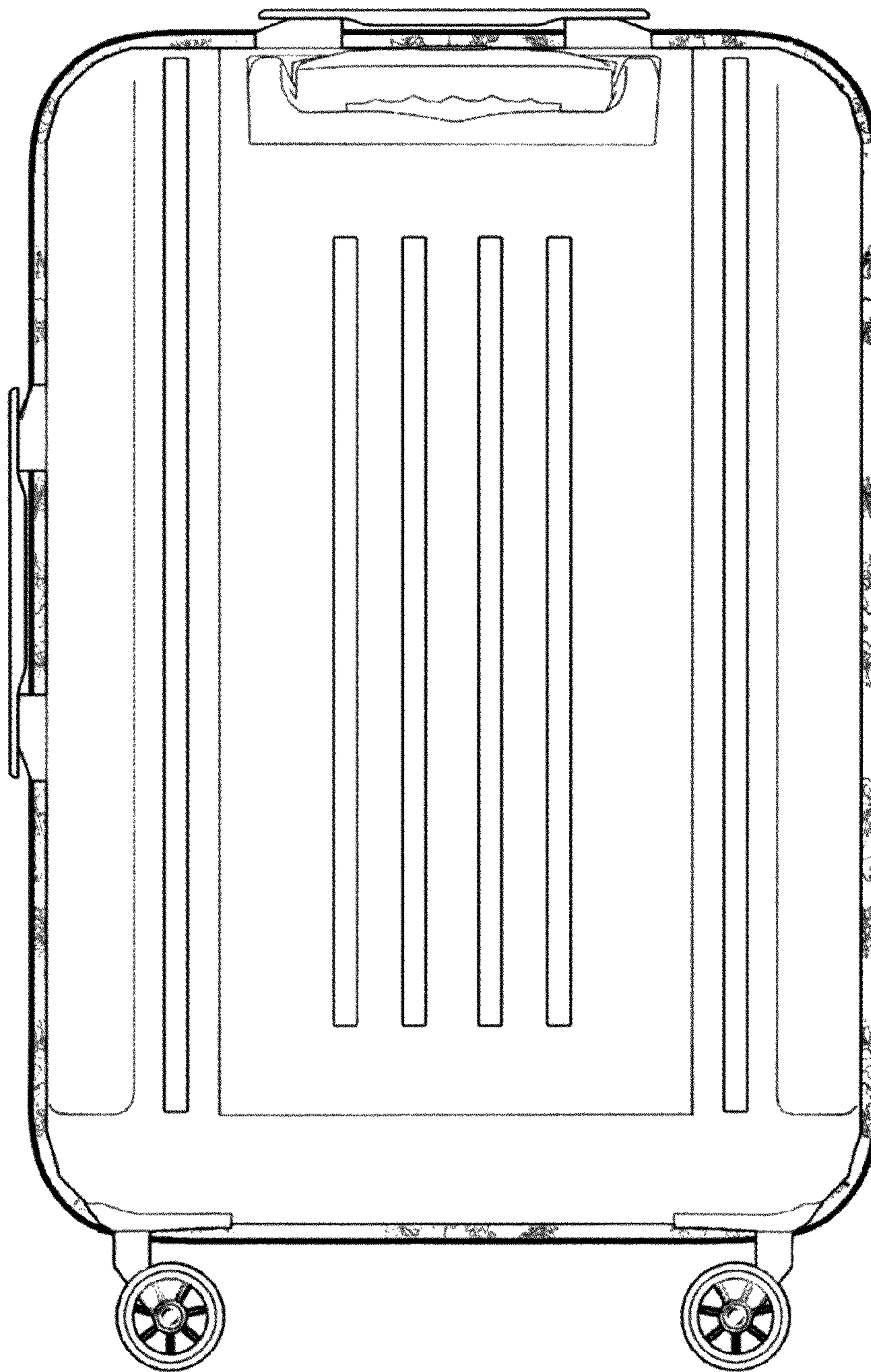

Fig. 3

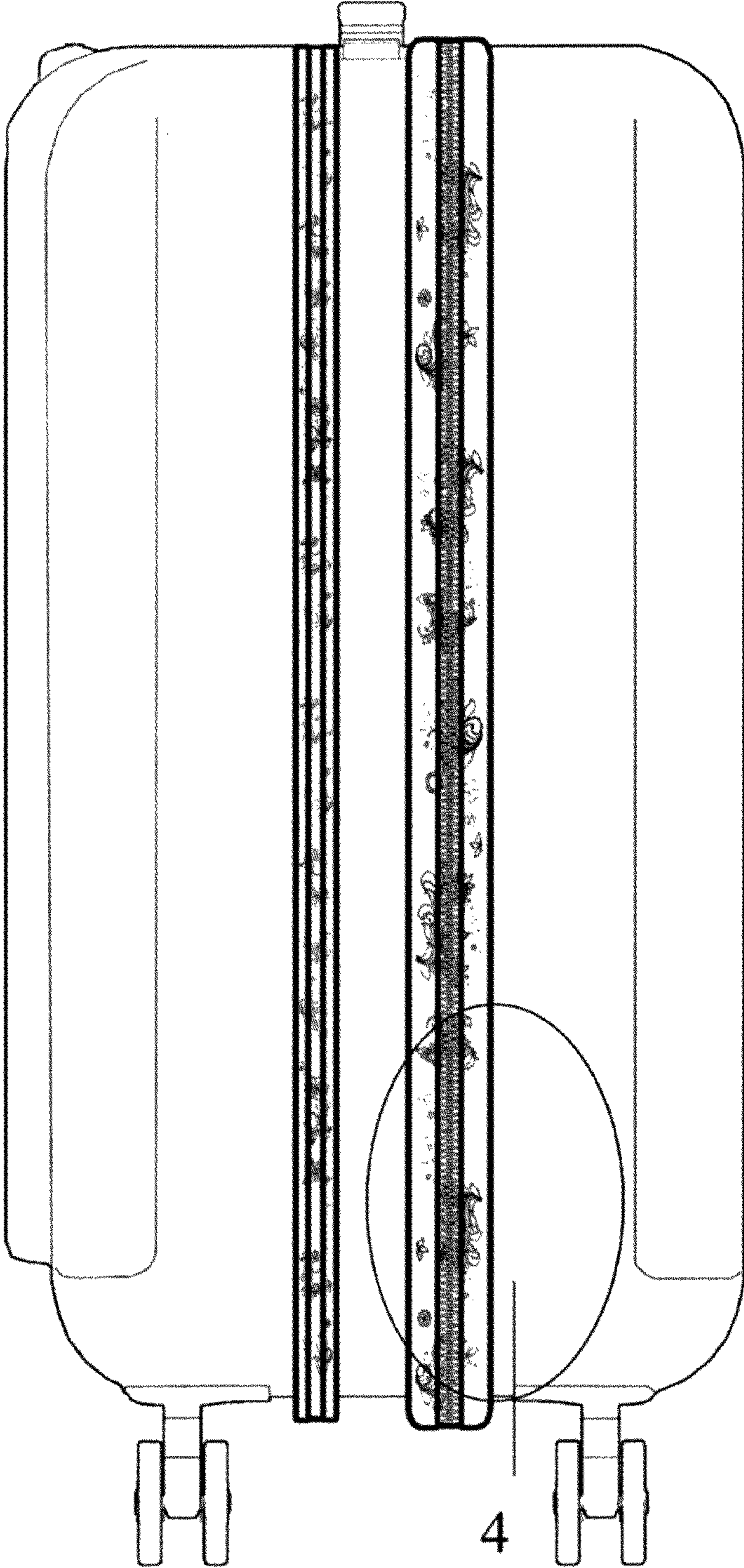

Fig. 4

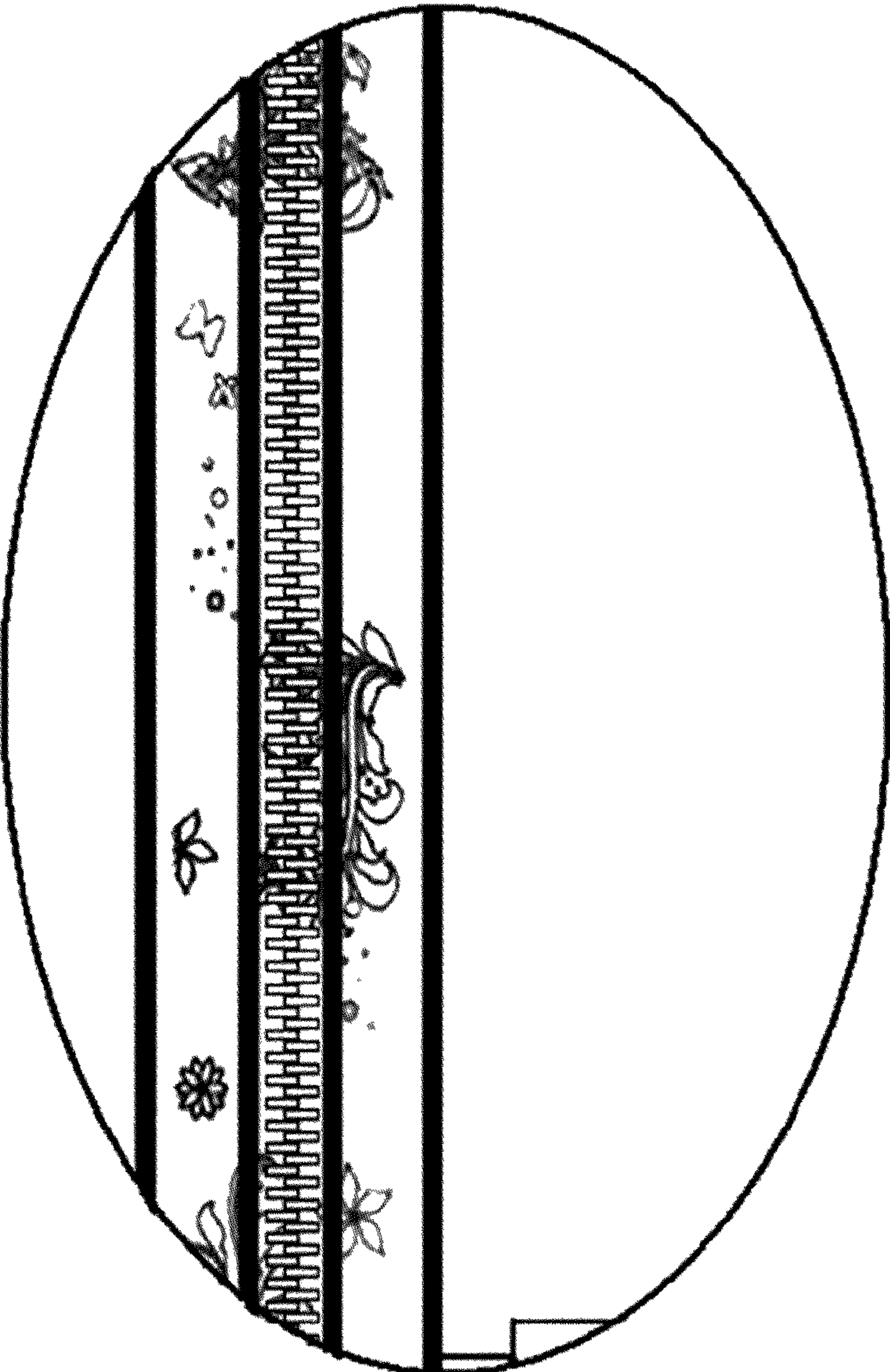

Fig. 5

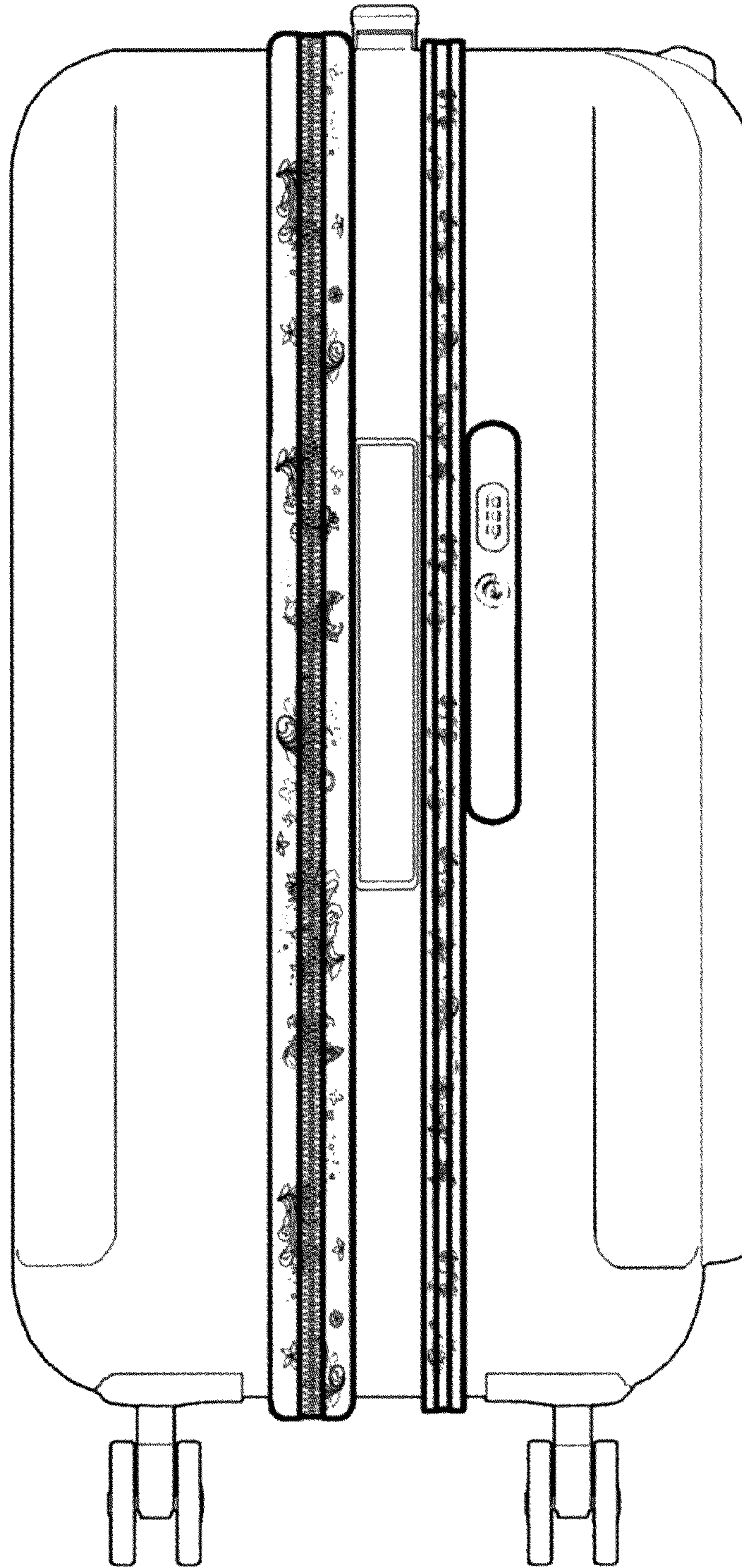

Fig. 6

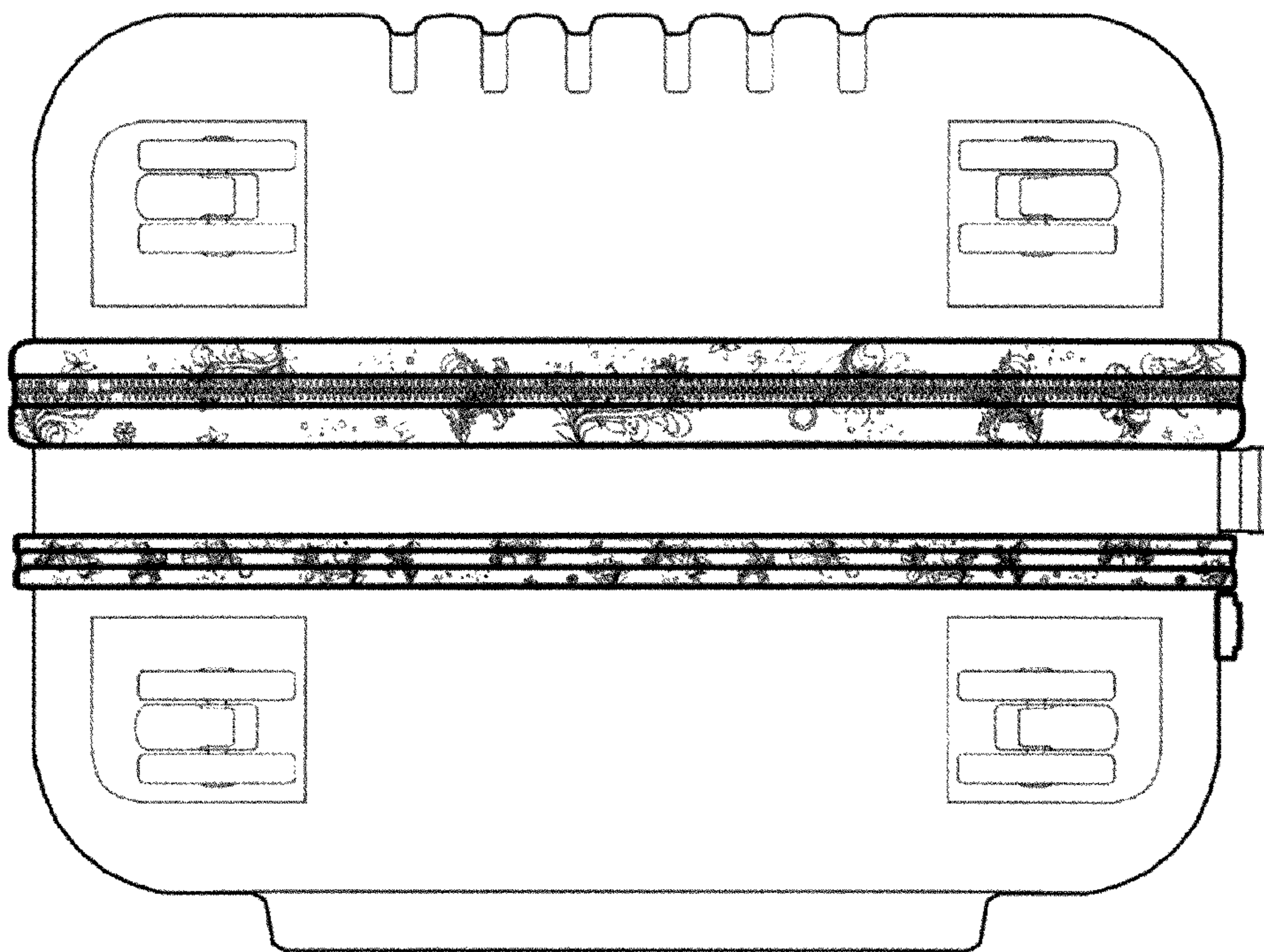

Fig. 7

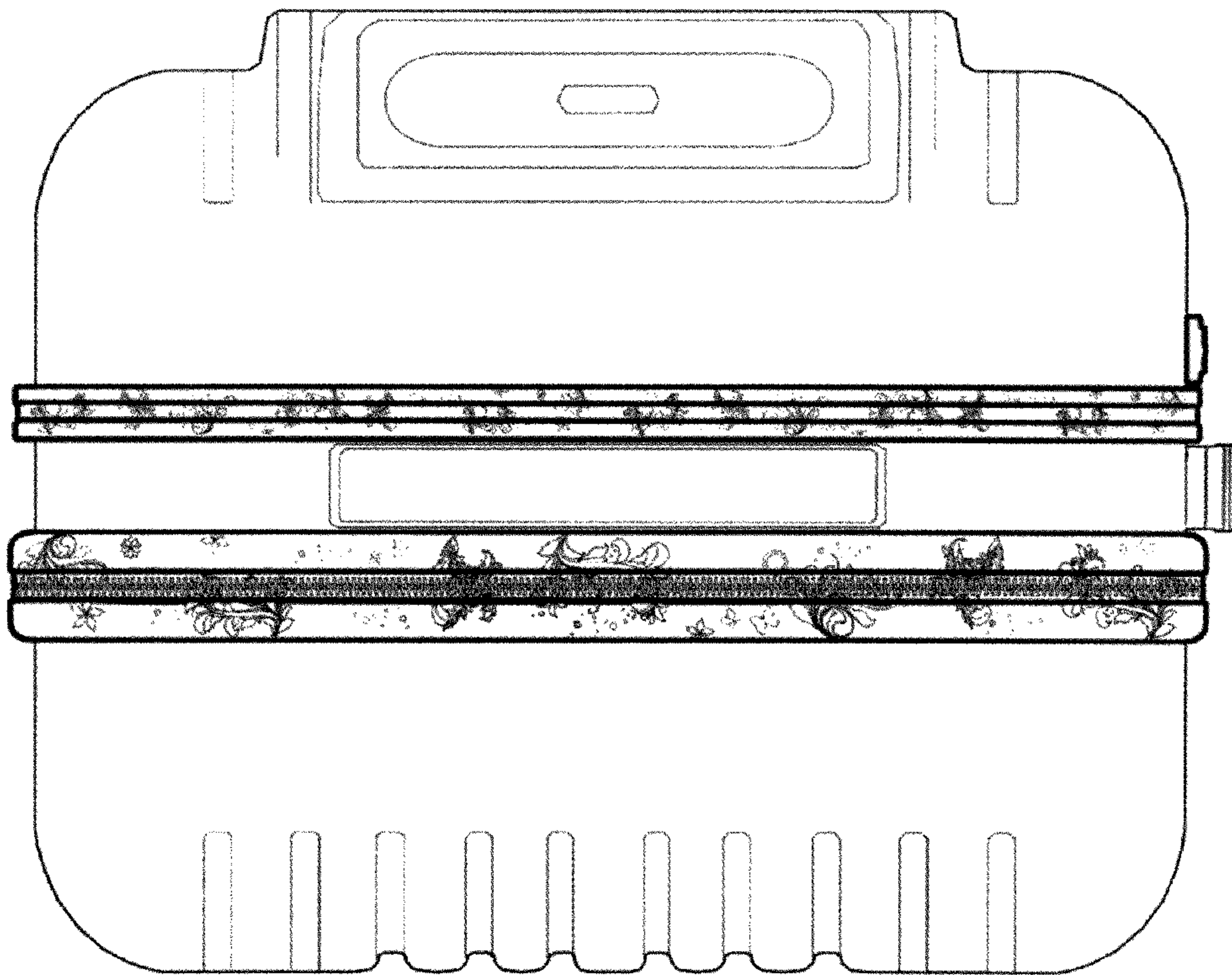

Fig. 8

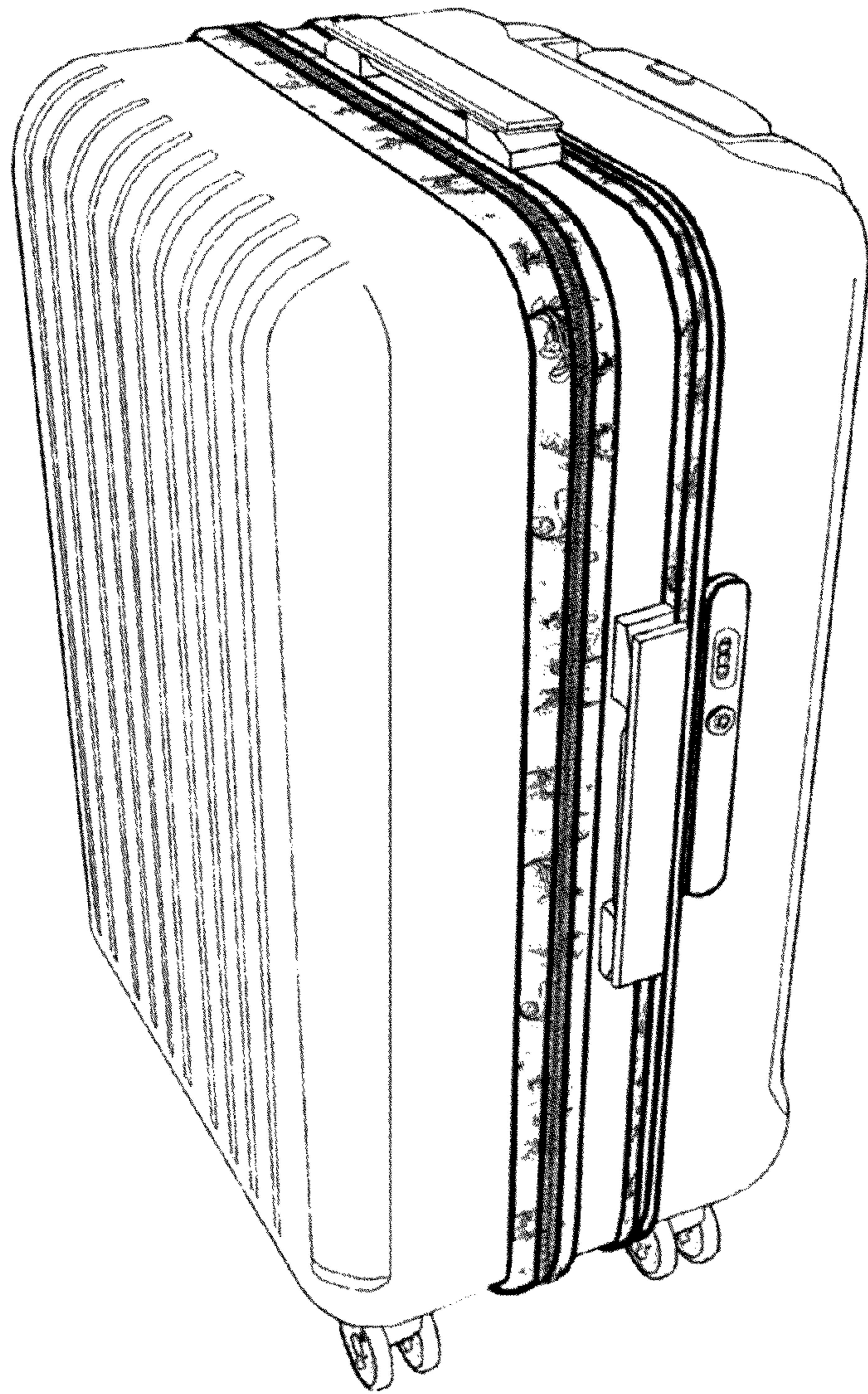

Fig. 9

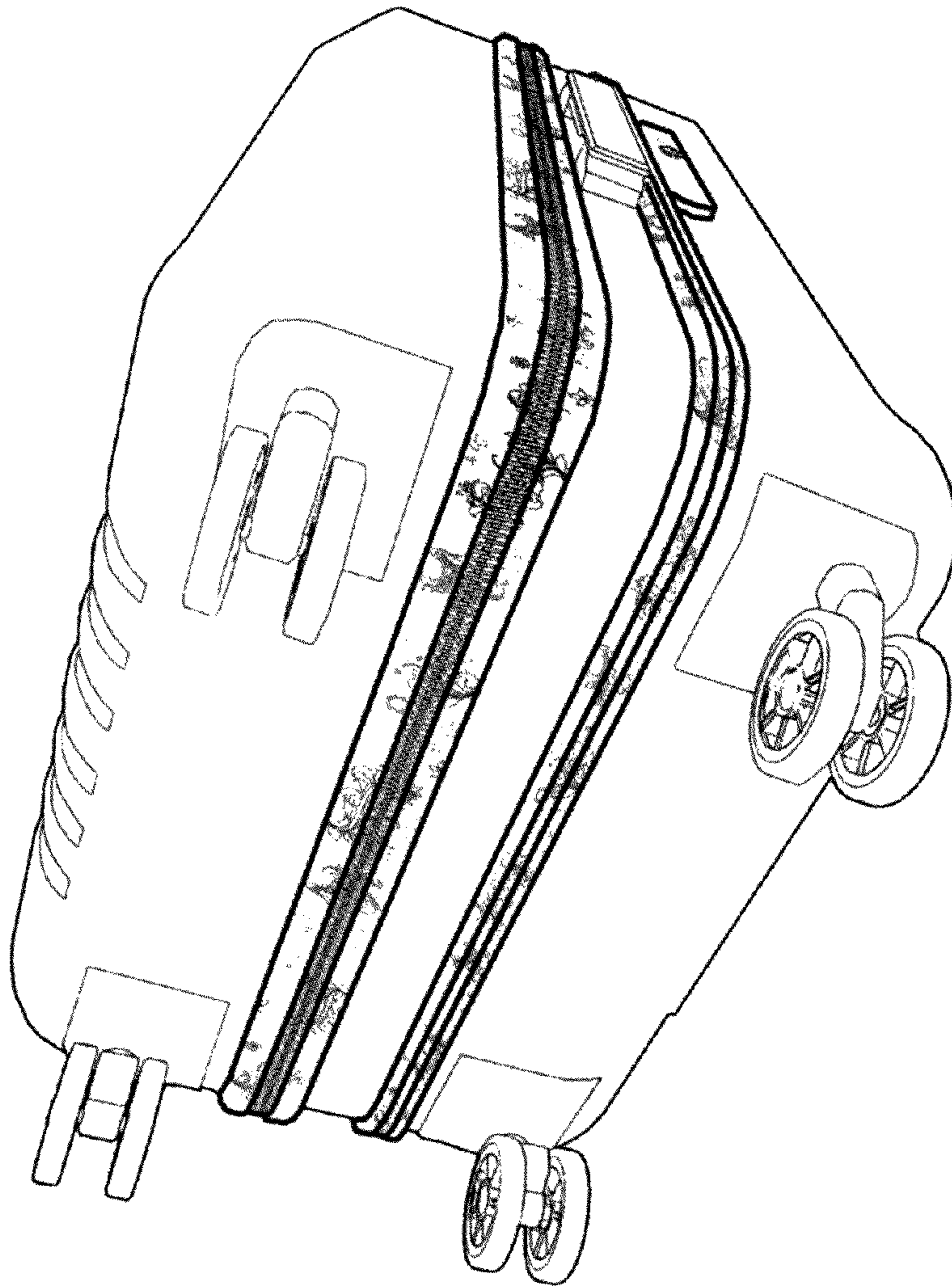

Fig. 10

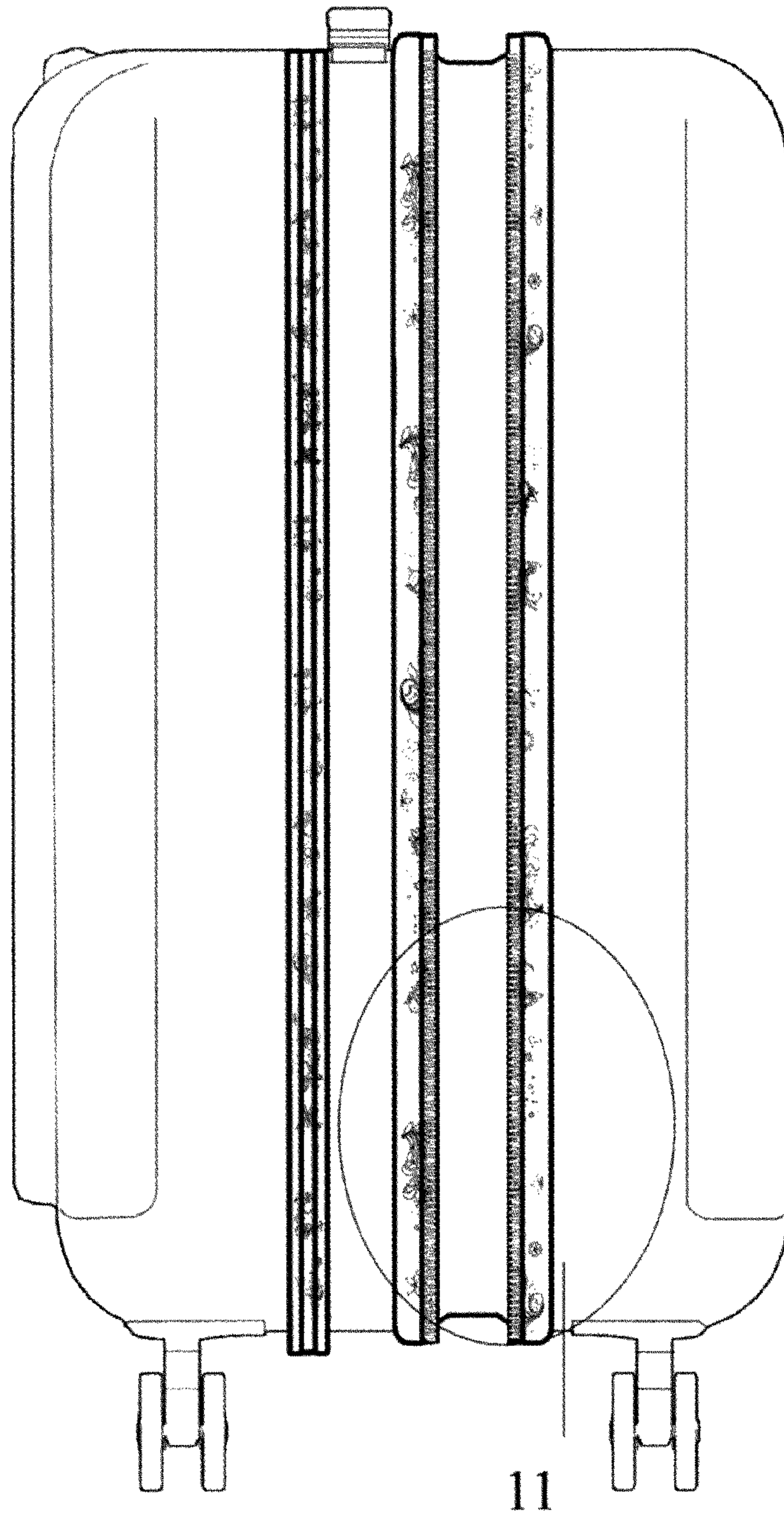

Fig. 11

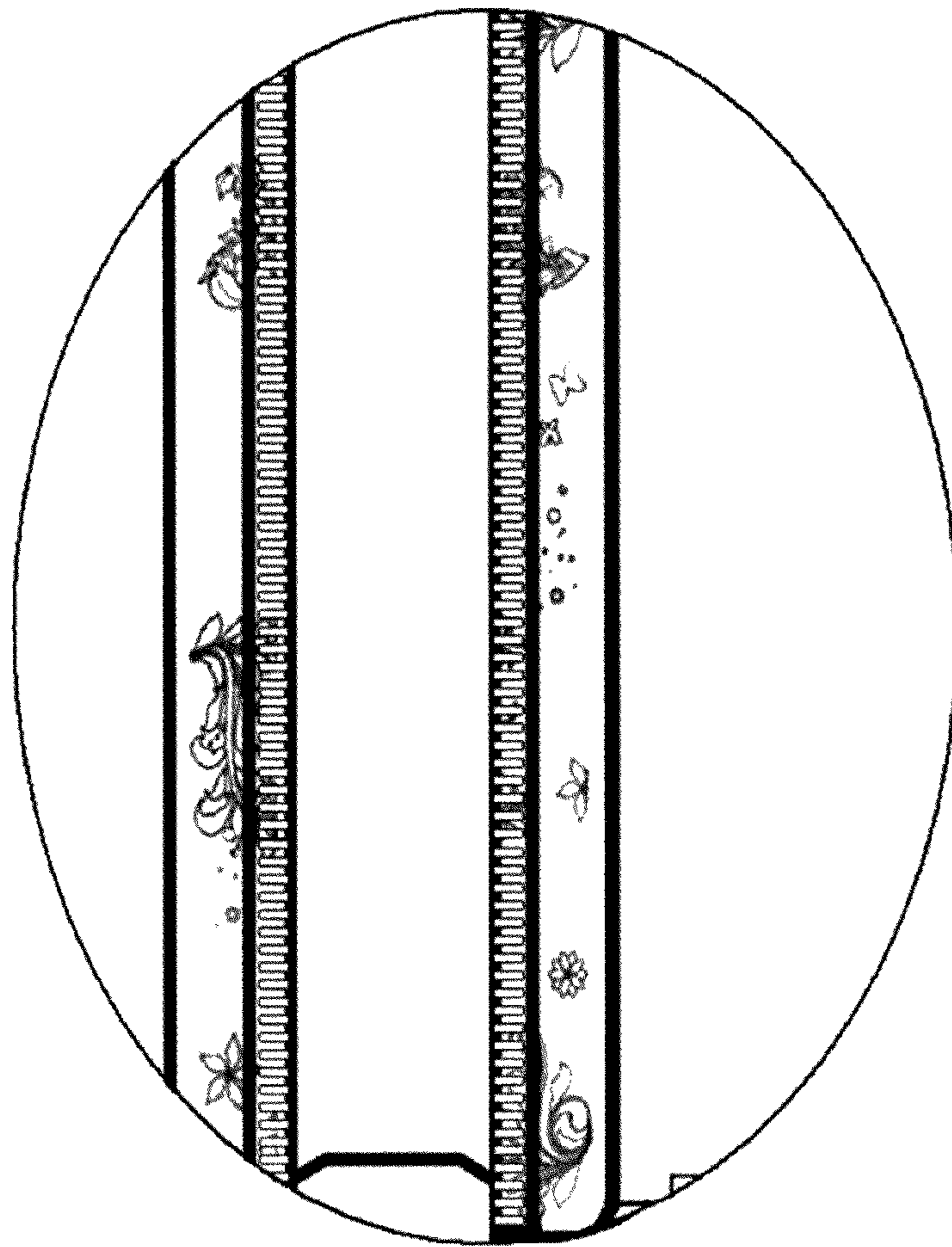

Fig. 12

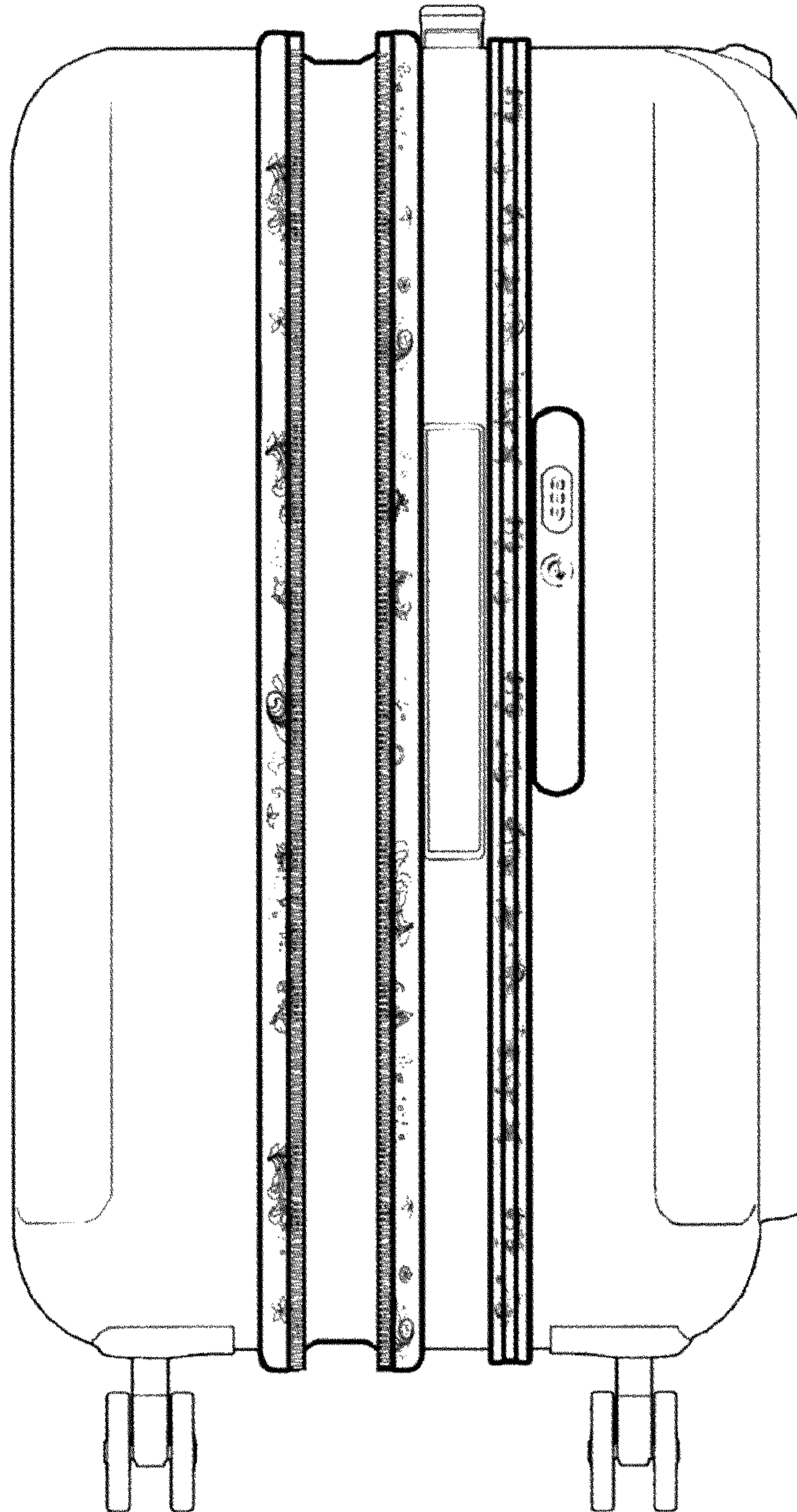

Fig. 13

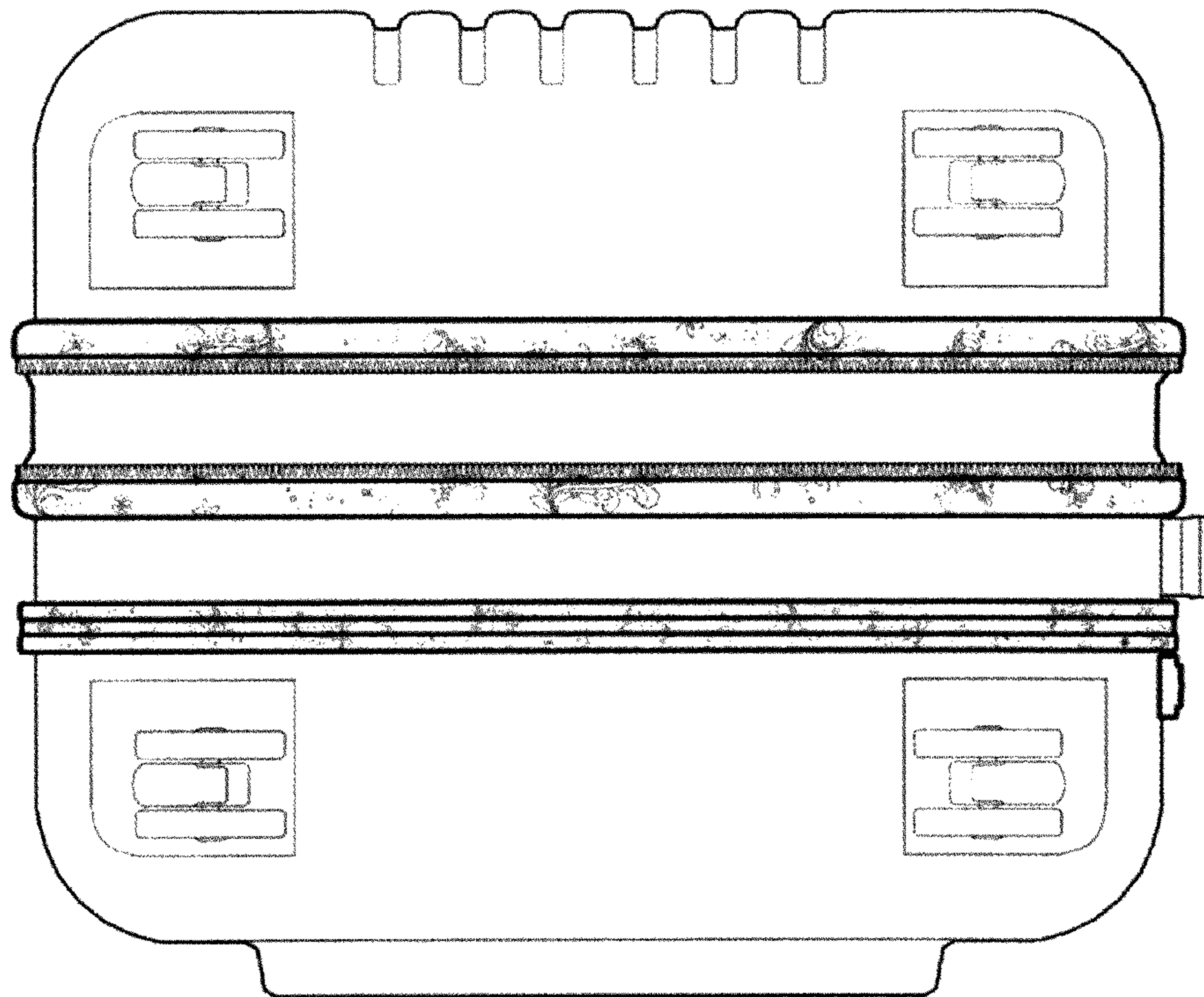

Fig. 14

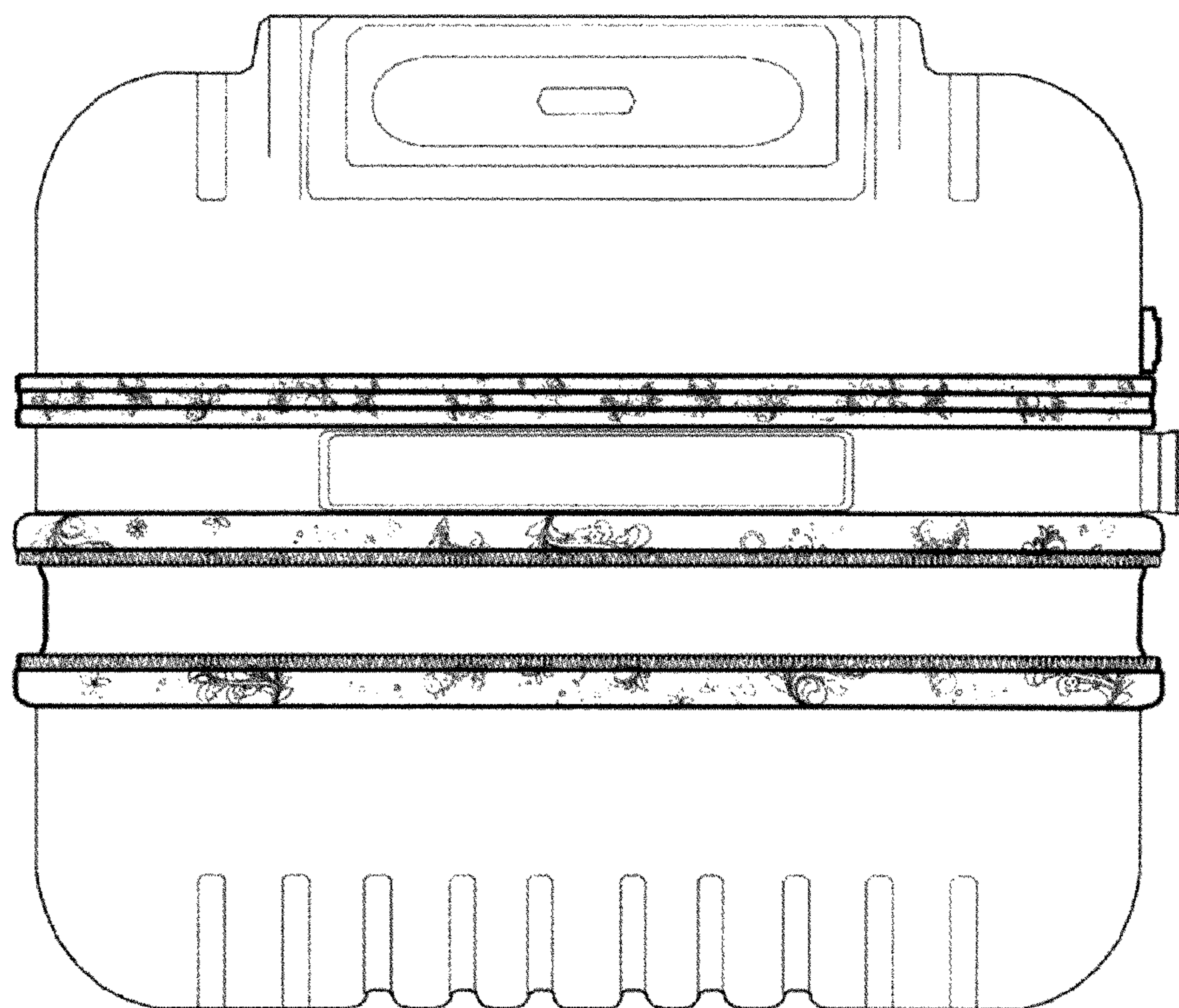

Fig. 15

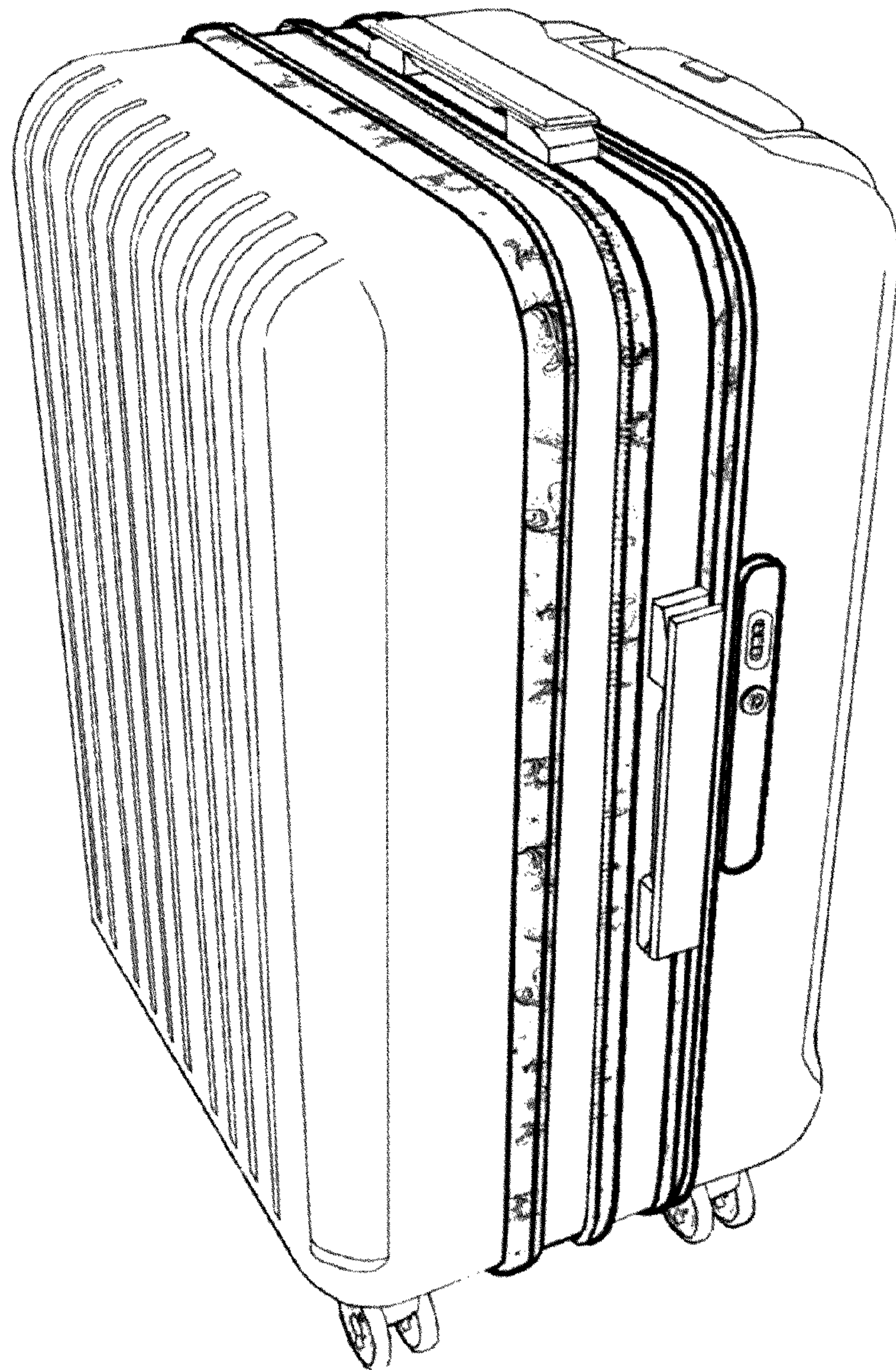

Fig. 16

