



US00D711563S

(12) **United States Design Patent**
Dickman et al.

(10) **Patent No.:** **US D711,563 S**
(45) **Date of Patent:** **** Aug. 19, 2014**

(54) **HEADLIGHT FOR A VEHICLE**

(75) Inventors: **Ryan Dickman**, Portland, OR (US);
Michael Gatza, Portland, OR (US);
Dieter Rohkohl, Portland, OR (US);
Justin Yee, Portland, OR (US)

(73) Assignee: **Daimler AG**, Stuttgart (DE)

(**) Term: **14 Years**

(21) Appl. No.: **29/432,205**

(22) Filed: **Sep. 14, 2012**

(30) **Foreign Application Priority Data**

Mar. 16, 2012 (EM) 002009969-0002

(51) **LOC (10) CL.** **26-06**

(52) **U.S. CL.**
USPC **D26/28**

(58) **Field of Classification Search**
USPC D26/28-36, 139; 362/459-468,
362/475-478, 485-487
See application file for complete search history.

(56) **References Cited**

U.S. PATENT DOCUMENTS

D470,954 S *	2/2003	Isayama et al.	D26/28
D472,656 S *	4/2003	Pfeiffer et al.	D26/28
D518,197 S *	3/2006	Osawa	D26/28
D526,427 S *	8/2006	Morioka	D26/28
D550,383 S *	9/2007	Asai	D26/28
D691,753 S *	10/2013	Smarslik	D26/28

* cited by examiner

Primary Examiner — Marcus Jackson

(74) *Attorney, Agent, or Firm* — Crowell & Moring LLP

(57) **CLAIM**

The ornamental design for a headlight for a vehicle, as shown and described.

DESCRIPTION

This application contains subject matter related to the following co-pending U.S. design patent applications: Application Ser. No. 29/432,195, filed herewith and entitled "Vehicle, Toy, and/or Replicas Thereof"; and, Application Ser. No. 29/432,201, filed herewith and entitled "Headlight for a Vehicle".

FIG. 1 is a right perspective view of a first embodiment of a headlight for a vehicle according to our design, the top portion of which is lined for the color amber and the bottom portion of which is lined for the color white;

FIG. 2 is a right perspective view thereof, with the lining for color omitted and shading included only for clarity of illustration;

FIG. 3 is a left perspective view thereof, with the lining for color omitted and shading included only for clarity of illustration; and

FIG. 4 is a front view thereof, with the lining for color omitted and shading included only for clarity of illustration.

FIG. 5 is a left perspective view of a second embodiment of the headlight for a vehicle according to our design, the top portion of which is lined for the color amber and the bottom portion of which is lined for the color white;

FIG. 6 is a left perspective view thereof, with the lining for color omitted and shading included only for clarity of illustration;

FIG. 7 is a right perspective view thereof, with the lining for color omitted and shading included only for clarity of illustration; and,

FIG. 8 is a front view thereof, with the lining for color omitted and shading included only for clarity of illustration.

The broken lines are for illustrative purposes only and form no part of the claimed design. Also enclosed is a set of photographs of an embodiment of the design.

1 Claim, 4 Drawing Sheets

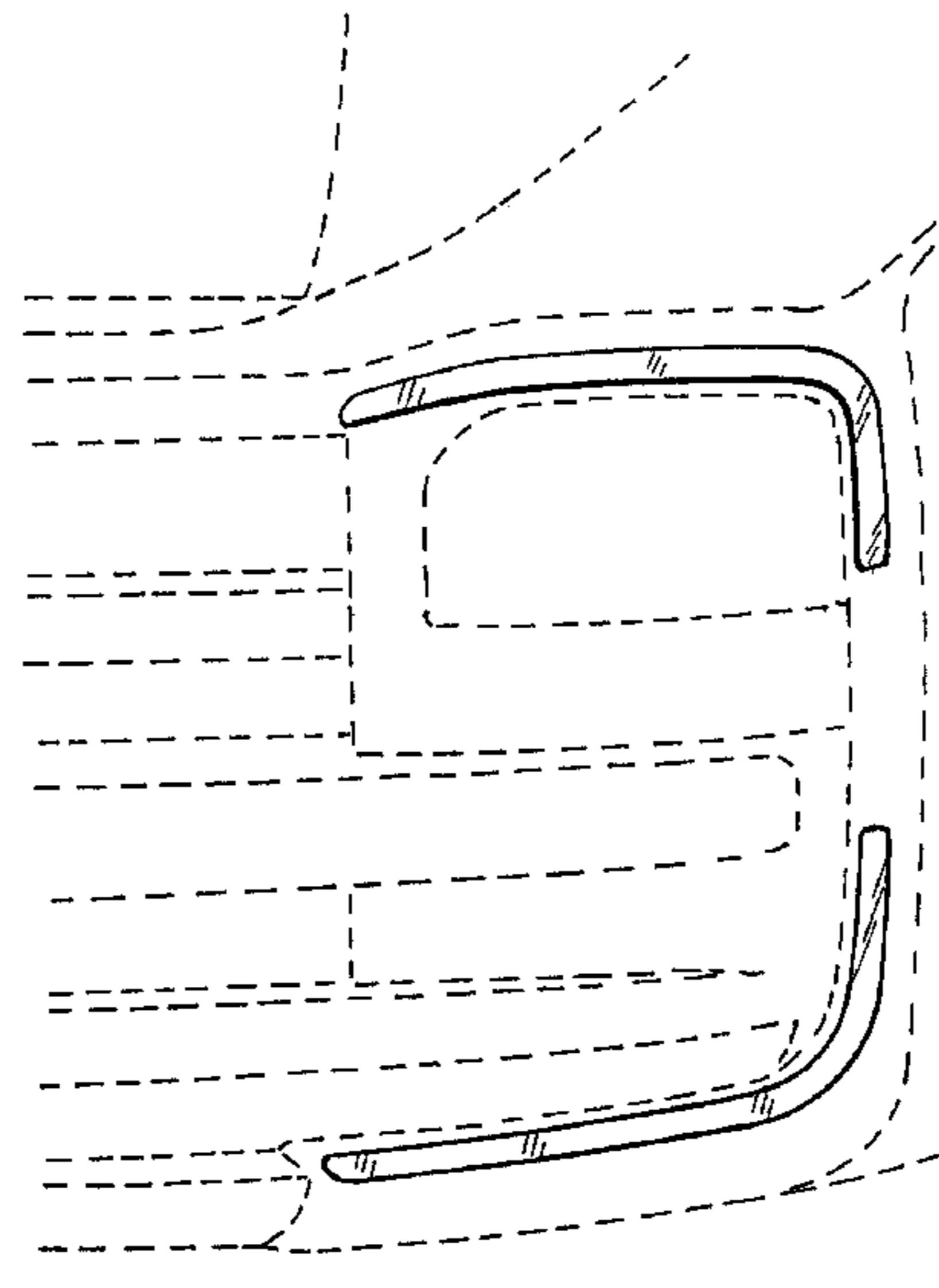
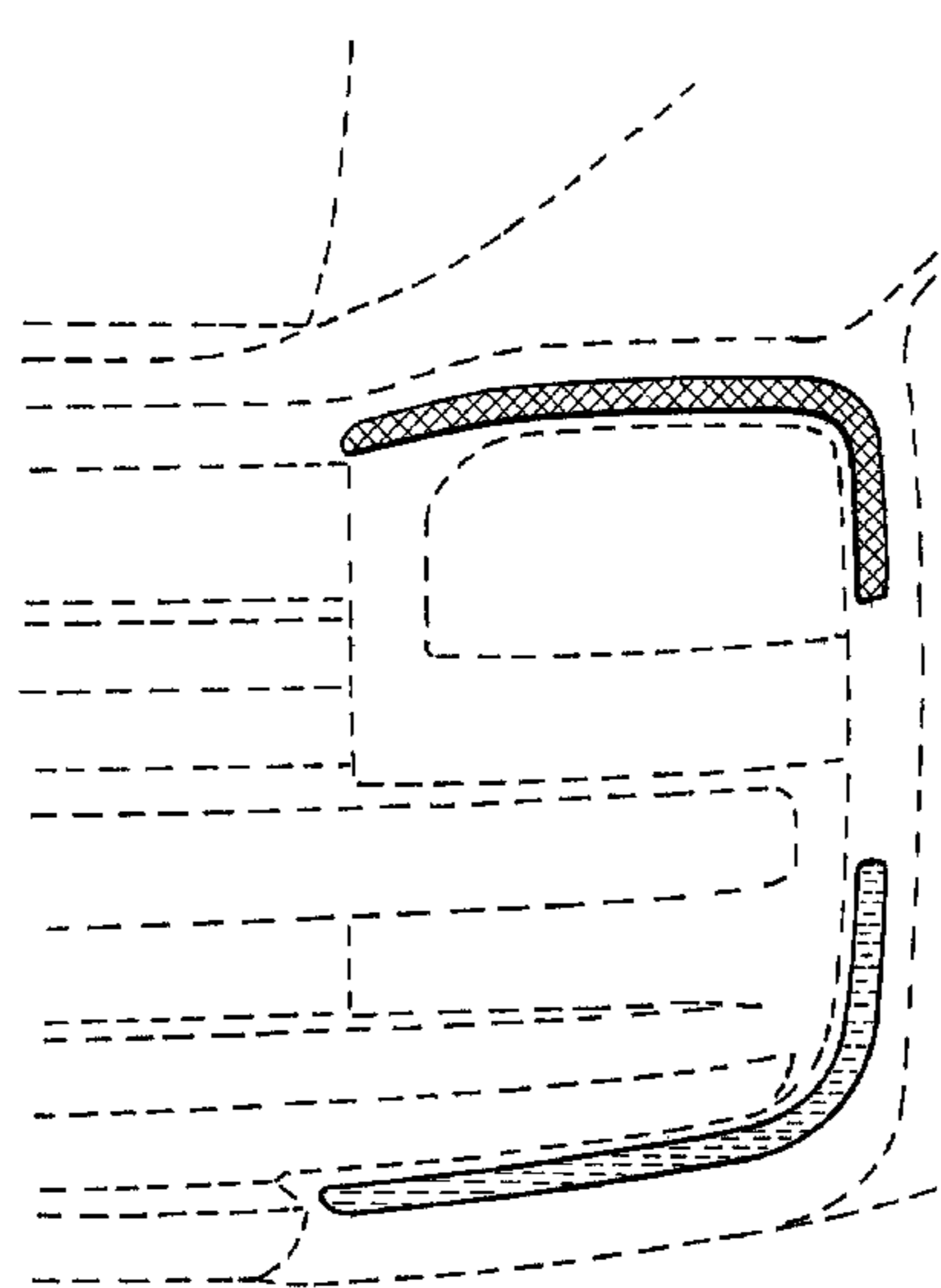

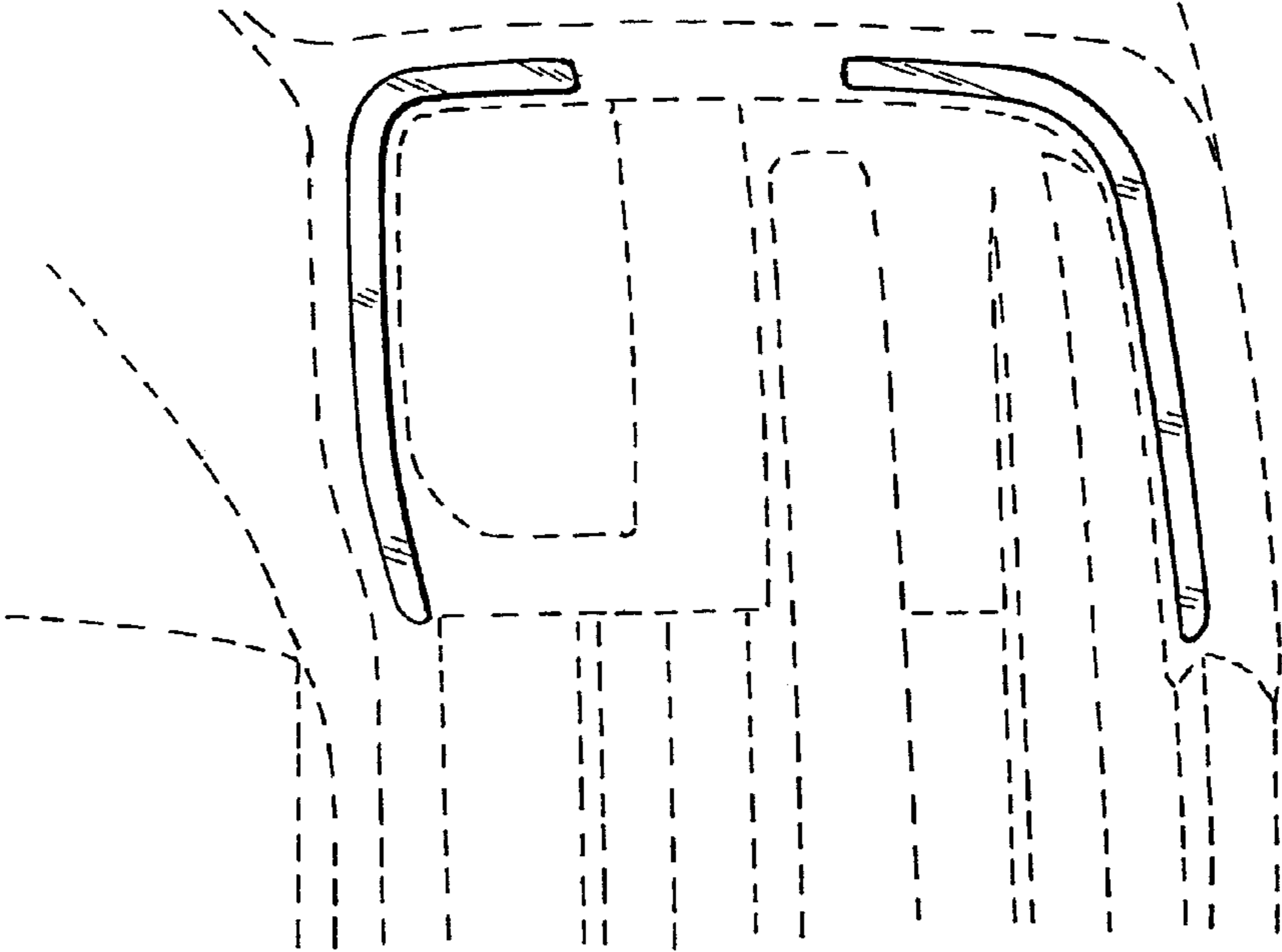

FIG. 1

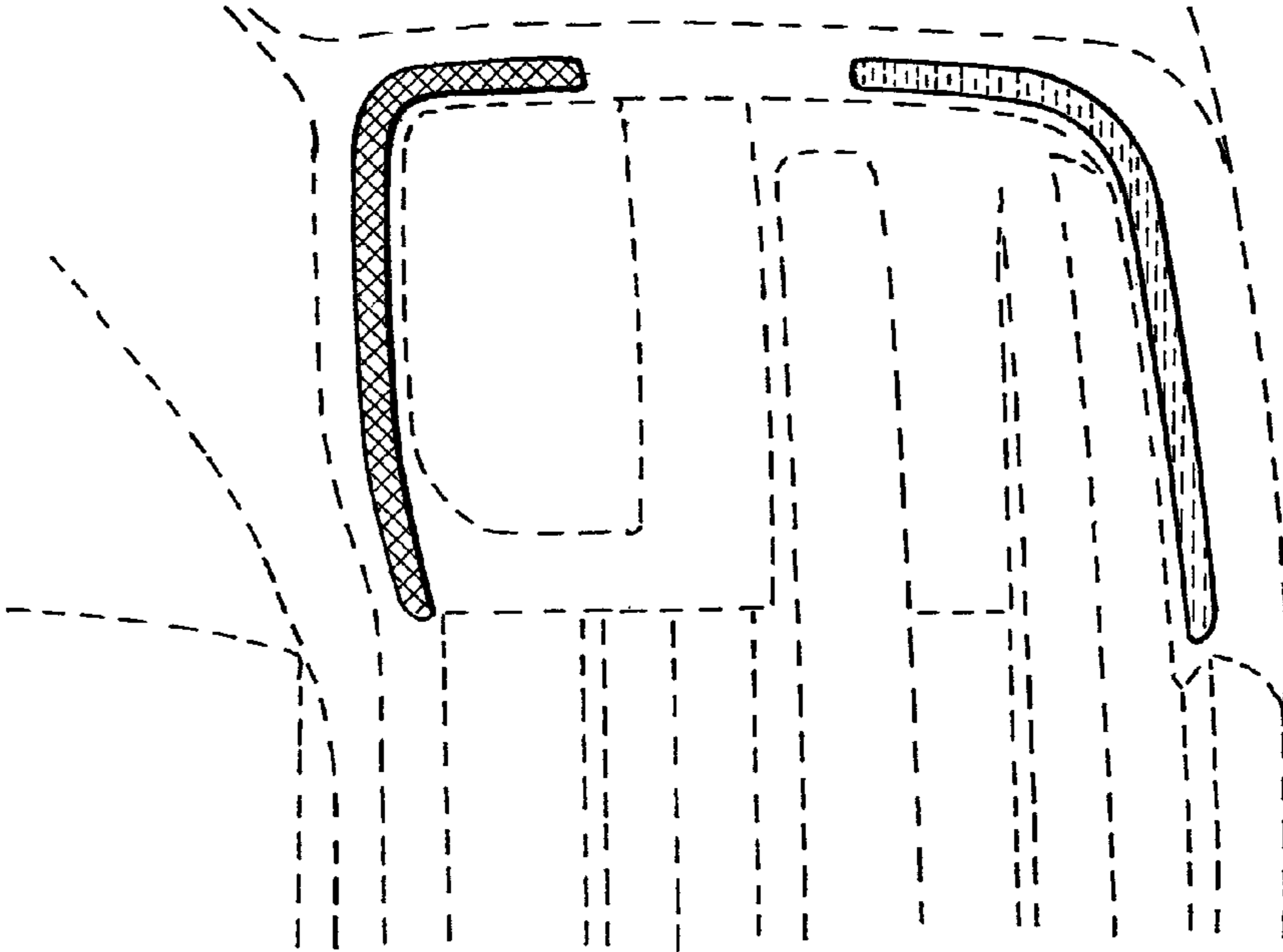

FIG. 2

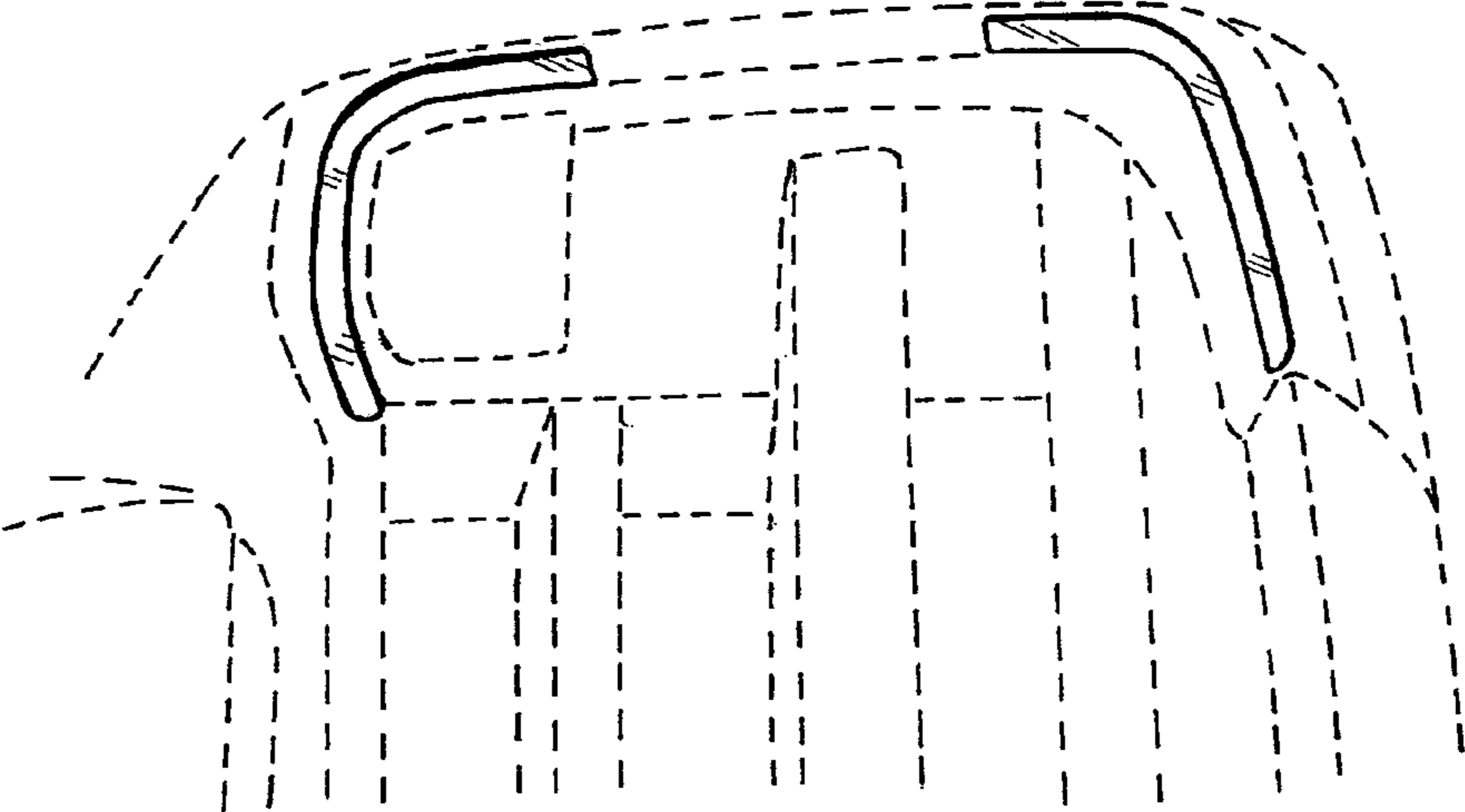

FIG. 4

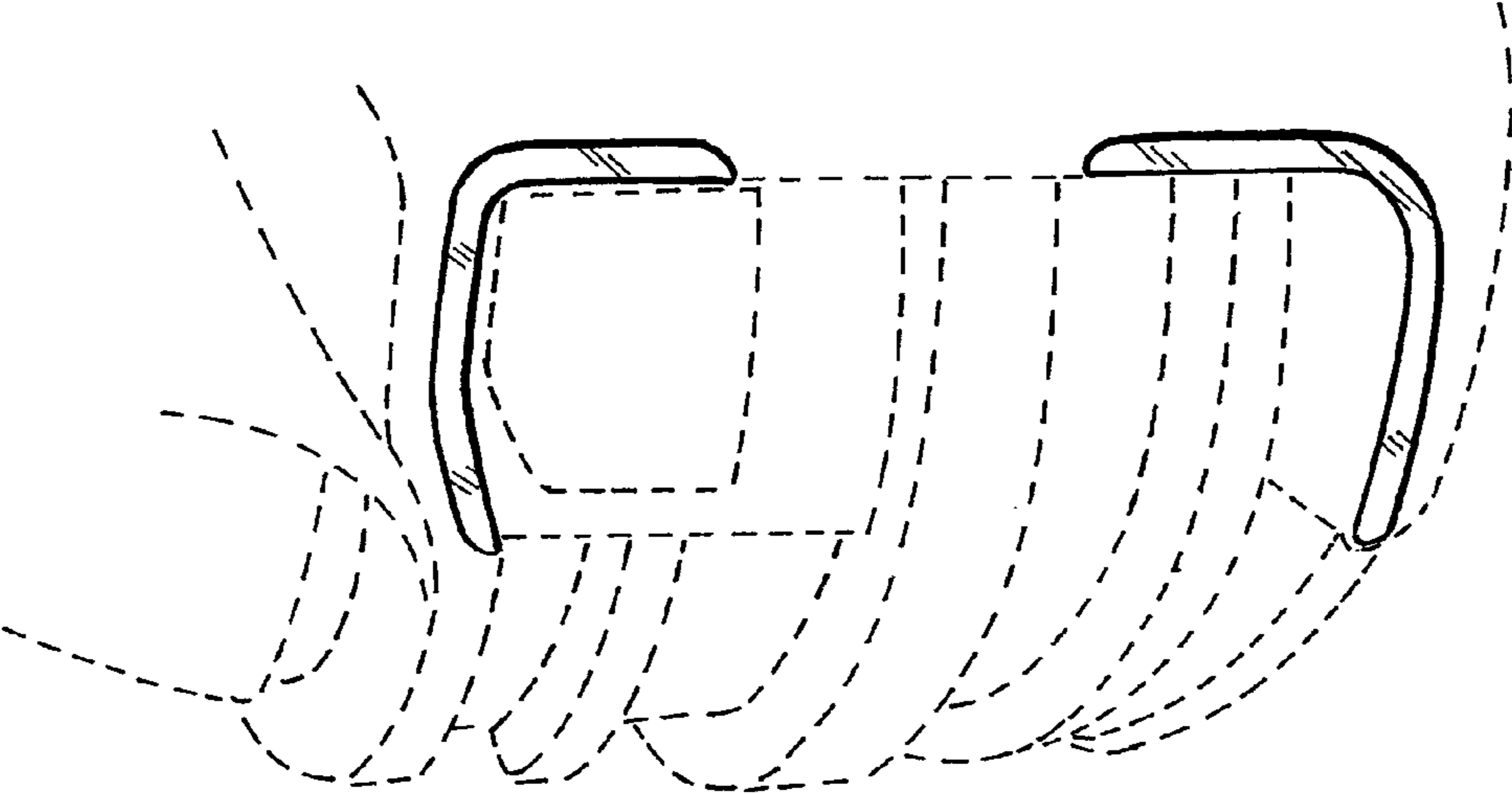

FIG. 3

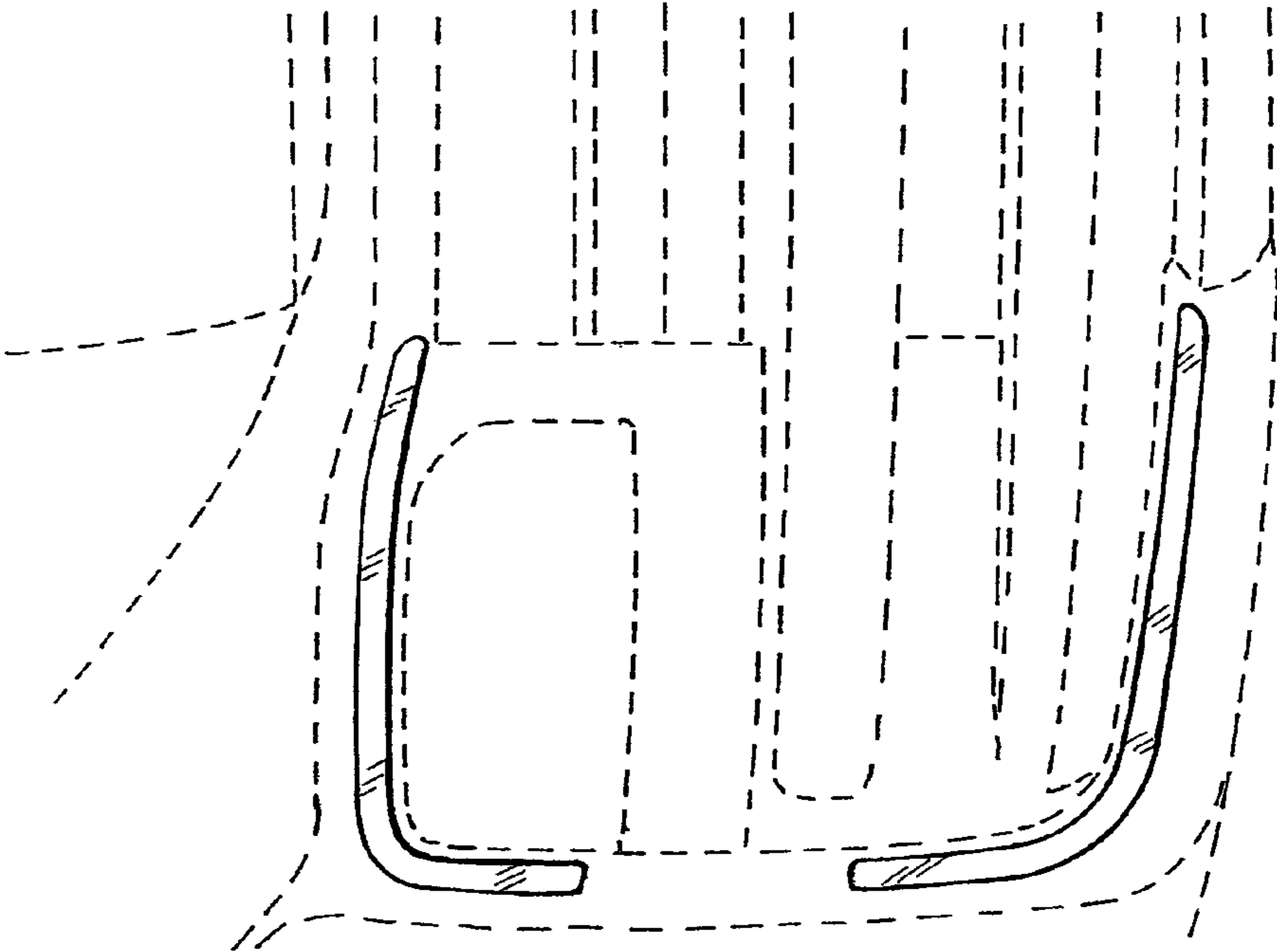

FIG. 5

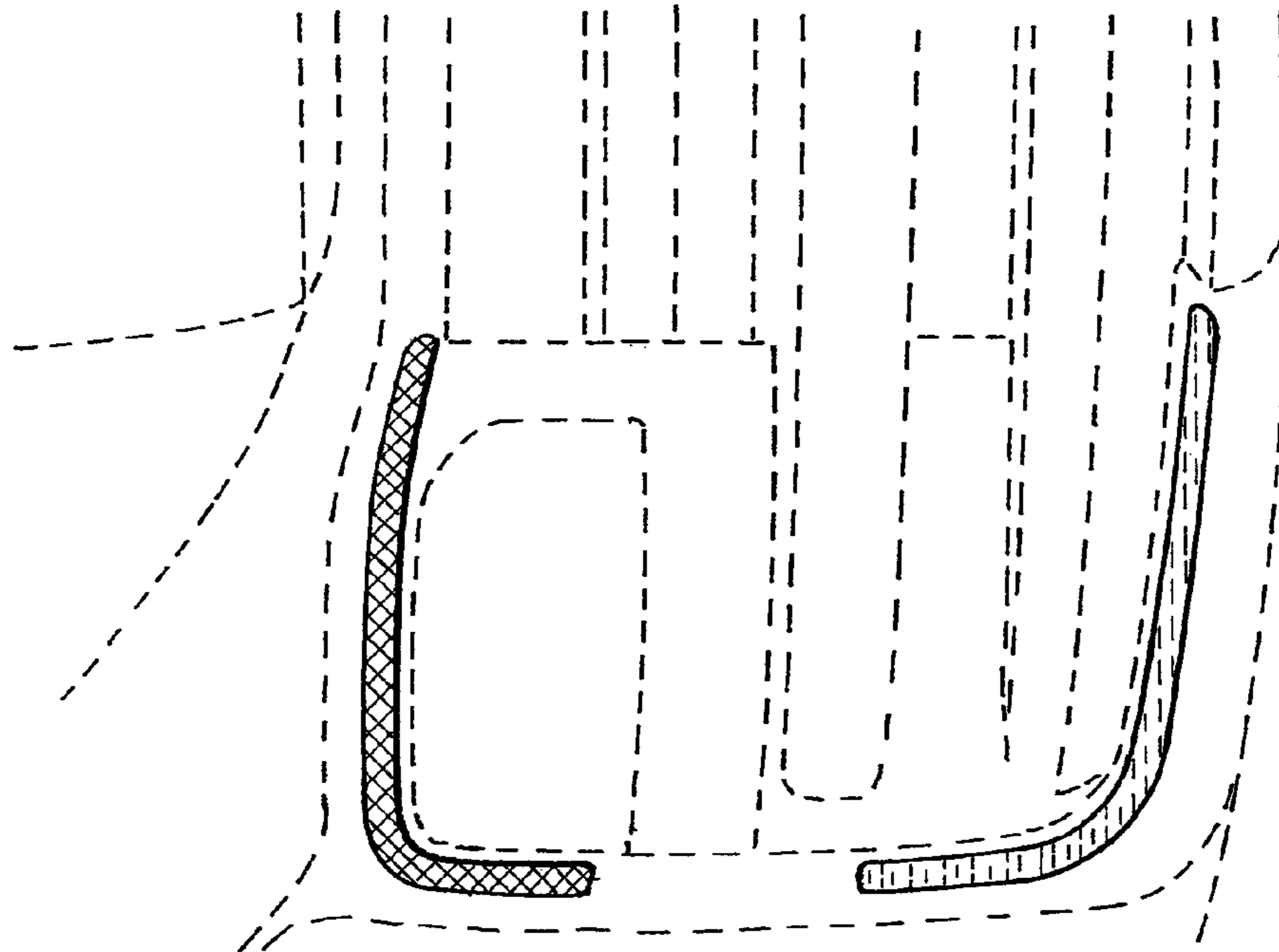

FIG. 6

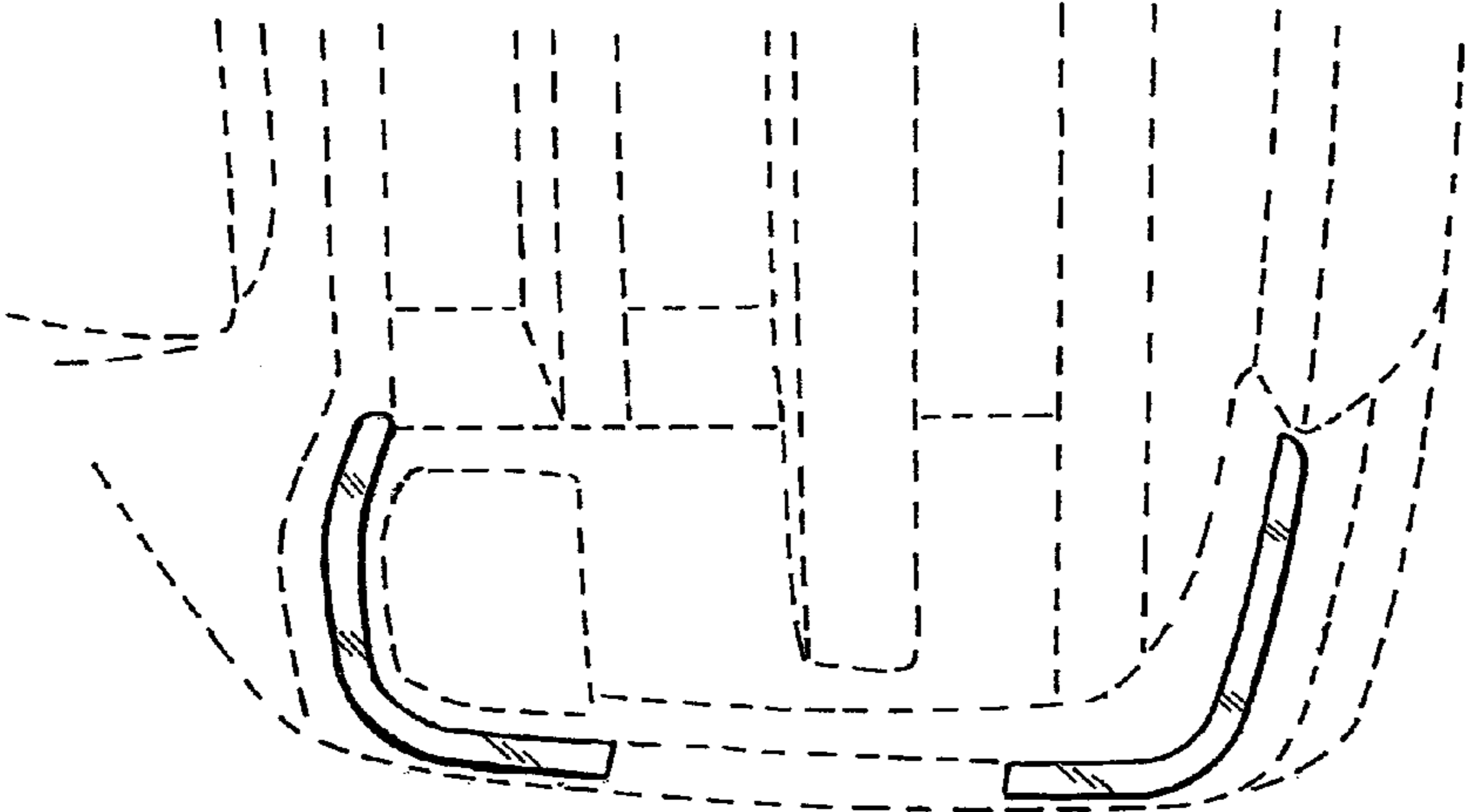

FIG. 8

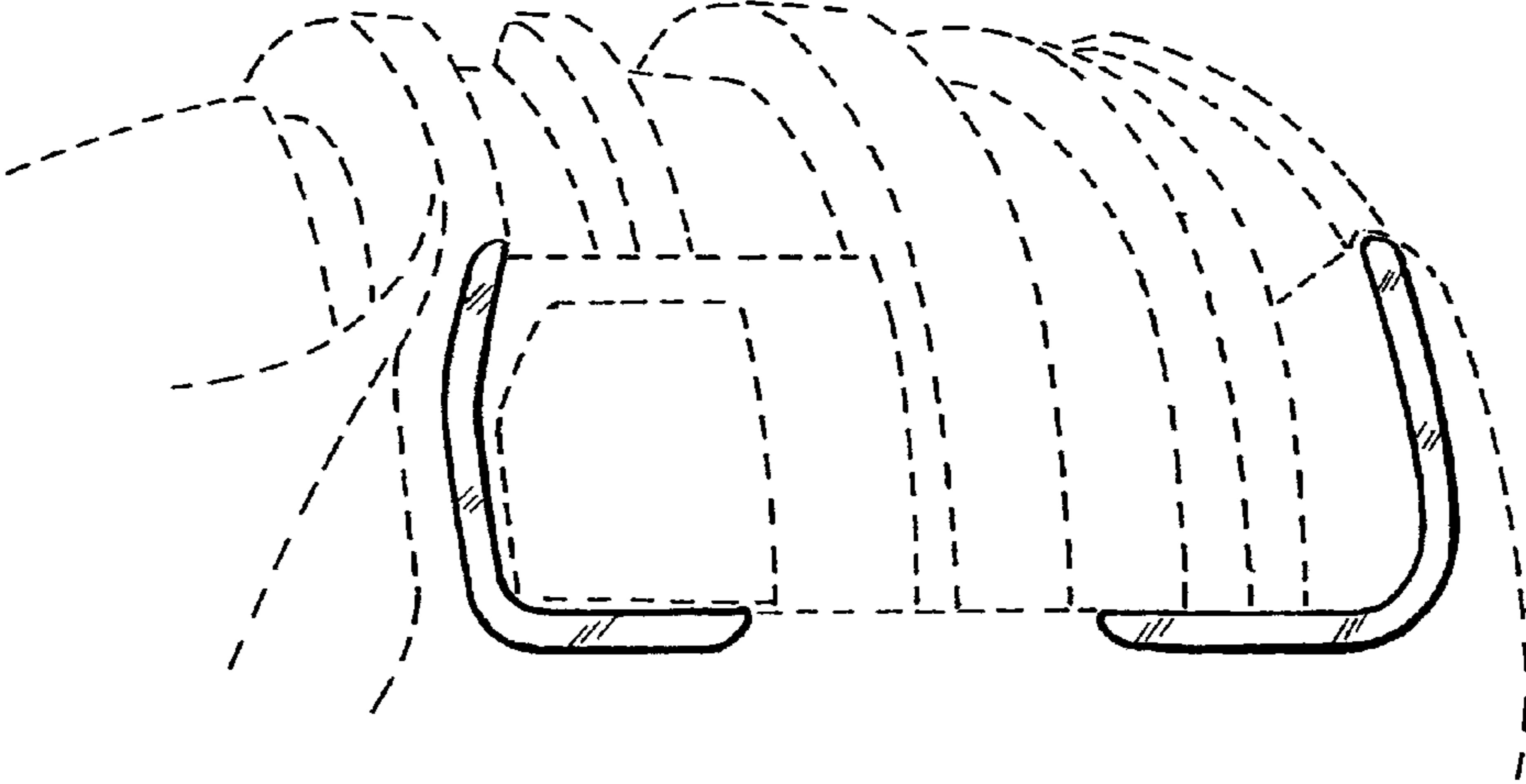

FIG. 7