



US00D710934S

(12) **United States Design Patent**
Petit

(10) **Patent No.:** **US D710,934 S**

(45) **Date of Patent:** **** Aug. 12, 2014**

(54) **REED FOR MUSICAL INSTRUMENTS**

(71) Applicant: **Roger Petit**, Les Pavillons-Sous-Bois
(FR)

(72) Inventor: **Roger Petit**, Les Pavillons-Sous-Bois
(FR)

(**) Term: **14 Years**

(21) Appl. No.: **29/435,614**

(22) Filed: **Oct. 25, 2012**

(30) **Foreign Application Priority Data**

Apr. 26, 2012 (EM) 001325674-0001

(51) **LOC (10) Cl.** **17-02**

(52) **U.S. Cl.**
USPC **D17/13**

(58) **Field of Classification Search**
USPC D17/10, 11, 13, 99; 84/330, 380 R, 381,
84/382, 383 A, 384, 385 R, 386, 387 R,
84/391, 395, 398, 400, 453, 456, 470 R;
D21/405, 411
See application file for complete search history.

(56) **References Cited**

U.S. PATENT DOCUMENTS

1,776,566 A * 9/1930 Newton et al. 84/383 A
2,287,529 A * 6/1942 Maccaferri 84/383 A

2,318,515 A * 5/1943 Nemcek, Jr. 84/383 A
2,492,366 A * 12/1949 Ohnhaus 84/383 A
2,669,897 A * 2/1954 Topor 84/380 R
2,919,617 A * 1/1960 Brillhart 84/383 R
3,165,963 A * 1/1965 Burns 84/383 A
5,227,572 A * 7/1993 Cusack et al. 84/383 A
5,959,226 A * 9/1999 Wygent 84/380 B
6,921,853 B2 * 7/2005 Taillard 84/383 A
7,442,866 B1 * 10/2008 Tsai 84/380 R
2009/0301284 A1 * 12/2009 Legere et al. 84/383 A

* cited by examiner

Primary Examiner — Rashida Johnson

(74) *Attorney, Agent, or Firm* — Donald J. Ranft; Collen IP

(57) **CLAIM**

The ornamental design for a reed for musical instruments, as shown.

DESCRIPTION

FIG. 1 is a top perspective view of a reed for musical instruments showing our new design;
FIG. 2 is a bottom perspective view thereof;
FIG. 3 is a top plan view thereof;
FIG. 4 is a bottom plan view thereof;
FIG. 5 is a left side view thereof; the right side being a mirror image;
FIG. 6 is a front elevational view thereof; and,
FIG. 7 is a back elevational view thereof.

1 Claim, 2 Drawing Sheets

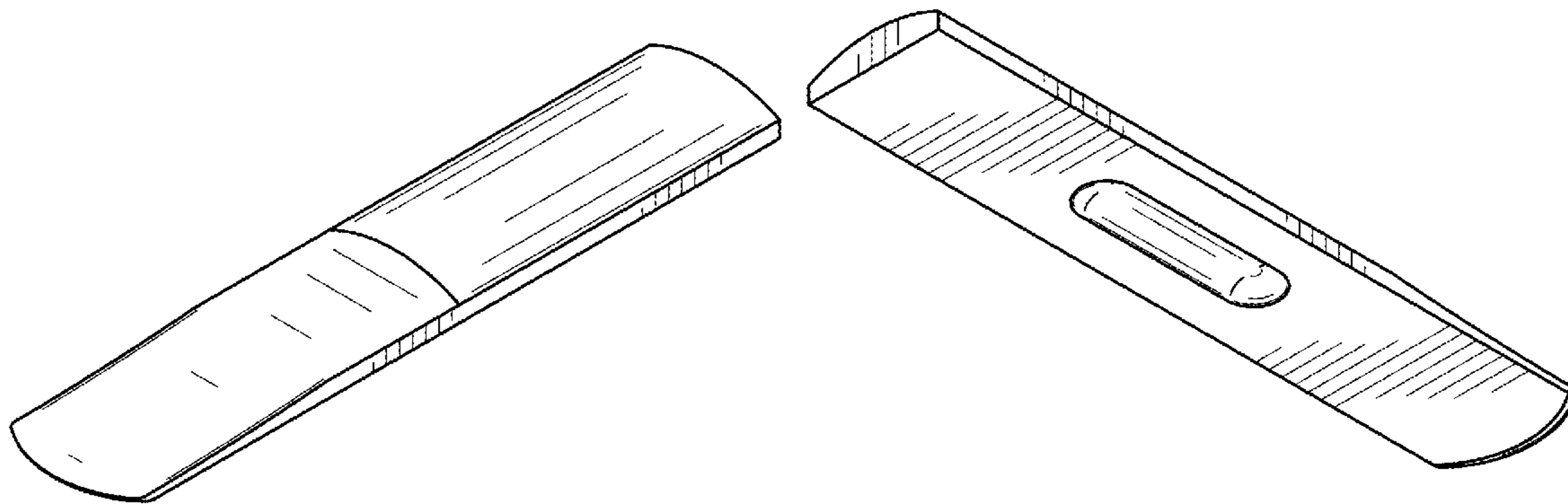

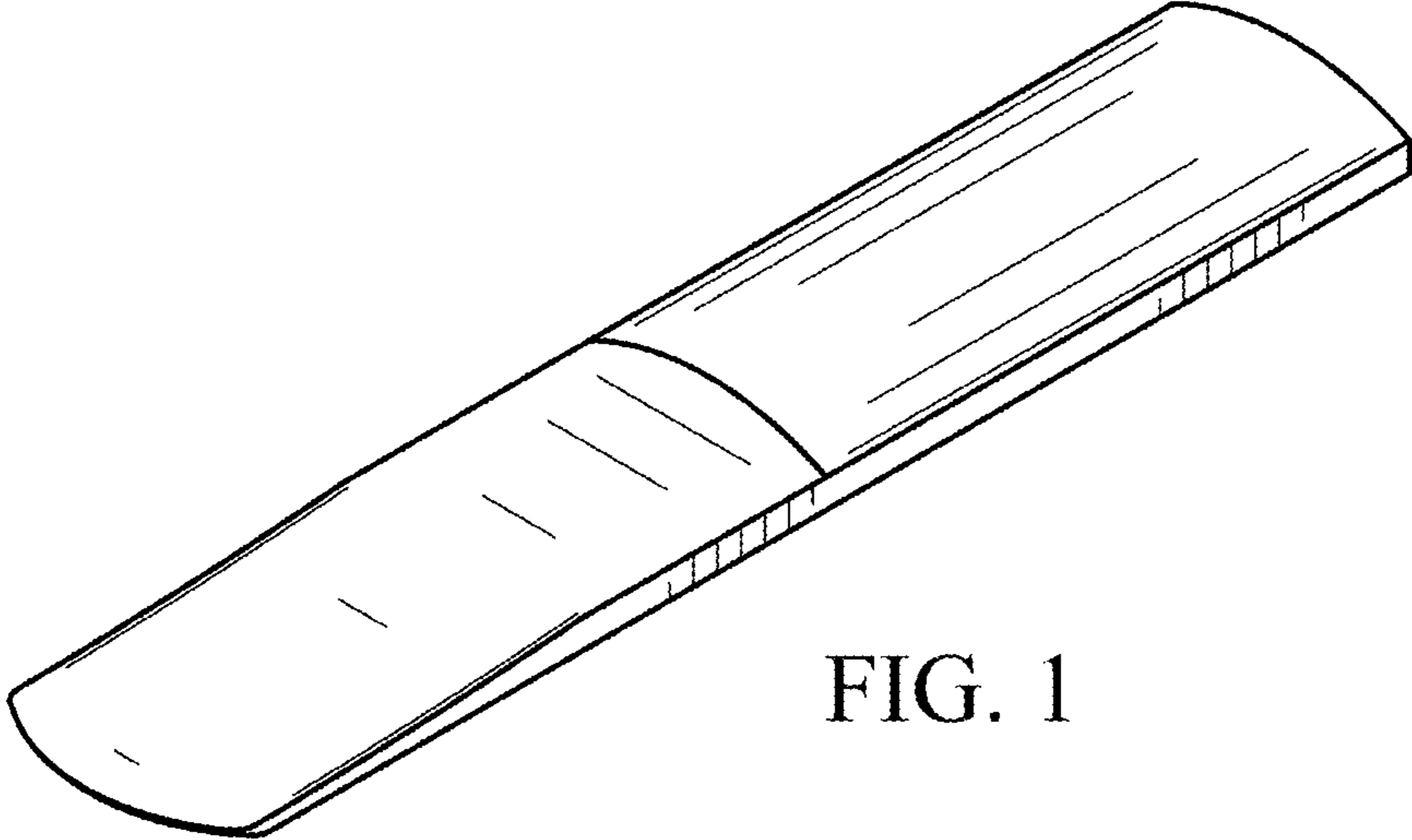

FIG. 1

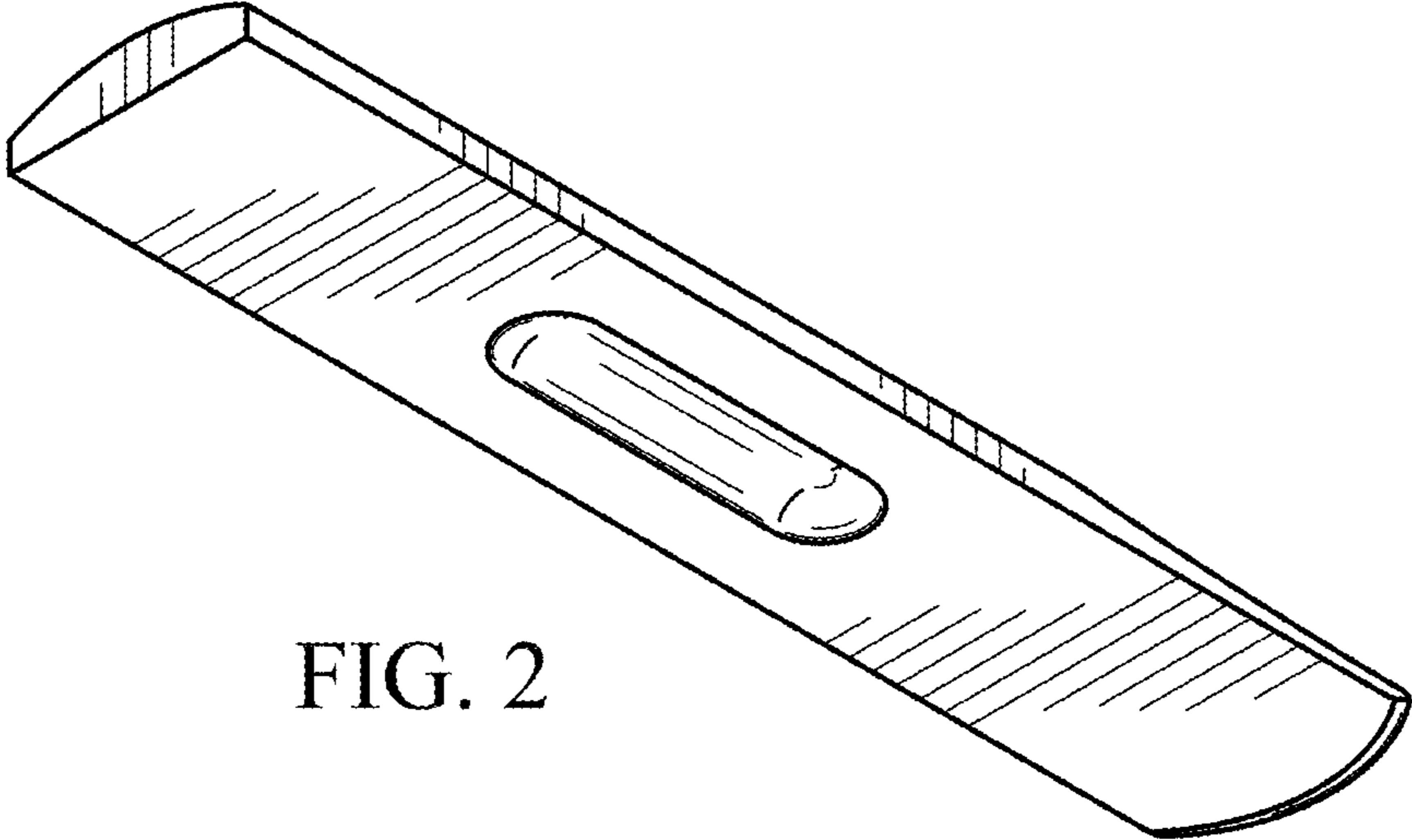

FIG. 2

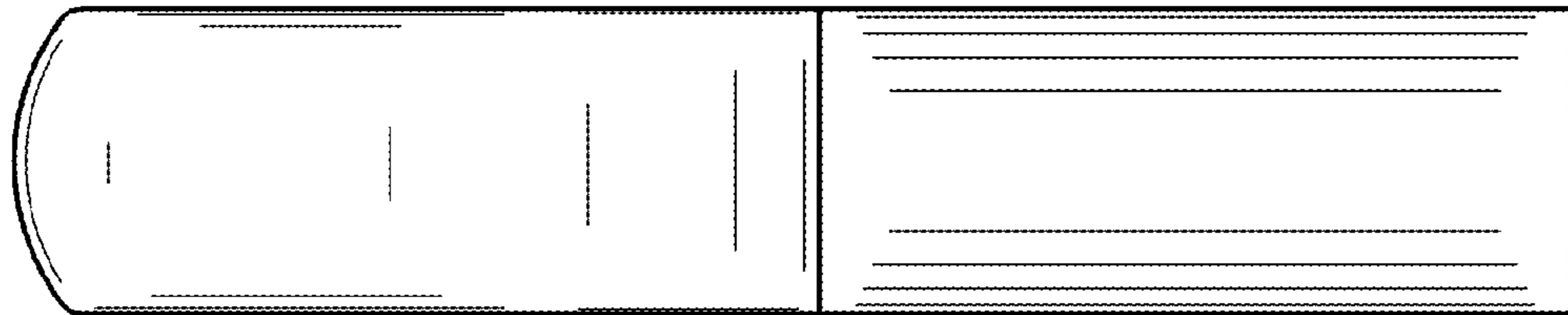

FIG. 3

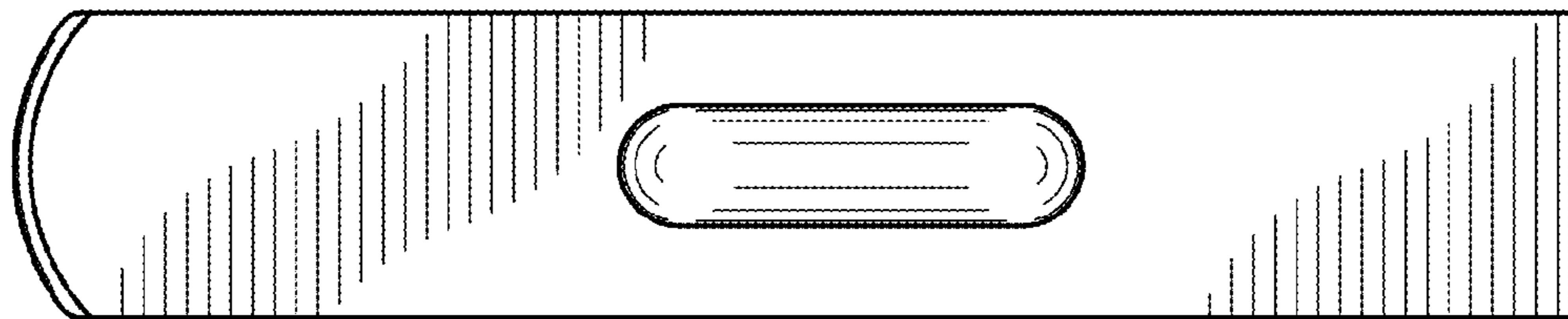

FIG. 4



FIG. 5

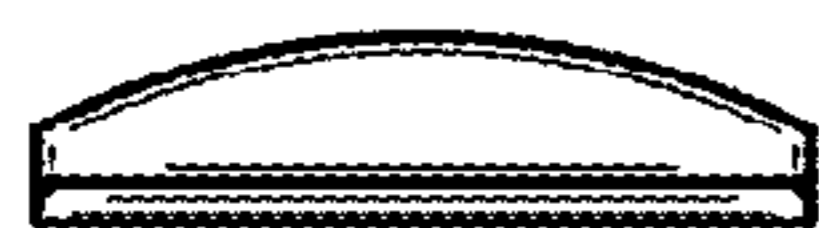

FIG. 6



FIG. 7