



US00D710905S

(12) **United States Design Patent**
Park et al.

(10) **Patent No.:** **US D710,905 S**

(45) **Date of Patent:** **** Aug. 12, 2014**

(54) **COMPRESSOR FOR VEHICLES**

(71) Applicant: **Halla Visteon Climate Control Corp.**,
Daejeon (KR)

(72) Inventors: **Bok Ki Park**, Daejeon (KR); **Eun Gi Son**,
Daejeon (KR); **Seung Taek Lim**, Daejeon (KR)

(73) Assignee: **Halla Visteon Climate Control Corp.**,
Daejeon (KR)

(**) Term: **14 Years**

(21) Appl. No.: **29/483,371**

(22) Filed: **Feb. 27, 2014**

(30) **Foreign Application Priority Data**

Jan. 28, 2014 (KR) 30-2014-0004700

(51) **LOC (10) Cl.** **15-02**

(52) **U.S. Cl.**
USPC **D15/9**

(58) **Field of Classification Search**
CPC F01B 3/00; F01B 13/04; F01B 1/26;
F04B 1/12; F04B 39/124
USPC D15/7-9; D23/231, 232, 225; 417/60,
417/235, 265, 321, 355, 358, 363, 359,
417/410.1, 415-416, 405, 900, 231, 313,
417/273, 539; 60/408, 412; 184/26-37;
415/140-147; 123/495, 509; 418/259
See application file for complete search history.

(56) **References Cited**

U.S. PATENT DOCUMENTS

D351,603 S * 10/1994 Ikeda et al. D15/9
5,470,207 A * 11/1995 Shockey et al. 417/313

D381,340 S * 7/1997 Takenaka et al. D15/9
D381,993 S * 8/1997 Takenaka et al. D15/9
5,674,054 A * 10/1997 Ota et al. 417/269
D429,738 S * 8/2000 Kayukawa et al. D15/9
D432,139 S * 10/2000 Chisenhall D15/9
D440,232 S * 4/2001 Kou D15/9
D441,377 S * 5/2001 Kawaguchi et al. D15/9
D441,378 S * 5/2001 Kou D15/9
D456,029 S * 4/2002 Kawaguchi et al. D15/9
D456,423 S * 4/2002 Kanou et al. D15/9
D460,460 S * 7/2002 Kayukawa et al. D15/9
6,532,859 B1 * 3/2003 Kuhn et al. 92/71
D479,534 S * 9/2003 Shiina D15/9
D573,159 S * 7/2008 Etter D15/7
D695,789 S * 12/2013 Nam D15/9

* cited by examiner

Primary Examiner — Ralf Seifert

(74) *Attorney, Agent, or Firm* — Dickinson Wright PLLC

(57) **CLAIM**

We claim the ornamental design for a compressor for vehicles, as shown herein.

DESCRIPTION

FIG. 1 is a perspective view of a compressor according to the present design;
FIG. 2 is a front view of the compressor according to the present design;
FIG. 3 is a rear view of the compressor according to the present design;
FIG. 4 is a left side view of the compressor according to the present design;
FIG. 5 is a right side view of the compressor according to the present design;
FIG. 6 is a plan view of the compressor according to the present design; and,
FIG. 7 is a bottom view of the compressor according to the present design.

1 Claim, 7 Drawing Sheets

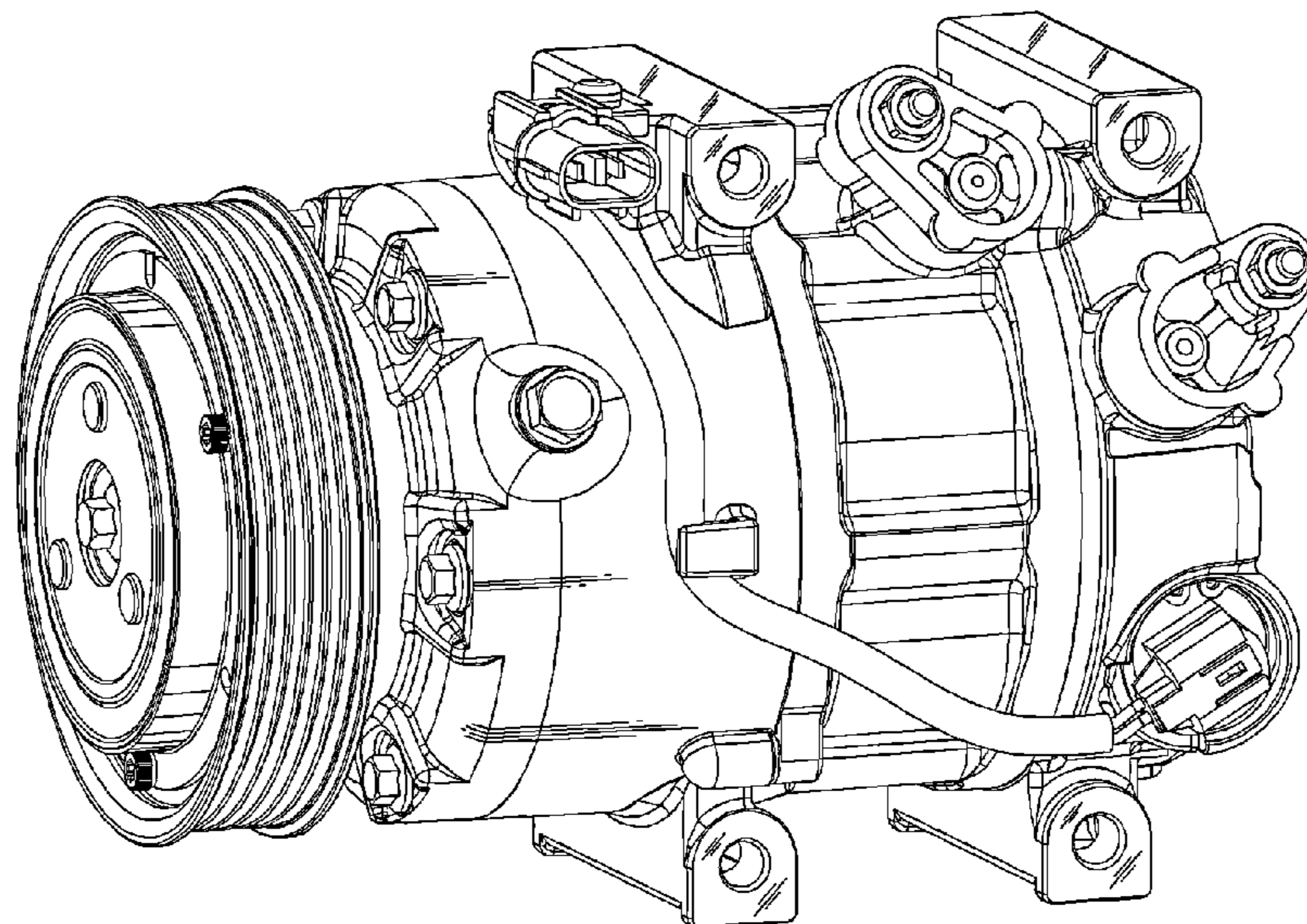

Fig. 1

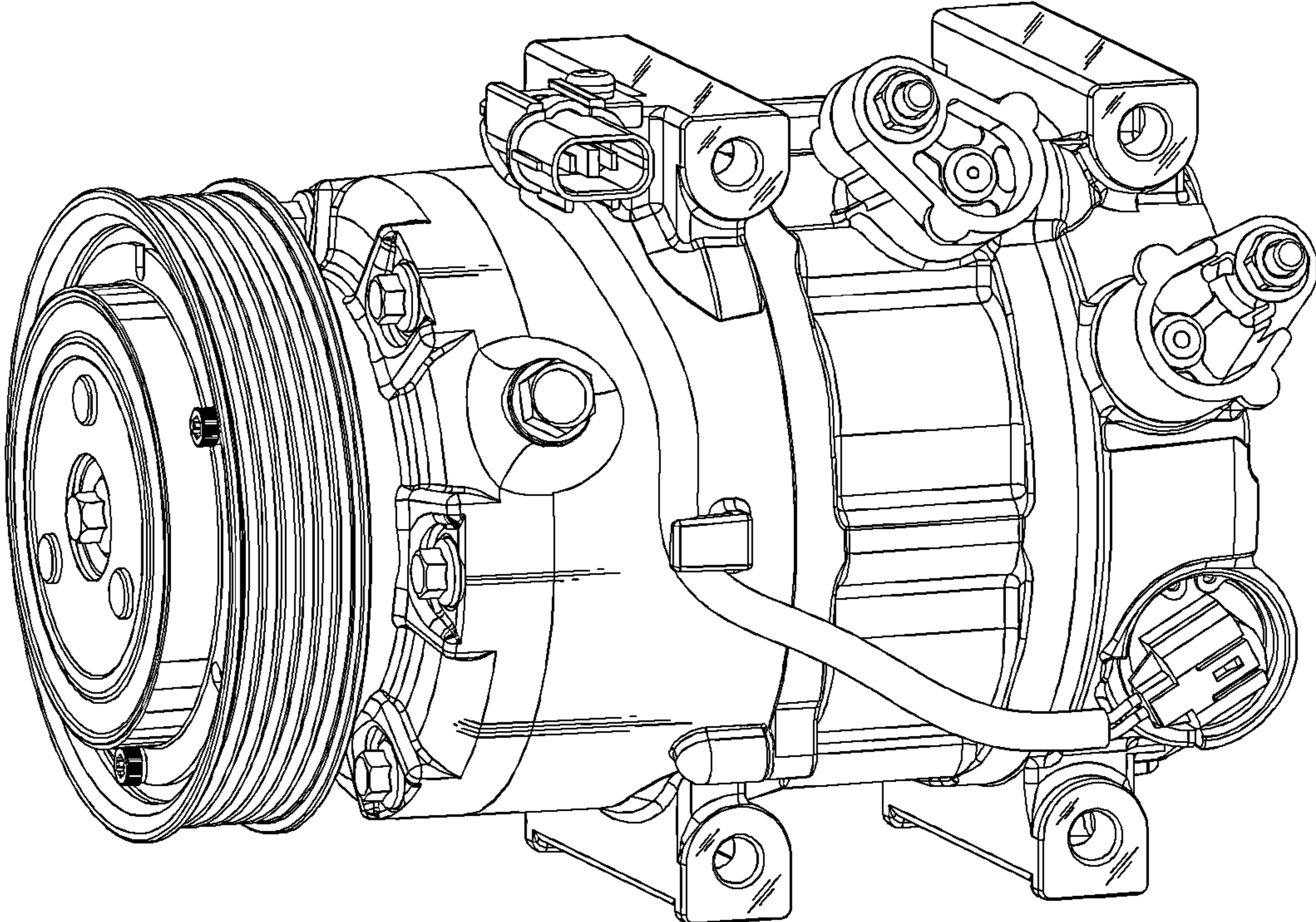

Fig. 2

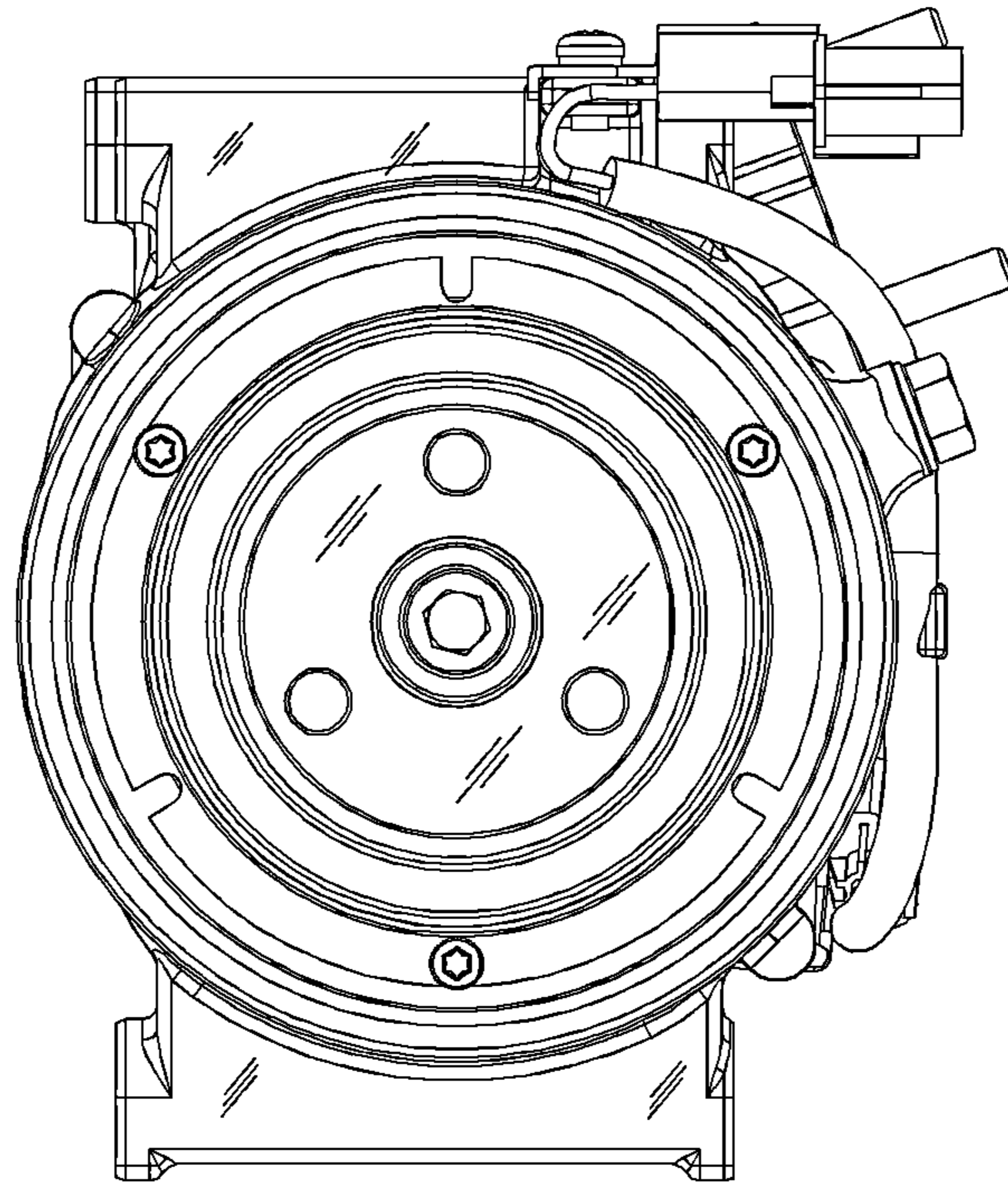

Fig. 3

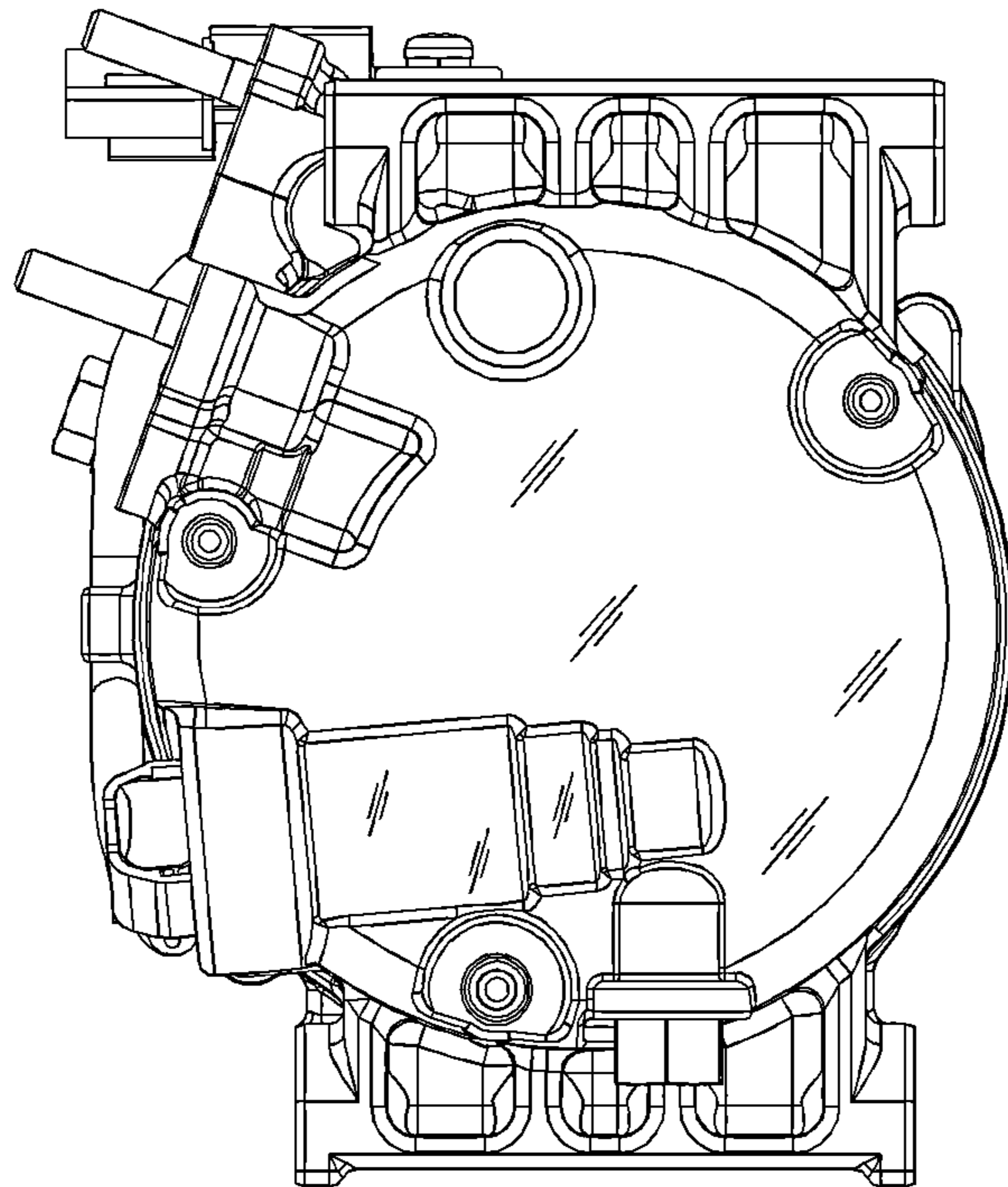

Fig. 4

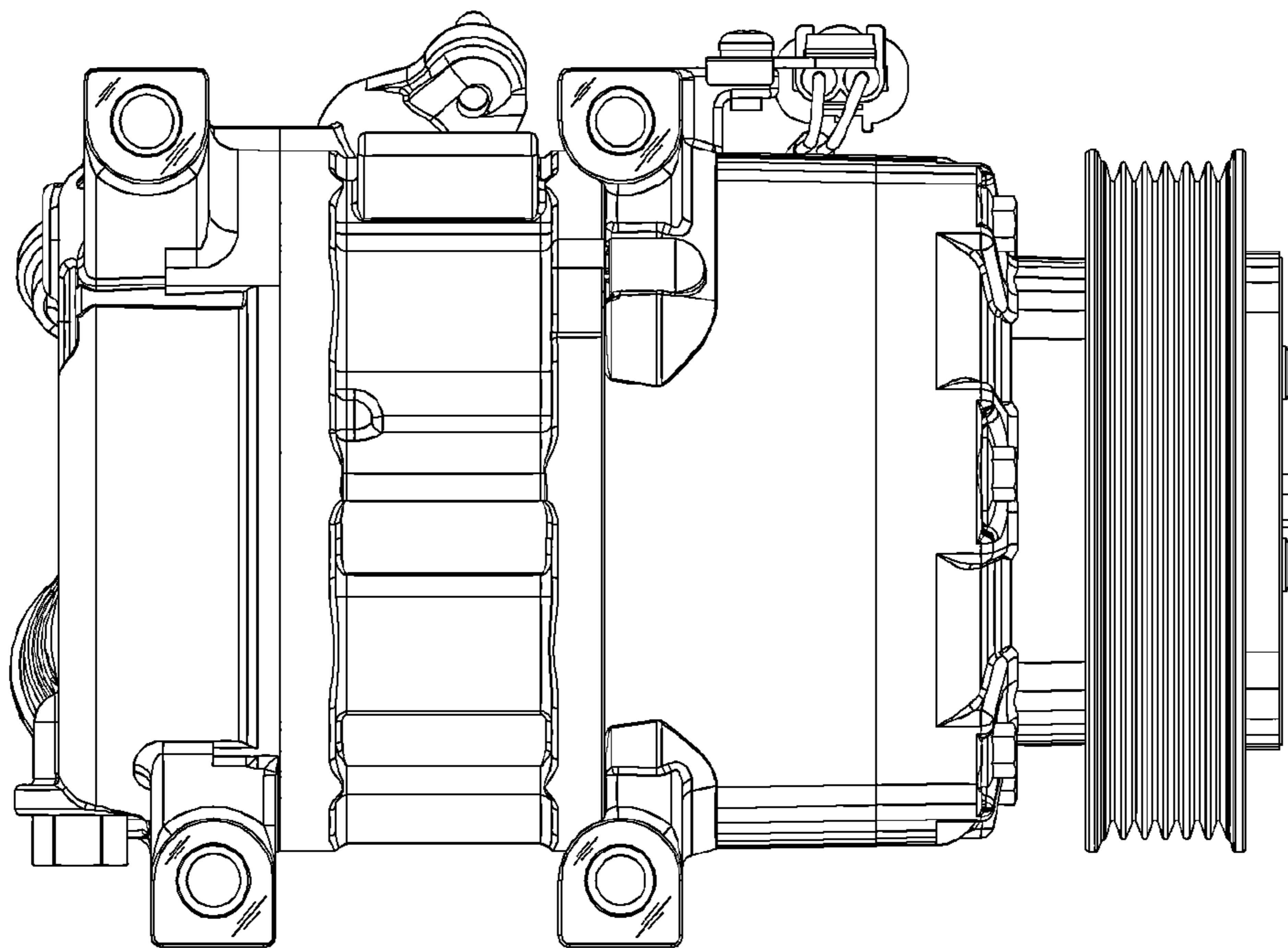

Fig. 5

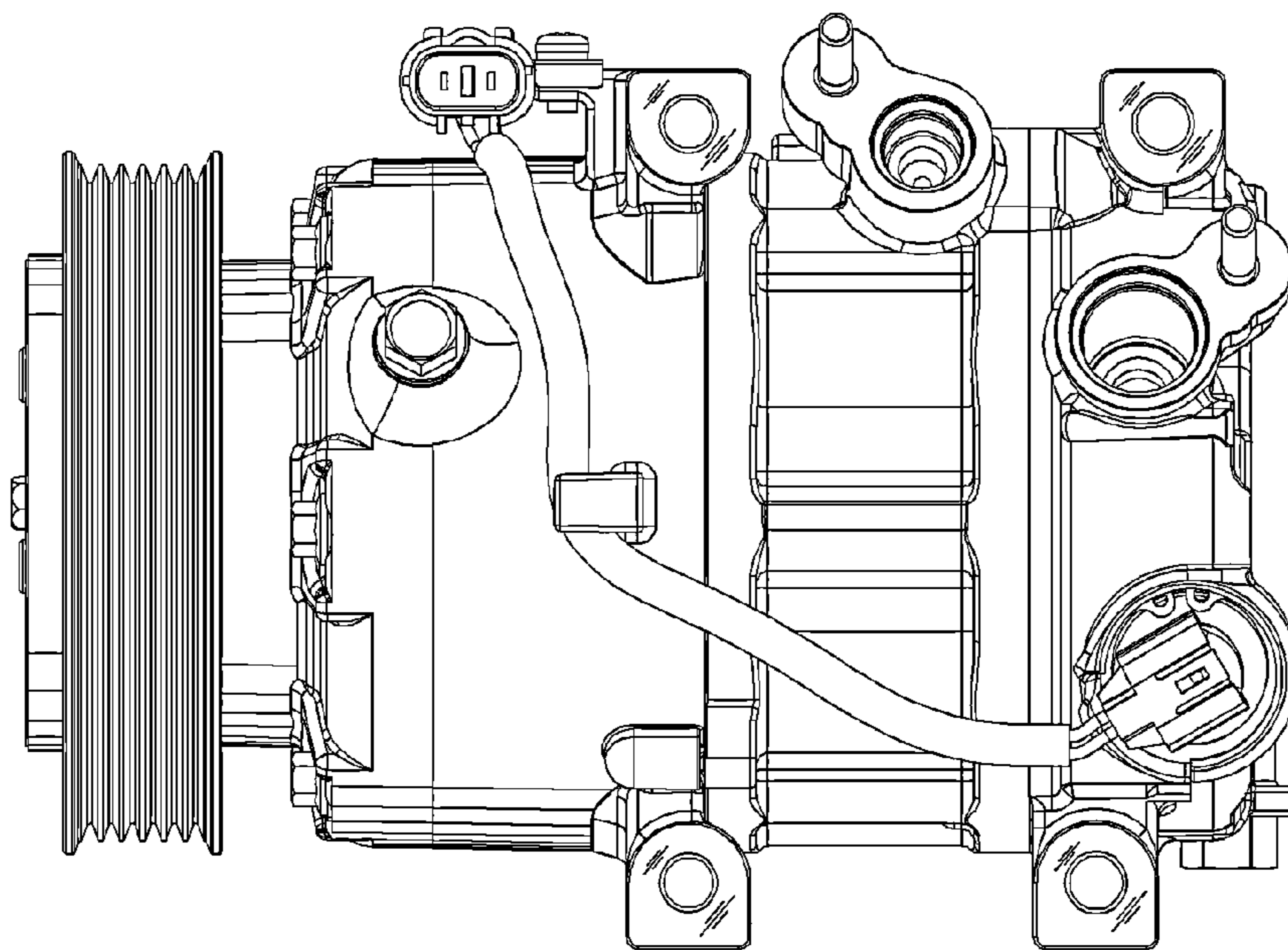

Fig. 6

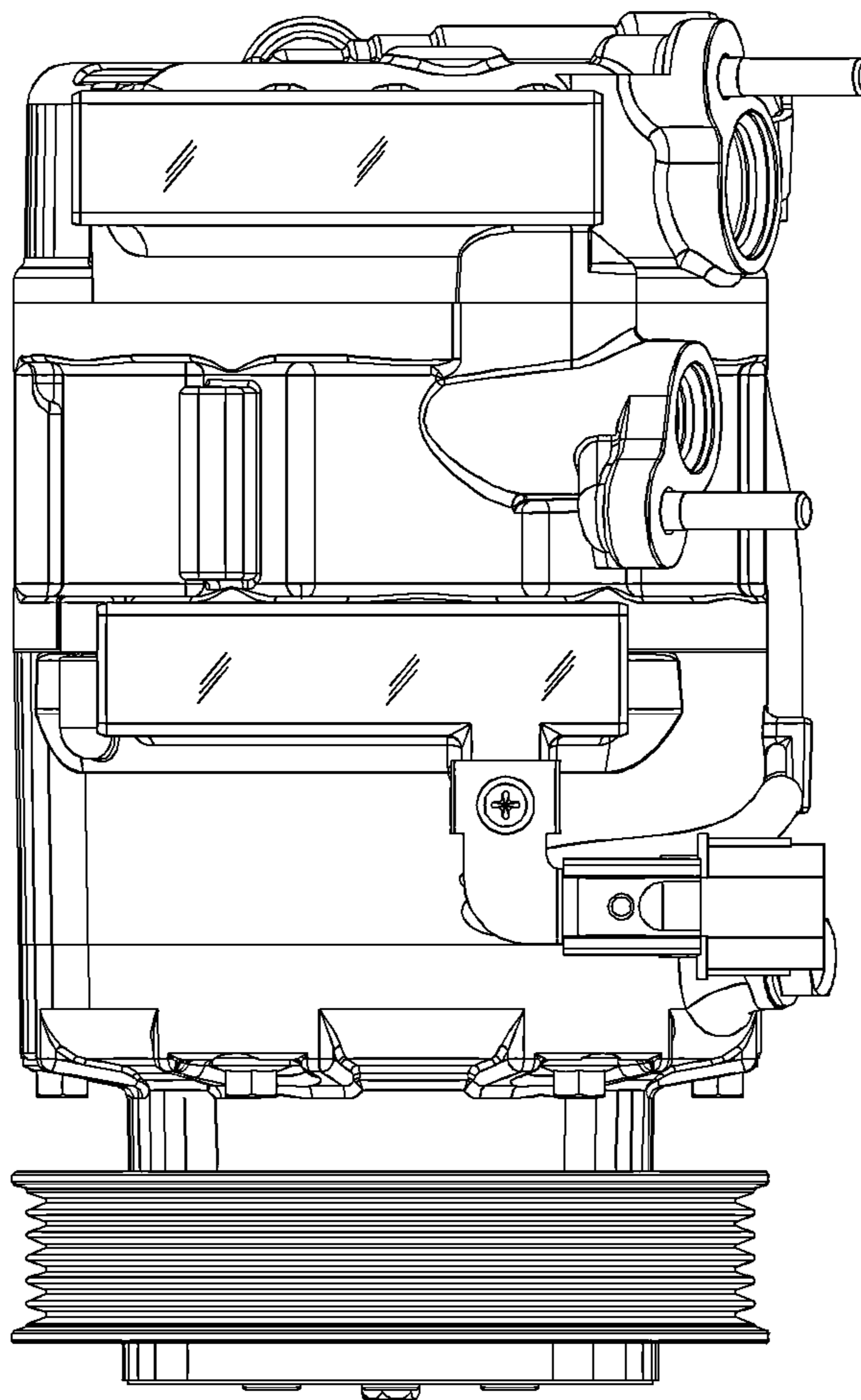

Fig. 7

