



US00D710899S

(12) **United States Design Patent**  
**Kuehner et al.**

(10) **Patent No.:** **US D710,899 S**  
(45) **Date of Patent:** **\*\* Aug. 12, 2014**

(54) **ENGINE**

(56) **References Cited**

(71) Applicant: **Cummins Inc.**, Columbus, IN (US)

U.S. PATENT DOCUMENTS

(72) Inventors: **Jessica A. Kuehner**, Columbus, IN (US); **Bradley M. Luedeke**, Columbus, IN (US); **Michael P. McCombs**, Columbus, IN (US); **Taylor Thomas**, Indianapolis, IN (US); **Gregory J. Mitchum**, Franklin, IN (US); **Robert E. Hoye, III**, Columbus, IN (US); **Logan A. Harvey**, Hope, IN (US); **Matthew Whitaker**, Columbus, IN (US); **Dustin A. Wolf**, Columbus, IN (US)

6,601,528	B2 *	8/2003	Bilek et al. ....	114/55.5
D494,191	S *	8/2004	Aketa et al. ....	D15/1
D610,164	S *	2/2010	Takahata et al. ....	D15/1
D665,425	S *	8/2012	Genter et al. ....	D15/3
D685,819	S *	7/2013	Hataura et al. ....	D15/1
D685,820	S *	7/2013	Okuda et al. ....	D15/3
2001/0039908	A1 *	11/2001	Bilek et al. ....	114/55.5
2004/0231623	A1 *	11/2004	El Tahry et al. ....	123/90.15

\* cited by examiner

*Primary Examiner* — T. Chase Nelson

*Assistant Examiner* — Ania Aman

(74) *Attorney, Agent, or Firm* — Faegre Baker Daniels LLP

(73) Assignee: **Cummins Inc.**, Columbus, IN (US)

(57) **CLAIM**

The ornamental design for an engine, as shown and described.

(\*\*) Term: **14 Years**

**DESCRIPTION**

(21) Appl. No.: **29/452,097**

(22) Filed: **Apr. 11, 2013**

(51) **LOC (10) Cl.** ..... **15-01**

(52) **U.S. Cl.**  
USPC ..... **D15/1**

(58) **Field of Classification Search**  
USPC ..... D15/1, 2, 3, 5, 6, 14, 17, 149; 123/22, 123/41.34, 51 A, 606 R, 52.1, 50 A, 50 B, 123/54.1, 54.2, 54.4, 54.5, 65 R, 195 R, 123/195 HC, 657, 311

FIG. 1 is a left side frontal perspective view of the engine; FIG. 2 is a right side frontal perspective view of the engine; FIG. 3 is a left side rear perspective view of the engine; FIG. 4 is a right side rear perspective view of the engine; FIG. 5 is a front view of the engine; FIG. 6 is a rear view of the engine; FIG. 7 is a top view of the engine; FIG. 8 is a bottom view of the engine; FIG. 9 is a left side view of the engine; and, FIG. 10 is a right side view of the engine. It should be appreciated that the broken lines of FIG. 5 illustrate portions of the engine that form no part of the claimed design.

See application file for complete search history.

**1 Claim, 10 Drawing Sheets**

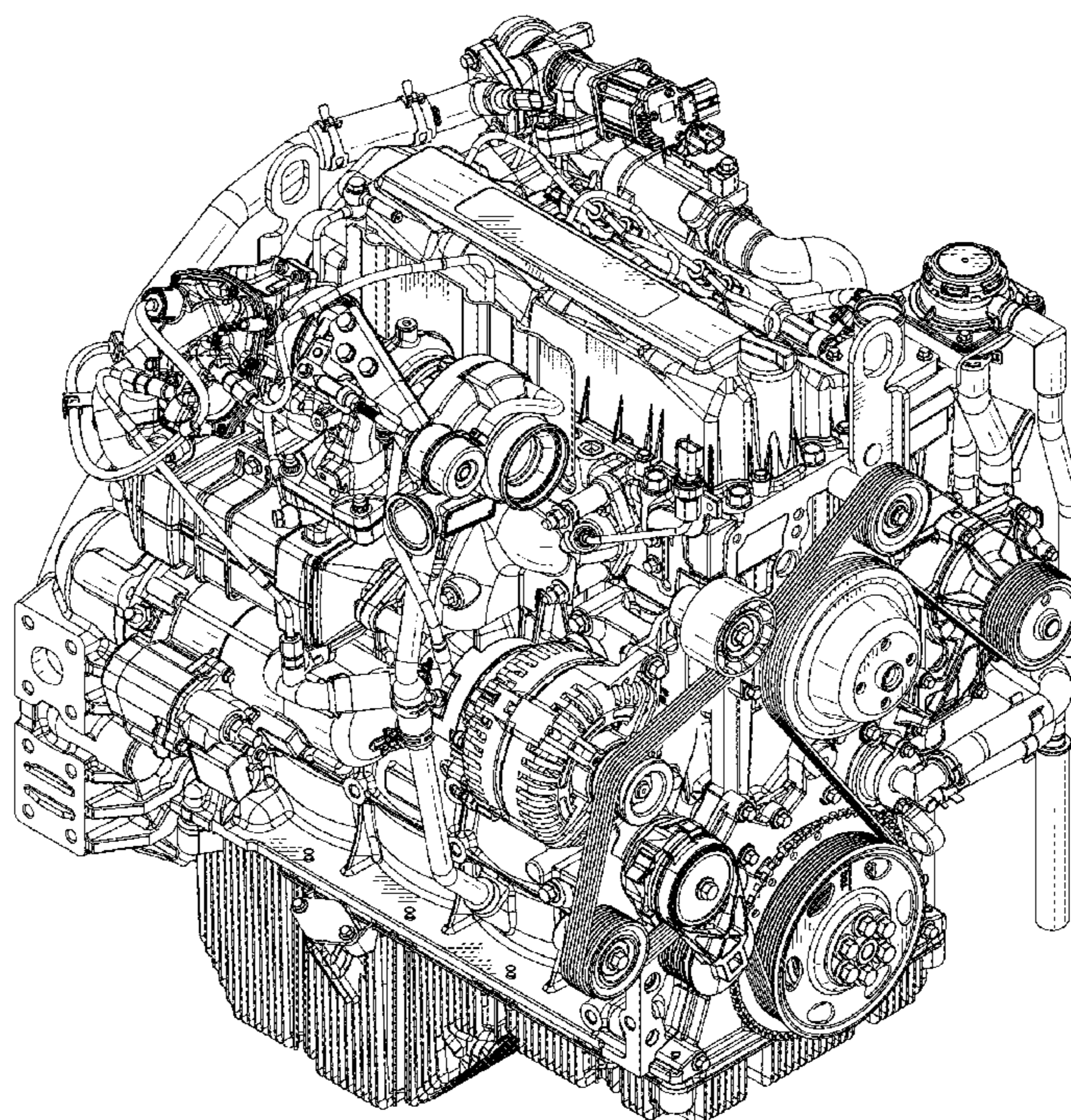



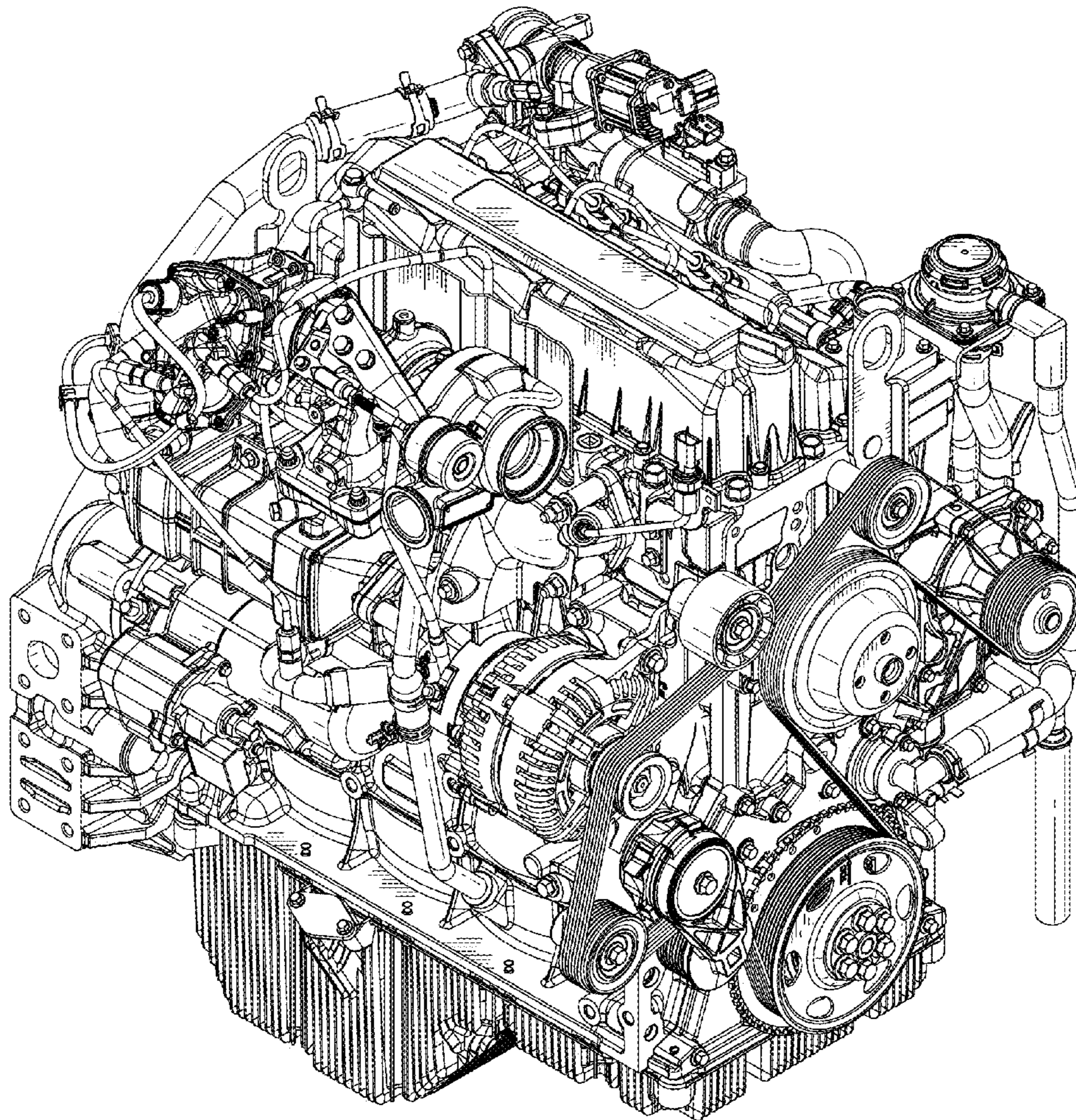

FIG. 1



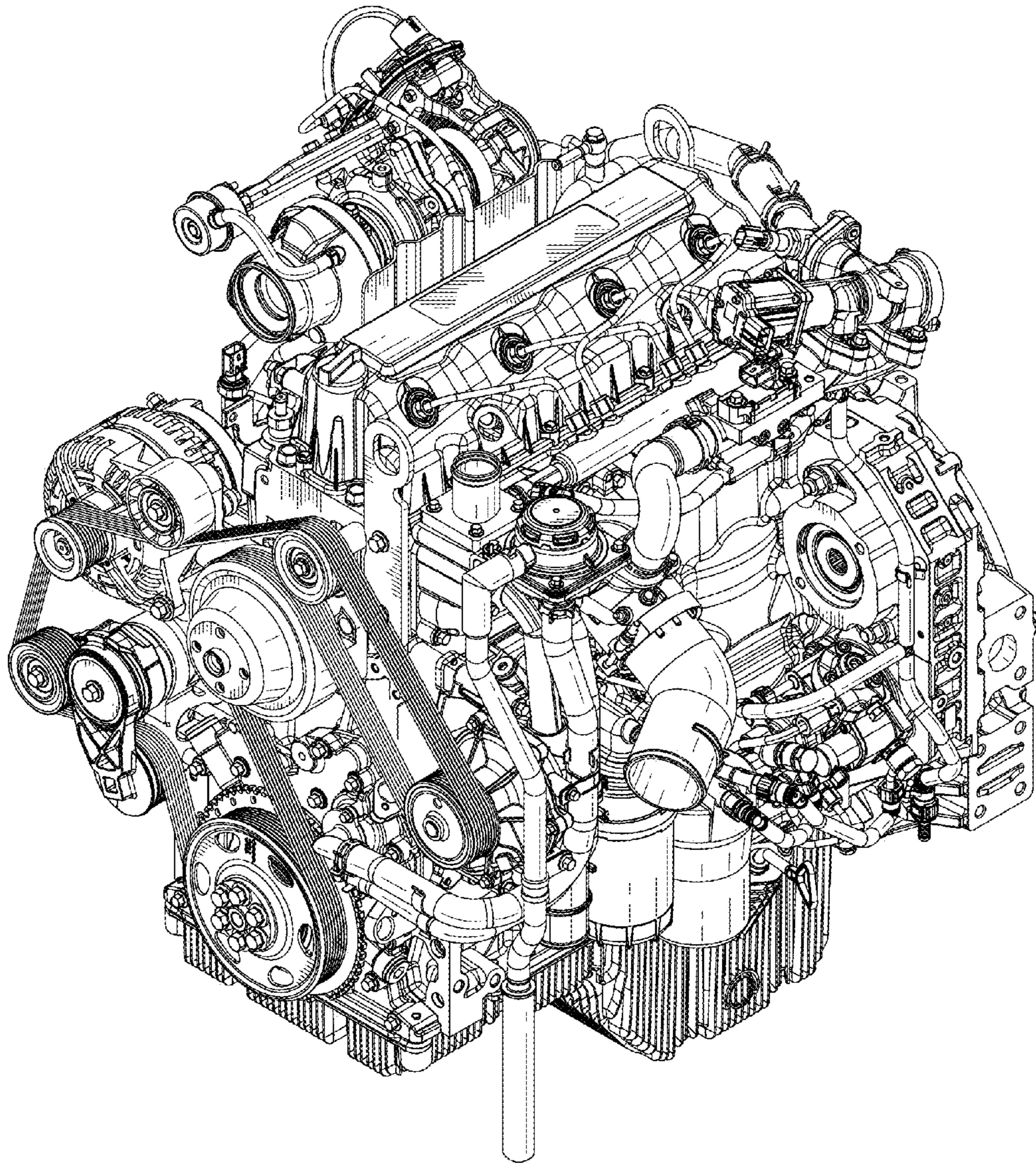

FIG. 2



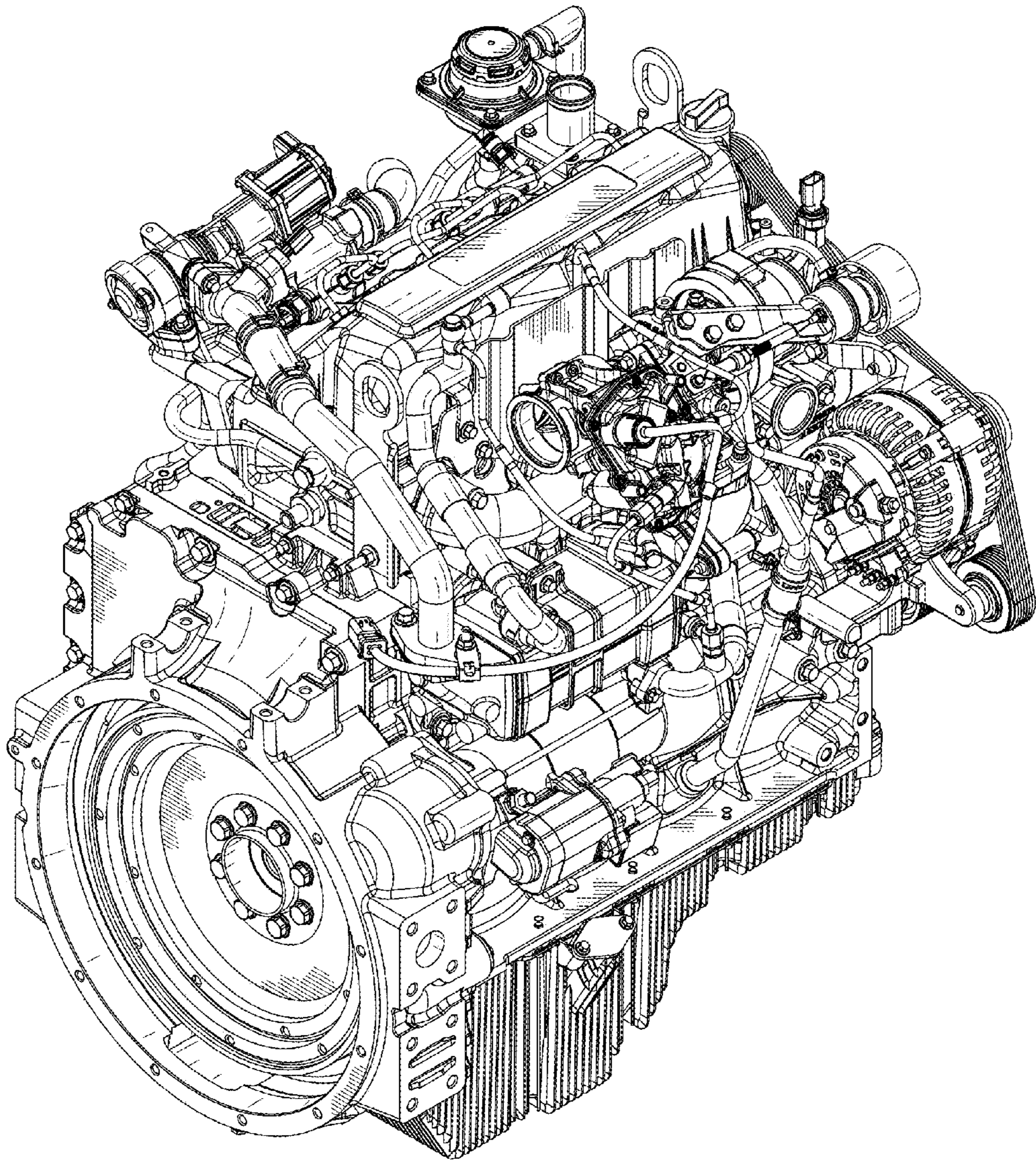

FIG. 3



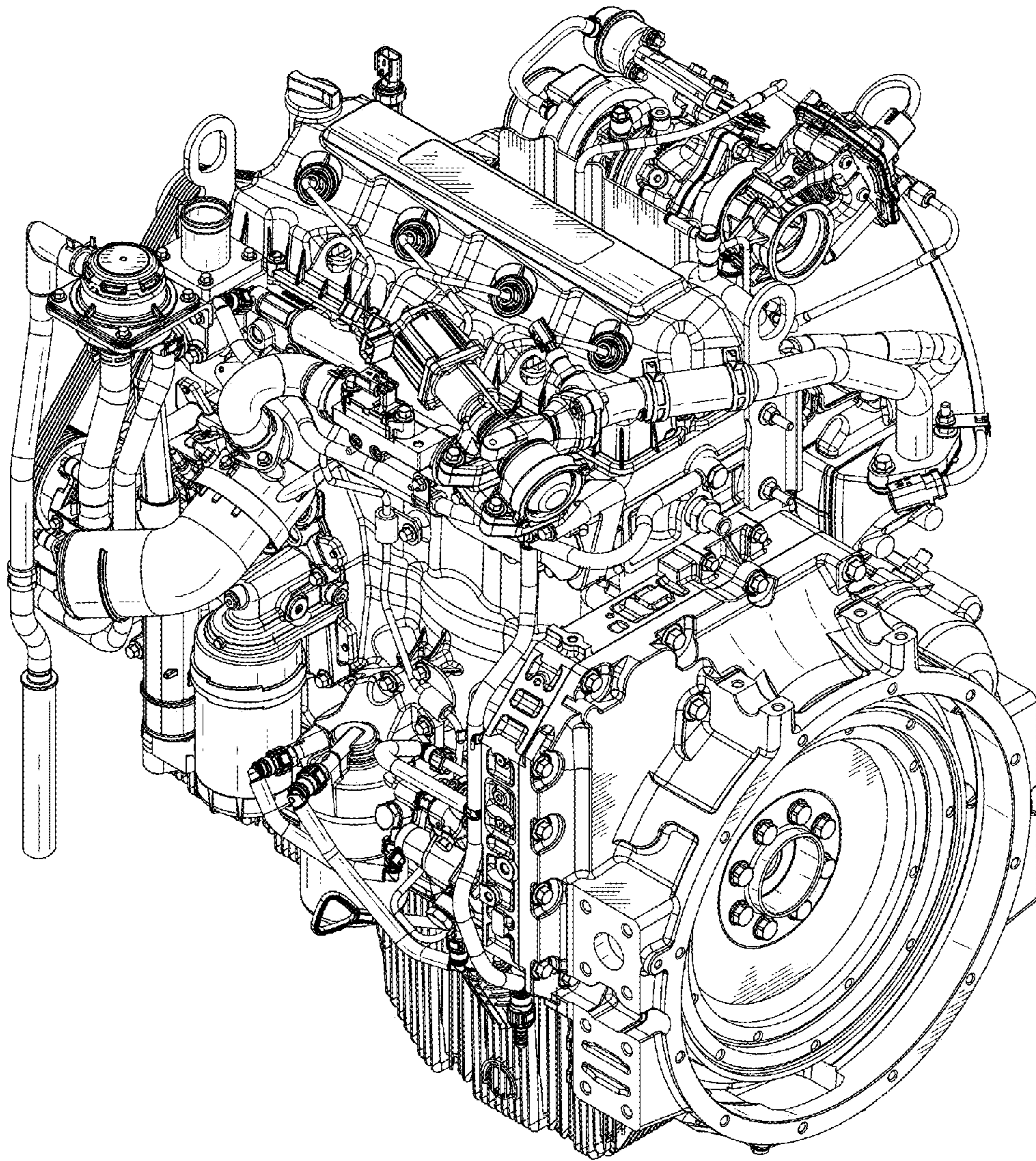

FIG. 4



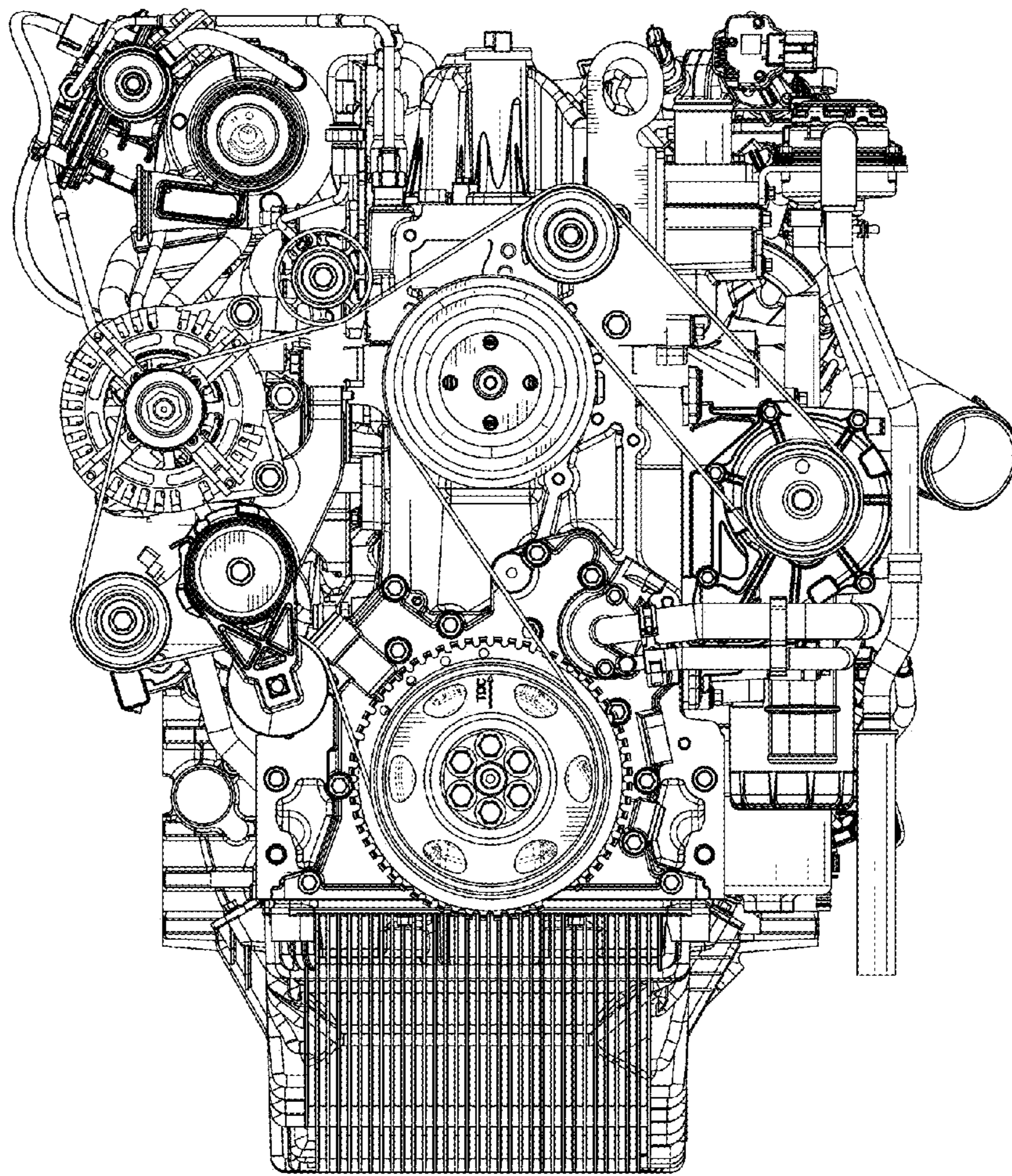

FIG. 5

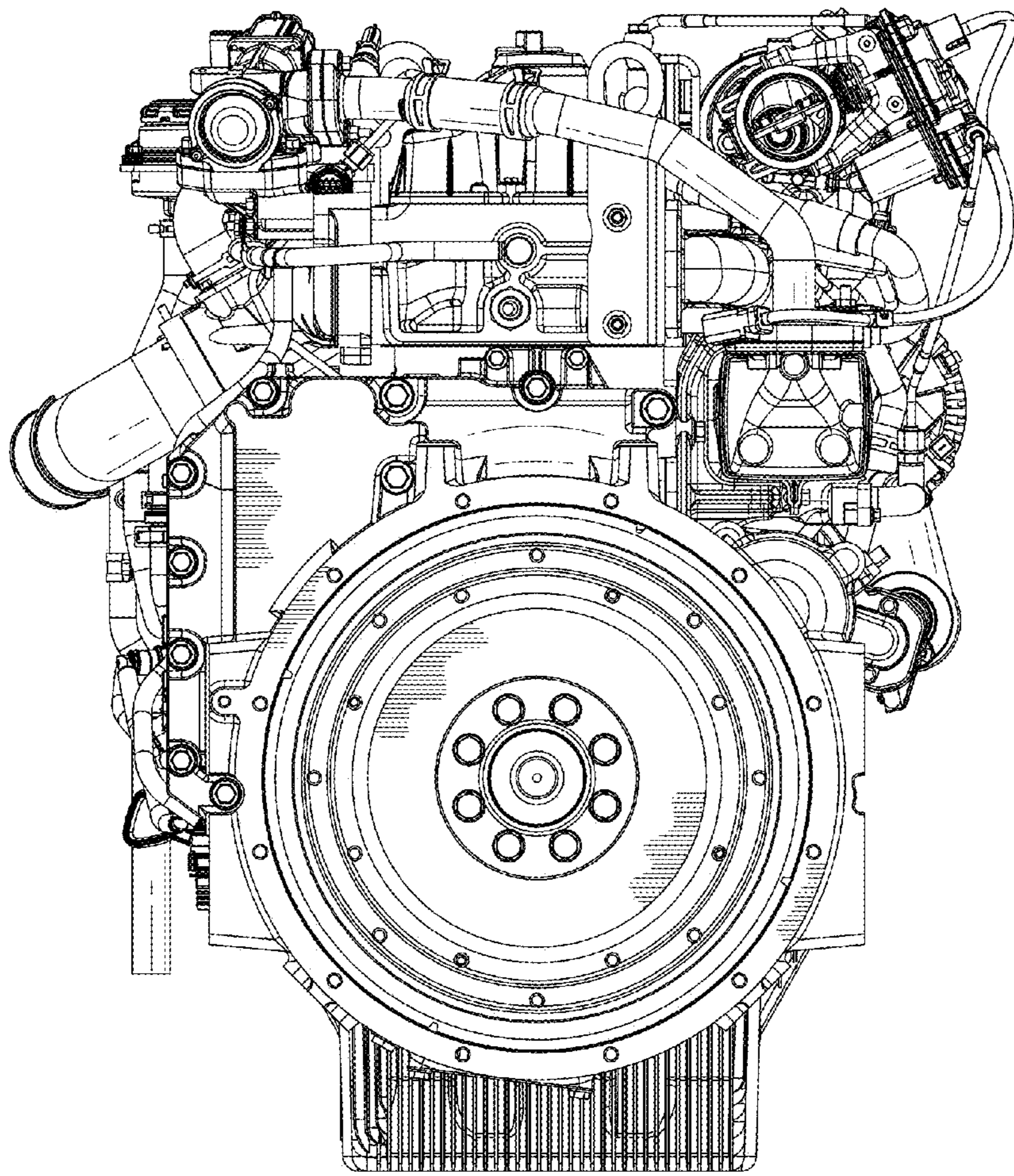

FIG. 6



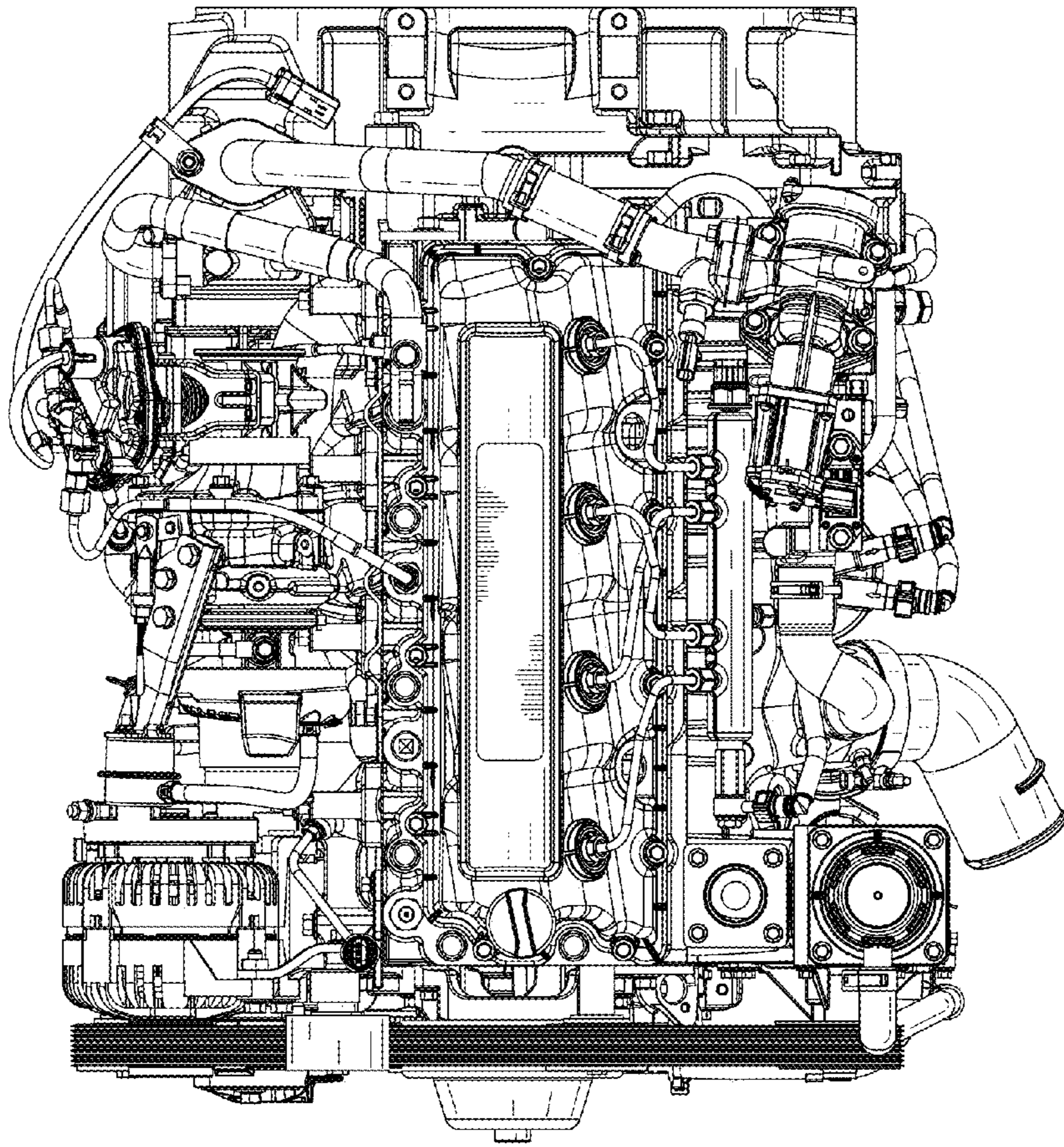

FIG. 7



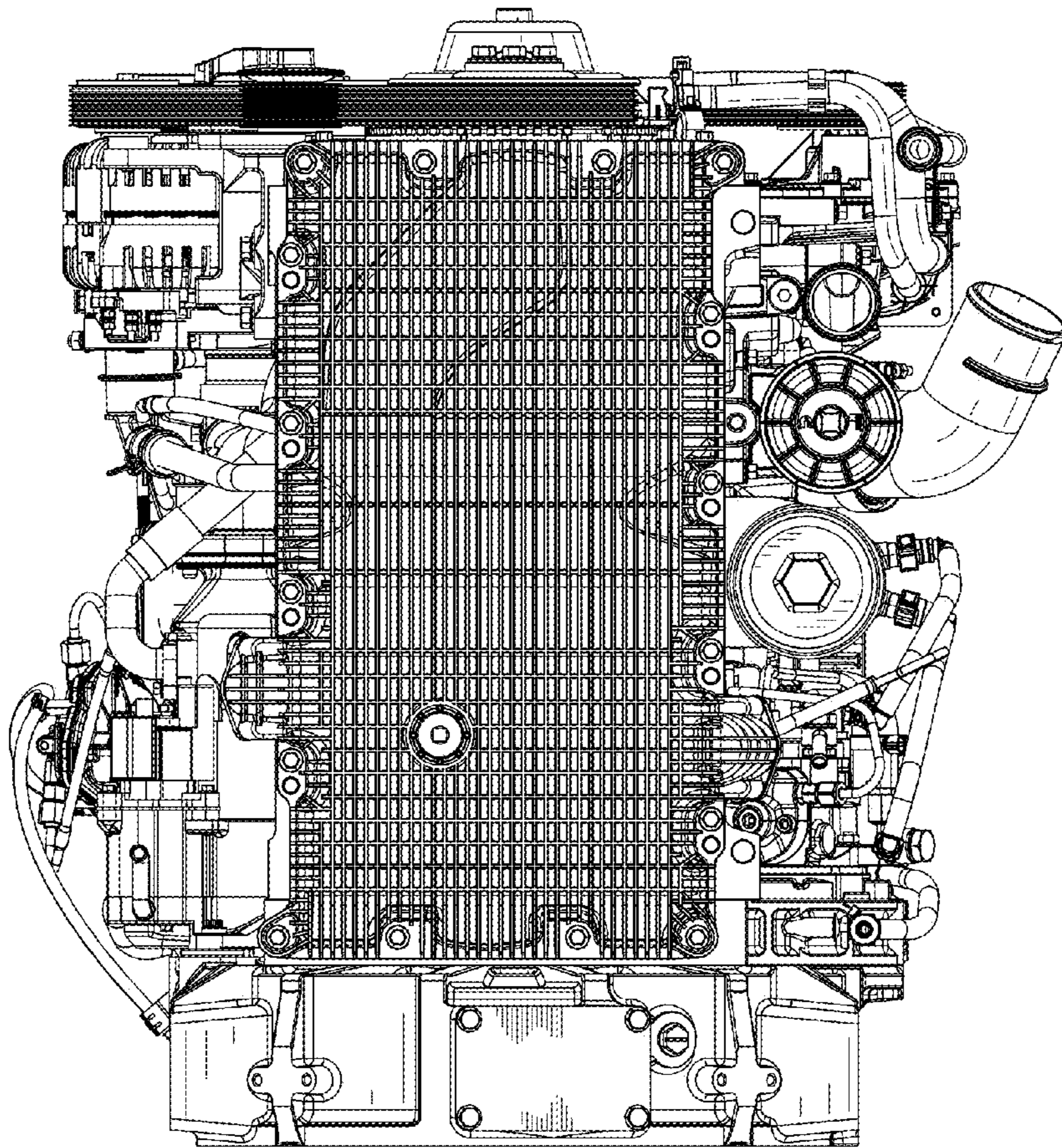

FIG. 8



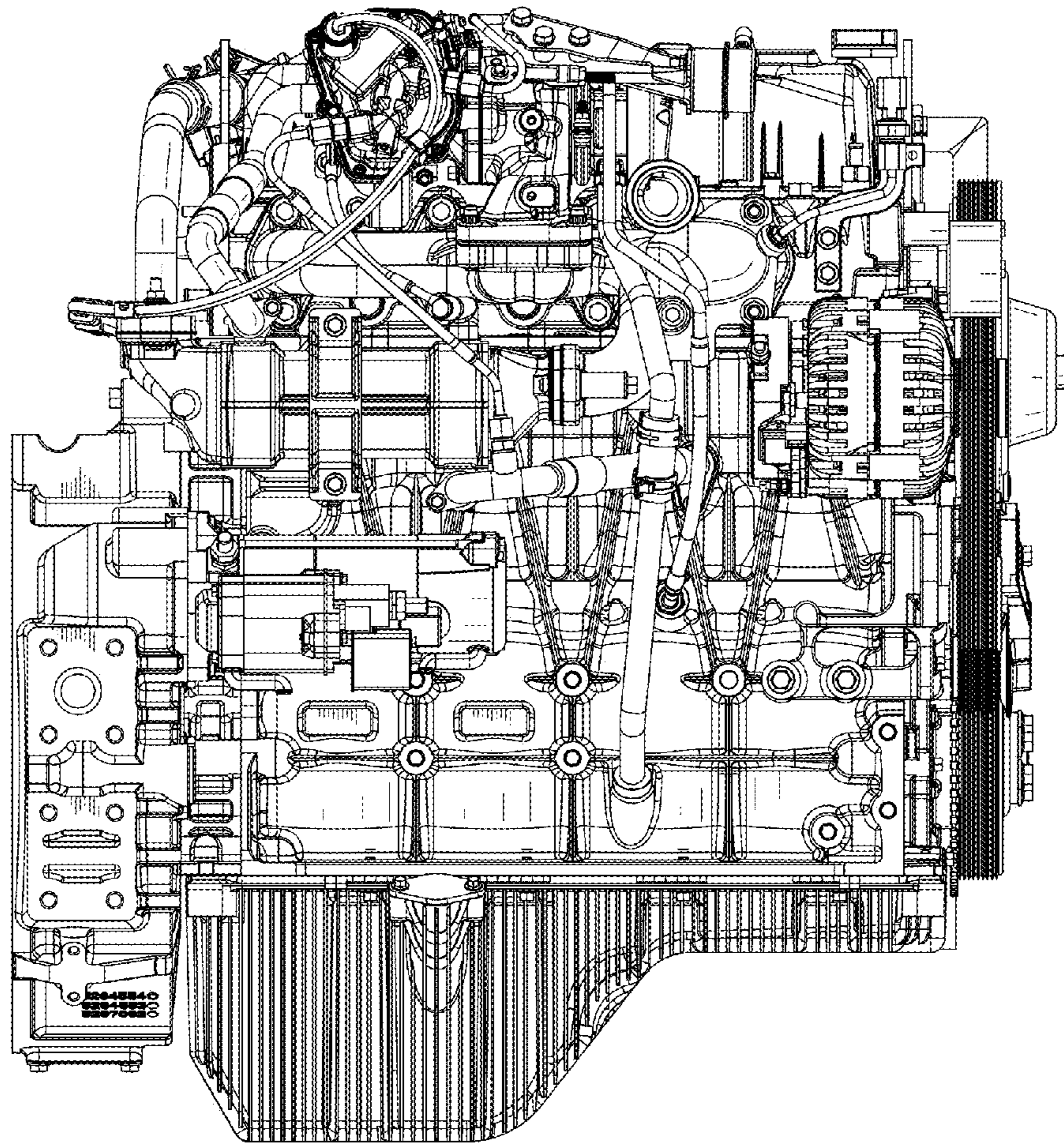

FIG. 9



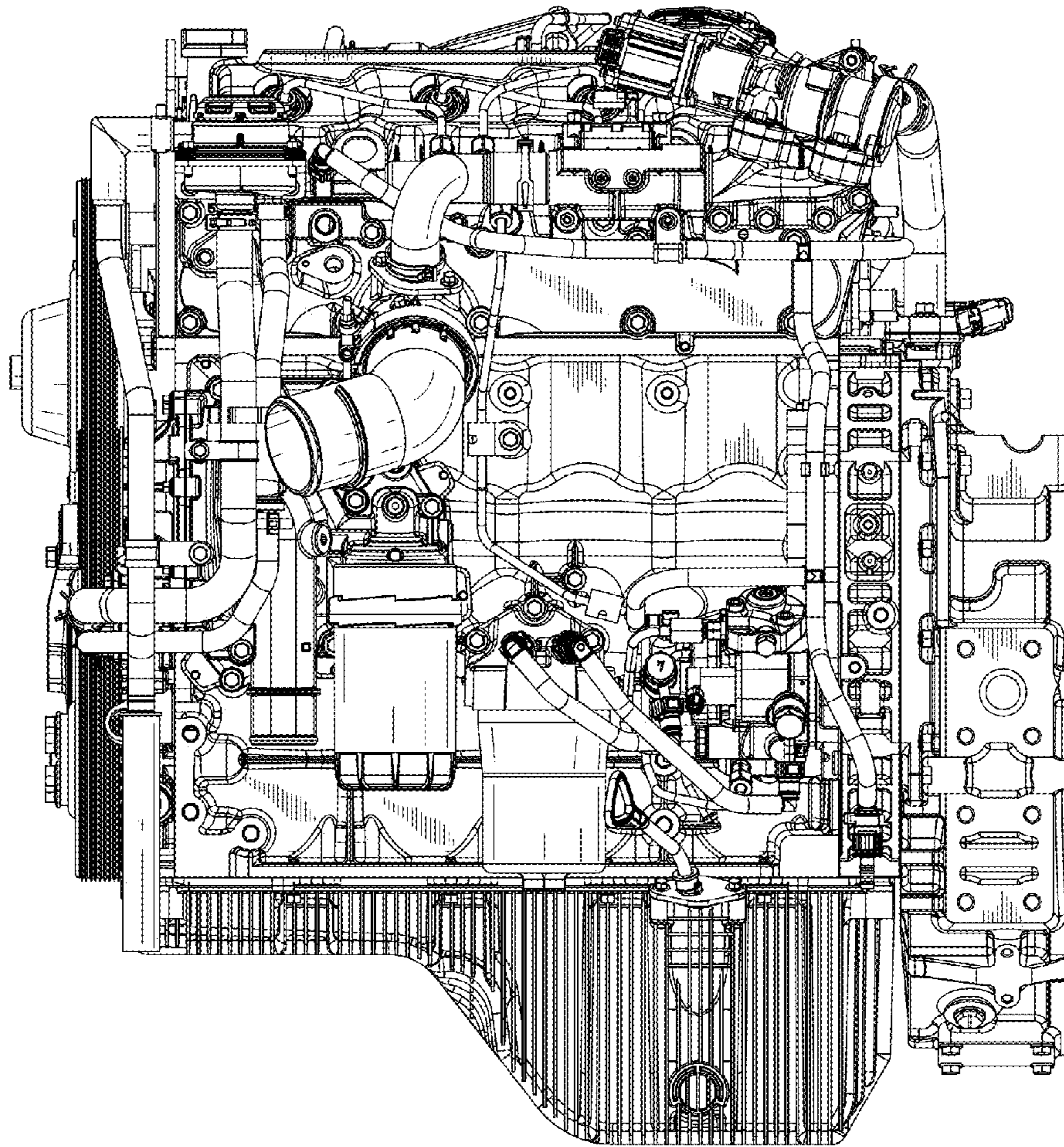

FIG. 10