



US00D710782S

(12) **United States Design Patent**  
**Cummings**

(10) **Patent No.:** **US D710,782 S**

(45) **Date of Patent:** **\*\* Aug. 12, 2014**

(54) **AIR VEHICLE HAVING ROTATABLE AND RETRACTABLE PAIRS OF WINGS**

(71) Applicant: **Darold B. Cummings**, Coeur D'Alene, ID (US)

(72) Inventor: **Darold B. Cummings**, Coeur D'Alene, ID (US)

(\*\*) Term: **14 Years**

(21) Appl. No.: **29/466,169**

(22) Filed: **Sep. 5, 2013**

(51) **LOC (10) Cl.** ..... **12-07**

(52) **U.S. Cl.**  
USPC ..... **D12/326; D12/328**

(58) **Field of Classification Search**

CPC ..... B64C 2201/024; B64C 2201/102; B64C 3/38; B64C 3/385; B64C 3/56; B64C 27/00; B64C 27/08; B64C 27/10; B64C 27/22; B64C 39/08; Y02T 50/145  
USPC ..... D12/319, 320, 326, 327, 328, 329, 330, D12/333, 338, 339, 344, 345; D21/430, D21/436, 437, 441, 442, 443, 444, 447, 450, D21/451, 453; 244/2, 5, 6, 7 A, 7 R, 7 C, 244/3.28, 12.5, 46, 49, 218; 446/34-38, 446/57-60, 230-236; 280/1.12, 1.21

See application file for complete search history.

(56) **References Cited**

**U.S. PATENT DOCUMENTS**

D190,840	S	*	7/1961	Lear, Sr.	.....	D12/339
3,116,036	A	*	12/1963	Nichols	.....	244/7 A
3,206,146	A	*	9/1965	Toms	.....	244/46
D218,856	S	*	9/1970	Fellers	.....	D12/338
D218,858	S	*	9/1970	Fellers et al.	.....	D12/338
3,971,535	A	*	7/1976	Jones	.....	244/46
D240,810	S	*	8/1976	Meyerhoff et al.	.....	D12/214
4,022,403	A	*	5/1977	Chiquet	.....	244/46
4,132,374	A	*	1/1979	Abell	.....	244/46
4,998,689	A	*	3/1991	Woodcock	.....	244/46

6,244,537	B1	*	6/2001	Rutherford	.....	244/7 A
6,601,795	B1	*	8/2003	Chen	.....	244/46
6,669,137	B1	*	12/2003	Chen	.....	244/7 R
6,923,404	B1	*	8/2005	Liu et al.	.....	244/46
7,014,142	B2	*	3/2006	Barocela et al.	.....	244/7 R
7,338,010	B2	*	3/2008	Corder et al.	.....	244/3.28
7,510,139	B2	*	3/2009	Walliser	.....	244/7 A
7,611,090	B2	*	11/2009	Oleshchuk et al.	.....	244/12.5
7,816,635	B2	*	10/2010	Fink	.....	244/3.28
8,089,034	B2	*	1/2012	Hammerquist	.....	244/3.28
2007/0095970	A1	*	5/2007	Richardson	.....	244/7 A
2008/0272244	A1	*	11/2008	Bjornenak et al.	.....	244/7 R
2009/0026321	A1	*	1/2009	Sarh et al.	.....	244/218
2010/0264260	A1	*	10/2010	Hammerquist	.....	244/49

\* cited by examiner

*Primary Examiner* — Martie K Holtje

(74) *Attorney, Agent, or Firm* — Morland C. Fischer

(57) **CLAIM**

The ornamental design for an air vehicle having rotatable and retractable pairs of wings, as shown and described.

**DESCRIPTION**

FIG. 1 is a perspective view showing the top, left side and front of an air vehicle having rotatable and retractable pairs of wings which forms my new design, wherein a first of the pairs of wings are shown rotated to a first position relative to one another and a second of the pairs of wings are shown in an extended position;

FIG. 2 is a top plan view thereof;

FIG. 3 is a left side elevational view thereof;

FIG. 4 is a right side elevational view thereof;

FIG. 5 is a bottom plan view thereof;

FIG. 6 is a front elevational view thereof;

FIG. 7 is a rear elevational view thereof;

FIG. 8 is a perspective view showing the top, left side and front thereof with the first pair of wings shown rotated to a second position relative to one another and the second pair of wings retracted; and,

FIG. 9 is a left side elevational view thereof.

**1 Claim, 5 Drawing Sheets**

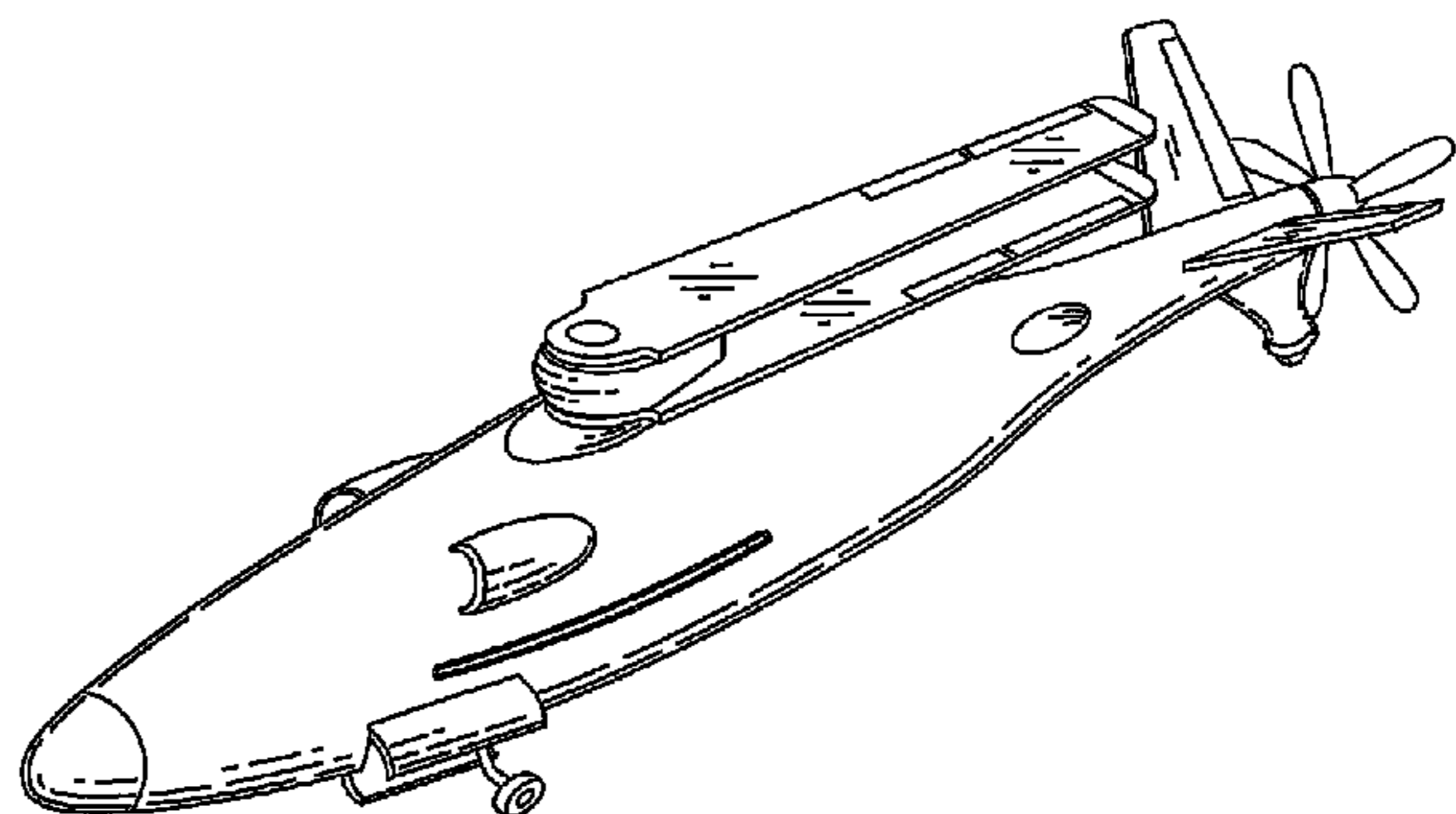
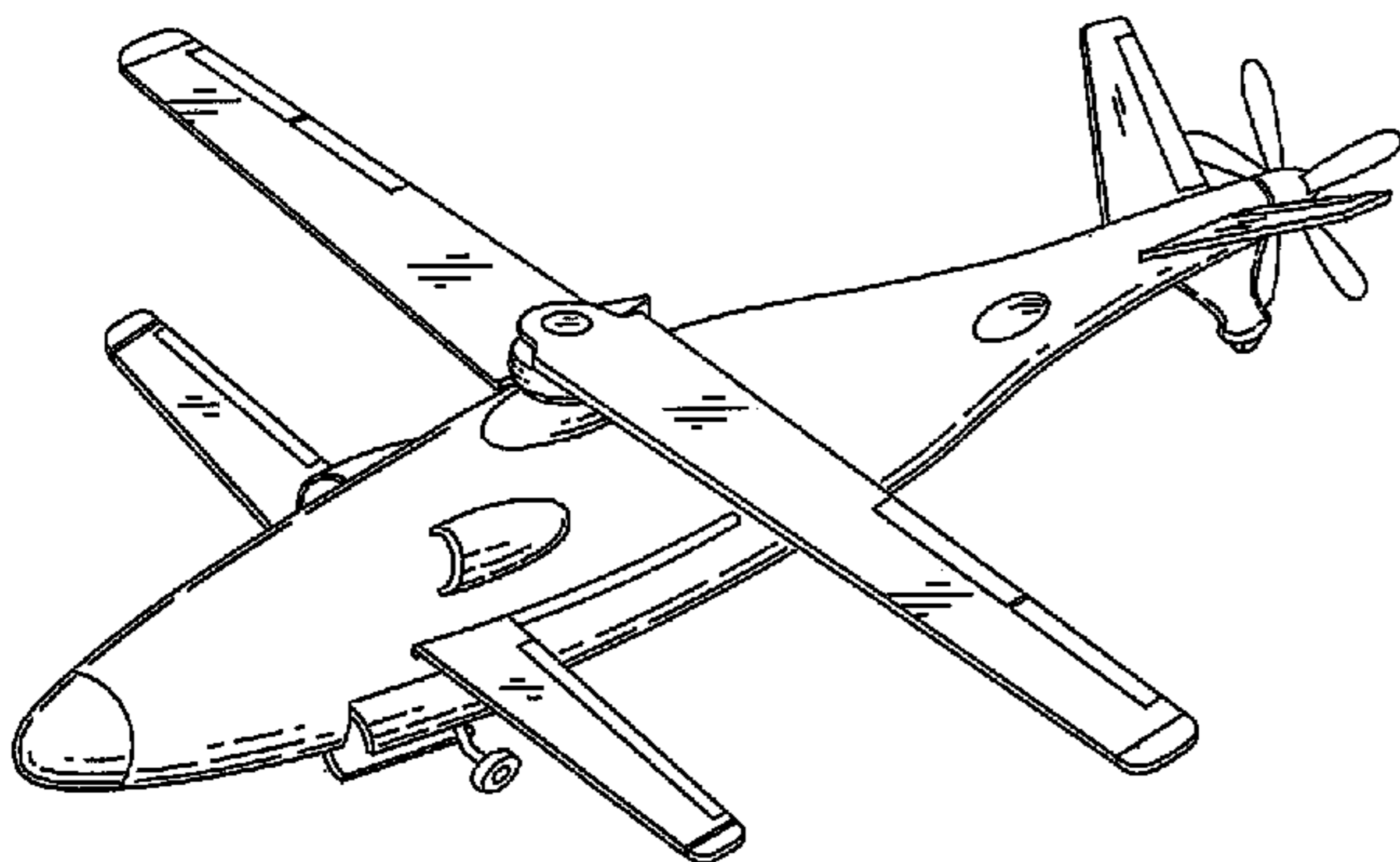

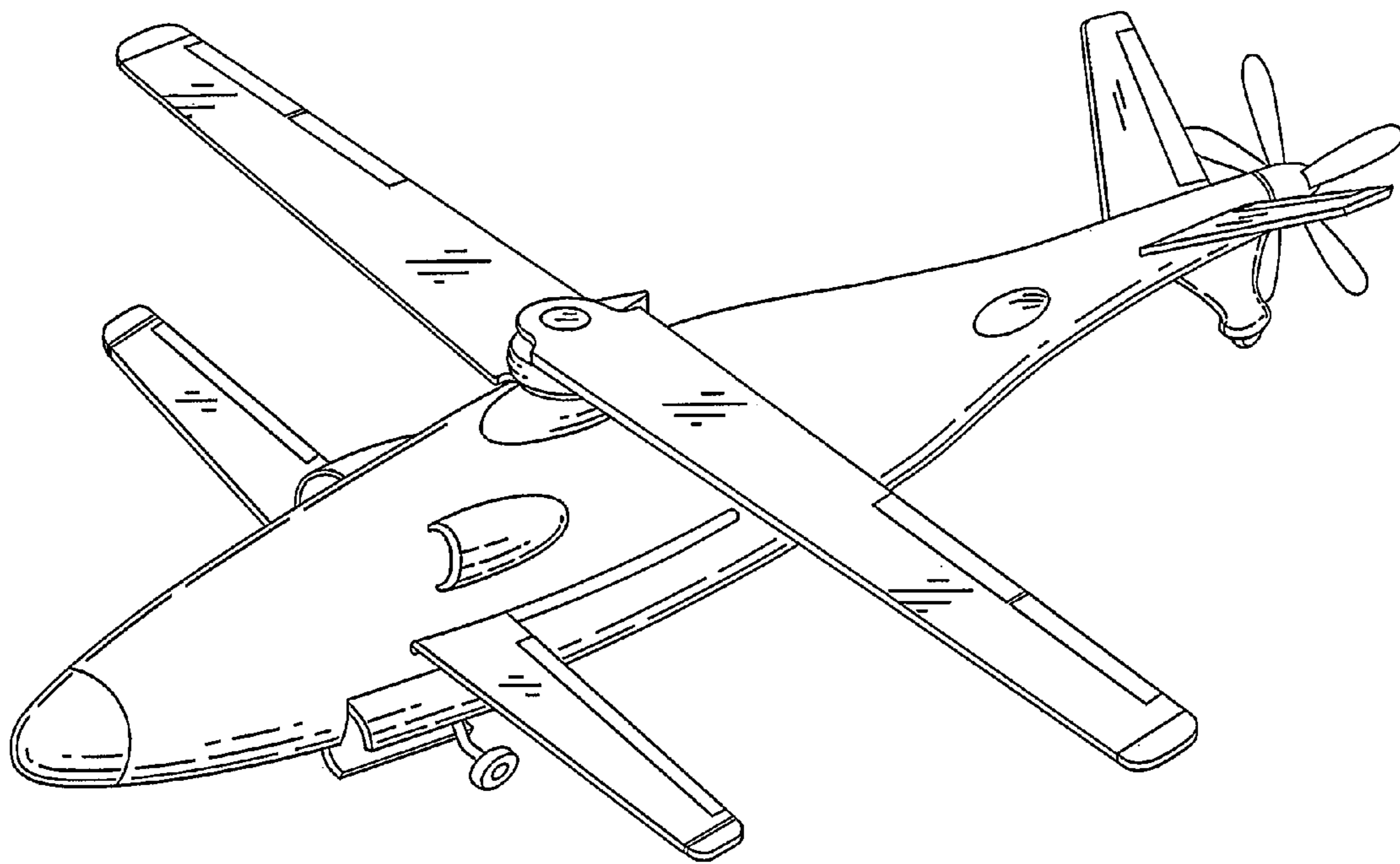

FIG. 1

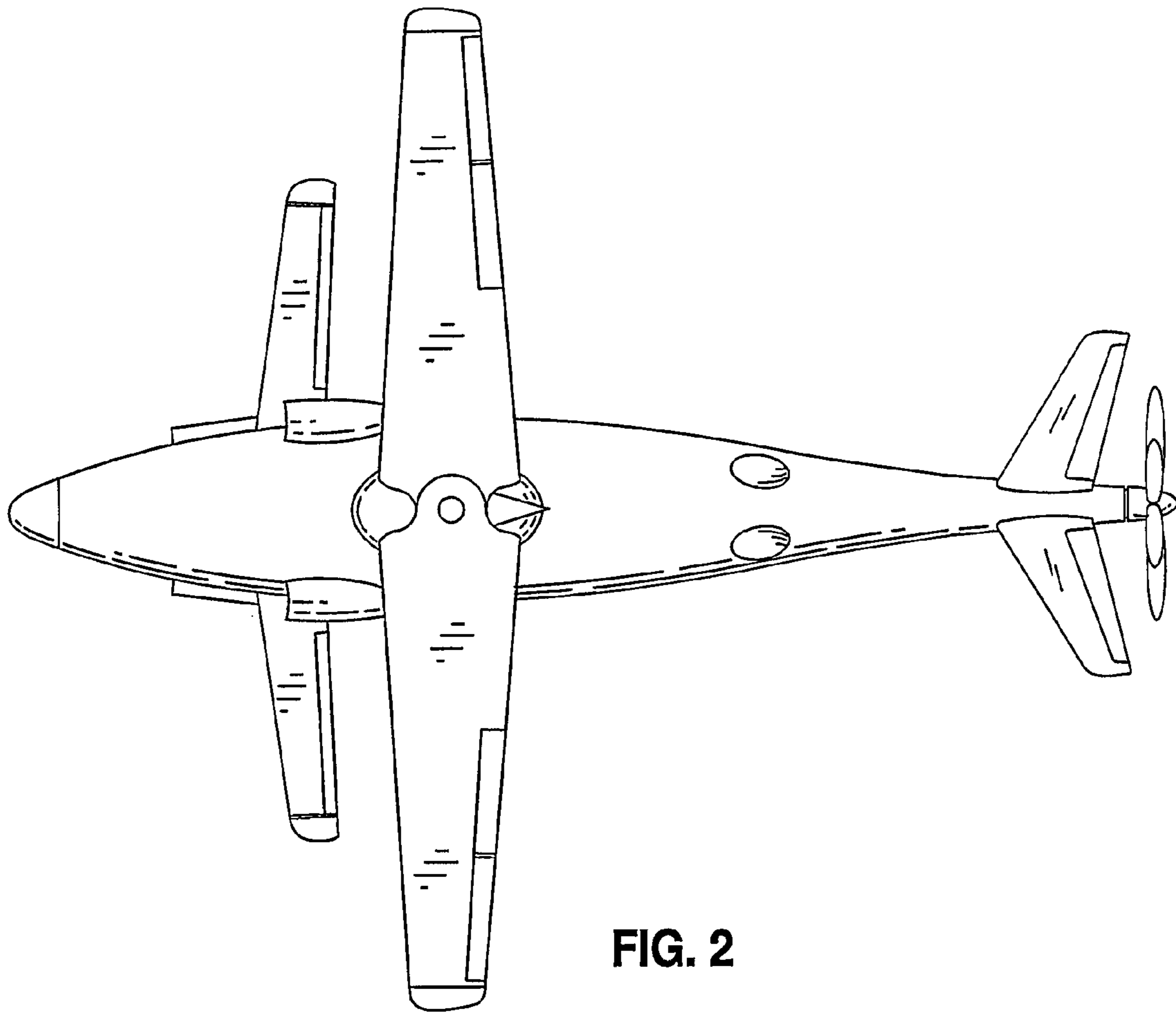

FIG. 2

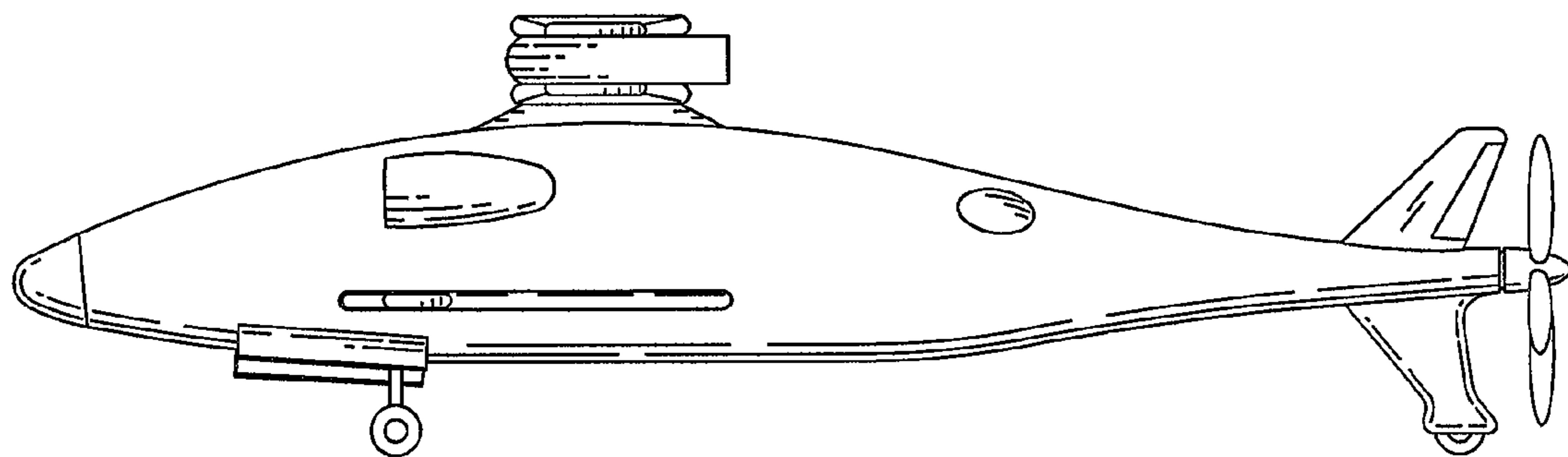

FIG. 3

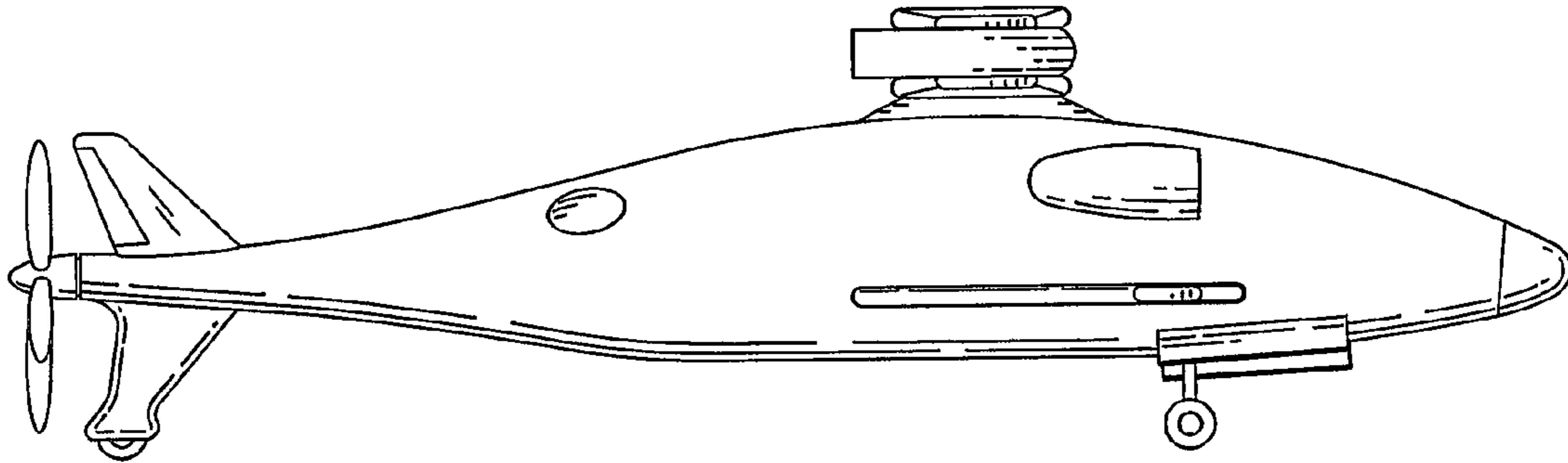

FIG. 4

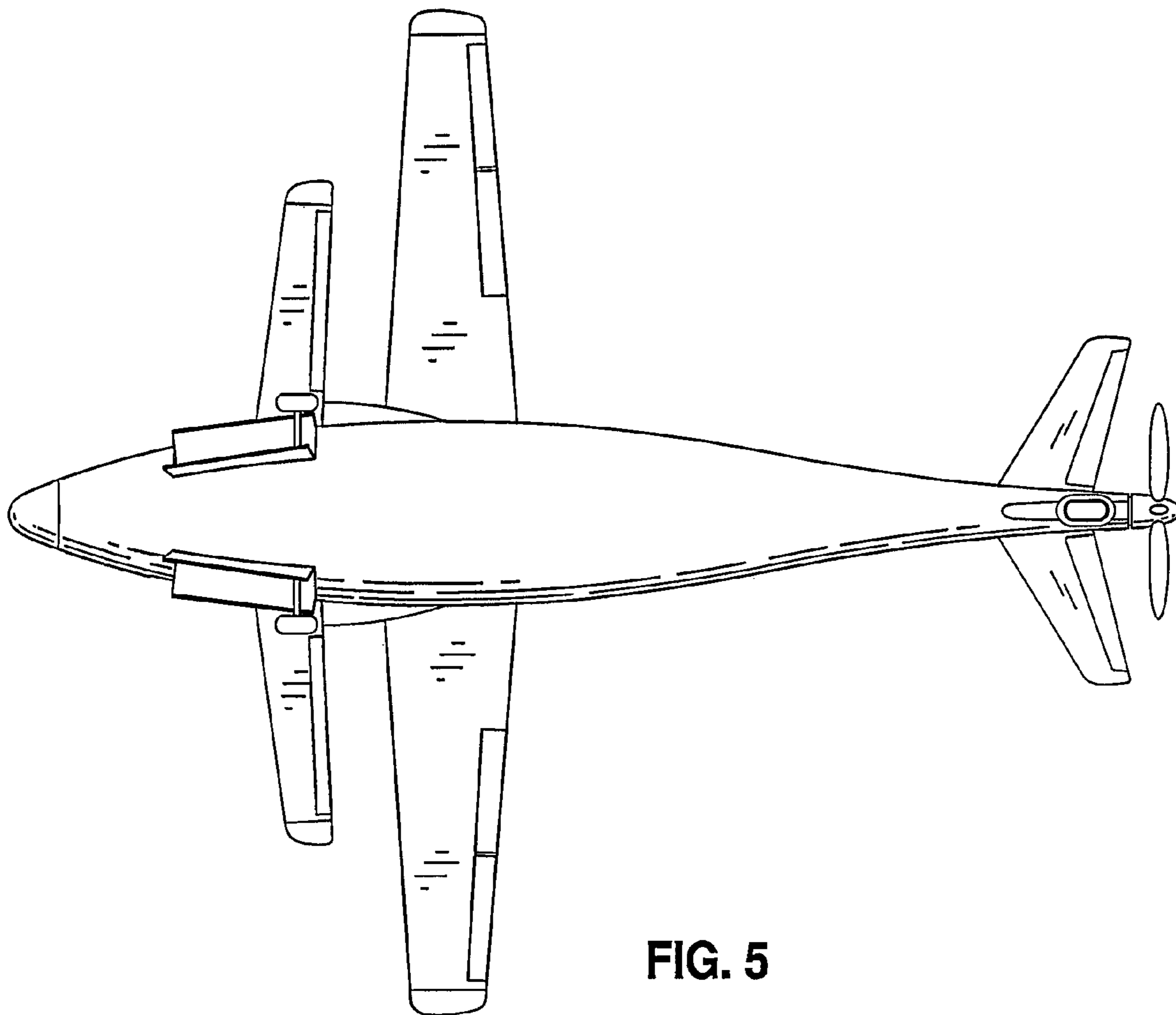

FIG. 5

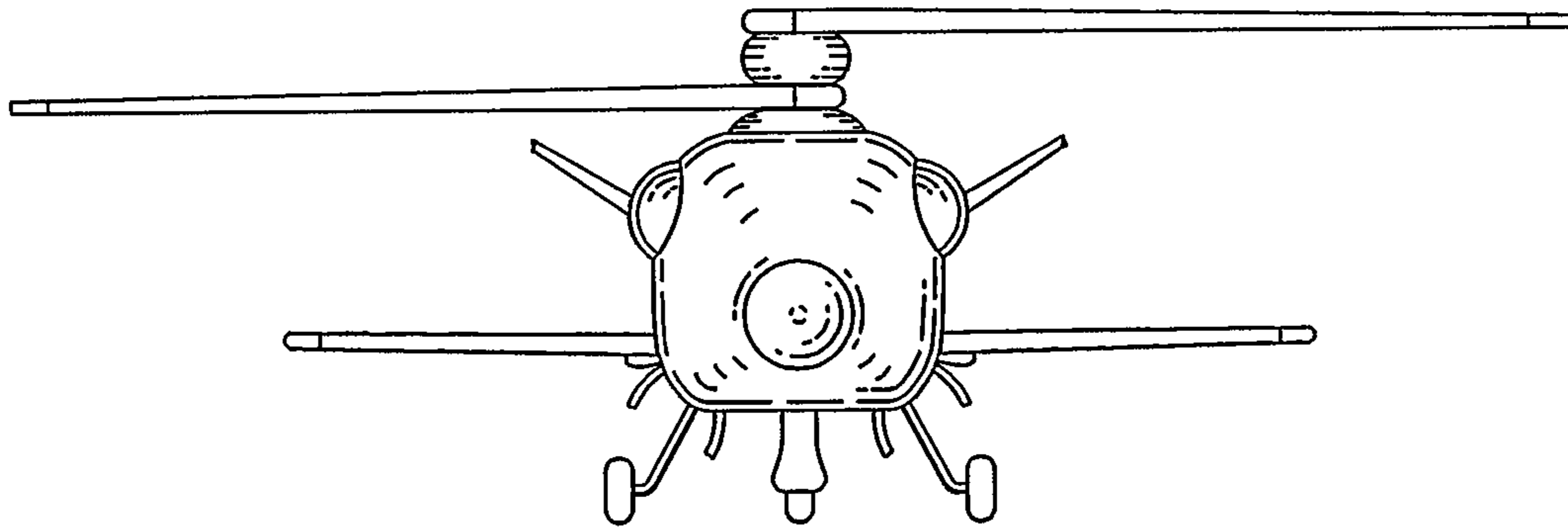

FIG. 6

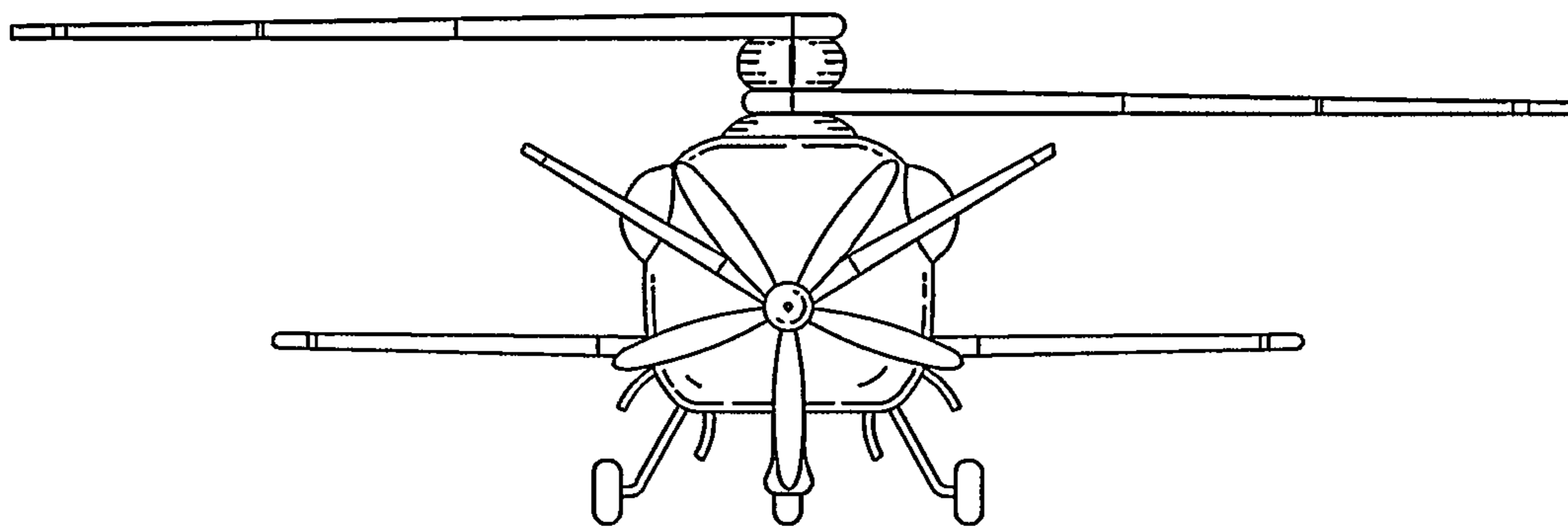

FIG. 7

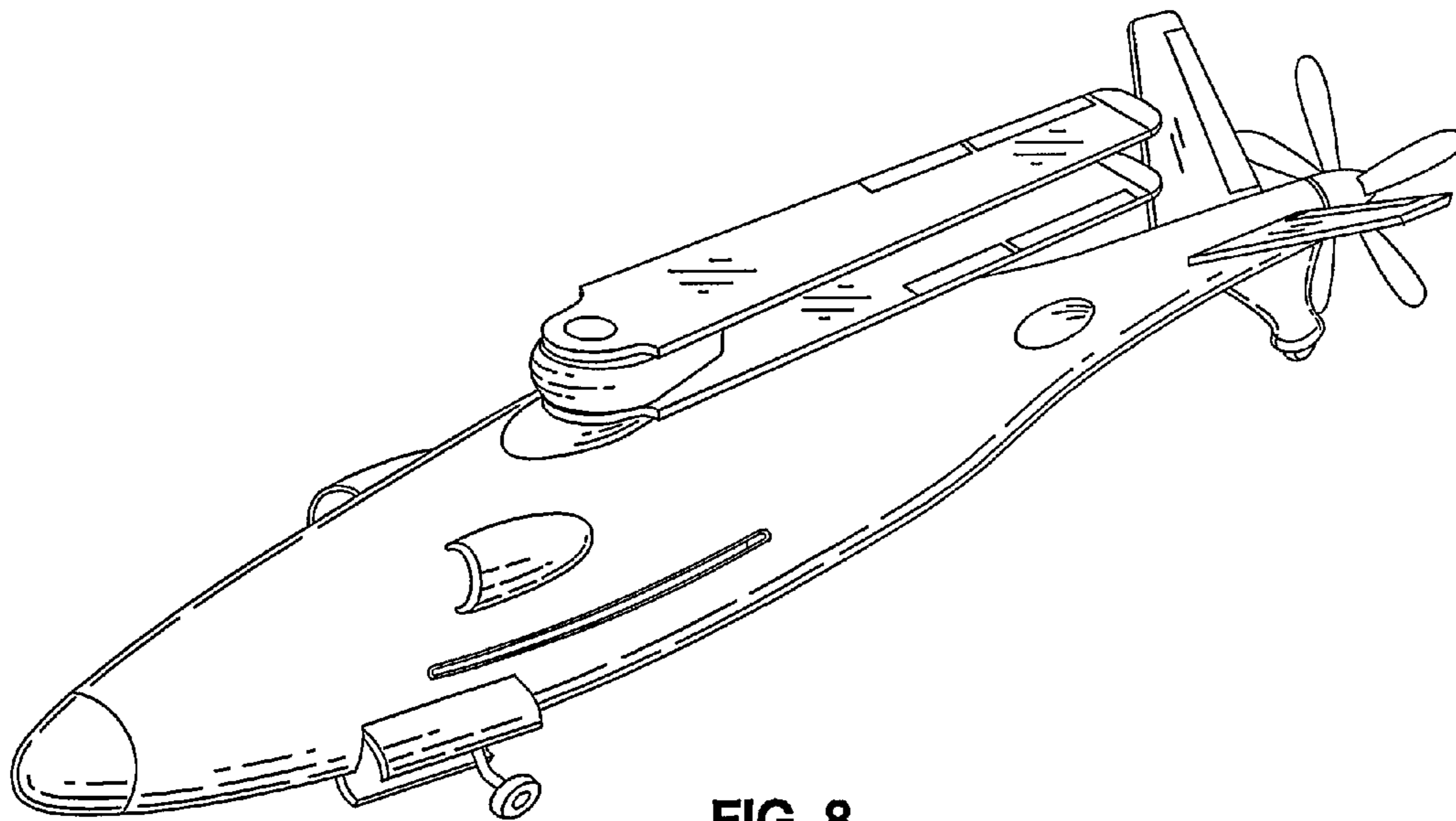

FIG. 8

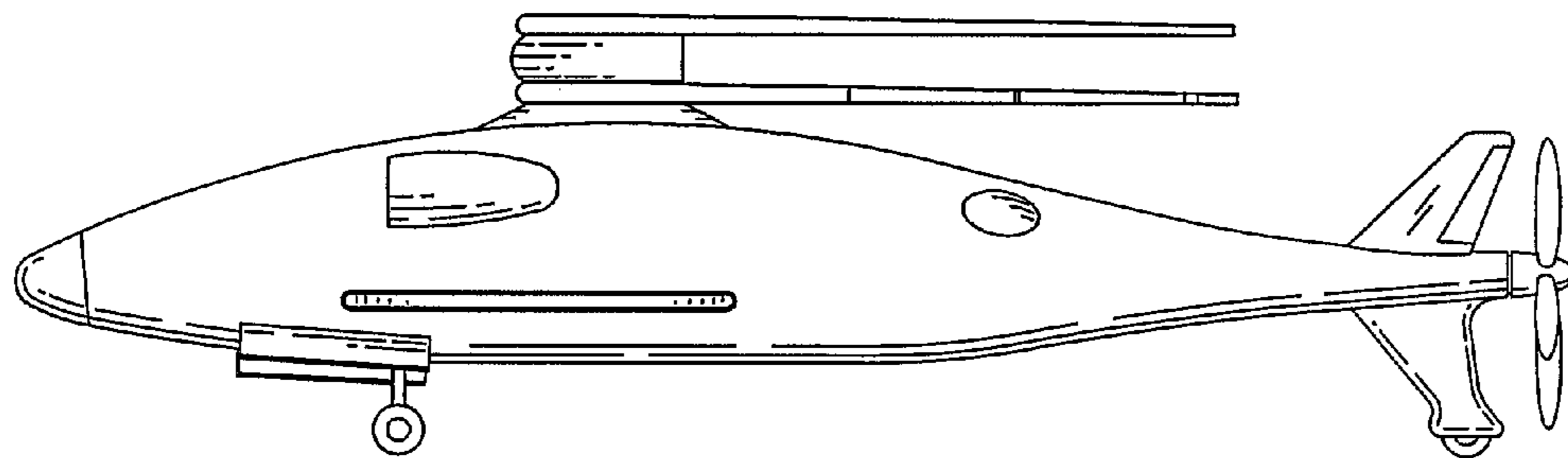

FIG. 9