

US00D710767S

(12) **United States Design Patent**
Heilaneh et al.

(10) **Patent No.:** **US D710,767 S**

(45) **Date of Patent:** **** Aug. 12, 2014**

(54) **VEHICLE BUMPER UNIT**

(71) Applicants: **Louis D. Heilaneh**, Lewisville, TX (US);
Derek Sancer, Corinth, TX (US); **Chris I. Ito**, Sugar Grove, IL (US);
Kunjithapadam Raghavendran, Denton, TX (US); **William J. Johnson**, Dallas, TX (US); **Scott D. Hite**, Pilot Point, TX (US)

D400,144 S 10/1998 Hellhake
D401,198 S 11/1998 Mueller
D403,636 S 1/1999 Meryman
D411,494 S 6/1999 Meryman
D412,689 S 8/1999 Onopa
D423,429 S 4/2000 Hickman
D429,669 S 8/2000 Cook

(Continued)

OTHER PUBLICATIONS

“Class Pays, Truck Models,” Peterbilt Motors Company, Denton, Texas, Mar. 2005, 24•page brochure.

(Continued)

(72) Inventors: **Louis D. Heilaneh**, Lewisville, TX (US);
Derek Sancer, Corinth, TX (US); **Chris I. Ito**, Sugar Grove, IL (US);
Kunjithapadam Raghavendran, Denton, TX (US); **William J. Johnson**, Dallas, TX (US); **Scott D. Hite**, Pilot Point, TX (US)

Primary Examiner — Melody Brown

(74) *Attorney, Agent, or Firm* — Christensen O’Connor Johnson Kindness PLLC

(73) Assignee: **PACCAR Inc**, Bellevue, WA (US)

(57) **CLAIM**

(**) Term: **14 Years**

The ornamental design for a vehicle bumper unit, as shown and described.

(21) Appl. No.: **29/450,727**

DESCRIPTION

(22) Filed: **Mar. 21, 2013**

(51) **LOC (10) Cl.** **12-16**

(52) **U.S. Cl.**
USPC **D12/169**

(58) **Field of Classification Search**
USPC D12/169, 216, 90–92, 86, 171, 196,
D12/163; 293/102, 113, 115, 117, 120;
296/180.1, 180.2

See application file for complete search history.

FIG. 1 is a top perspective view of a vehicle, bumper unit for a vehicle according to our new design;

FIG. 2 is bottom perspective of the vehicle bumper unit of FIG. 1;

FIG. 3 is a front view of the vehicle bumper unit of FIG. 1;

FIG. 4 is a top view of vehicle bumper unit of FIG. 1; and,

FIG. 5 is a bottom view of vehicle bumper unit of FIG. 1.

FIGS. 1-5 illustrate a first embodiment of our novel design suitable for use on the left side of a vehicle. Our novel design also includes a second embodiment suitable for use on the right side of a vehicle, which is mirror symmetrical to FIGS. 1-5 and therefore not separately illustrated.

The rear of the vehicle bumper unit is unornamented.

The broken lines immediately adjacent the shaded areas as depicted in the FIGURES, represent the bounds of the claimed design while all other broken lines are directed to environment and are for illustrative purposes only; the broken lines form no part of the claimed design.

(56) **References Cited**

U.S. PATENT DOCUMENTS

D248,156 S 6/1978 Tixier
D307,254 S 4/1990 Koske
D316,241 S 4/1991 Ray
D343,605 S 1/1994 Meryman
D364,371 S 11/1995 Ray
D381,946 S 8/1997 Delashaw
D391,212 S 2/1998 Meryman
D395,860 S 7/1998 Meryman

1 Claim, 3 Drawing Sheets

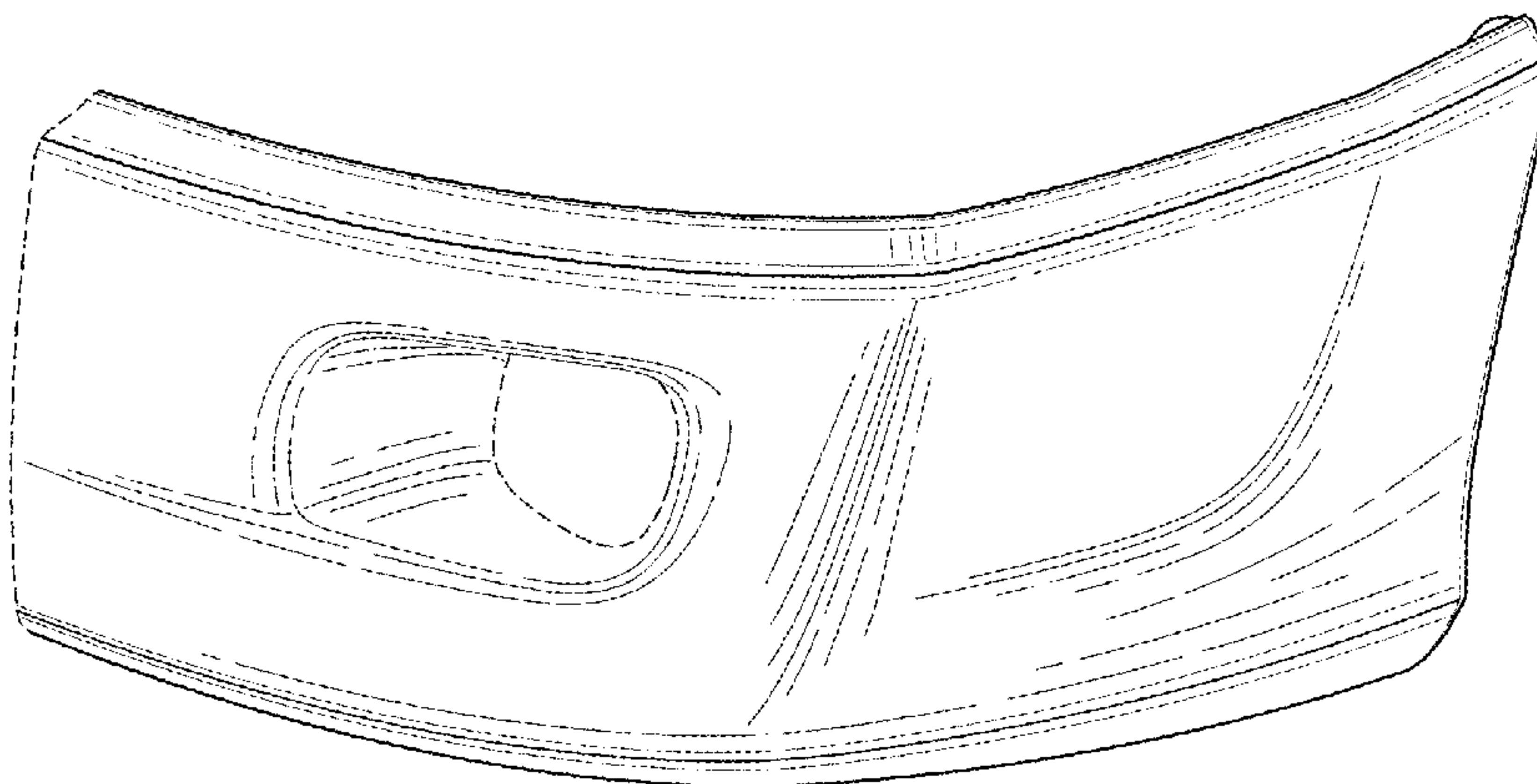

(56)

References Cited

U.S. PATENT DOCUMENTS

D442,132 S 5/2001 Weidhase
 D443,853 S 6/2001 Barraclough
 D450,277 S 11/2001 Onopa
 D458,565 S 6/2002 Maher
 D460,023 S 7/2002 Beigel
 D460,030 S 7/2002 Duckett
 D465,749 S 11/2002 Beigel
 D466,450 S 12/2002 Maher
 D466,847 S 12/2002 Waskow
 6,520,553 B2 2/2003 Muramatsu
 D471,494 S 3/2003 Chan
 D475,663 S 6/2003 Chiang
 D475,664 S 6/2003 Chiang
 D476,929 S 7/2003 Dozier
 D477,258 S 7/2003 Hayashi
 D478,027 S 8/2003 Chiang
 D478,028 S 8/2003 Chiang
 D482,302 S 11/2003 Dozier
 D483,707 S 12/2003 Satou
 D488,749 S 4/2004 Ikuma
 D490,749 S 6/2004 Satou
 D491,496 S 6/2004 Metros
 D491,848 S 6/2004 Metros
 D491,851 S 6/2004 Perfetti
 D492,627 S 7/2004 Metros
 D492,628 S 7/2004 Bond
 D492,801 S 7/2004 Metros
 D494,898 S 8/2004 Metros
 D497,577 S 10/2004 Metros
 D497,581 S 10/2004 Conway
 D497,851 S 11/2004 Metros
 D498,716 S 11/2004 Maeda
 D501,809 S 2/2005 Metros
 D504,850 S 5/2005 Gunter
 D512,351 S 12/2005 Hattori
 D515,989 S 2/2006 Choi
 D518,424 S 4/2006 Clark
 D519,067 S 4/2006 Steere
 D519,068 S 4/2006 Clark
 D519,069 S 4/2006 Clark
 D530,653 S 10/2006 Angelo
 D531,940 S 11/2006 McCuller
 D540,722 S 4/2007 Angelo
 D543,914 S 6/2007 Lai
 D545,248 S 6/2007 Angelo
 D551,601 S 9/2007 Tabata
 D563,840 S 3/2008 Simons
 D565,484 S 4/2008 Johnson
 D584,664 S 1/2009 Johnson
 D584,665 S 1/2009 Johnson
 D588,507 S 3/2009 Opfer
 D589,846 S 4/2009 Tanaka

D595,624 S 7/2009 Wagner
 D612,778 S 3/2010 Beigel
 D621,752 S 8/2010 Angelo
 D626,470 S 11/2010 Komuro
 D633,419 S 3/2011 Peltola
 D645,799 S 9/2011 Beigel
 D647,013 S 10/2011 Ito
 D653,999 S 2/2012 Peltola
 D655,652 S 3/2012 Hanson
 D671,049 S 11/2012 Davidson
 D671,051 S 11/2012 Davidson
 D684,508 S * 6/2013 Peltola et al. D12/169
 2010/0181786 A1 7/2010 Tejler

OTHER PUBLICATIONS

“Class Pays,” Peterbilt Motors Company, Denton, Texas, Nov. 1998, 10•page brochure.
 “Class Pays,” Peterbilt Motors Company, Denton, Texas, Sep. 1997, 10•page brochure.
 “Kenworth Truck Models,” Kenworth Truck Company, Kirkland, Washington, 2010, 16•page brochure.
 “Model 378,” Peterbilt Motors Company, Denton, Texas, Mar. 1998, 3•page brochure.
 “Model 387,” Peterbilt Motors Company, Denton, Texas, Oct. 2002, 2•page brochure.
 “T2000,” Kenworth Truck Company, Kirkland, Washington, 1999, 20•page brochure.
 “T2000,” Kenworth Truck Company, Kirkland, Washington, 2002, 20•page brochure.
 “T2000,” Kenworth Truck Company, Kirkland, Washington, 2005, 20•page brochure.
 “T300,” Kenworth Truck Company, Kirkland, Washington, 1997, 5•page brochure.
 “T440,” Kenworth Truck Company, Kirkland, Washington, 2010, 2•page brochure.
 “T440,” Kenworth Truck Company, Kirkland, Washington, 2010, 6•page brochure.
 “T470,” Kenworth Truck Company, Kirkland, Washington, 2010, 6•page brochure.
 “T600,” Kenworth Truck Company, Kirkland, Washington, 2002, 28•page brochure.
 “T600,” Kenworth Truck Company, Kirkland, Washington, 2005, 24•page brochure.
 “T660,” Kenworth Truck Company, Kirkland, Washington, 2007, 36•page brochure.
 “T660,” Kenworth Truck Company, Kirkland, Washington, 2009, 36•page brochure.
 “T700,” Kenworth Truck Company, Kirkland, Washington, 2010, 6•page brochure.
 “T800B,” Kenworth Truck Company, Kirkland, Washington, 1993, 8•page brochure.

* cited by examiner

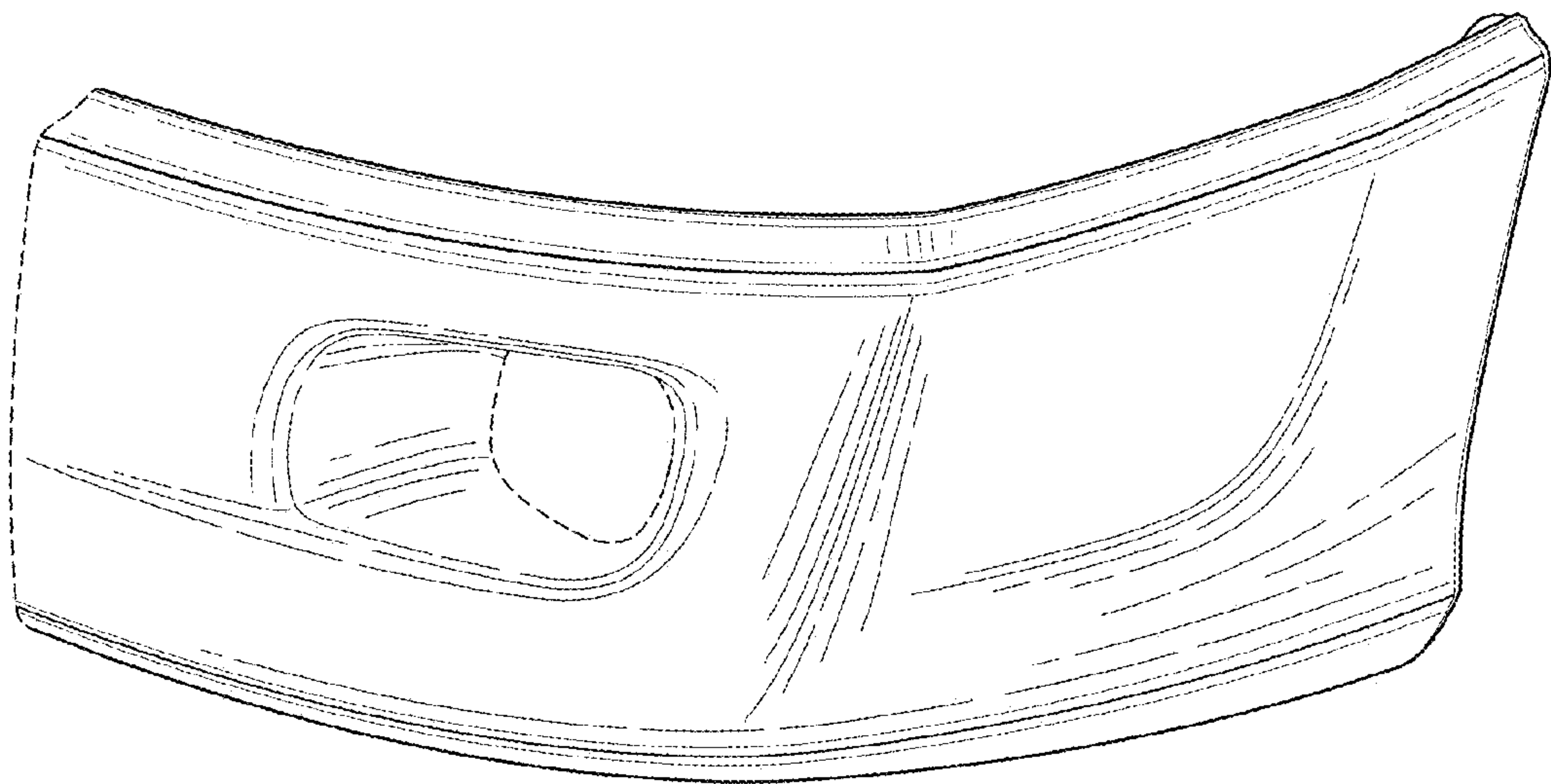

Fig. 1.

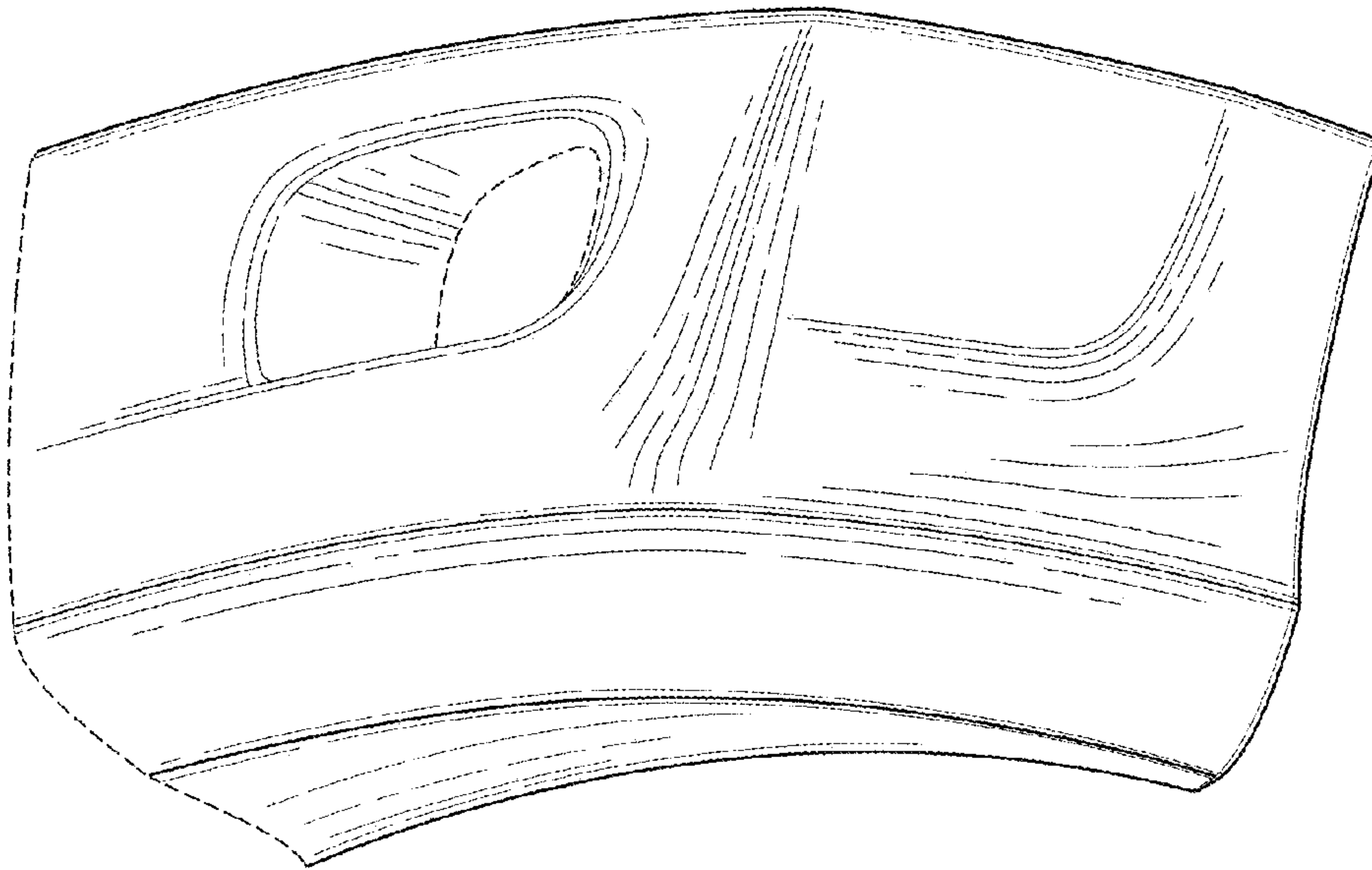

Fig. 2.

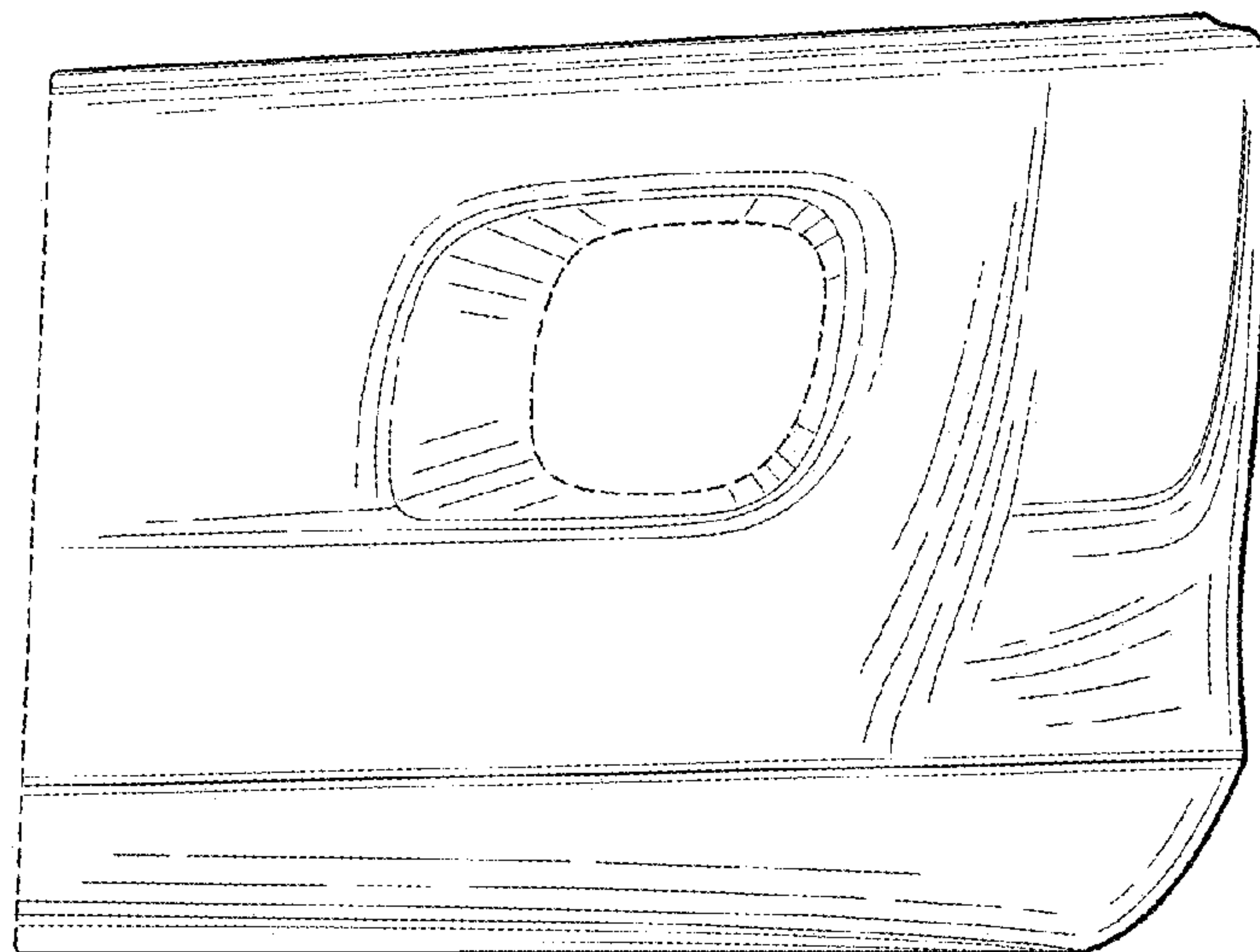

Fig. 3.

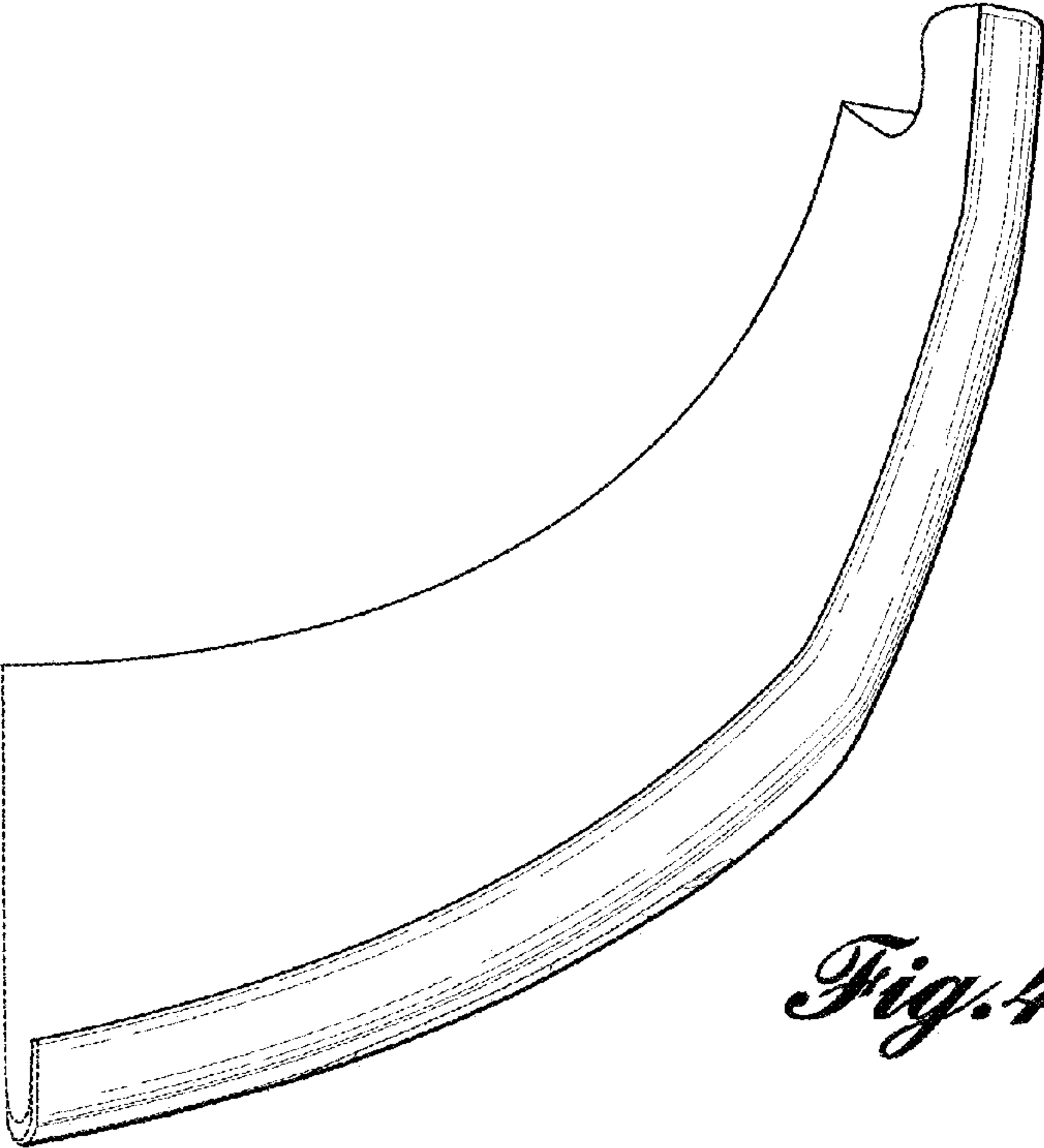

Fig. 4.

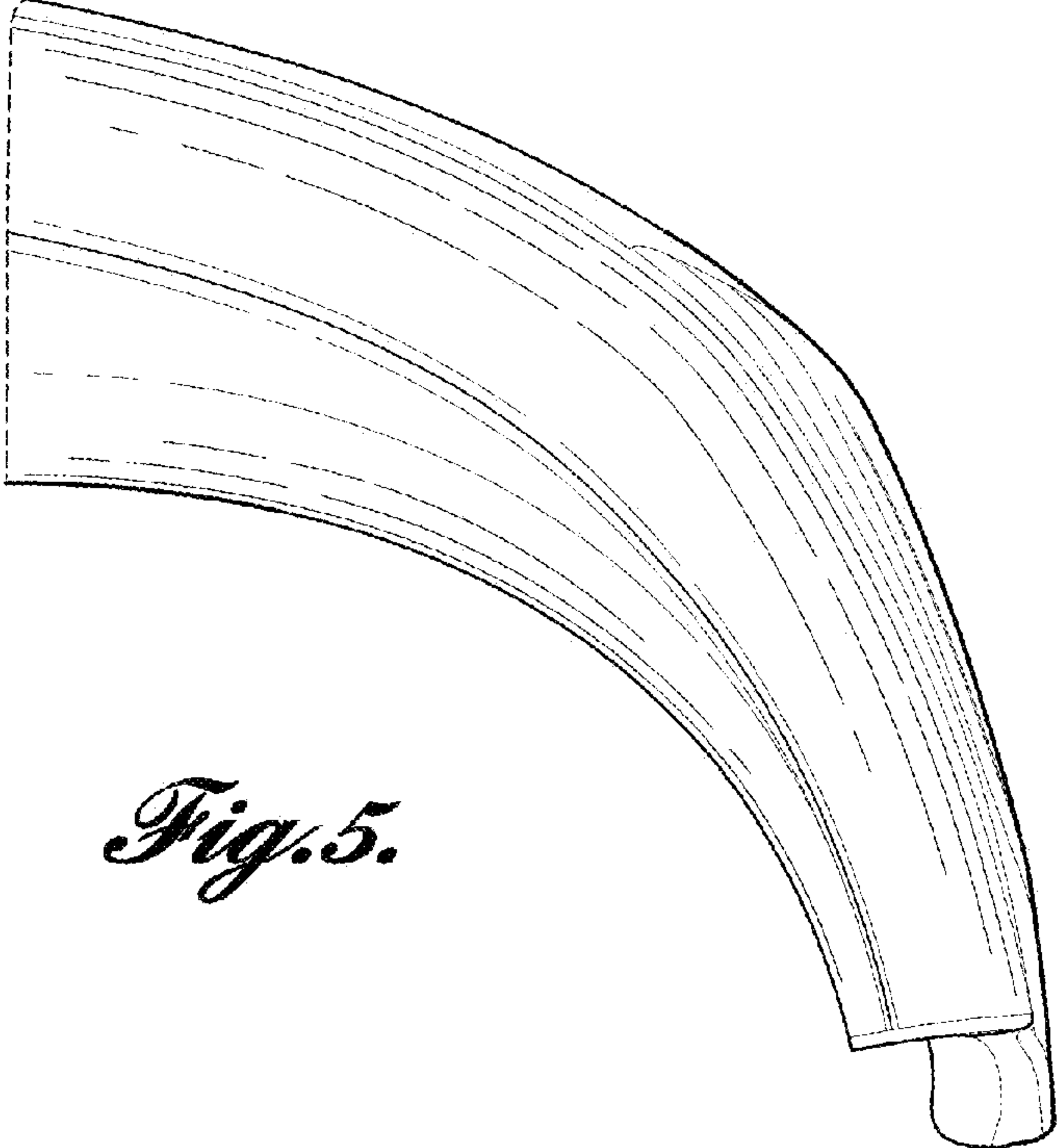

Fig. 5.

UNITED STATES PATENT AND TRADEMARK OFFICE
CERTIFICATE OF CORRECTION

PATENT NO. : D710,767 S
APPLICATION NO. : 29/450727
DATED : August 12, 2014
INVENTOR(S) : L. D. Heilaneh et al.

Page 1 of 1

It is certified that error appears in the above-identified patent and that said Letters Patent is hereby corrected as shown below:

On the Title Page

COLUMN

LINE

item (57) Abstract Pg. 1, col. 2	Description 1 of text	“vehicle, bumper” should read --vehicle bumper--
item (57) Abstract Pg. 1, col. 2	Description 6 of text	“of vehicle bumper unit of” should read --of the vehicle bumper unit of--
item (57) Abstract Pg. 1, col. 2	Description 7 of text	“of vehicle bumper unit of” should read --of the vehicle bumper unit of--

Signed and Sealed this
Second Day of December, 2014



Michelle K. Lee
Deputy Director of the United States Patent and Trademark Office