



US00D710512S

(12) **United States Design Patent**  
**Kitayama**

(10) **Patent No.:** **US D710,512 S**

(45) **Date of Patent:** **\*\* Aug. 5, 2014**

(54) **PUNCTURE ADAPTER FOR ULTRASONIC PROBE**

(71) Applicants: **Kabushiki Kaisha Toshiba**, Tokyo (JP);  
**Toshiba Medical Systems Corporation**,  
Otawara (JP)

(72) Inventor: **Masahiko Kitayama**, Mitaka (JP)

(73) Assignees: **Kabushiki Kaisha Toshiba**, Minato-Ku,  
Tokyo (JP); **Toshiba Medical Systems Corporation**,  
Otawara-Shi, Tochigi-Ken (JP)

(\*\*) Term: **14 Years**

(21) Appl. No.: **29/464,669**

(22) Filed: **Aug. 20, 2013**

(30) **Foreign Application Priority Data**

Feb. 21, 2013 (JP) ..... 2013-003518

(51) **LOC (10) Cl.** ..... **24-01**

(52) **U.S. Cl.**  
USPC ..... **D24/187**

(58) **Field of Classification Search**

USPC ..... D24/128, 140, 158, 164, 165, 167, 170,  
D24/186-187, 133, 130; D10/57, 60, 78,  
D10/80; 600/407, 461, 446, 439; 378/98.7,  
378/98.8, 189; 606/130

See application file for complete search history.

(56) **References Cited**

**U.S. PATENT DOCUMENTS**

4,899,756 A \* 2/1990 Sonek ..... 600/461  
5,623,931 A \* 4/1997 Wung et al. .... 600/461  
5,758,650 A \* 6/1998 Miller et al. .... 600/567  
5,924,992 A \* 7/1999 Park et al. .... 600/461  
5,941,889 A \* 8/1999 Cermak ..... 606/130  
D424,693 S \* 5/2000 Pruter ..... D24/130  
6,379,307 B1 \* 4/2002 Filly et al. .... 600/461

6,475,152 B1 \* 11/2002 Kelly et al. .... 600/461  
7,635,336 B1 \* 12/2009 Pruter ..... 600/461  
D643,923 S \* 8/2011 Senda ..... D24/128  
D672,038 S \* 12/2012 Frey ..... D24/140  
2002/0156376 A1 \* 10/2002 Wang et al. .... 600/439

**FOREIGN PATENT DOCUMENTS**

JP 1285346 11/2006

\* cited by examiner

*Primary Examiner* — T. Chase Nelson

*Assistant Examiner* — Mark Cavanna

(74) *Attorney, Agent, or Firm* — Banner & Witcoff, Ltd

(57) **CLAIM**

The ornamental design for a puncture adapter for ultrasonic probe, as shown and described.

**DESCRIPTION**

FIG. 1 is a front, top and left side perspective view of a puncture adapter for ultrasonic probe, showing my new design;

FIG. 2 is a front, top and right side perspective view thereof; FIG. 3 is a front view thereof, the opposite side being a mirror image thereof;

FIG. 4 is a right side view thereof;

FIG. 5 is a left side view thereof;

FIG. 6 is a top view thereof;

FIG. 7 is a bottom view thereof;

FIG. 8 is a cross sectional view thereof, taken along the line 8-8 in FIG. 6;

FIG. 9 is a partial enlarged view thereof, taken along the line 9-9 in FIG. 3;

FIG. 10 is a partial enlarged view thereof, taken along the line 10-10 in FIG. 6; and,

FIG. 11 is a partial enlarged view thereof, taken along the line 11-11 in FIG. 1.

The broken lines shown in FIGS. 9-11 are for environmental purposes only and form no part of the claimed design.

**1 Claim, 5 Drawing Sheets**

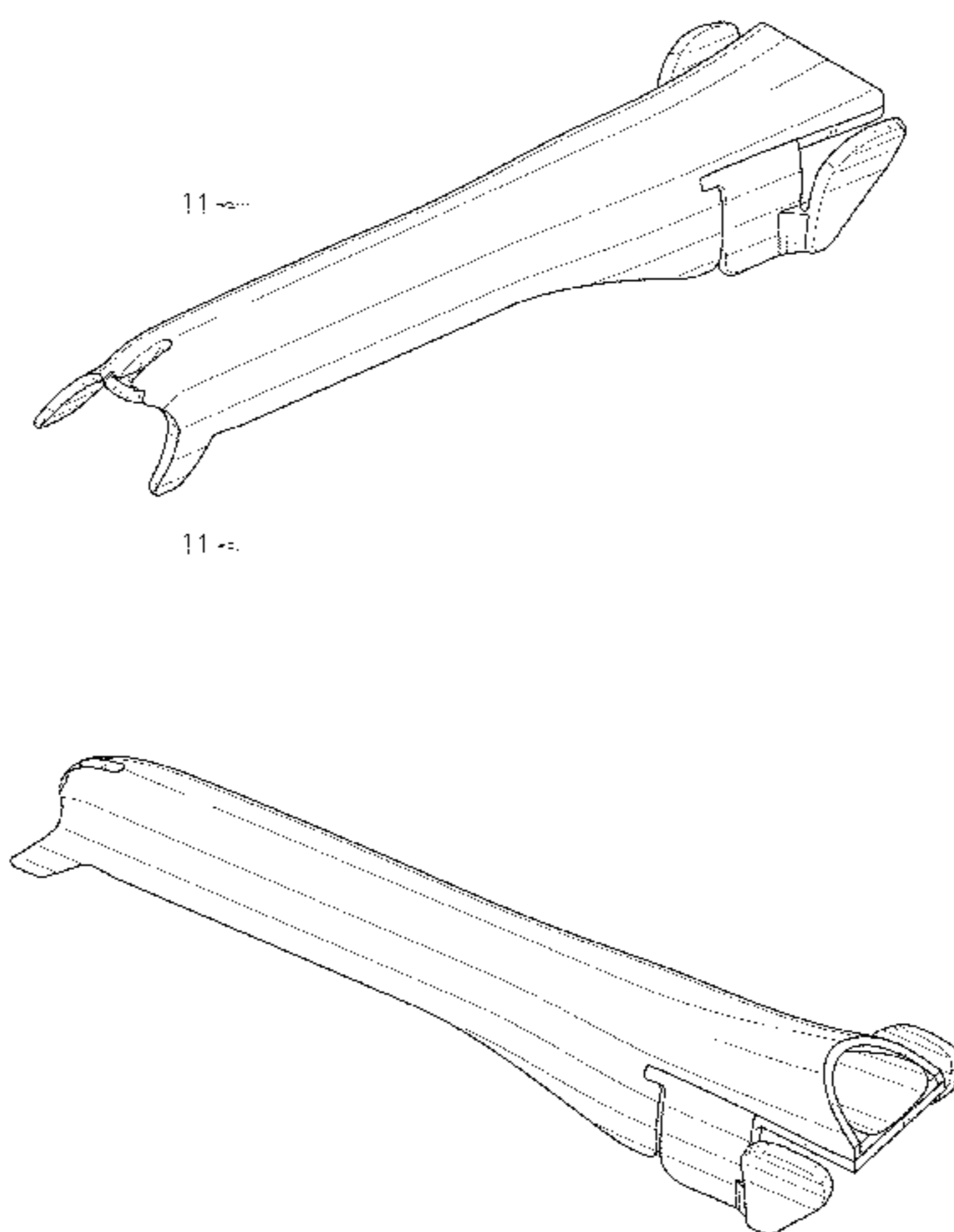

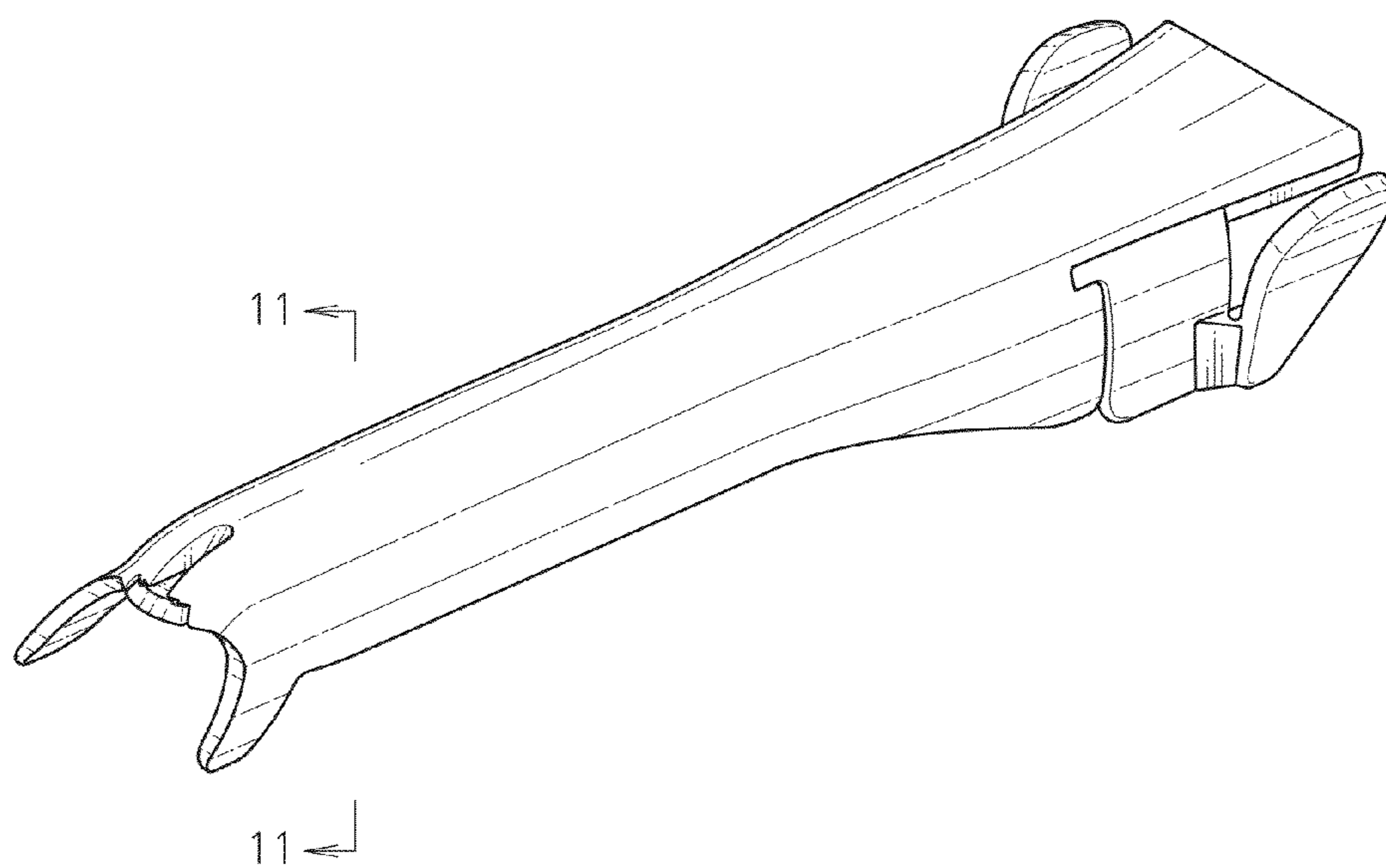

FIG. 1

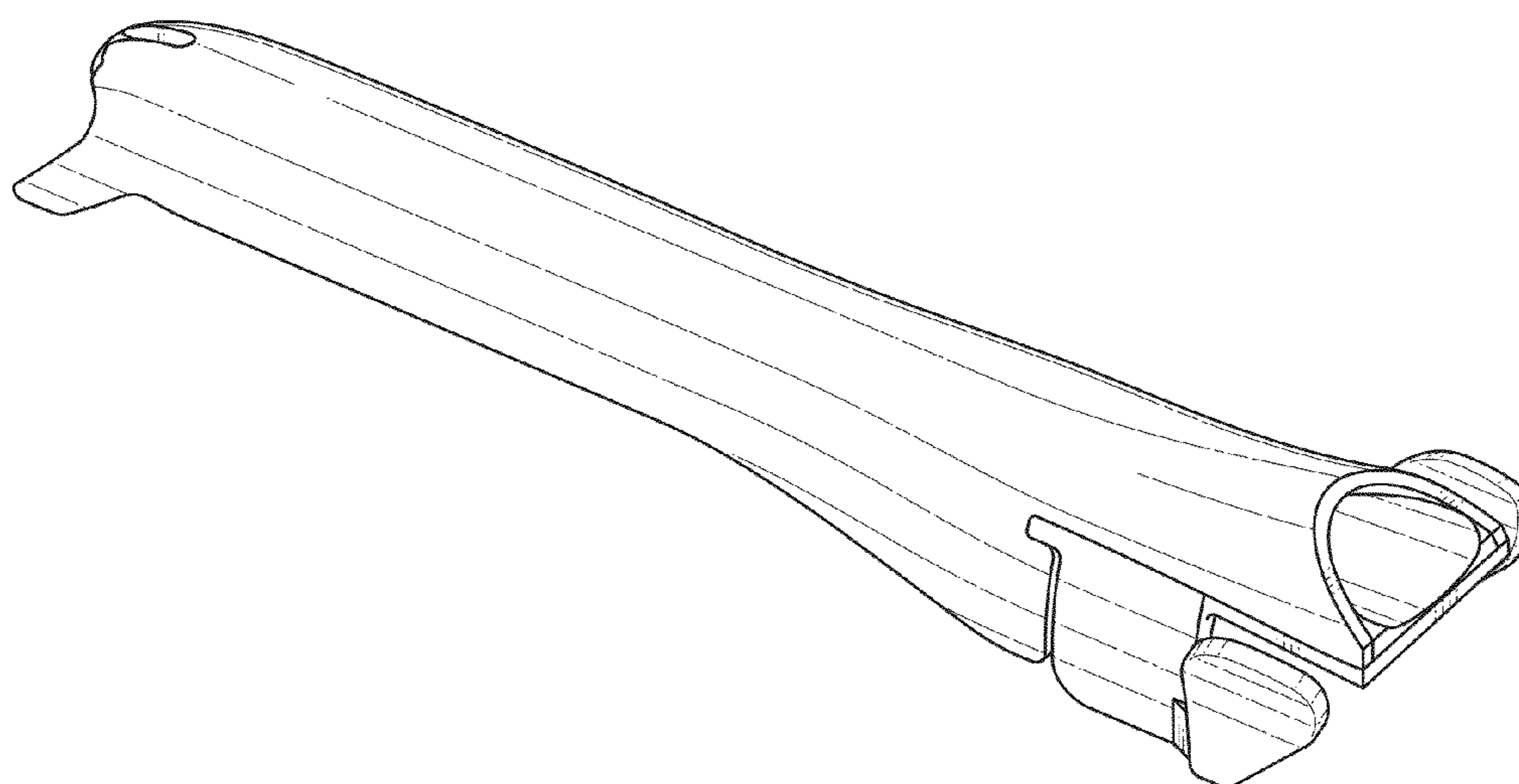

FIG. 2

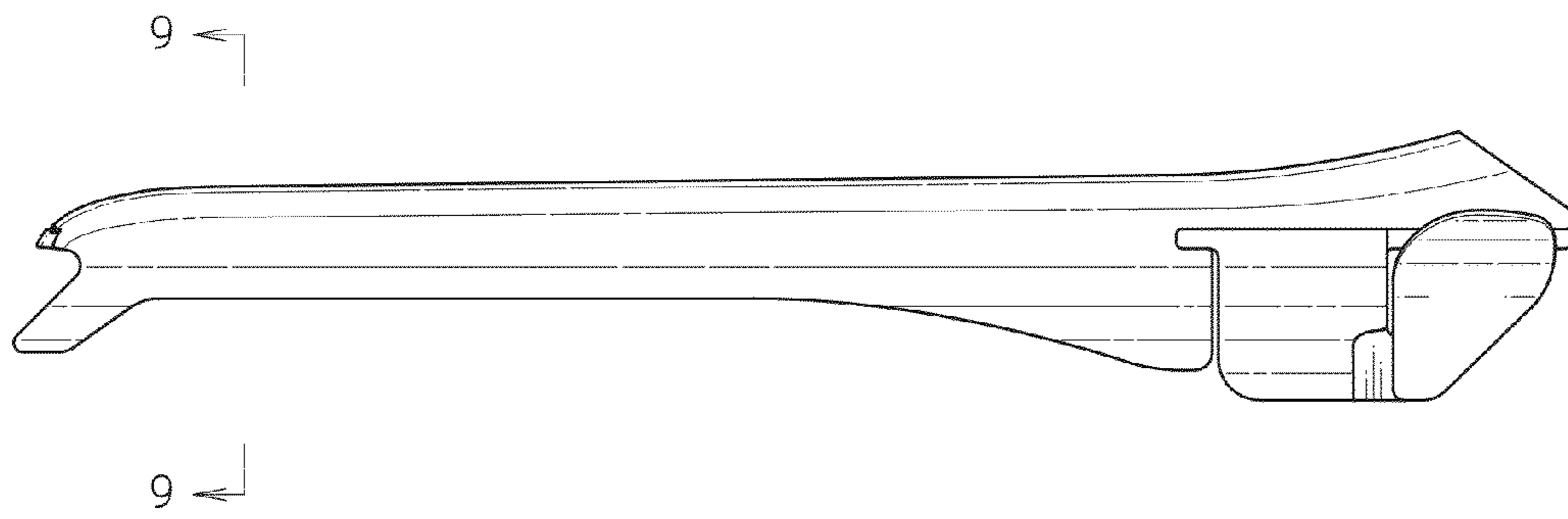

FIG. 3

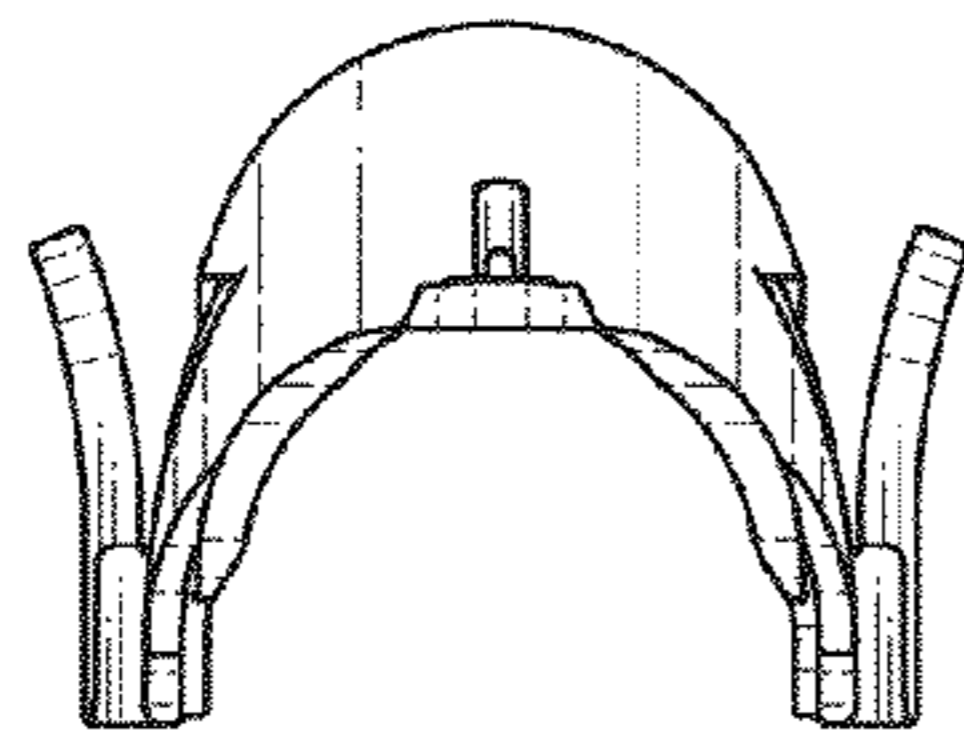

FIG. 5

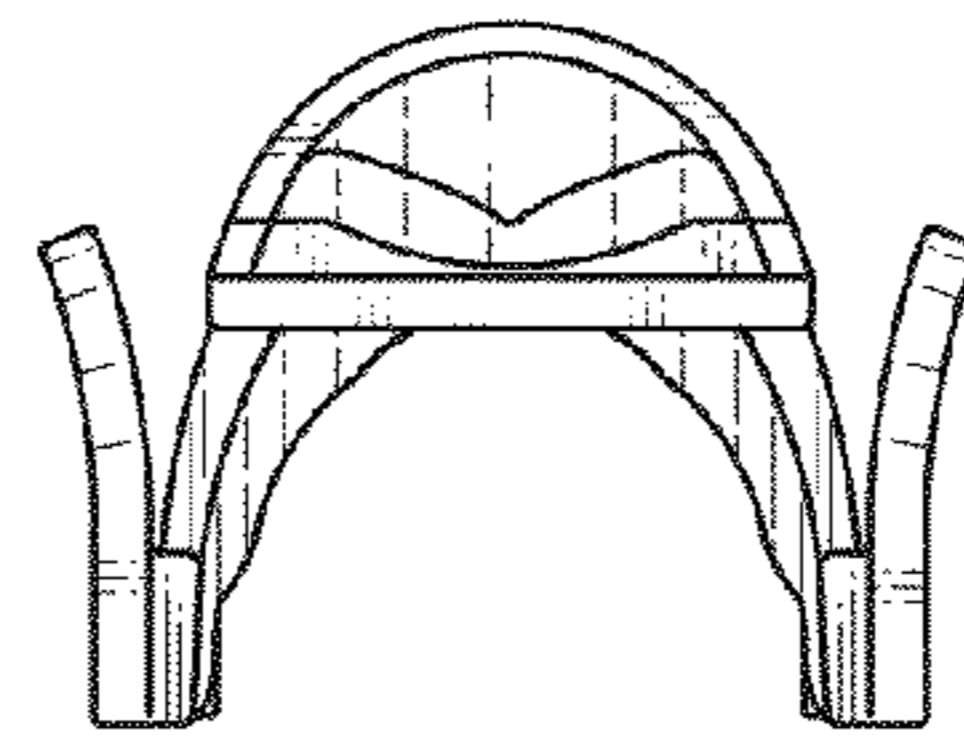

FIG. 4

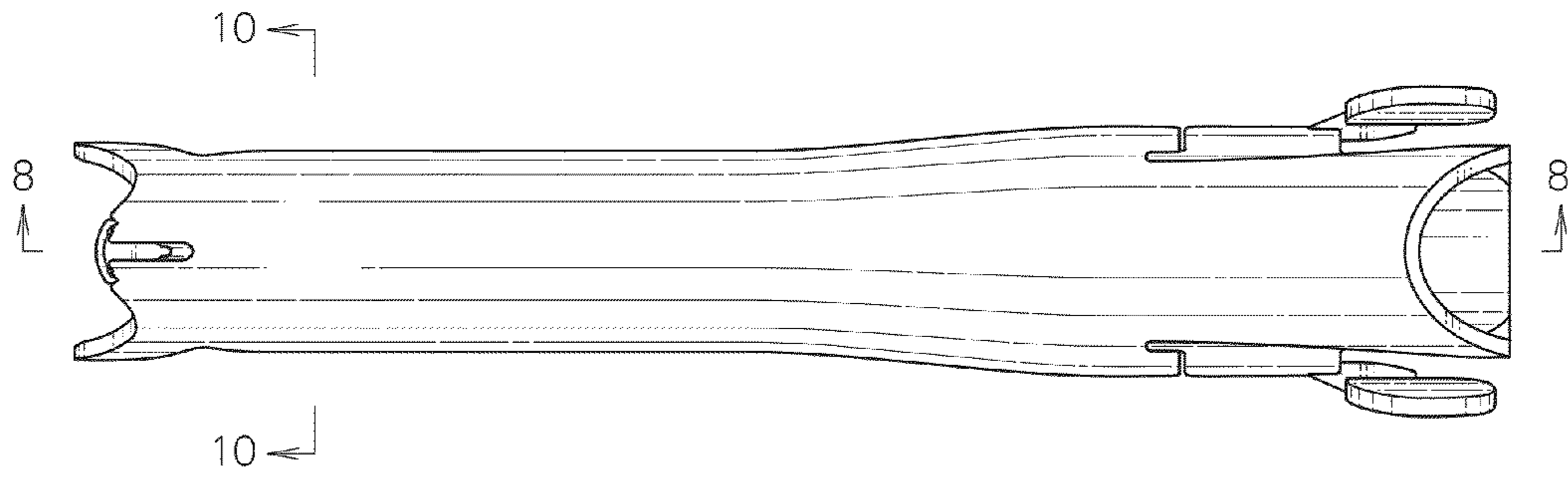

FIG. 6

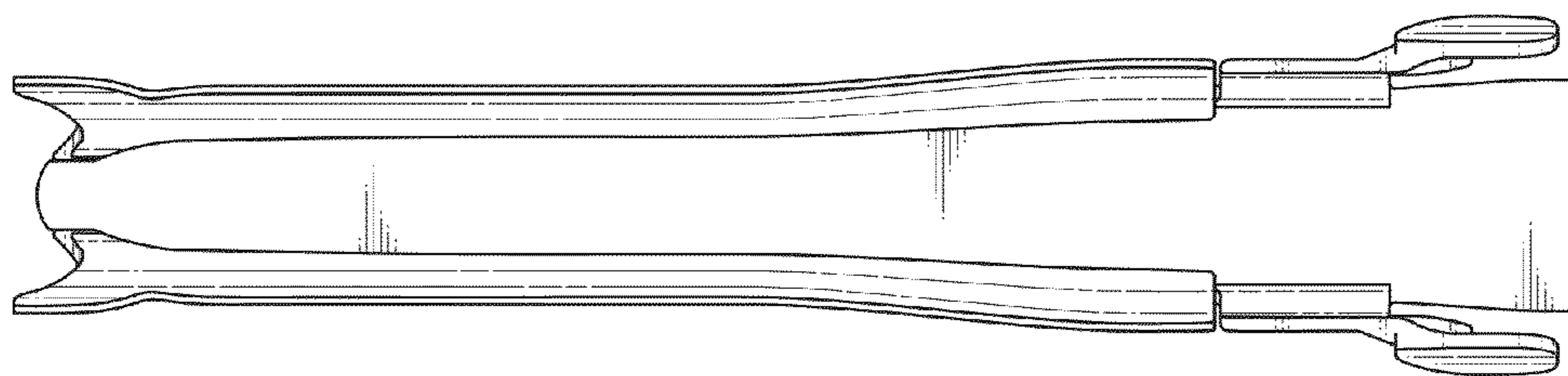

FIG. 7

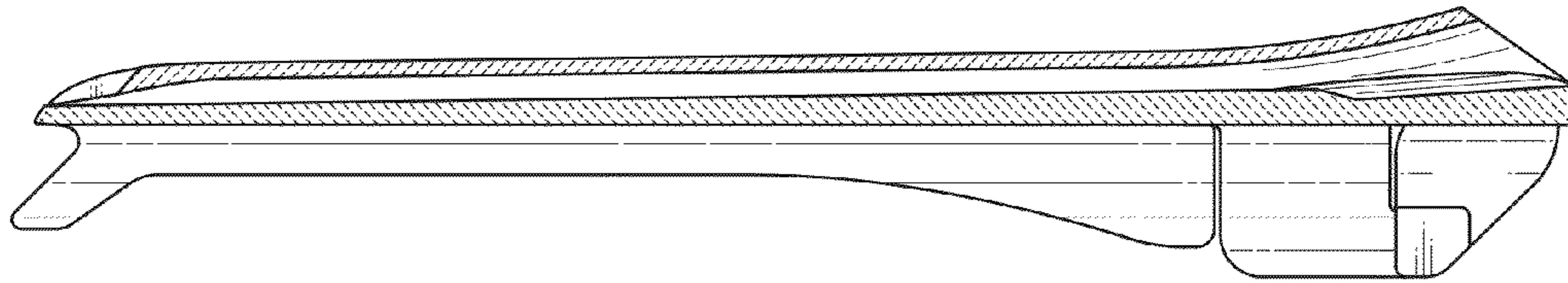

FIG. 8

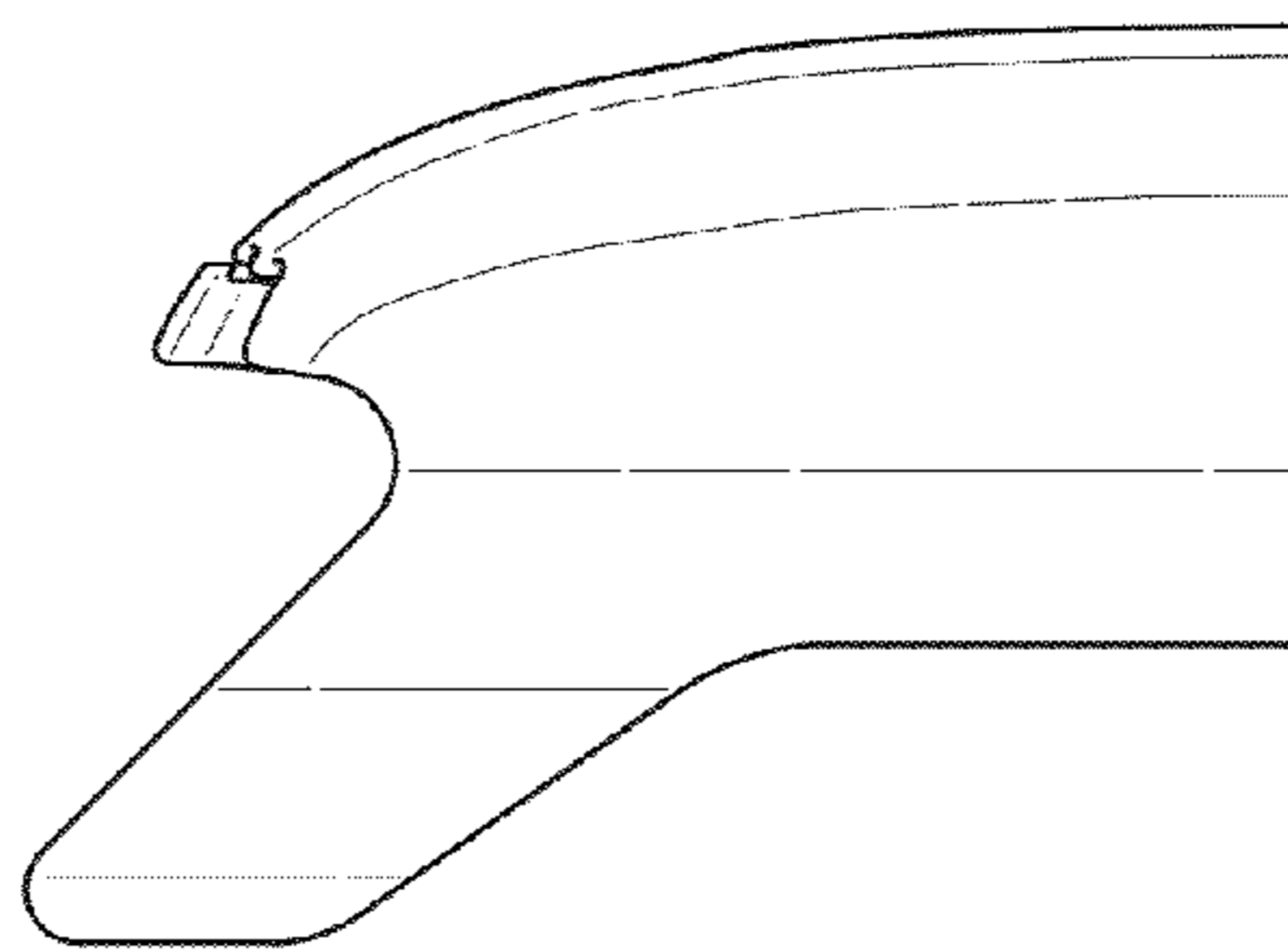

FIG. 9

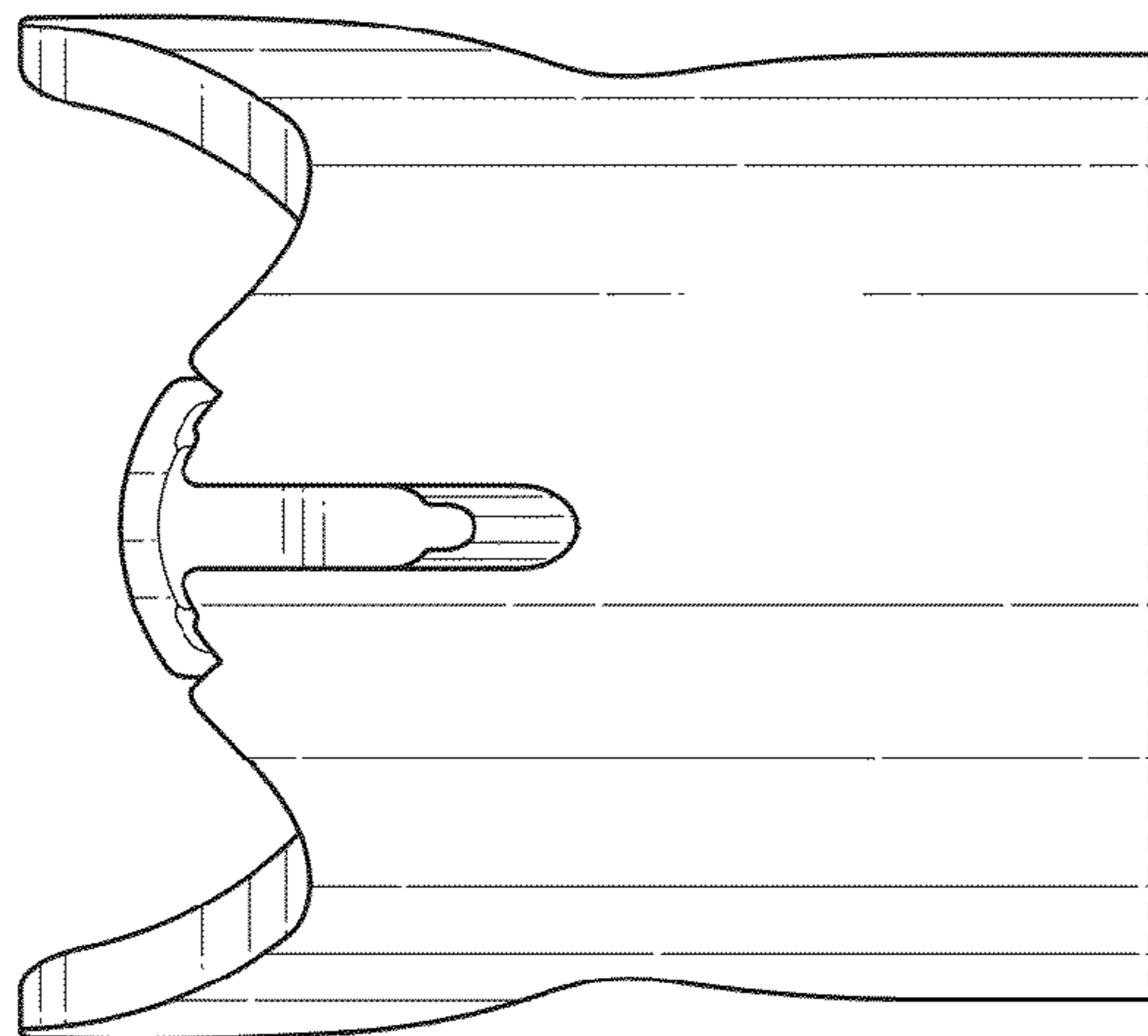

FIG. 10

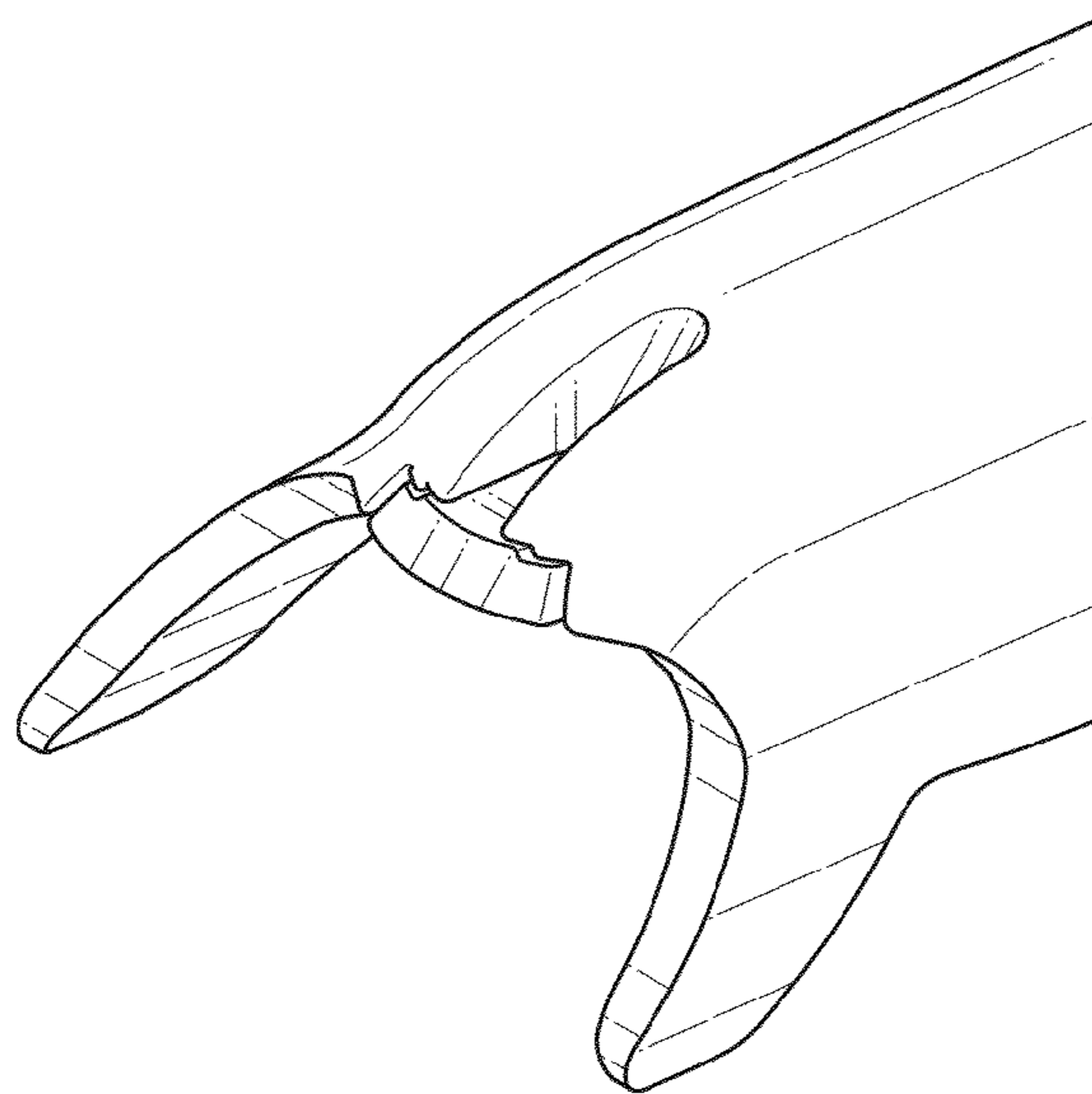

FIG. 11