



US00D710173S

(12) **United States Design Patent**  
**Frenken**

(10) **Patent No.:** **US D710,173 S**  
(45) **Date of Patent:** **\*\* Aug. 5, 2014**

(54) **HAND-HELD POWER TOOL**

6,453,719 B1 \* 9/2002 Heskey et al. .... 72/453.16  
6,619,101 B1 \* 9/2003 Faucher et al. .... 72/456  
6,666,064 B2 \* 12/2003 LeFavour et al. .... 72/453.15

(71) Applicant: **Gustav Klauke GmbH**, Remscheid  
(DE)

(Continued)

(72) Inventor: **Egbert Frenken**, Heinsberg (DE)

FOREIGN PATENT DOCUMENTS

(73) Assignee: **Gustav Klauke GmbH**, Remscheid  
(DE)

FR 2698026 5/1994

(\*\*) Term: **14 Years**

(21) Appl. No.: **29/460,885**

(22) Filed: **Jul. 16, 2013**

OTHER PUBLICATIONS

CN-58H: 6 Ton Remote Compression C-Head with Rubber  
Boot-.95" Jaw Opening. Apr. 13, 2013 [online], [retrieved on May 8,  
2013]. Retrieved from the Internet <URL: <http://www.huskiertools.com/products/cn-58h-6-ton-remote-compression-c-head-withrub-ber-boot-95-jaw-opening/>>.

(Continued)

**Related U.S. Application Data**

(62) Division of application No. 29/425,289, filed on Jun.  
21, 2012, now Pat. No. Des. 690,177.

*Primary Examiner* — Philip S Hyder  
*Assistant Examiner* — Darlington Ly

(30) **Foreign Application Priority Data**

Dec. 22, 2011 (EM) ..... 001307318

(74) *Attorney, Agent, or Firm* — Klintworth & Rozenblat IP  
LLC

(51) **LOC (10) Cl.** ..... **08-03**

(57) **CLAIM**

(52) **U.S. Cl.**  
USPC ..... **D8/68**; D8/61

The ornamental design for a hand-held power tool, as shown  
and described.

(58) **Field of Classification Search**  
USPC ..... D8/60, 61, 62, 67, 68, 69; 81/57, 57.11,  
81/57.14, 57.26, 429, 464, 469; 173/2,  
173/170, 176, 181

**DESCRIPTION**

See application file for complete search history.

FIG. 1 is a right side elevation view of a hand-held power tool;  
FIG. 2 is a top plan view of the hand-held power tool;  
FIG. 3 is a bottom plan view of the hand-held power tool;  
FIG. 4 is a rear elevation view of the hand-held power tool;  
FIG. 5 is a front elevation view of the hand-held power tool;  
FIG. 6 is a left side elevation view of a hand-held power tool;  
and,  
FIG. 7 is a perspective view of the hand-held power tool.

(56) **References Cited**

U.S. PATENT DOCUMENTS

D309,563 S \* 7/1990 Astle ..... D8/60  
D329,793 S \* 9/1992 Fukuda ..... D8/60  
5,381,686 A \* 1/1995 Thorup ..... 72/453.06  
D378,340 S \* 3/1997 Harter ..... D8/60

**1 Claim, 4 Drawing Sheets**

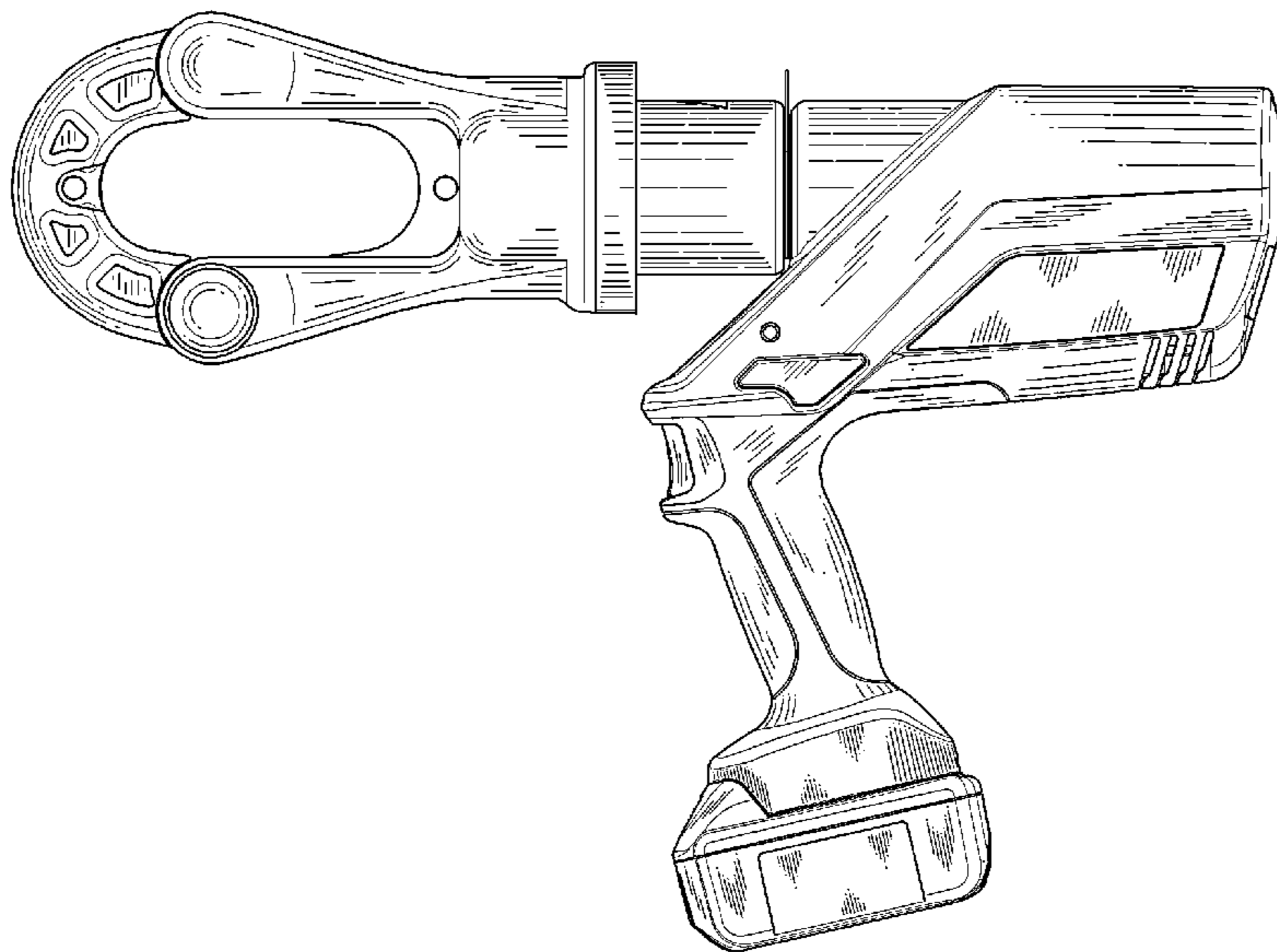

(56)

**References Cited**

U.S. PATENT DOCUMENTS

6,718,870	B1 *	4/2004	Frenken	100/266
D531,867	S *	11/2006	Payne et al.	D8/61
D673,829	S *	1/2013	Takeshima et al.	D8/61
2005/0005672	A1 *	1/2005	Sneath	72/453.16
2009/0313820	A1 *	12/2009	Roman et al.	29/863

OTHER PUBLICATIONS

Battery Powered Hydraulic Tools. [www.crimping-tool.com](http://www.crimping-tool.com). Oct. 4, 2012 [online], [retrieved on May 8, 2013]. Retrieved from the

Internet <URL: <http://www.crimping-tool.com/Battery-Powered-Hydraulic-Crimping-Tools.htm>>.

Green Lee A Tectron Company—Crimp Tool, Dieless Remote FT. Apr. 9, 2012 [online], [retrieved on May 8, 2013]. Retrieved from the Internet <URL: [http://www.greenlee.com/products/CRIM\\_P-TOOL%2540cDI\\_ELESS%2540dREMOTEF.html?product\\_id=17980](http://www.greenlee.com/products/CRIM_P-TOOL%2540cDI_ELESS%2540dREMOTEF.html?product_id=17980)>.

Thomas & Betts. Power-Assisted Compression Tools: #8 to 1500 or 2000MCM. Apr. 9, 2012 [online], [retrieved on May 8, 2013]. Retrieved from the Internet <URL: <http://www.specialized.net/Specialized//Assets/ProductSpecifications//272X016.PDF>>.

\* cited by examiner

***Fig. 3***

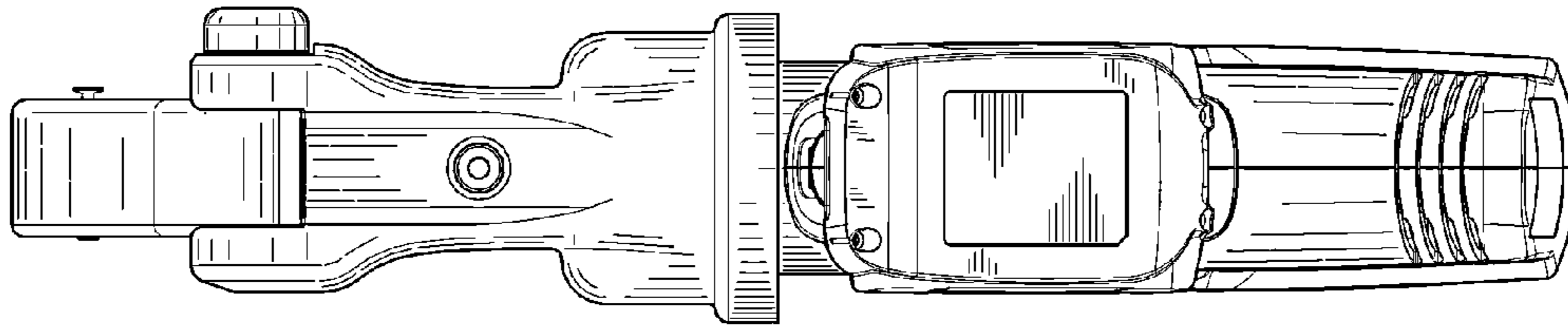

***Fig. 1***

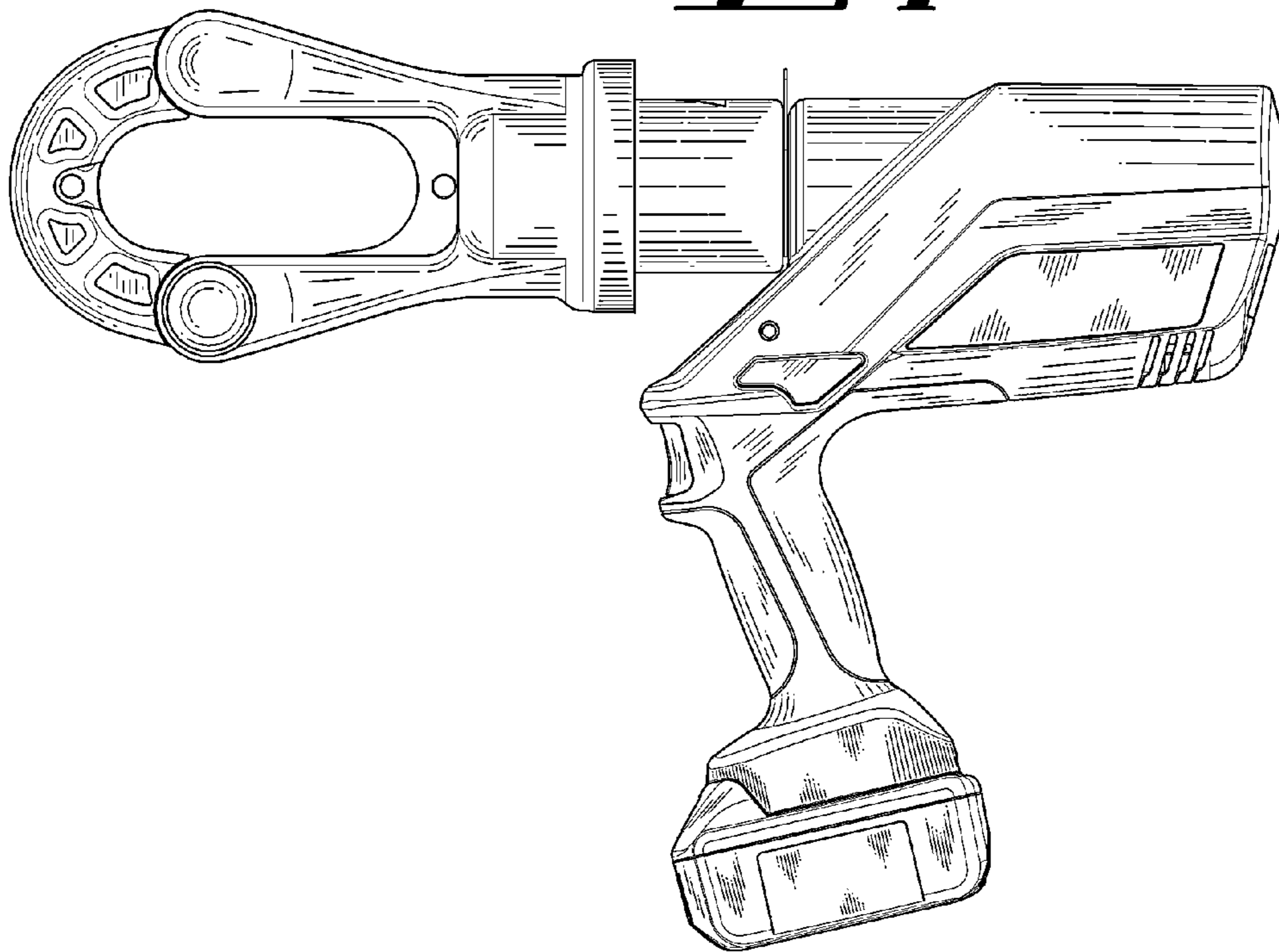

***Fig. 2***

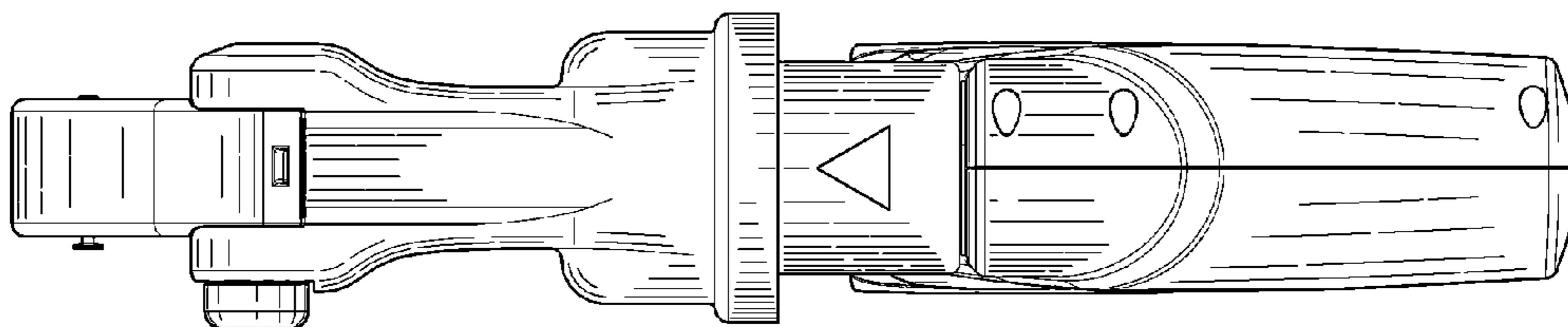

***Fig. 4***

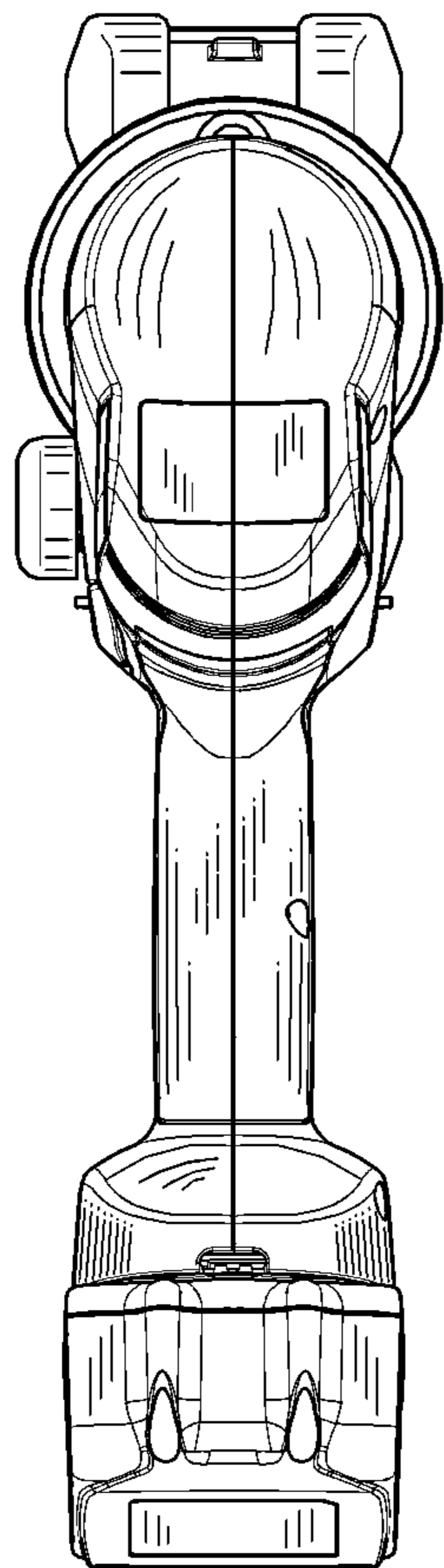

***Fig. 5***

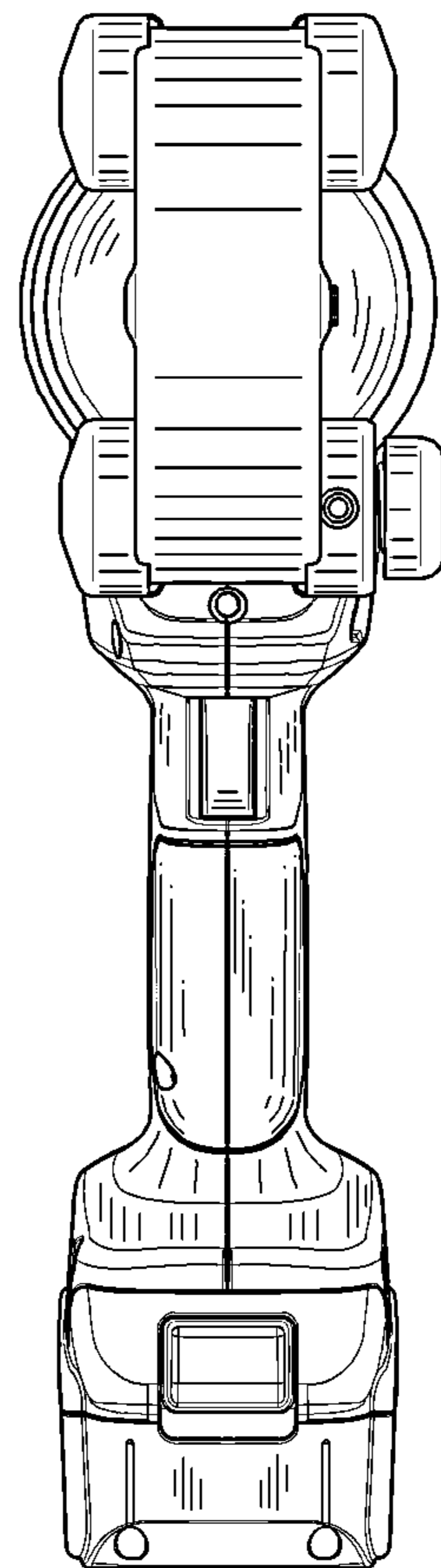

***Fig. 6***

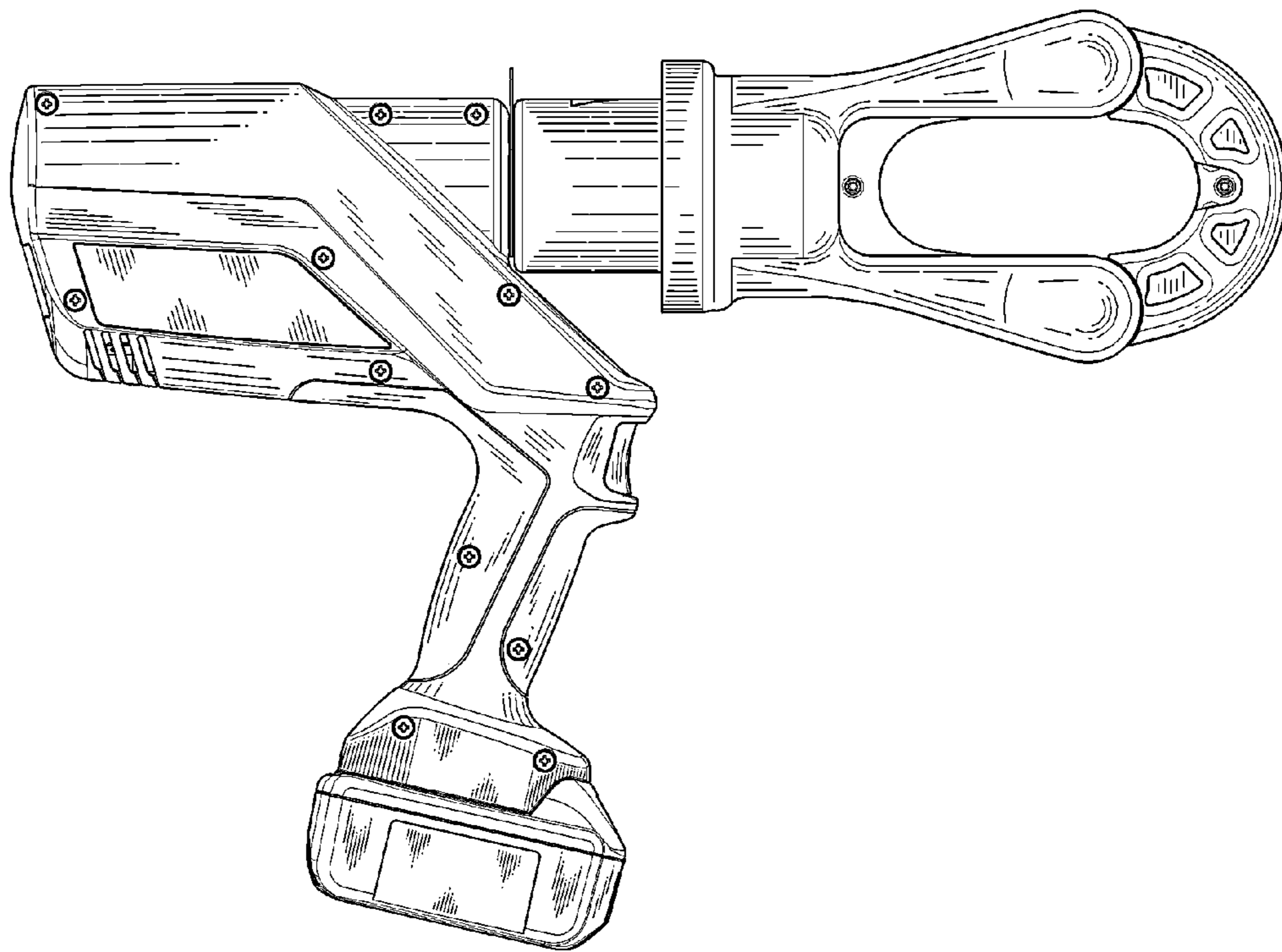



***Fig. 7***

