



US00D709809S

(12) **United States Design Patent**
Clark

(10) **Patent No.:** **US D709,809 S**

(45) **Date of Patent:** **** Jul. 29, 2014**

(54) **FRONT COWLING OF A MULTI-PURPOSE VEHICLE**

(71) Applicant: **Denver Global Products, Inc.,**
Lincolnton, NC (US)

(72) Inventor: **Travis Clark,** Cornelius, NC (US)

(73) Assignee: **Denver Global Products, Inc.,**
Lincolnton, NC (US)

(**) Term: **14 Years**

(21) Appl. No.: **29/456,190**

(22) Filed: **May 29, 2013**

(51) **LOC (10) Cl.** **12-16**

(52) **U.S. Cl.**
USPC **D12/173**

(58) **Field of Classification Search**
USPC D12/14, 1, 87, 86, 433, 15, 16, 107, 82,
D12/88, 89, 90, 91, 92, 93, 173, 3, 110,
D12/114; D21/803, 424, 433, 434; 180/233,
180/908; 208/DIG. 5, 183, 184, 185, 186,
208/28, 37.7; D15/31, 15, 17

See application file for complete search history.

(56) **References Cited**

U.S. PATENT DOCUMENTS

D426,270	S	*	6/2000	Rubau	D21/433
D430,619	S	*	9/2000	Wang et al.	D21/433
D502,132	S	*	2/2005	Bonner et al.	D12/196
D532,022	S	*	11/2006	Kuwae	D15/31
D625,668	S	*	10/2010	Chang et al.	D12/110
2013/0069337	A1	*	3/2013	Person et al.	280/124.156

* cited by examiner

Primary Examiner — T. Chase Nelson

Assistant Examiner — Ania Aman

(74) *Attorney, Agent, or Firm* — Additon, Higgins,
Pendleton & Ashe, P.A.

(57) **CLAIM**

The ornamental design for a front cowling of a multi-purpose vehicle, as shown and described.

DESCRIPTION

FIG. 1 is a perspective view of a front cowling of a multi-purpose vehicle showing the new design; FIG. 2 is a front elevation view thereof; FIG. 3 is a rear elevation view thereof; FIG. 4 is a left side view thereof; FIG. 5 is a right side view thereof; FIG. 6 is a top plan view thereof; and, FIG. 7 is bottom plan view thereof. The broken lines shown in the drawings are for the purpose of illustrating environmental structure that forms no part of the claimed design.

1 Claim, 7 Drawing Sheets

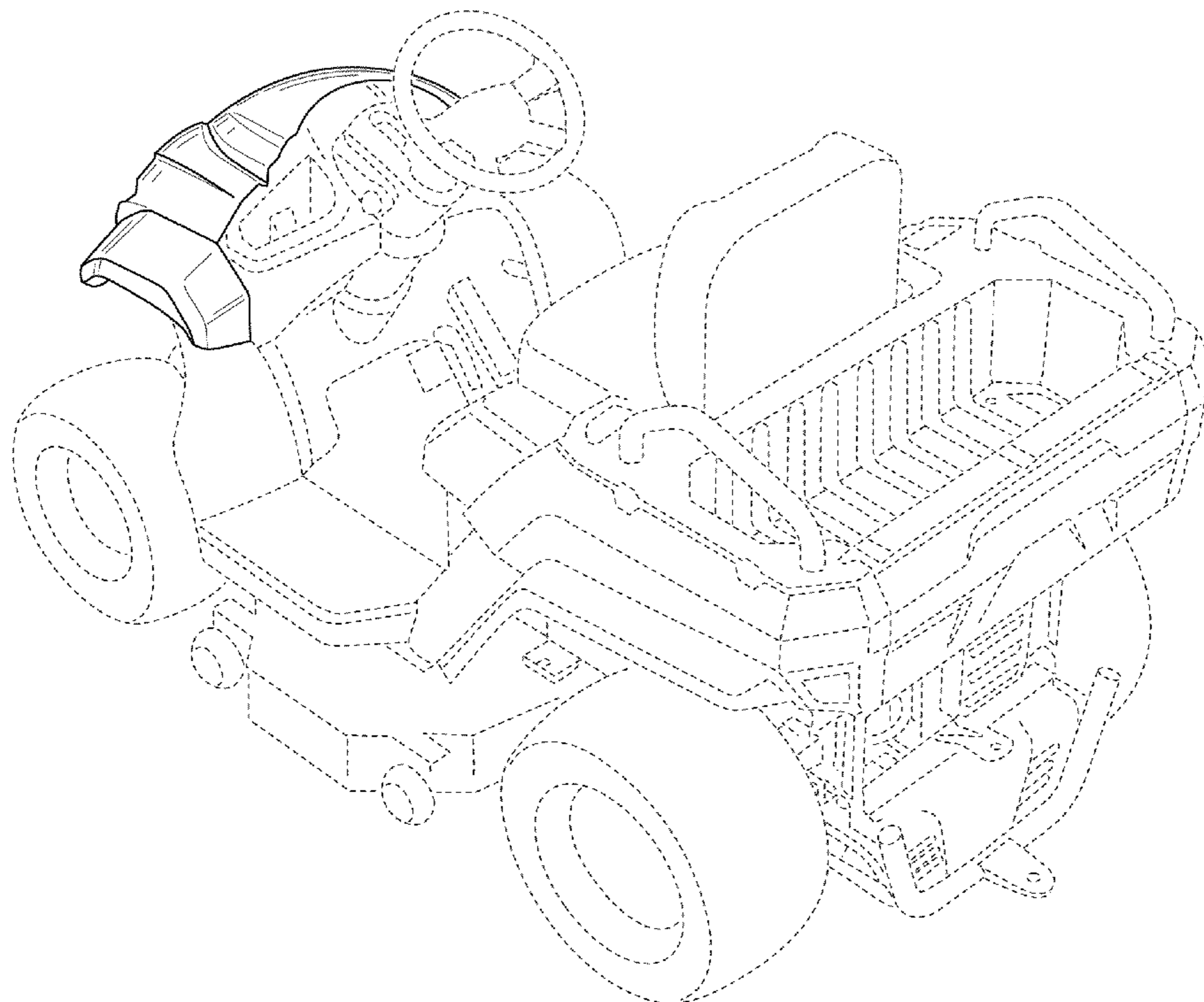

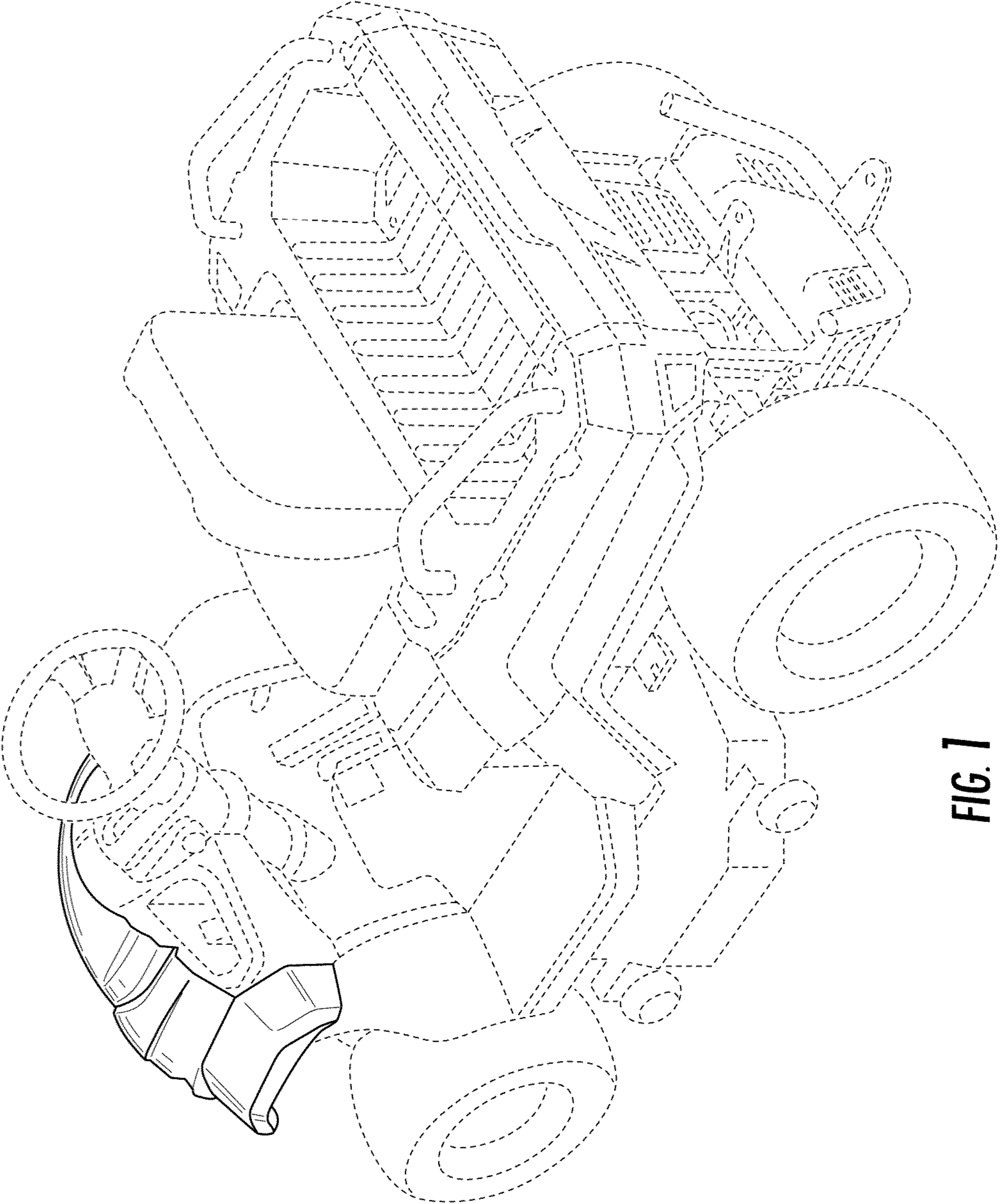

FIG. 1

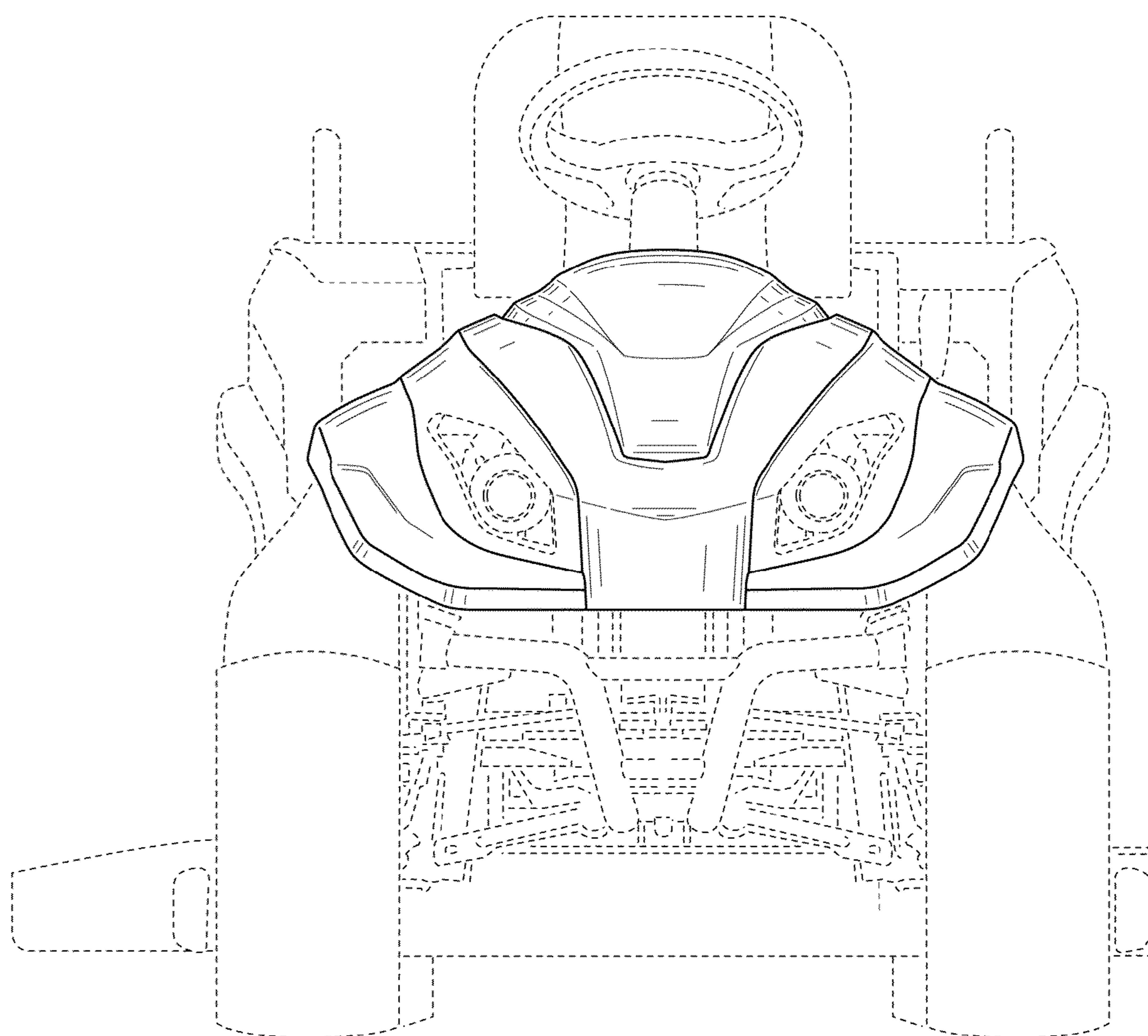

FIG. 2

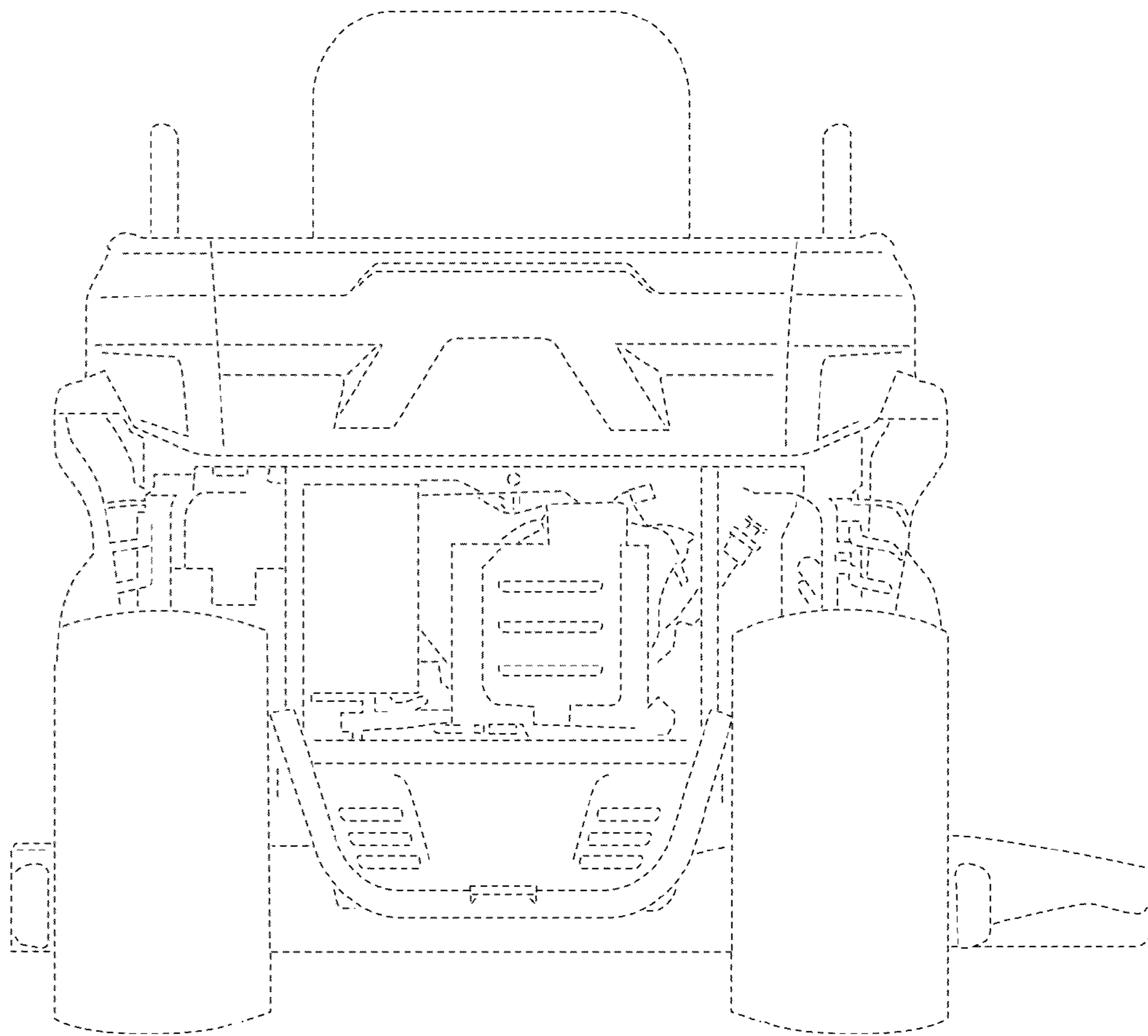

FIG. 3

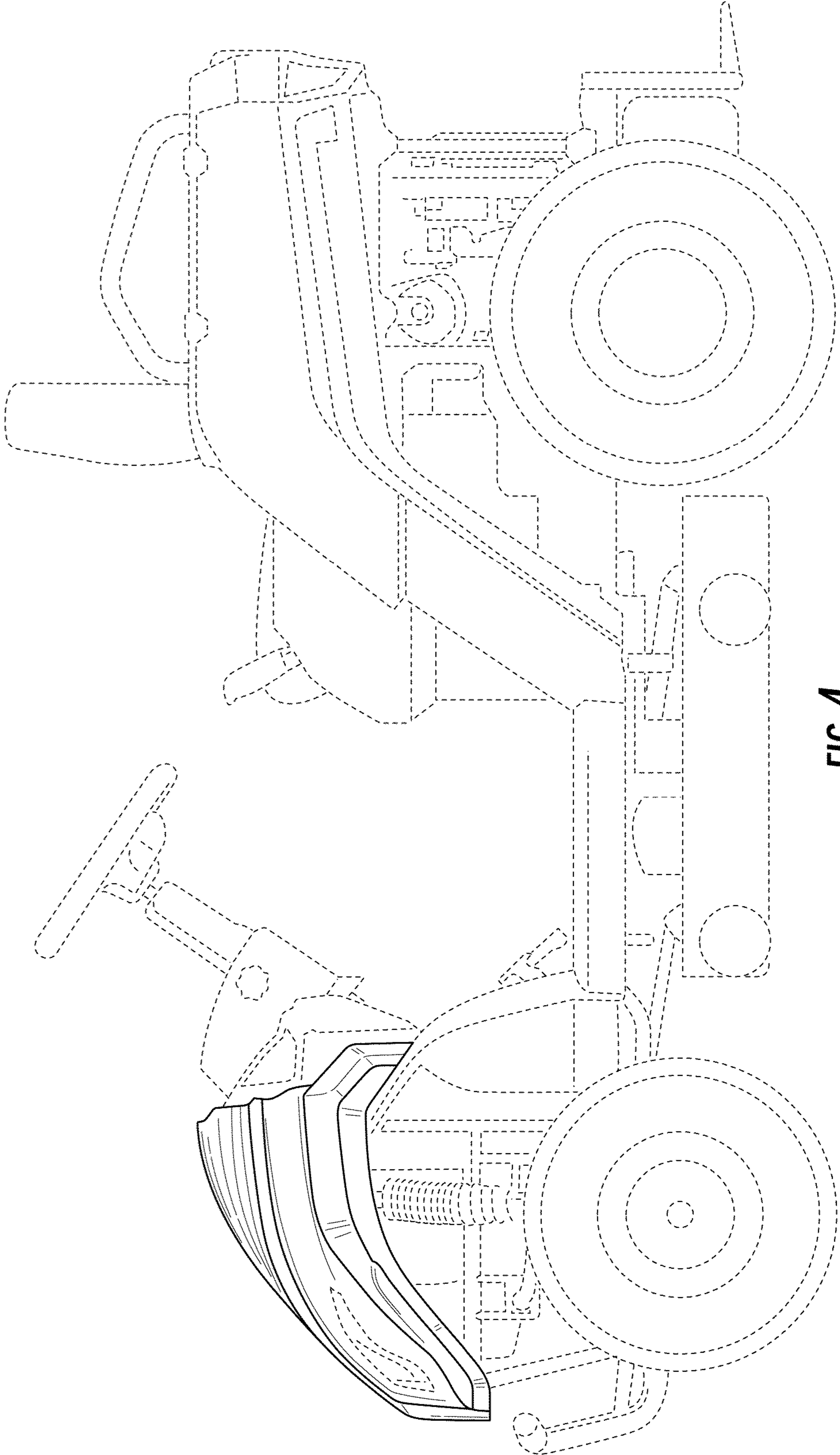

FIG. 4

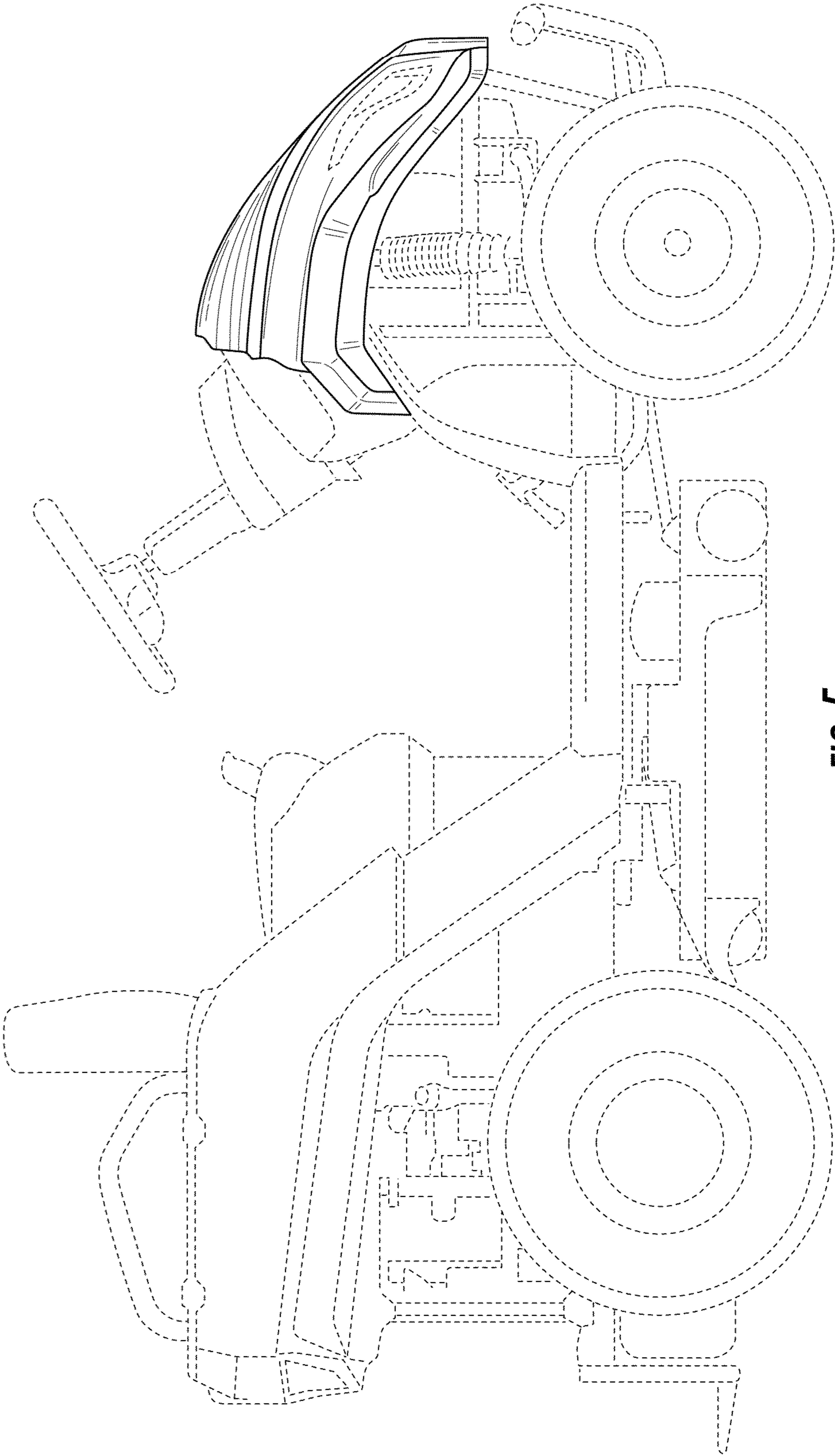

FIG. 5

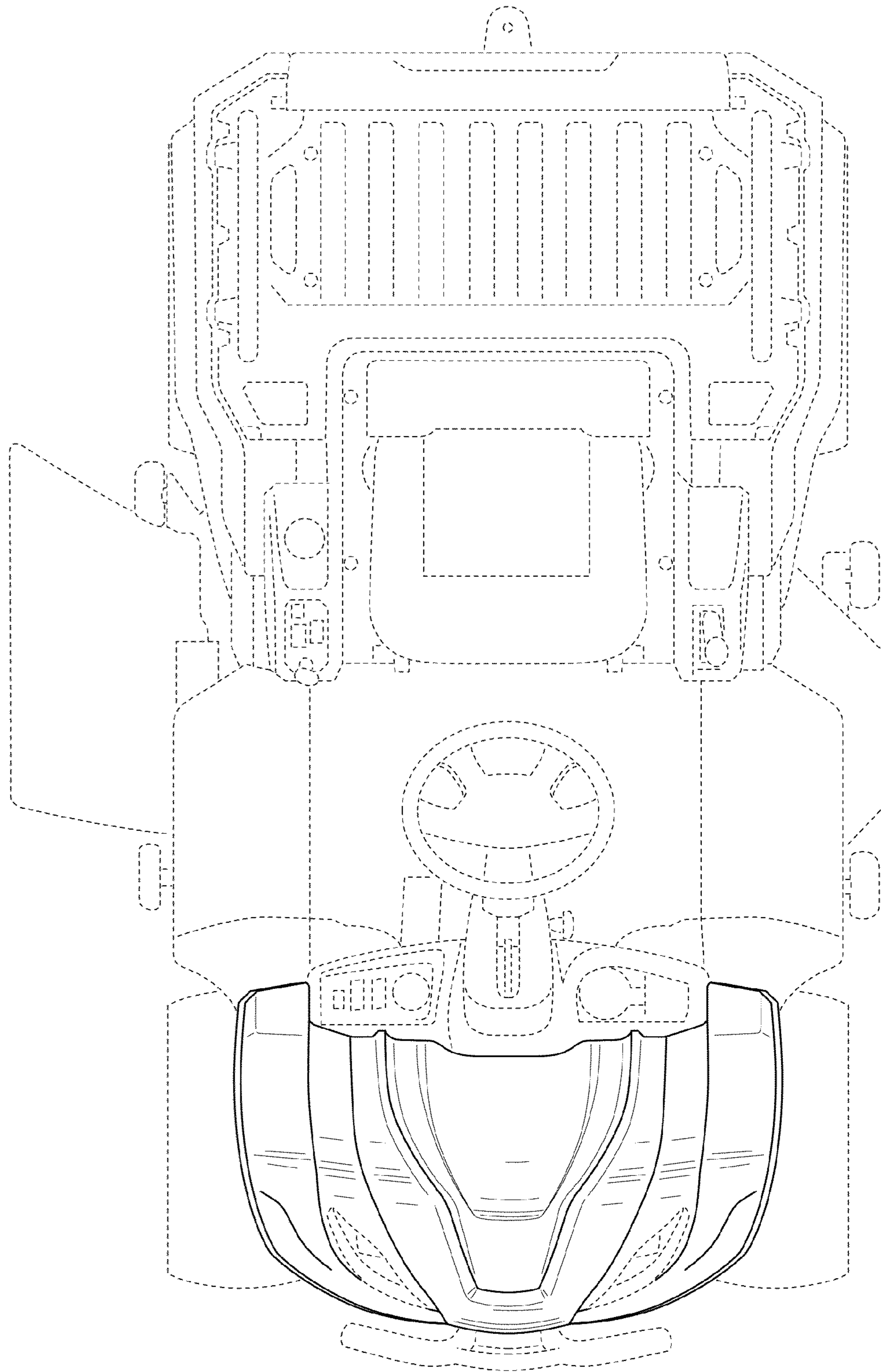

FIG. 6

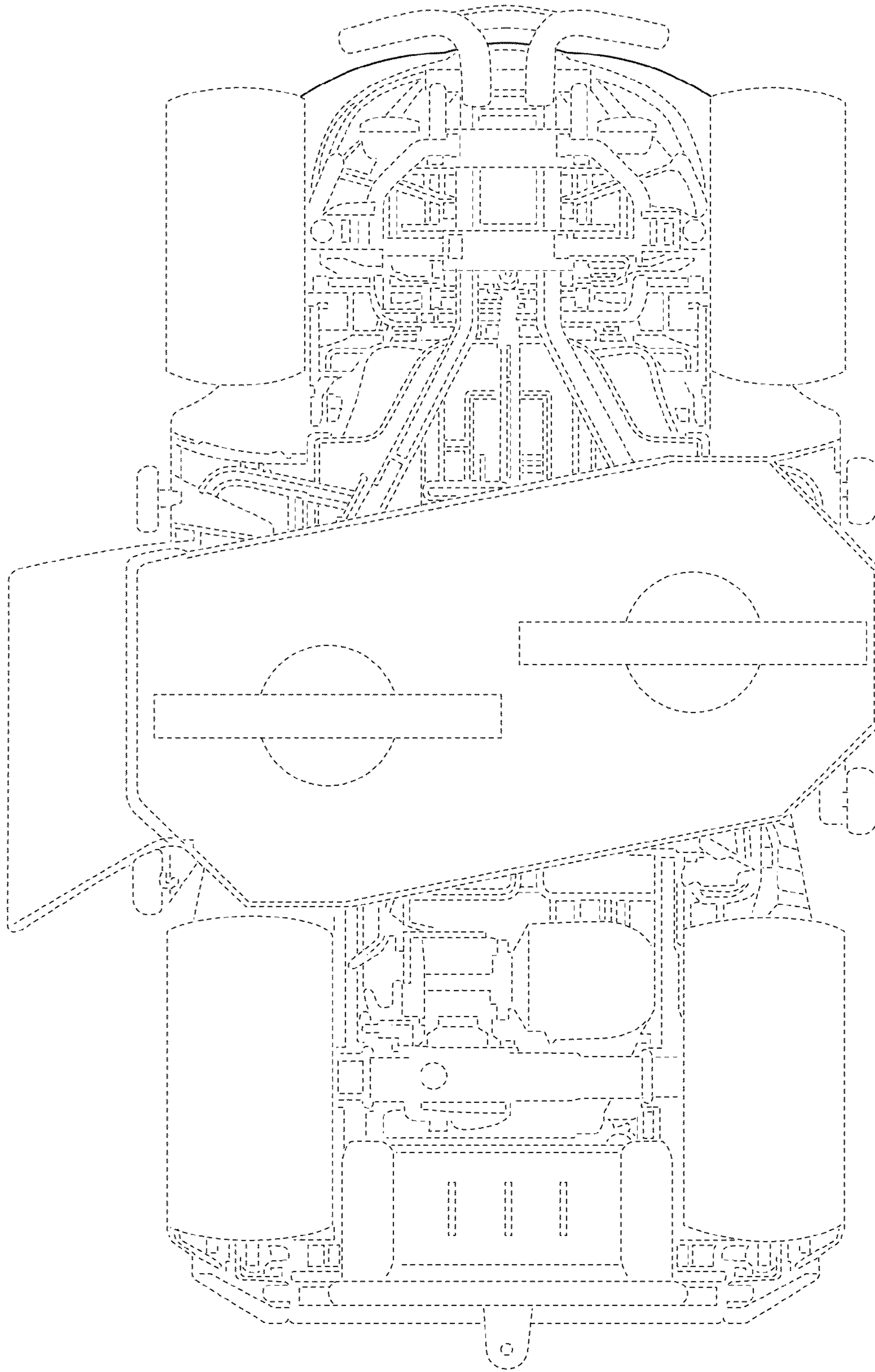

FIG. 7