



US00D709463S

(12) **United States Design Patent**
Junko et al.

(10) **Patent No.:** **US D709,463 S**
(45) **Date of Patent:** **** Jul. 22, 2014**

(54) **SQUARE SWITCH**

(75) Inventors: **Theodore Junko**, Manlius, NY (US);
Taesuk Yang, Wallingford, CT (US);
Phillip Prestigomo, Simsbury, CT (US);
Gerald Savicki, Jr., Canastota, NY
(US); **Pierre-Yves Panis**, Isle (FR)

(73) Assignee: **Pass & Seymour, Inc.**, Syracuse, NY
(US)

(**) Term: **14 Years**

(21) Appl. No.: **29/414,397**

(22) Filed: **Feb. 28, 2012**

(51) **LOC (10) Cl.** **13-03**

(52) **U.S. Cl.**
USPC **D13/169**

(58) **Field of Classification Search**
USPC D13/162, 169, 174; 307/139, 157;
200/5 R, 5 A, 302.2, 520, 530, 293, 296,
200/308, 310, 314, 315, 329, 339, 341;
315/209 R, 224, 246, 291, 294, 295
See application file for complete search history.

D539,236 S 3/2007 Mayo et al.
D539,237 S 3/2007 Mayo et al.
D539,757 S 4/2007 Mayo et al.
D540,266 S 4/2007 Mayo et al.
D540,267 S 4/2007 Larson et al.
D540,748 S 4/2007 Larson et al.
D541,221 S 4/2007 Spira
D541,222 S 4/2007 Mayo et al.
D541,223 S 4/2007 Mayo et al.
D541,224 S 4/2007 Mayo et al.
D541,755 S 5/2007 Spira
D542,226 S 5/2007 Spira
D542,227 S 5/2007 Larson et al.
D542,229 S 5/2007 Larson et al.
D542,231 S 5/2007 Mayo et al.
D542,737 S 5/2007 Spira
D543,510 S 5/2007 Larson et al.
D544,450 S 6/2007 Mierta et al.
D545,770 S 7/2007 Mayo et al.
D545,771 S 7/2007 Jacoby et al.
D546,293 S 7/2007 Mayo et al.
D546,775 S 7/2007 Mayo et al.
D546,776 S 7/2007 Mierta et al.
D546,777 S 7/2007 Mierta et al.
D546,778 S 7/2007 Mierta et al.
D546,779 S 7/2007 Mierta et al.
D547,273 S 7/2007 Mierta et al.
D547,274 S 7/2007 Mierta et al.
D547,731 S 7/2007 Larson et al.
D547,732 S 7/2007 Kumar
D548,194 S 8/2007 Spira
D551,176 S 9/2007 Hollner
D551,177 S 9/2007 Larson et al.
D551,630 S 9/2007 Larson et al.
D557,662 S 12/2007 Spira
D557,664 S 12/2007 Hewsen et al.
D557,665 S 12/2007 Hewsen et al.
D559,710 S 1/2008 Jacoby et al.
D560,619 S 1/2008 Hewsen et al.
D567,767 S 4/2008 Hewsen et al.
D569,351 S 5/2008 Hewsen et al.
D571,312 S 6/2008 Hewsen et al.
D572,664 S 7/2008 Hollner et al.
D572,665 S 7/2008 Hollner et al.
D573,546 S 7/2008 Hollner
D573,956 S 7/2008 Hollner et al.
D574,333 S 8/2008 Hewson et al.
D576,566 S * 9/2008 Wu et al. D13/169
D576,958 S 9/2008 Hollner
D580,374 S 11/2008 Hewson et al.
D580,881 S 11/2008 Hollner et al.
D580,882 S 11/2008 Hollner et al.
D583,335 S * 12/2008 Ni D13/169

(56) **References Cited**

U.S. PATENT DOCUMENTS

3,651,296 A * 3/1972 Yarbrough 200/315
4,808,778 A * 2/1989 Fujiyoshi 200/339
5,036,168 A * 7/1991 Kikuchi et al. 200/5 R
D360,876 S * 8/1995 Hughes D13/177
5,934,451 A * 8/1999 Yu et al. 200/315
D440,946 S * 4/2001 Yu D13/169
D499,703 S * 12/2004 Barone D13/174
6,891,117 B1 * 5/2005 Gouhl et al. 200/339
D509,805 S 9/2005 Spira
D510,073 S 9/2005 Jacoby et al.
D510,074 S 9/2005 Larson et al.
D518,446 S * 4/2006 Hedderich et al. D13/162
7,026,564 B1 * 4/2006 Savicki et al. 200/339
D523,824 S * 6/2006 Lombardi et al. D13/169
D533,844 S 12/2006 Larson et al.
D534,875 S * 1/2007 Wu D13/169
D538,755 S 3/2007 Mayo et al.
D539,233 S 3/2007 Mayo et al.

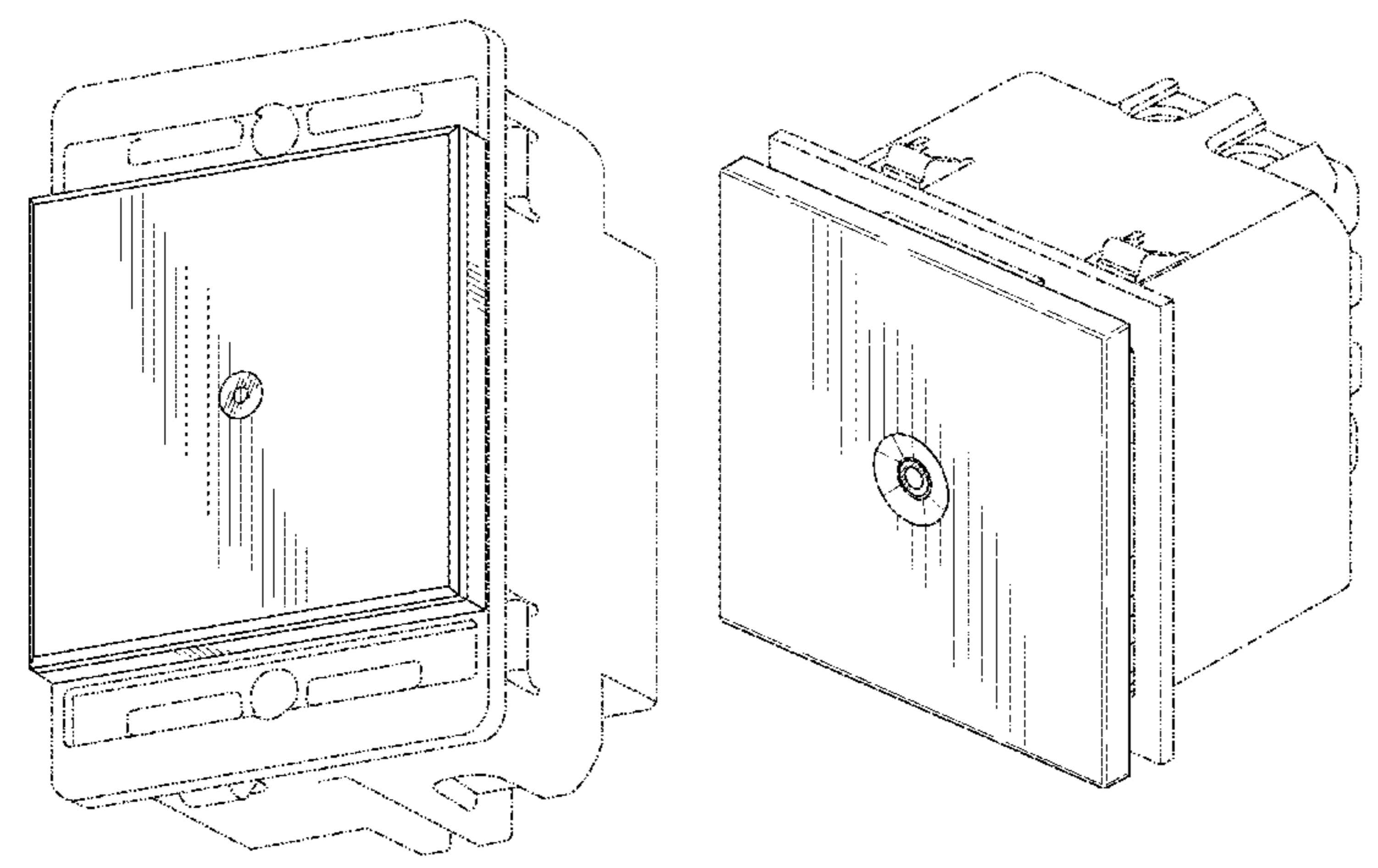

D585,840 S	2/2009	Hollner	
D585,841 S	2/2009	Hollner	
D585,883 S	2/2009	Kaneko	
D585,884 S	2/2009	Pletikosa	
D586,760 S	2/2009	Hollner et al.	
D586,762 S *	2/2009	Nichols et al.	D13/171
D588,070 S	3/2009	Hollner et al.	
D588,071 S	3/2009	Hollner et al.	
D588,072 S	3/2009	Hollner et al.	
D588,073 S	3/2009	Hollner	
D588,074 S	3/2009	Hollner	
D588,075 S	3/2009	Hollner	
D595,663 S	7/2009	Hollner	
D595,665 S	7/2009	Hollner	
D609,650 S *	2/2010	Chou et al.	D13/169
7,667,155 B1 *	2/2010	Ni et al.	200/556
D614,589 S	4/2010	Altonen et al.	
D619,972 S	7/2010	Felegy et al.	
D624,880 S	10/2010	Felegy et al.	
D649,122 S *	11/2011	Jacoby et al.	D13/162
D649,123 S *	11/2011	Jacoby et al.	D13/164
D651,182 S *	12/2011	Alderson et al.	D13/169
8,459,812 B2 *	6/2013	Wu et al.	362/23.01
2002/0056628 A1 *	5/2002	Capella	200/314
2006/0065510 A1 *	3/2006	Kiko et al.	200/1 R
2007/0193863 A1 *	8/2007	Wu	200/61.72
2008/0078665 A1 *	4/2008	Egea Soler	200/315
2009/0189542 A1 *	7/2009	Wu et al.	315/294
2013/0277191 A1 *	10/2013	Trolese et al.	200/501

* cited by examiner

Primary Examiner — Selina Sikder

(74) *Attorney, Agent, or Firm* — Daniel P. Malley; Bond Schoeneck & King, PLLC

(57) **CLAIM**

The ornamental design for a square switch, as shown and described.

DESCRIPTION

FIG. 1 is a full isometric view of a square switch having an annular light transmissive region or annular marking, the switch being shown as it comes from the factory on its mounting plate, the plate and integral hardware behind it being shown in environmental lines;

FIG. 2 is the same isometric view of the switch depicted in FIG. 1 as seen extending through a central square shaped opening of a wall plate cover, the wall plate cover being shown in environmental lines;

FIG. 3 is a front view of the switch depicted in FIG. 1 (Note: no back side plan view is shown because nothing is claimed about that side of the invention);

FIG. 4 is a left side elevation view of the switch depicted in FIG. 1 (Note: a right side elevation view is omitted because it is the mirror image of the left side elevation view);

FIG. 5 is a top view of the switch depicted in FIG. 1 (Note: a bottom side view is omitted because it is the mirror image of the top side elevation view);

FIG. 6 is another alternate embodiment of the square switch depicted in FIGS. 1-5, the switch including a center light transmissive region or marking surrounded by an annular light transmissive region or marking;

FIG. 7 is a full isometric view of a square switch having an annular light transmissive region or annular marking, the switch being shown as it comes from the factory on its mounting plate, the plate and integral hardware behind it being shown in environmental lines;

FIG. 8 is the same isometric view of the switch depicted in FIG. 7 as seen extending through a central square shaped opening of a wall plate cover, the wall plate cover being shown in environmental lines;

FIG. 9 is a front elevation view of the switch depicted in FIG. 7 (Note: no back elevation view is shown because nothing is claimed about that side of the invention);

FIG. 10 is a left side elevation view of the switch depicted in FIG. 7 (Note: a right side elevation view is omitted because it is the mirror image of the left side elevation view);

FIG. 11 is a top plan view of the switch depicted in FIG. 7 (Note: a bottom plan view is omitted because it is the mirror image of the top plan elevation view);

FIG. 12 is another alternate embodiment of the square switch depicted in FIGS. 7-11, the switch including a center light transmissive region or marking surrounded by an annular light transmissive region or marking;

FIG. 13 is a full isometric view of a square switch having an annular light transmissive region or annular marking within a concave annular region, the switch being shown as it comes from the factory on its mounting plate, the plate and integral hardware behind it being shown in environmental lines;

FIG. 14 is the same isometric view of the switch depicted in FIG. 13 as seen extending through a central square shaped opening of a wall plate cover, the wall plate cover being shown in environmental lines;

FIG. 15 is a front elevation view of the switch depicted in FIG. 13 (Note: no back elevation view is shown because nothing is claimed about that side of the invention);

FIG. 16 is a left side elevation view of the switch depicted in FIG. 13 (Note: the right side elevation view is the mirror image of the left side elevation view);

FIG. 17 is a top plan view of the switch depicted in FIG. 13 (Note: the bottom plan view is the mirror image of the top plan view); and,

FIG. 18 is another alternate embodiment of the square switch depicted in FIGS. 13-17, the switch including a center light transmissive region or marking surrounded by an annular light transmissive region or marking disposed with a concave annular region.

The broken line showing of the environment is for illustrative purposes only and forms no part of the claimed design.

1 Claim, 12 Drawing Sheets

Fig. 1

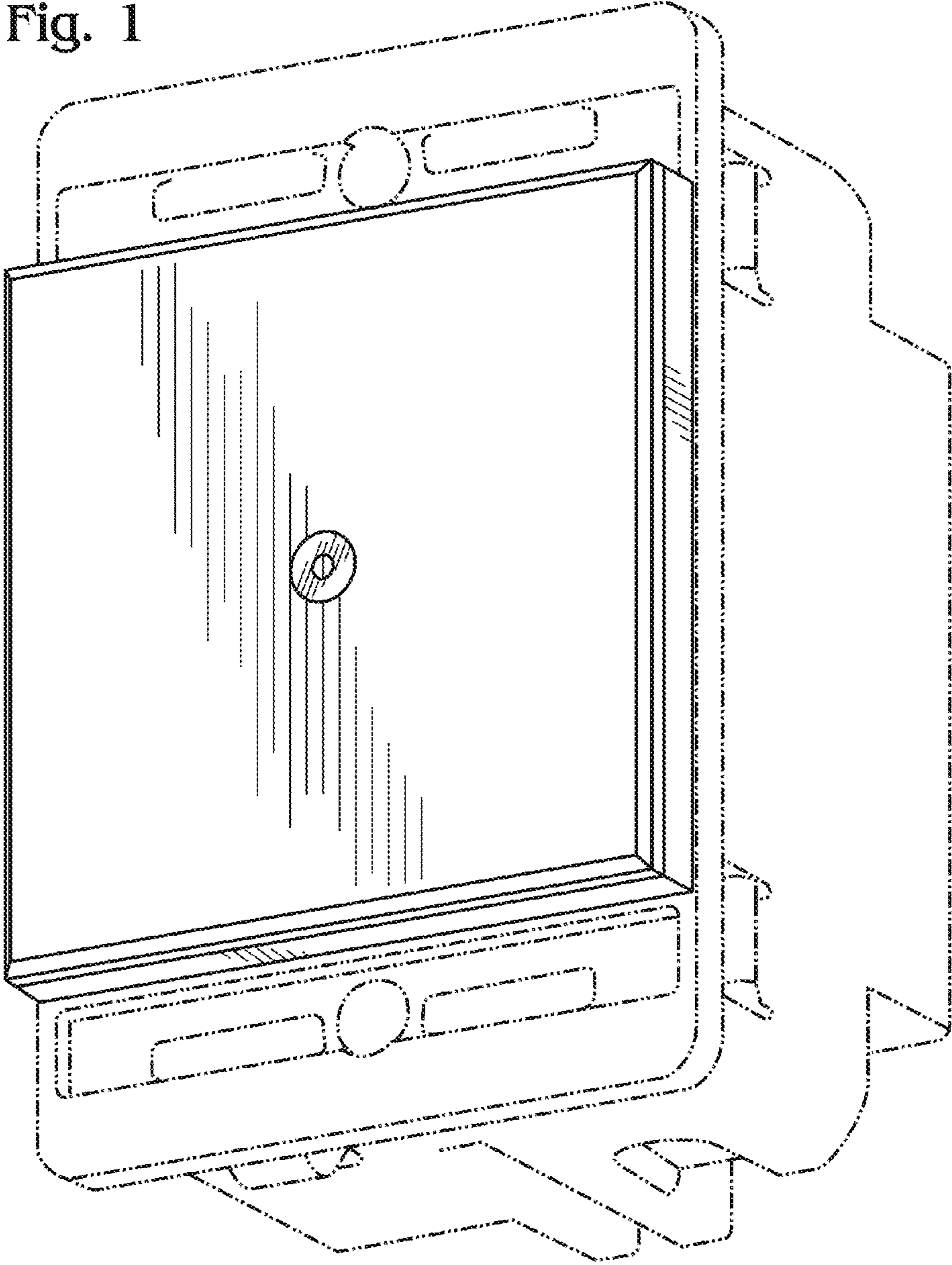

Fig. 2

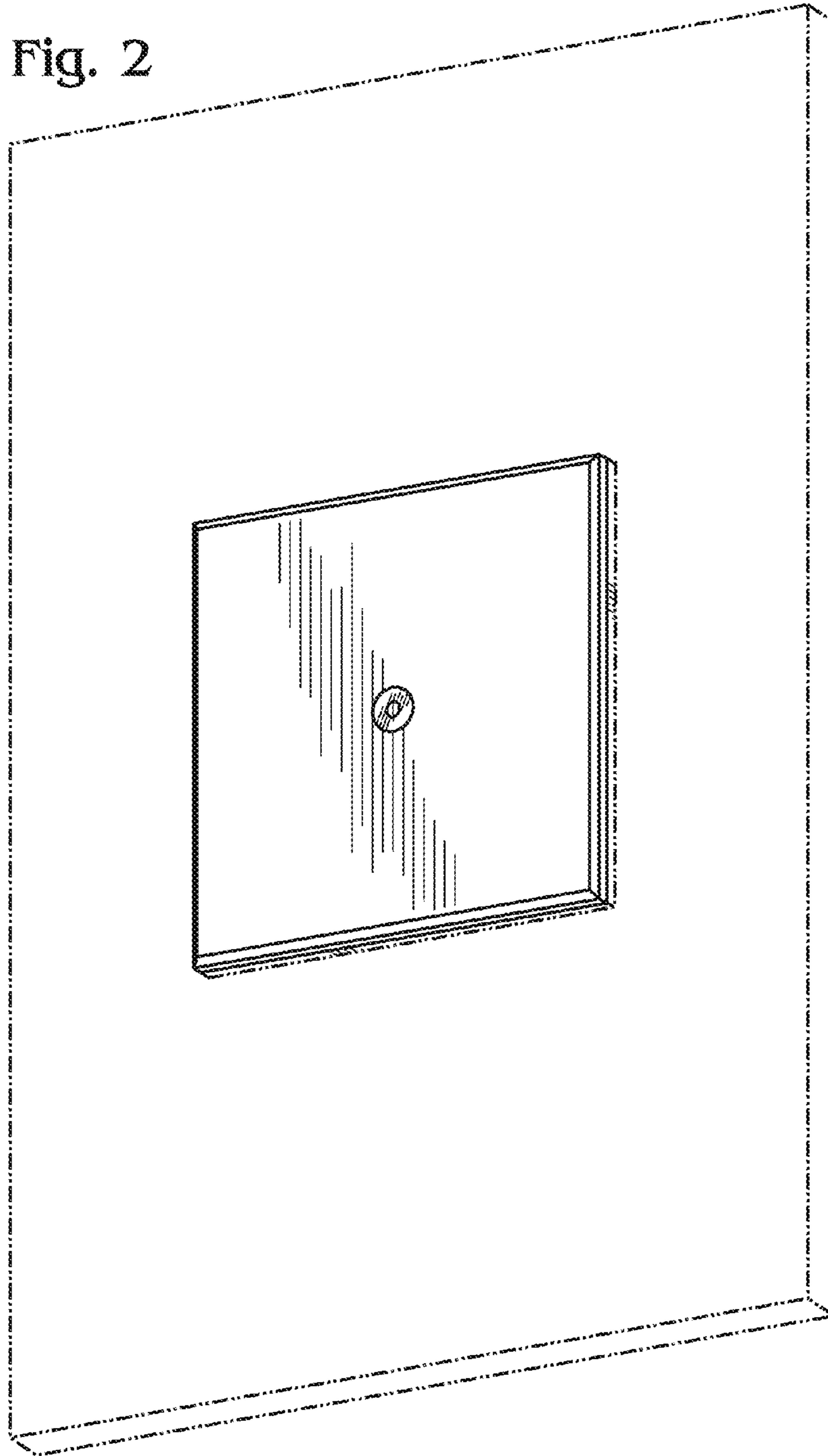

Fig. 3

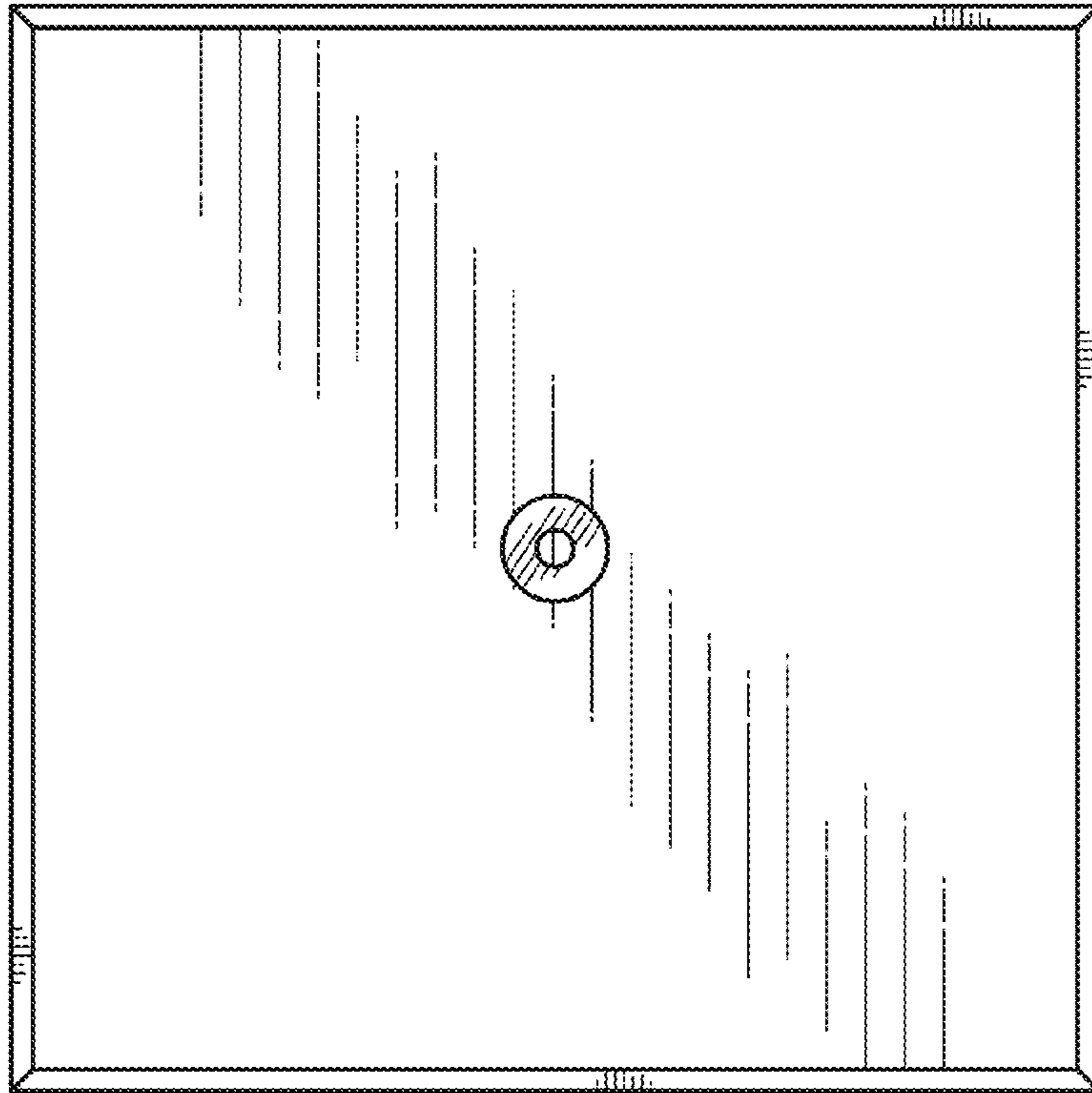

Fig. 4

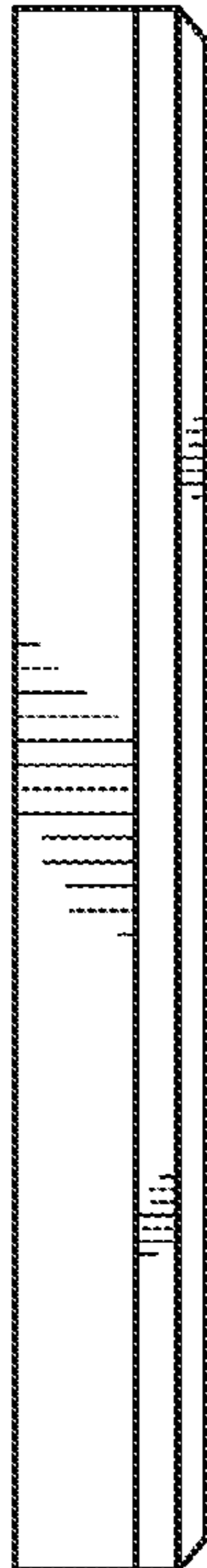

Fig. 5

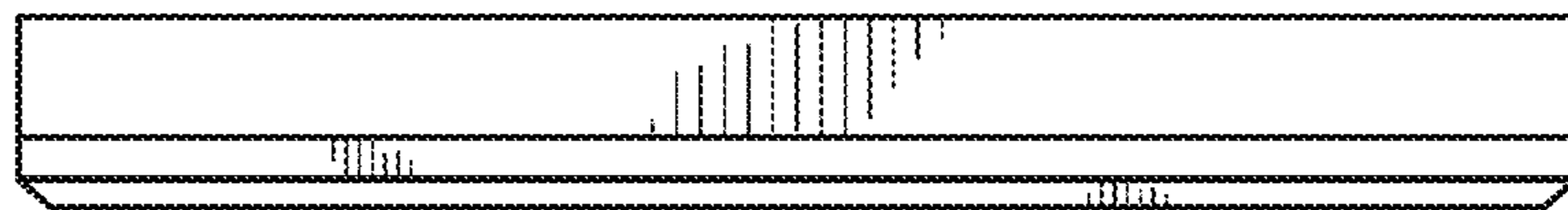

Fig. 6

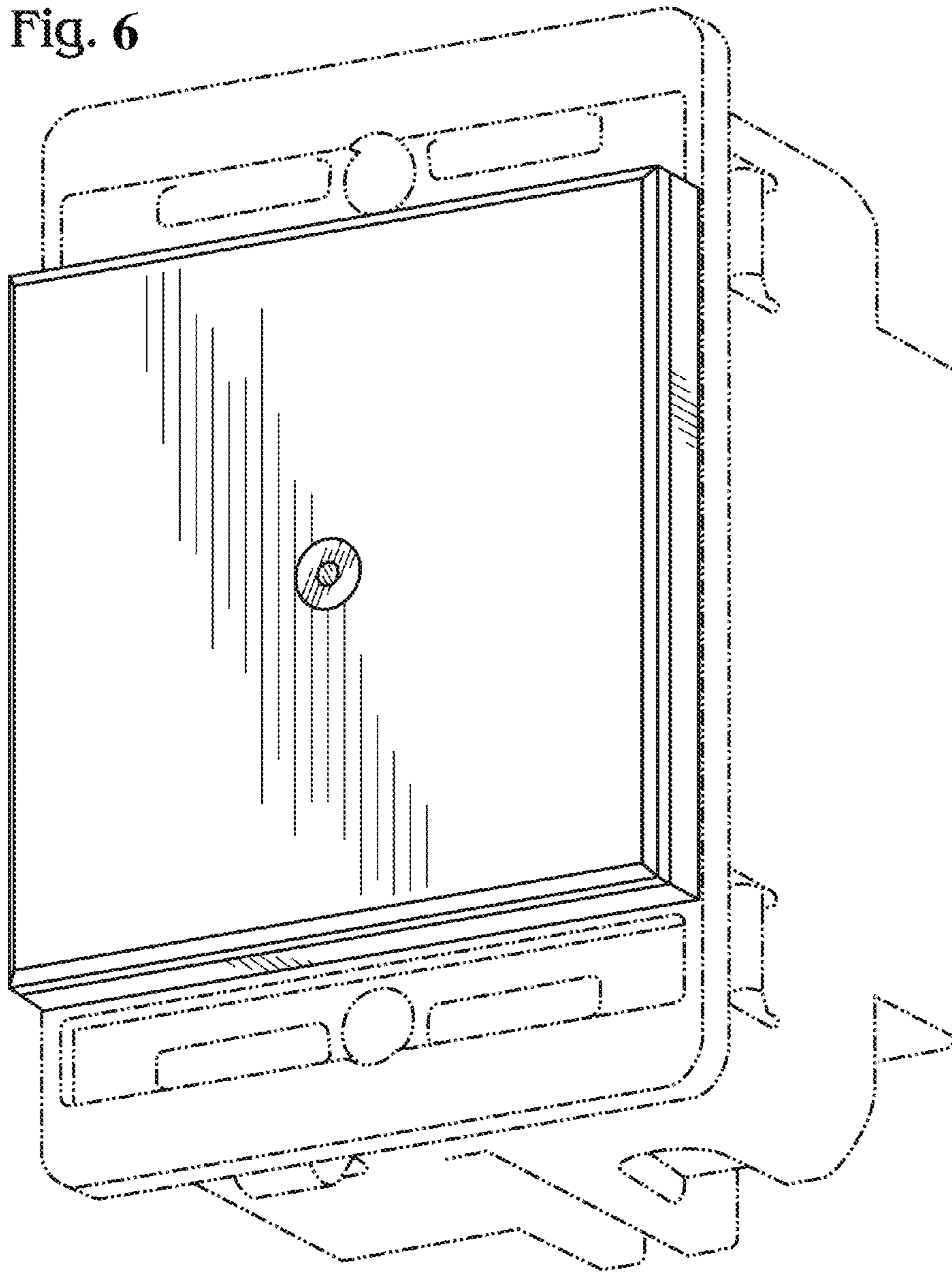

Fig. 7

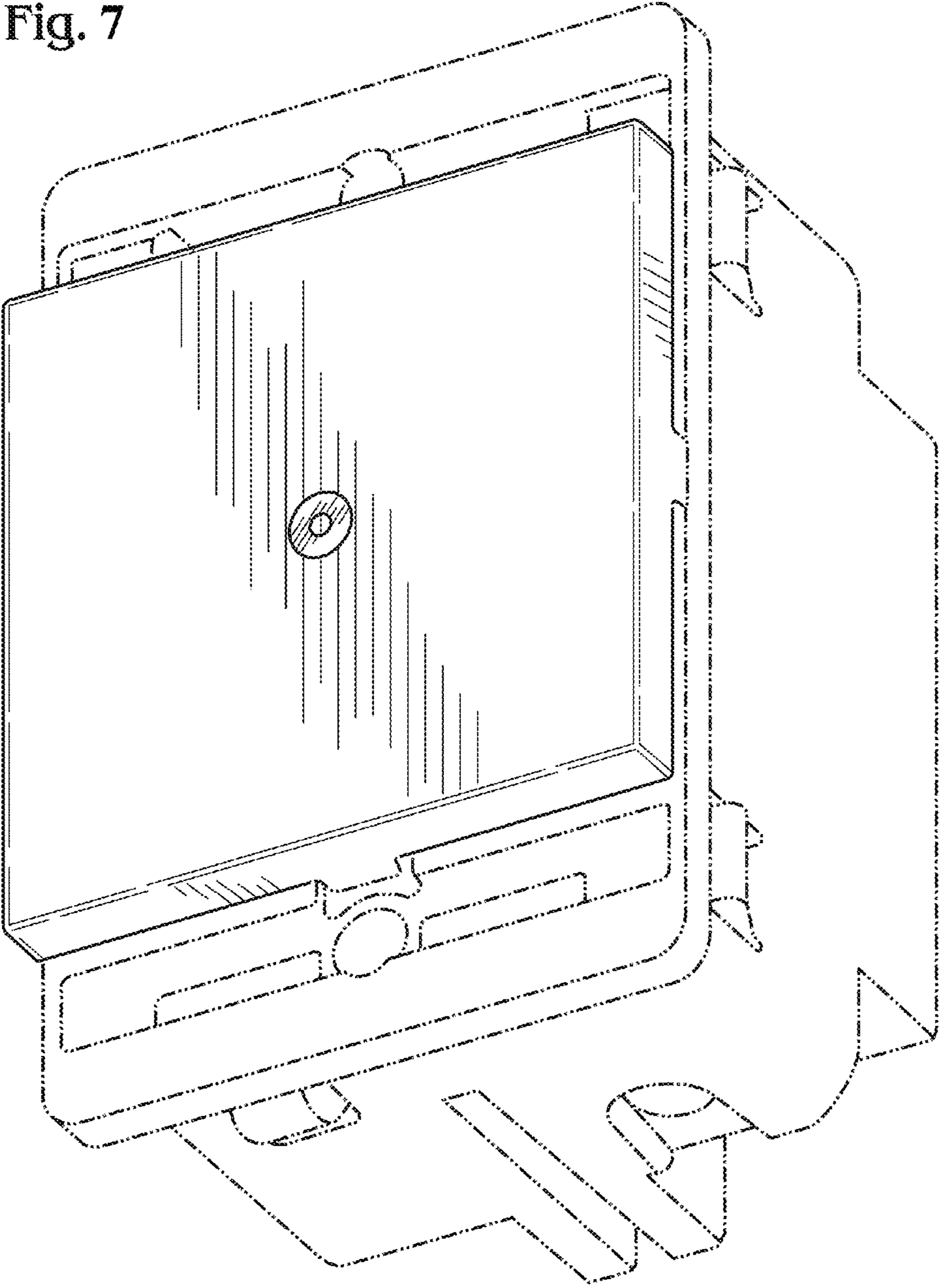

Fig. 8

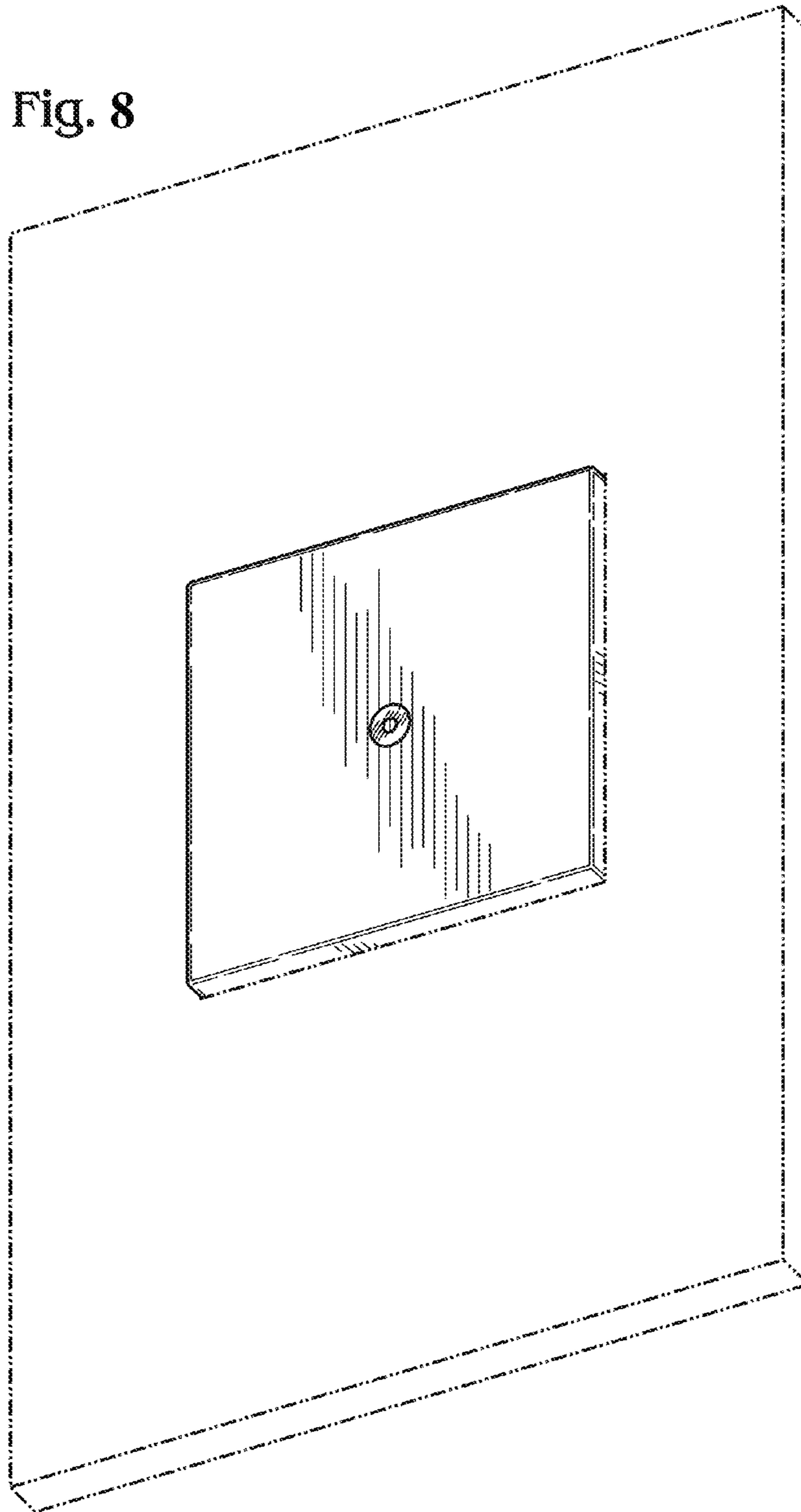

Fig. 9

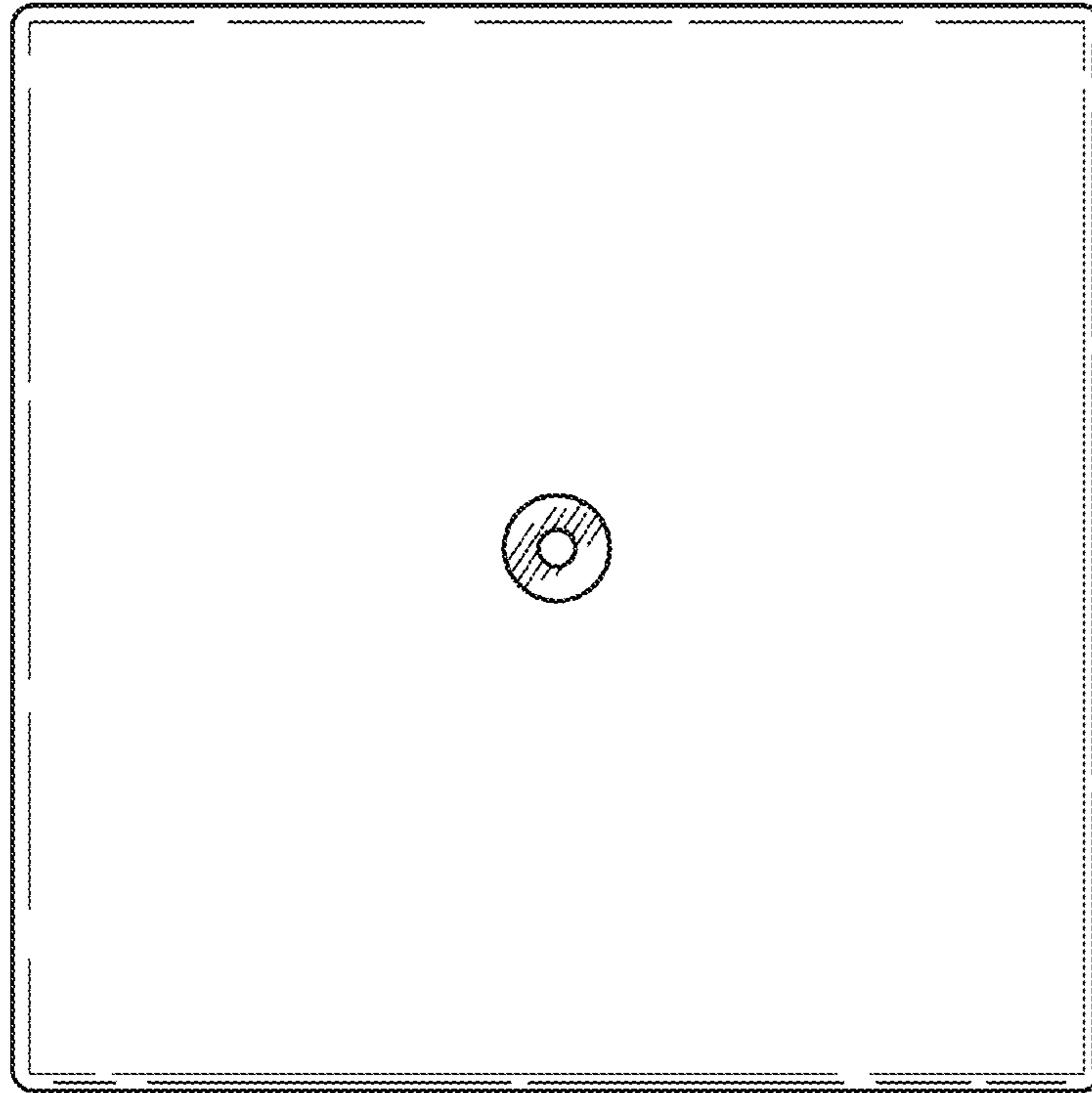

Fig. 10

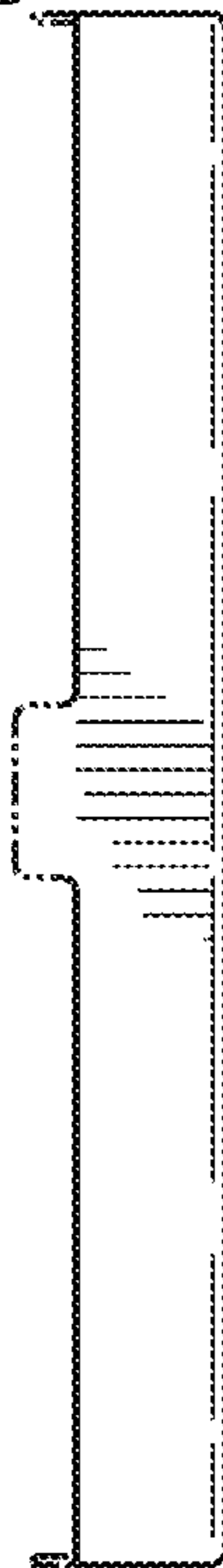

Fig. 11



Fig. 12

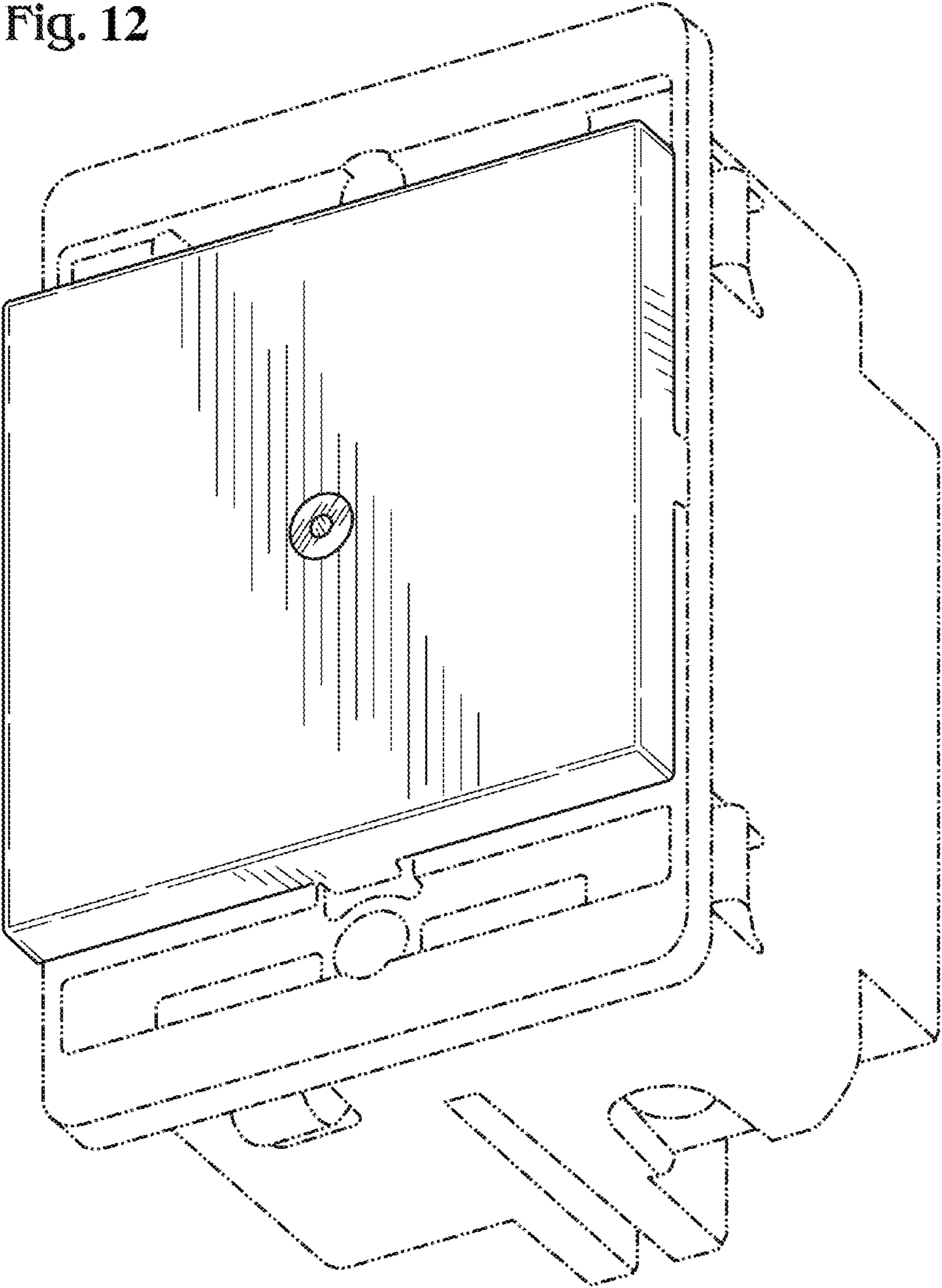

Fig. 13

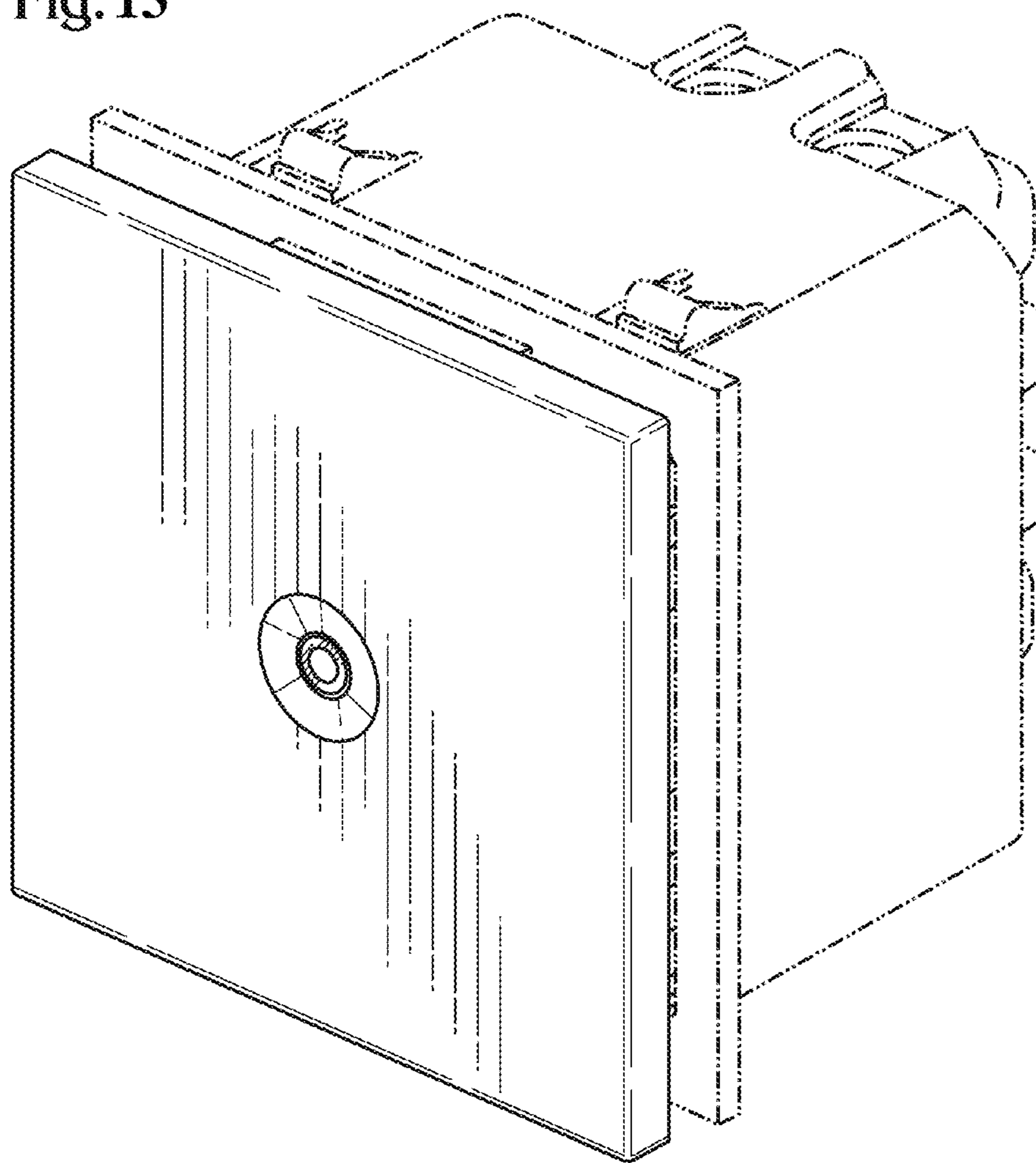

Fig. 14

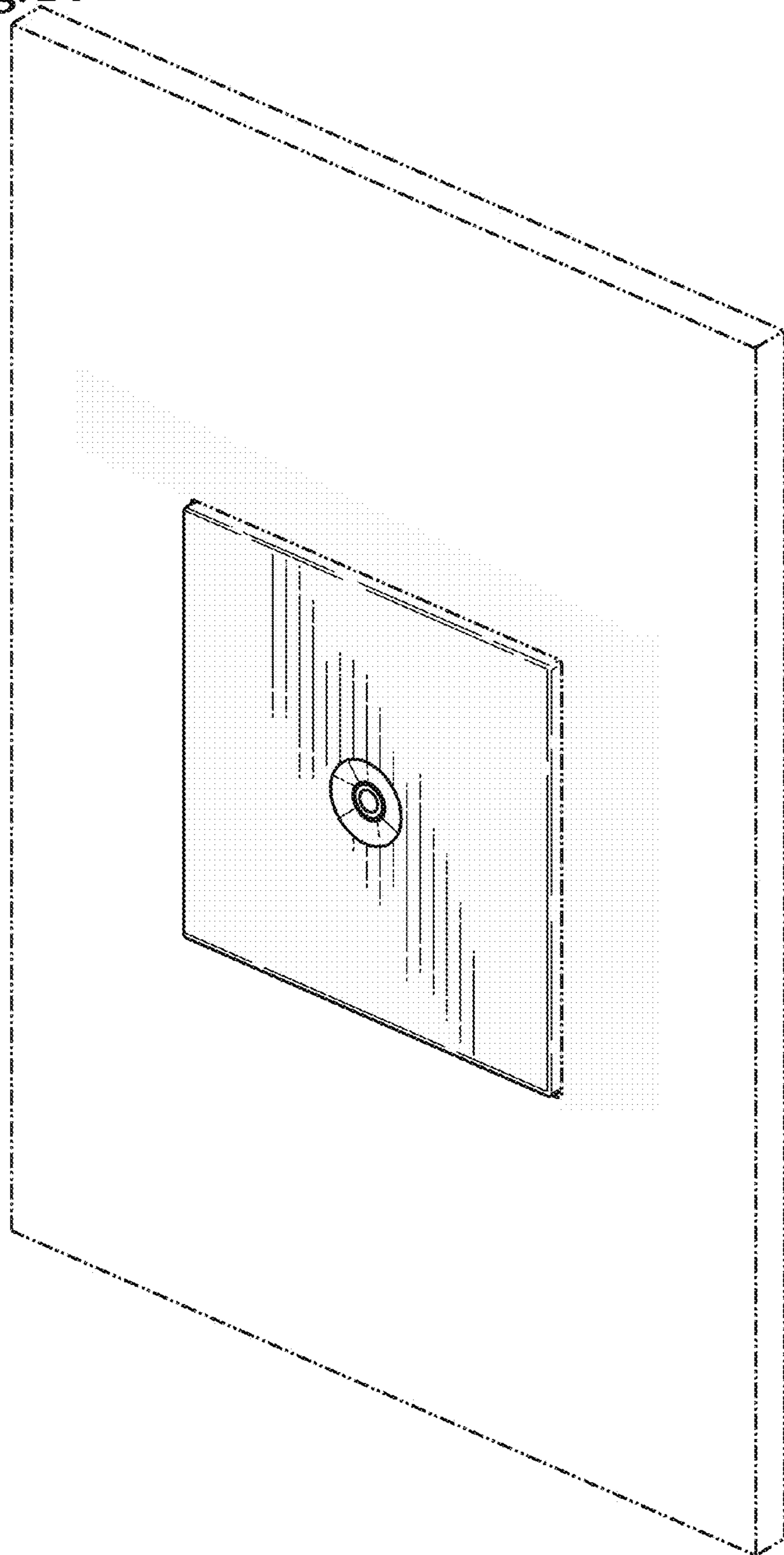

Fig. 15

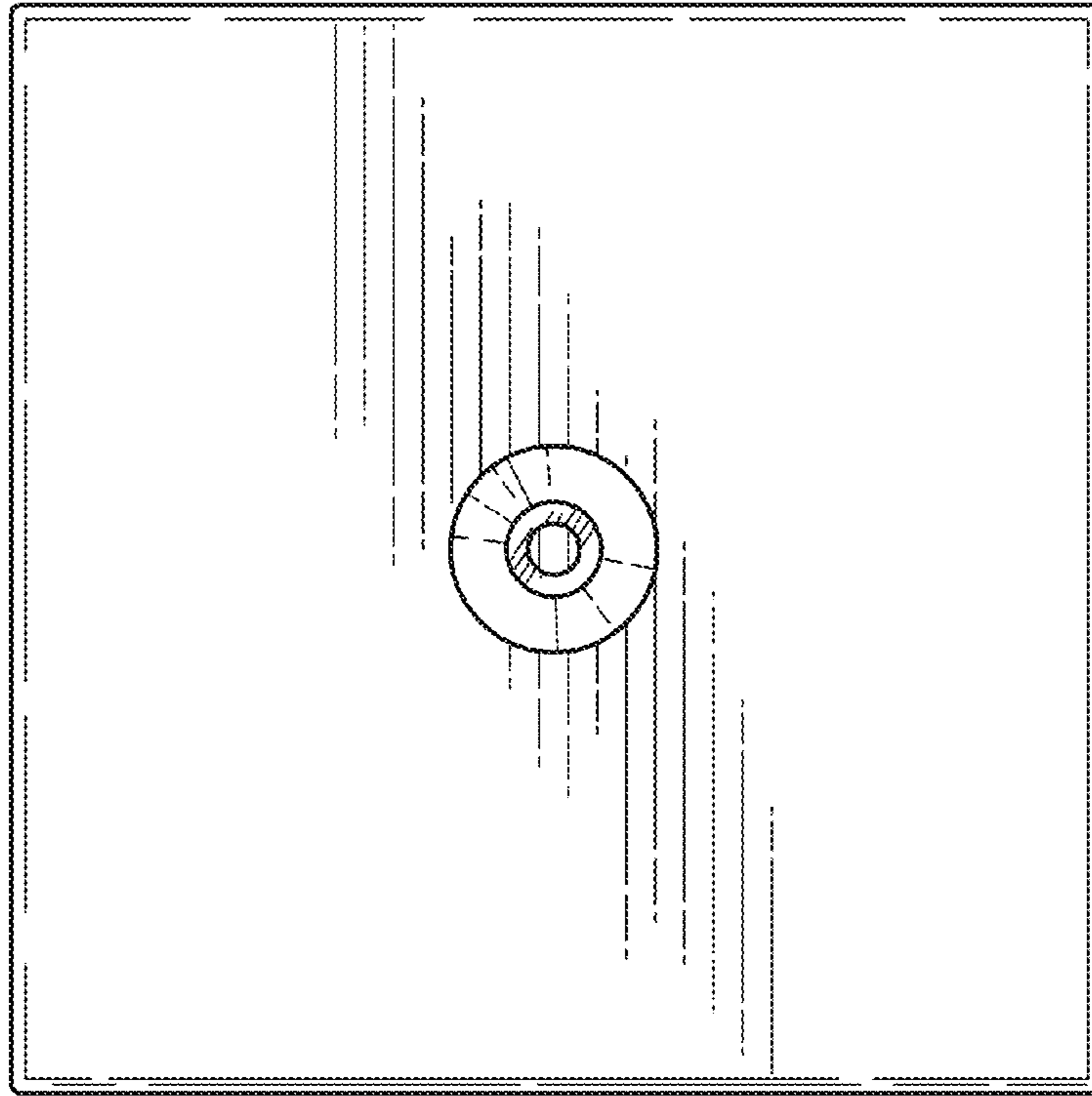

Fig. 16



Fig. 17

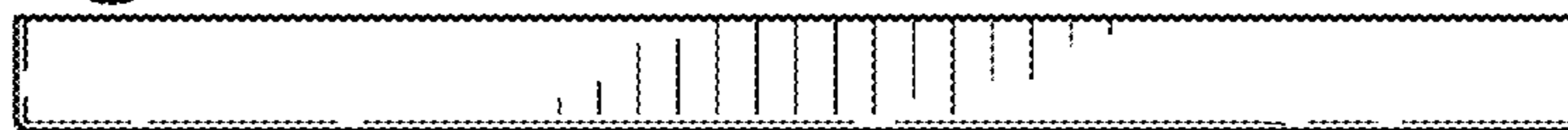

Fig. 18

