



US00D709431S

(12) **United States Design Patent**  
**Karkow et al.**

(10) **Patent No.:** **US D709,431 S**  
(45) **Date of Patent:** **\*\* Jul. 22, 2014**

- (54) **AMPHIBIOUS AIRCRAFT HULL**
- (71) Applicant: **ICON Aircraft, Inc.**, Los Angeles, CA (US)
- (72) Inventors: **Jon Karkow**, Tehachapi, CA (US);  
**Brant R. Savander**, Ann Arbor, MI (US)
- (73) Assignee: **Icon Aircraft, Inc.**, Los Angeles, CA (US)

(\*\*) Term: **14 Years**

(21) Appl. No.: **29/460,776**

(22) Filed: **Jul. 15, 2013**

(51) **LOC (10) Cl.** ..... **12-07**

(52) **U.S. Cl.**  
USPC ..... **D12/345; D12/324**

(58) **Field of Classification Search**  
USPC ..... D12/2, 3, 4, 16.1, 319, 324, 326-334,  
D12/337, 338, 339, 341, 344, 345;  
D21/430, 436, 441, 442, 446-450, 451,  
D21/452, 453; 244/2, 5, 6, 7 R, 7 A, 7 C, 8,  
244/13, 55, 56, 101, 106, 117 R, 119, 120,  
244/125, 17.19; 280/1.12, 1.21; 446/34-38,  
446/57-59, 230-236

See application file for complete search history.

(56) **References Cited**

**U.S. PATENT DOCUMENTS**

- D137,661 S \* 4/1944 Sheffield ..... D12/344
- D178,584 S \* 8/1956 Toth ..... D12/324

- 4,121,791 A \* 10/1978 Taylor et al. .... 244/120
- 4,962,978 A \* 10/1990 Weston ..... 244/105
- D325,021 S \* 3/1992 Mouton, Jr. .... D12/324
- D392,937 S \* 3/1998 Brichard et al. .... D12/324
- 5,913,493 A \* 6/1999 Labouchere ..... 244/105
- 6,113,028 A \* 9/2000 Lohse et al. .... 244/13
- D613,202 S \* 4/2010 Rodriguez et al. .... D12/3
- D620,392 S \* 7/2010 Rodriguez et al. .... D12/3
- D620,838 S \* 8/2010 Miralles et al. .... D12/3
- 8,177,162 B2 \* 5/2012 Karkow et al. .... 244/105
- 2006/0255208 A1 \* 11/2006 Hawkins ..... 244/105

\* cited by examiner

*Primary Examiner* — Caron D Veynar

*Assistant Examiner* — Martie K Holtje

(74) *Attorney, Agent, or Firm* — Martensen IP

(57) **CLAIM**

The ornamental design for an amphibious aircraft hull, as shown and described.

**DESCRIPTION**

FIG. 1 is a bottom, right front perspective view of an amphibious aircraft hull showing our new design;  
 FIG. 2 is a bottom, left rear perspective view thereof;  
 FIG. 3 is a front elevational view thereof;  
 FIG. 4 is a rear elevational view thereof;  
 FIG. 5 is a right side elevational view thereof;  
 FIG. 6 is a left side elevational view thereof;  
 FIG. 7 is a top plan view thereof; and,  
 FIG. 8 is a bottom plan view thereof.

The structural elements depicted by broken lines have been shown for the purpose of illustrating environmental features that form no part of the claimed design.

**1 Claim, 8 Drawing Sheets**

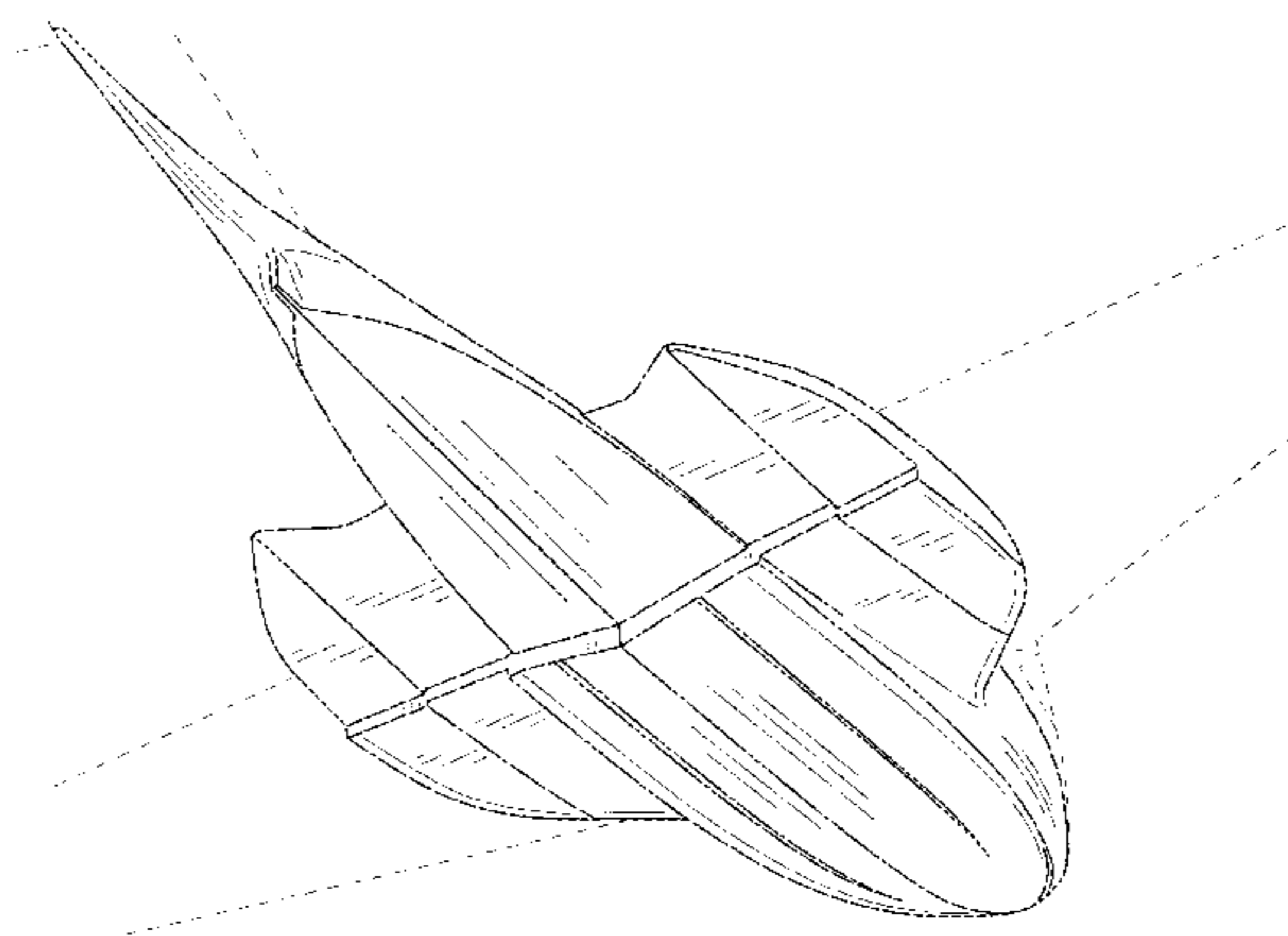
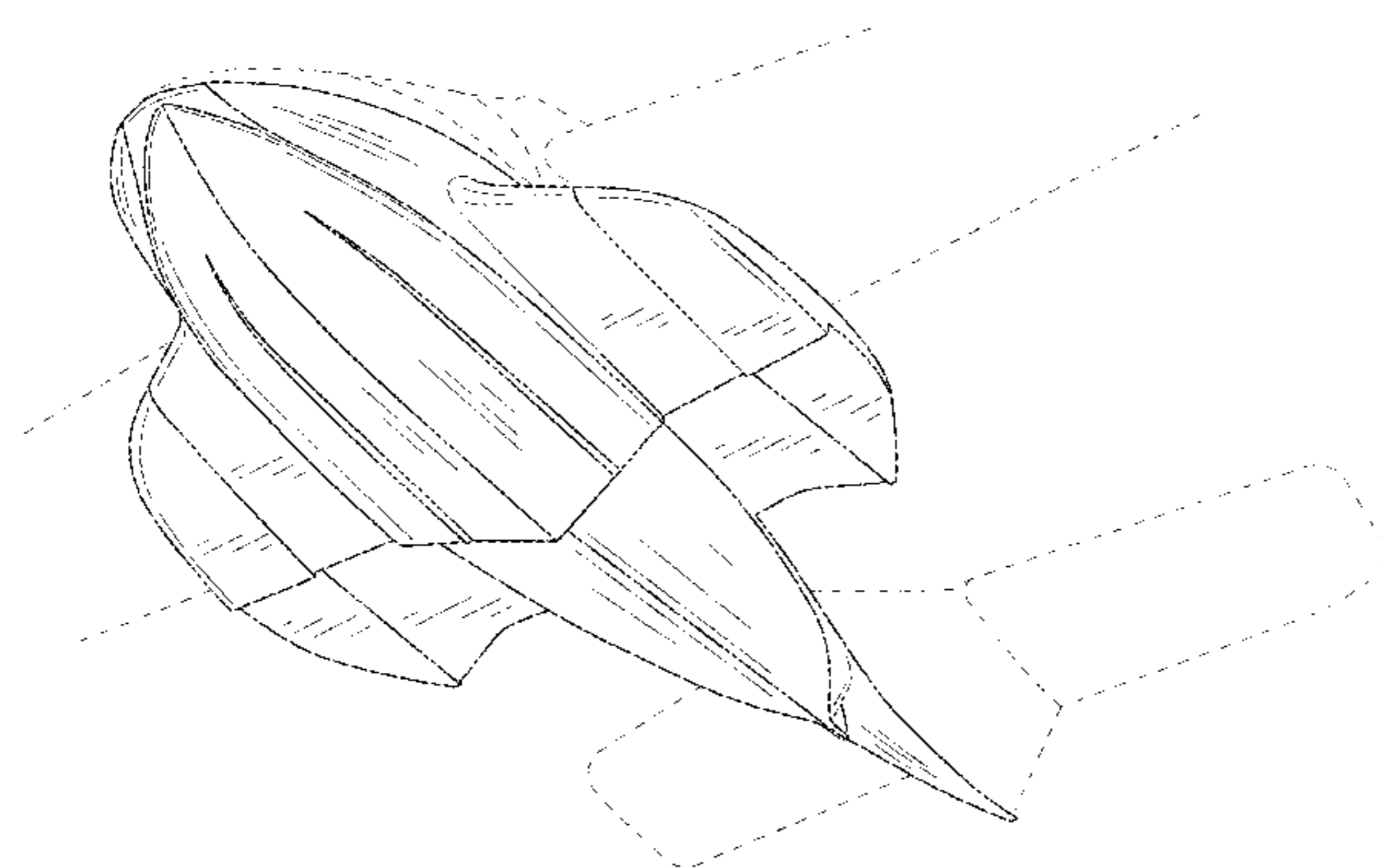

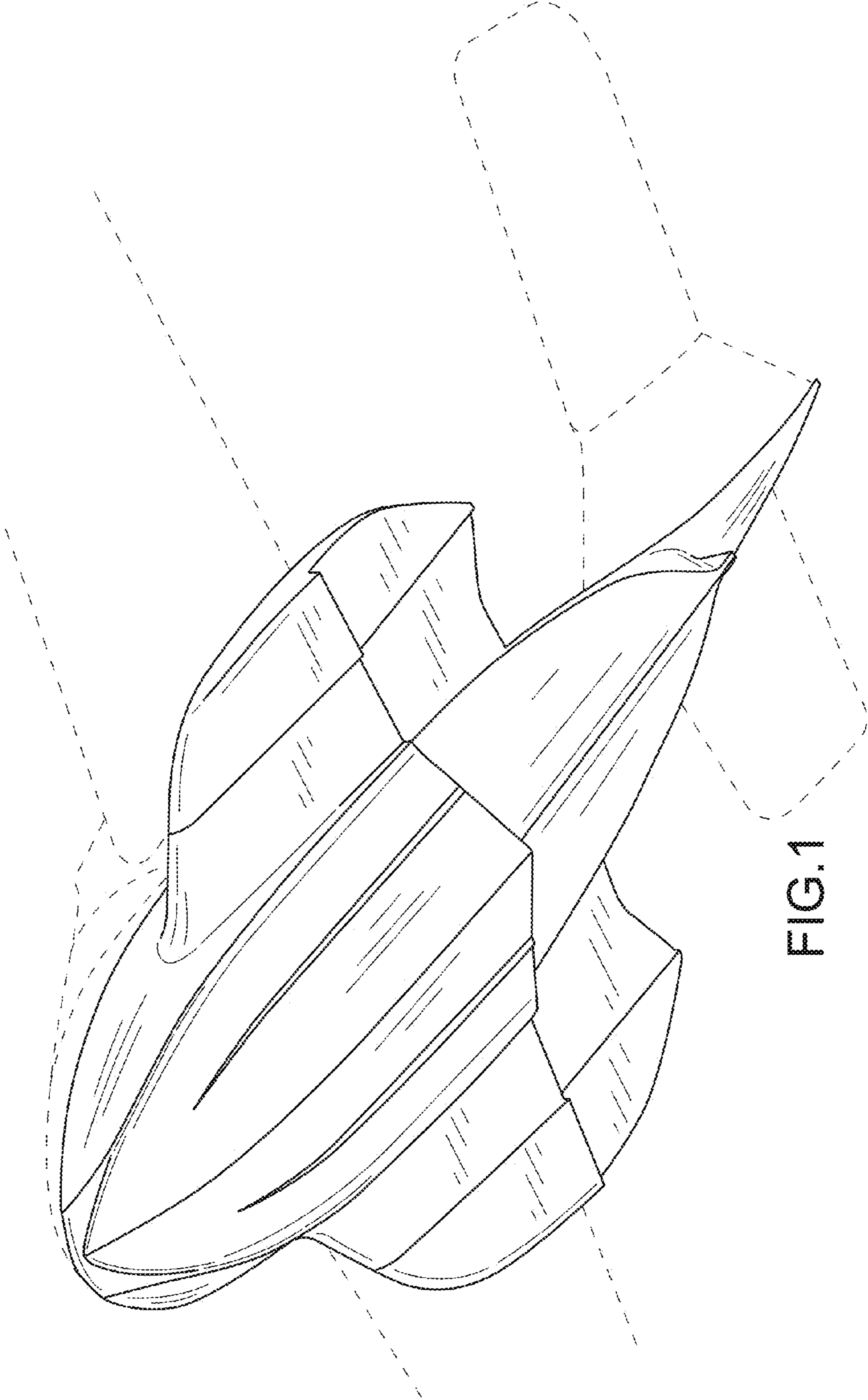

FIG.1

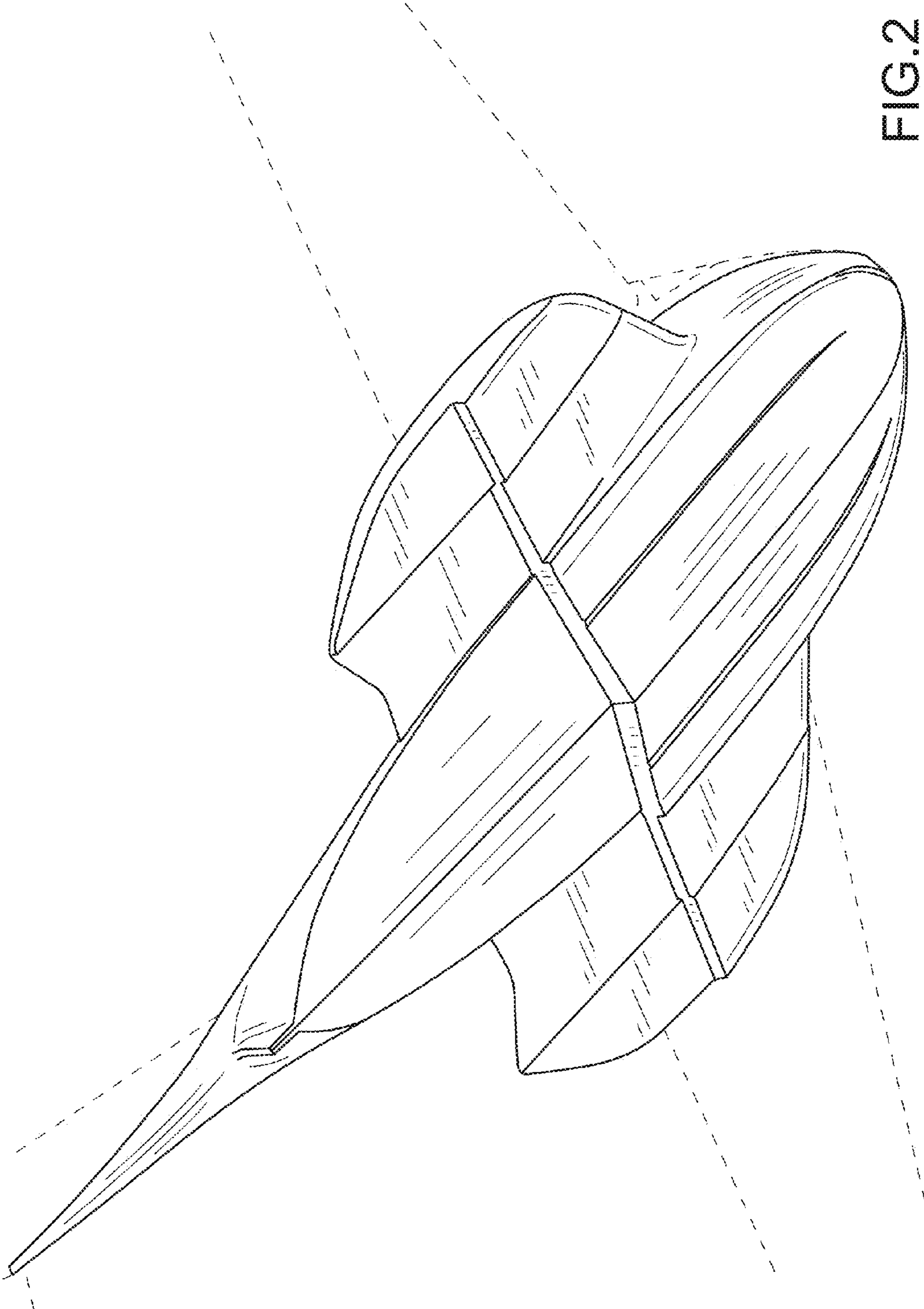

FIG.2

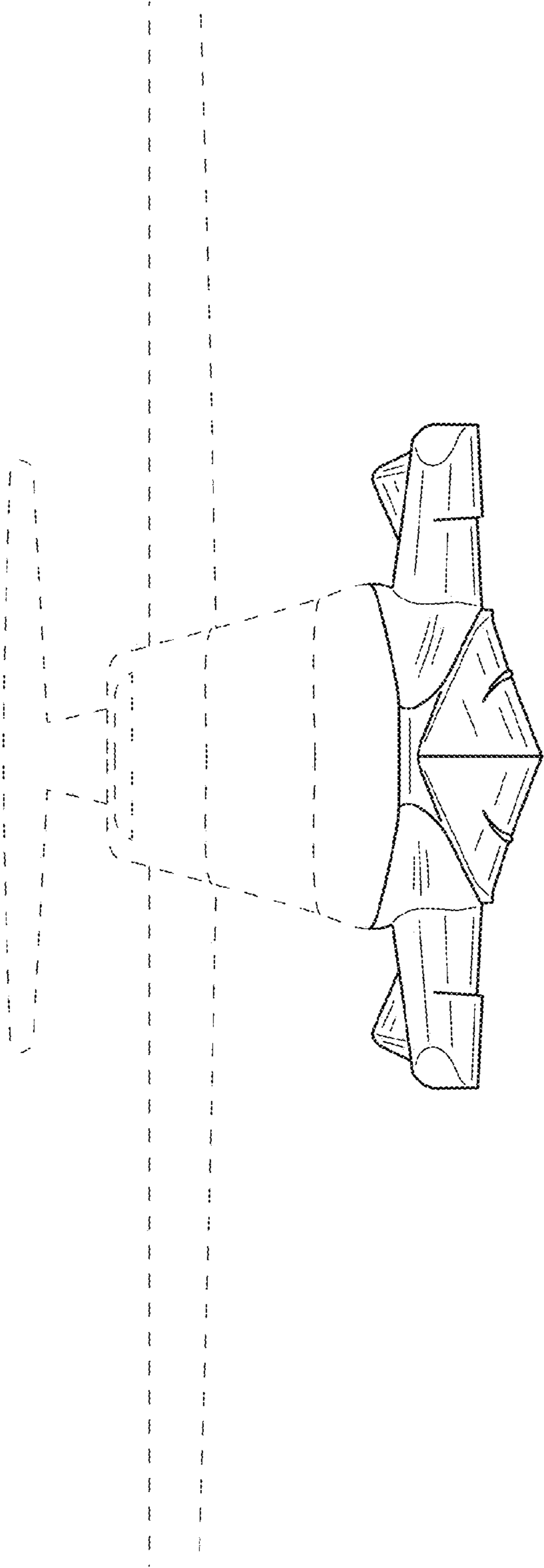

FIG.3

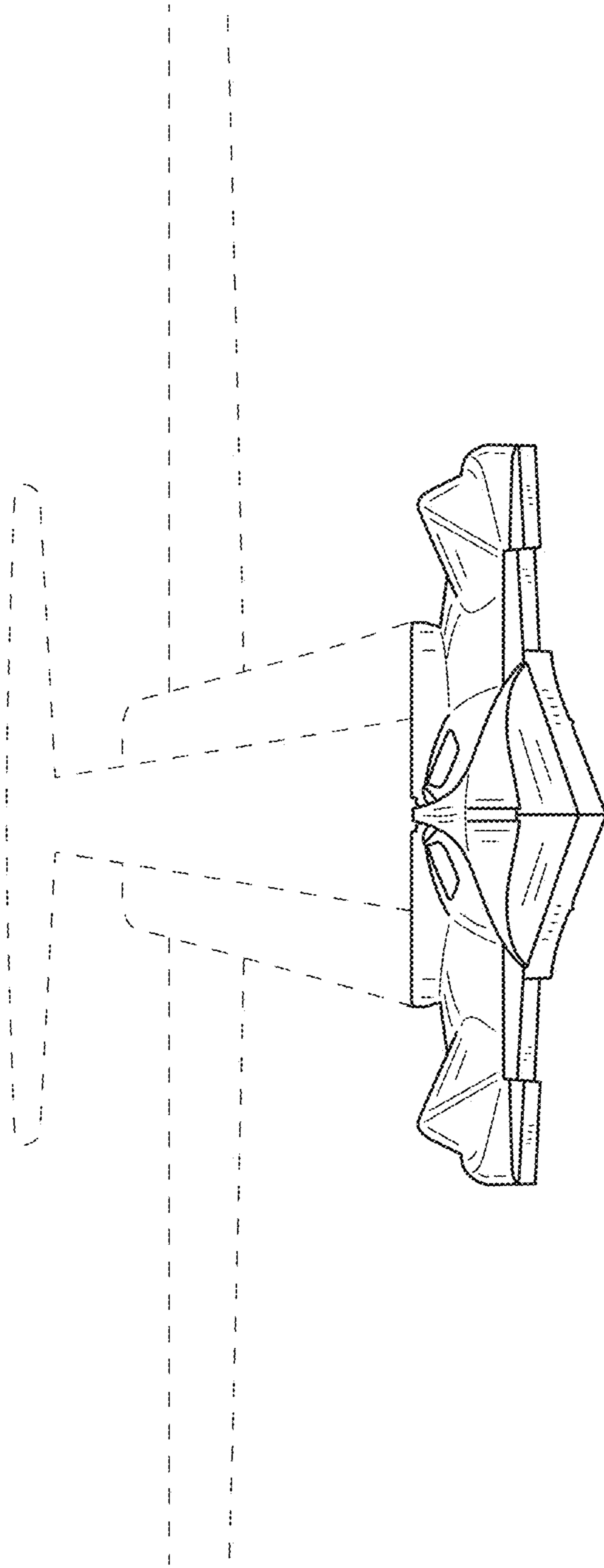

FIG.4

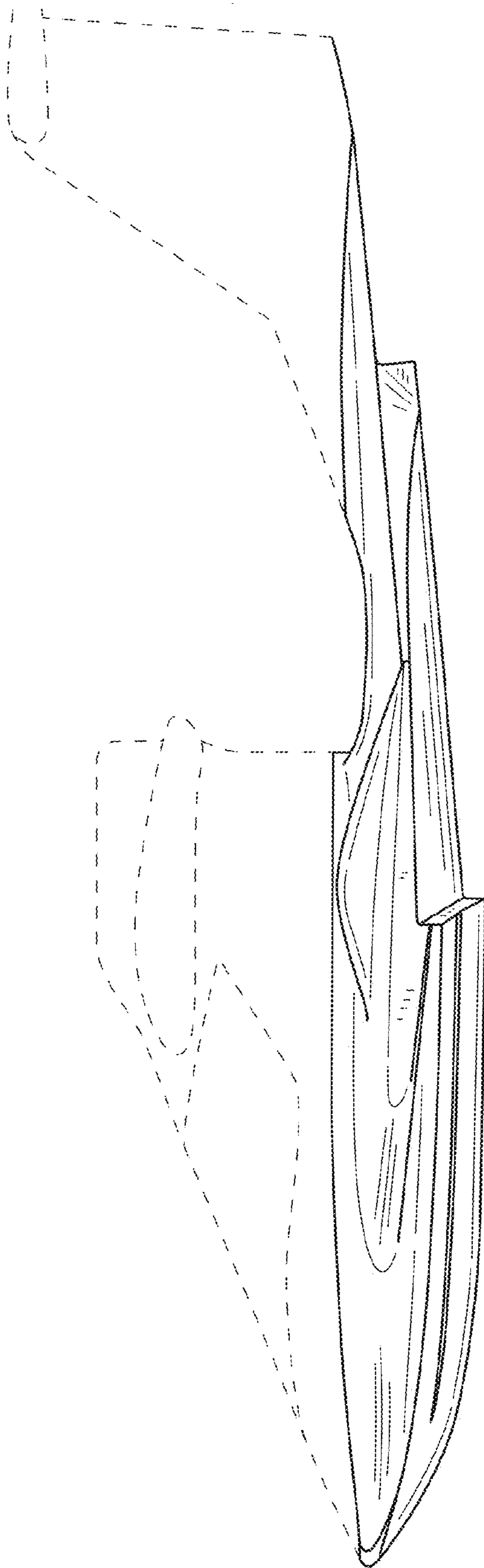

FIG.5

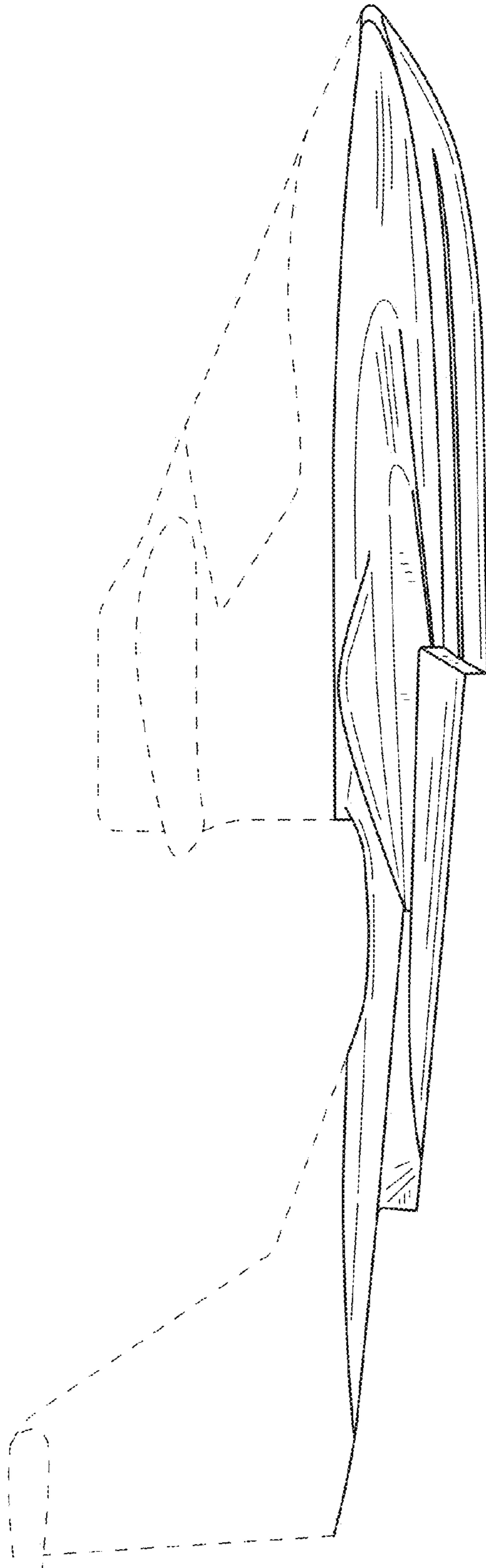

FIG.6

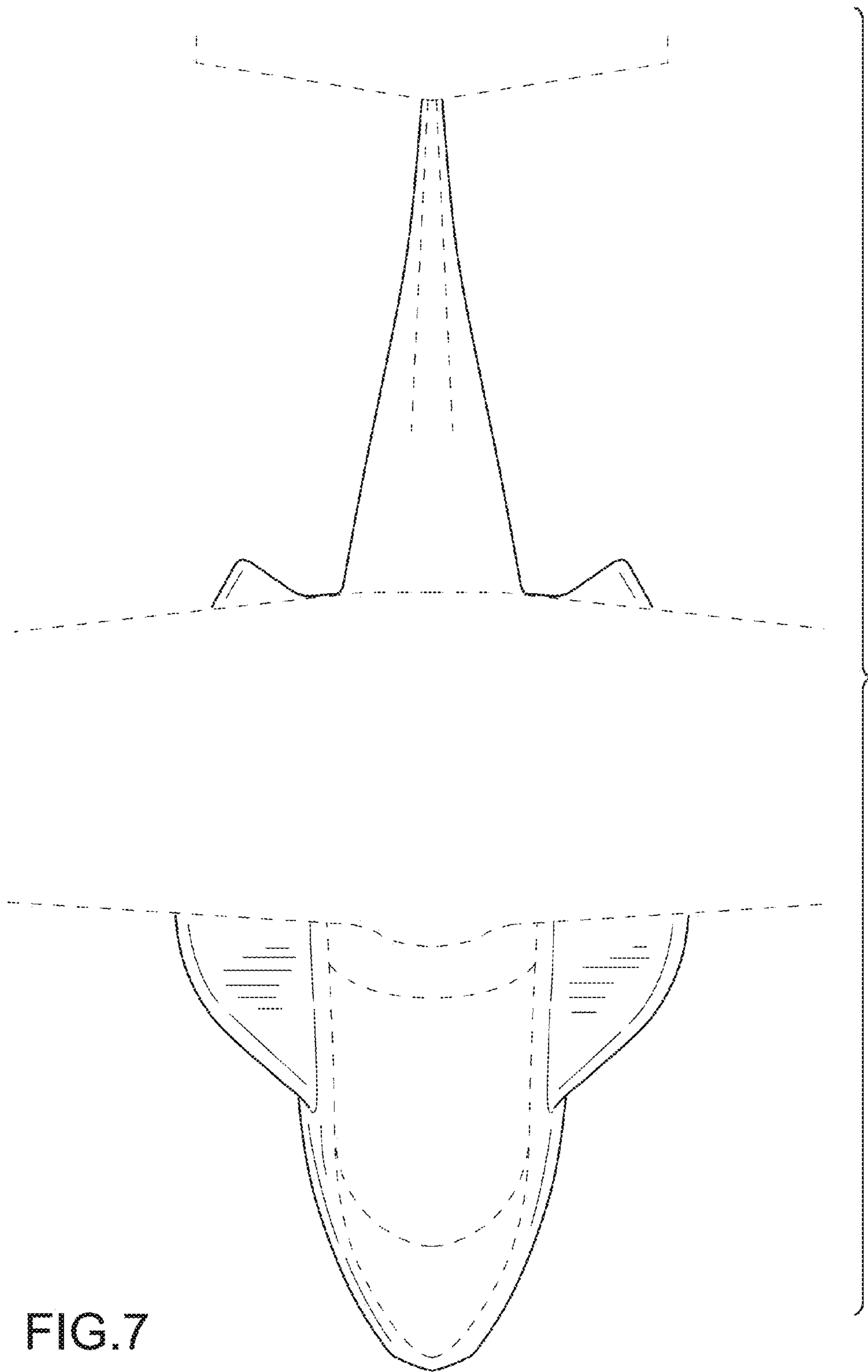

FIG.7



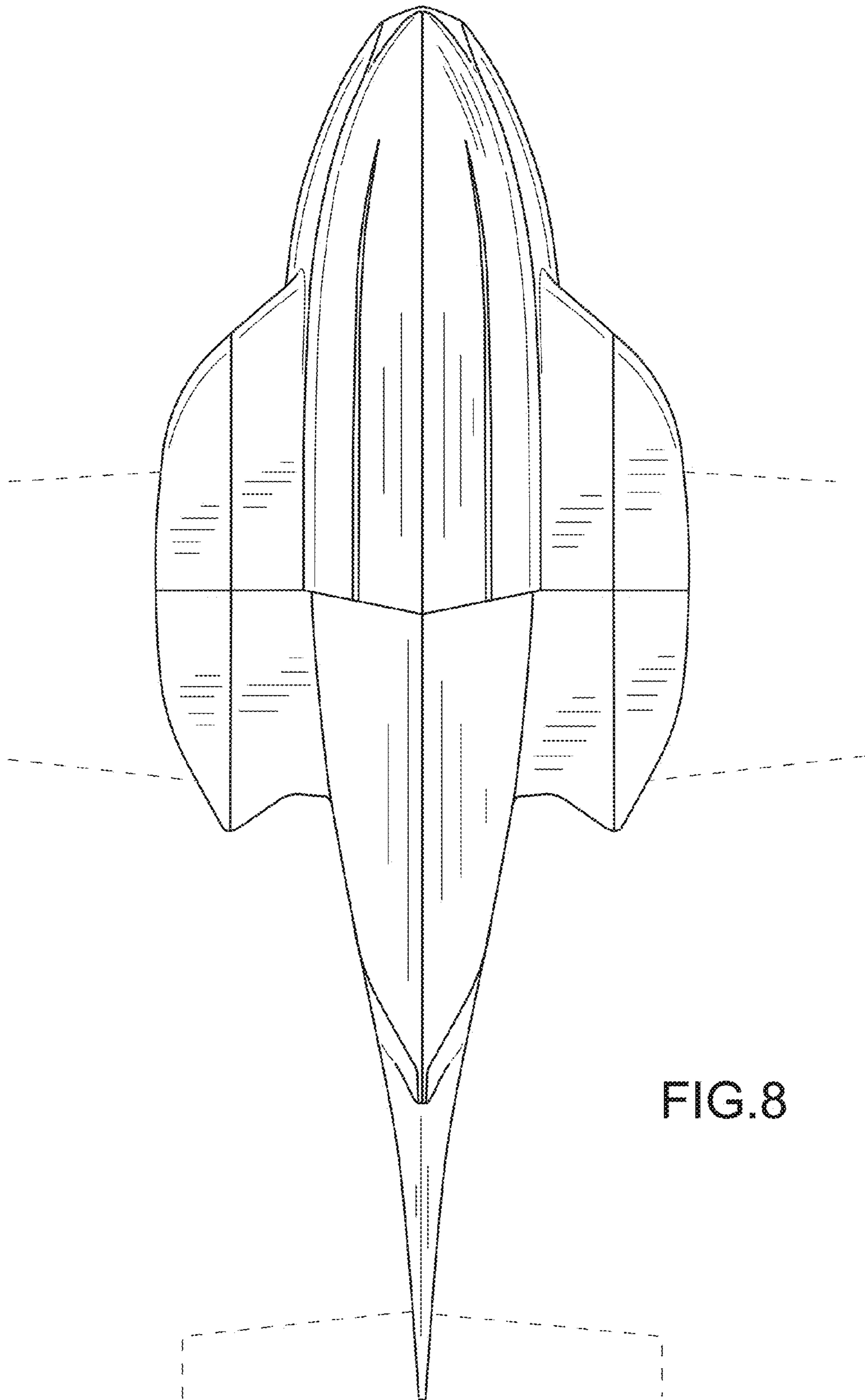

FIG.8