



US00D709417S

(12) **United States Design Patent**  
**Jordan**

(10) **Patent No.:** **US D709,417 S**

(45) **Date of Patent:** **\*\* Jul. 22, 2014**

(54) **EAGLE INSIGNIA BADGE FOR A LIFT TRUCK OR THE LIKE**

(74) *Attorney, Agent, or Firm* — Chernoff, Vilhauer, McClung & Stenzel LLP

(75) Inventor: **D. Clark Jordan**, Boring, OR (US)

(57) **CLAIM**

The ornamental design for an eagle insignia badge for a lift truck or the like, as shown and described.

(73) Assignee: **Cascade Corporation**, Fairview, OR (US)

**DESCRIPTION**

(\*\*) Term: **14 Years**

(21) Appl. No.: **29/412,951**

(22) Filed: **Feb. 9, 2012**

(51) **LOC (10) Cl.** ..... **12-16**

(52) **U.S. Cl.**  
USPC ..... **D12/190**

(58) **Field of Classification Search**  
USPC ..... D12/190, 192, 400, 90, 91, 92, 199,  
D12/197, 86, 171, 169, 163, 110, 114;  
D11/211, 81, 157, 133, 172; D20/11,  
D20/23, 24, 25, 30, 31, 32; 293/102, 115;  
40/413, 591, 592; 428/31

See application file for complete search history.

FIG. 1 is an isometric view from the upper right front of an eagle insignia badge for a lift truck or the like, including a first embodiment of my new design;  
FIG. 2 is a front elevational view thereof;  
FIG. 3 is a left side elevational view thereof;  
FIG. 4 is a right side elevational view thereof;  
FIG. 5 is a top plan view thereof;  
FIG. 6 is a bottom plan view thereof;  
FIG. 7 is a rear side elevational view thereof;  
FIG. 8 is an isometric view from the upper right front of an eagle insignia badge for a lift truck or the like including a second embodiment of my new design;  
FIG. 9 is a front elevational view thereof;  
FIG. 10 is a left side elevational view thereof;  
FIG. 11 is a right side elevational view thereof;  
FIG. 12 is a top plan view thereof;  
FIG. 13 is a bottom plan view thereof; and,  
FIG. 14 is a rear side elevational view thereof.

(56) **References Cited**

**U.S. PATENT DOCUMENTS**

D62,398 S	5/1923	Hunt	
D182,489 S *	4/1958	McKeever	D11/137
D233,242 S	10/1974	Brotman	
4,050,231 A *	9/1977	Lopez et al.	368/273
D254,403 S	3/1980	Brouwer	

(Continued)

**OTHER PUBLICATIONS**

Cascade Corporation, Design U.S. Appl. No. 29/417,483, entitled Eagle Insignia Badge for a Machine, filed Apr. 4, 2012, 3 pages.

(Continued)

The broken lines in FIGS. 1, 2, 8, and 9, outlining the eagle shape of the front layer of the badge, and the broken lines outlining the front layer of the badge in FIGS. 3-6 and 10-13 are for illustrative purposes only and form no part of the claimed design. The thickness of the rear layer of the insignia badge as shown in FIGS. 1 and 3-6 is shown foreshortened as represented by generally wavy parallel broken lines which are for illustrative purposes only and form no part of the claimed design, as no specific thickness of either layer is claimed as a part of the design.

The eagle shape of the front layer of the insignia badge, as shown outlined in broken line in FIGS. 2 and 9, is part of a trademark of Cascade Corporation, an Oregon corporation.

*Primary Examiner* — Katrina A Betton

**1 Claim, 6 Drawing Sheets**

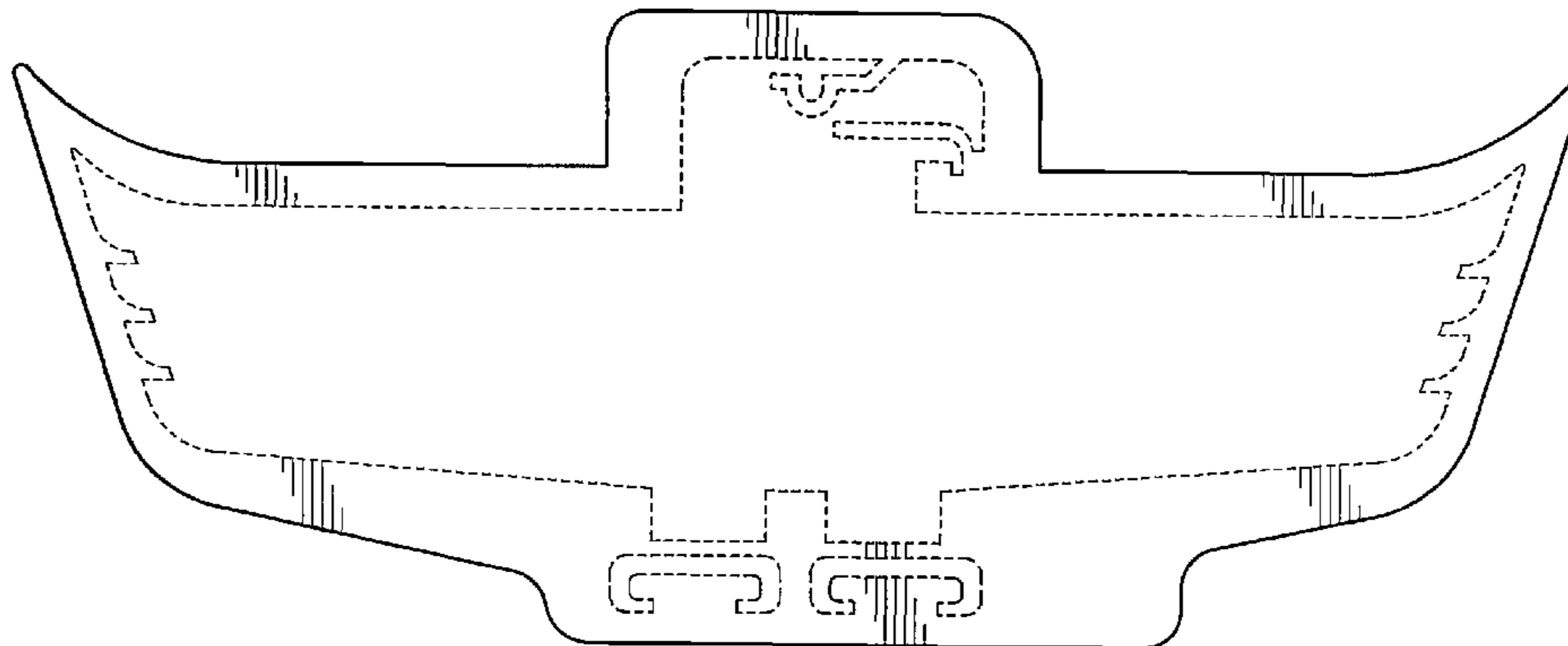

(56)

**References Cited**

U.S. PATENT DOCUMENTS

D272,424 S 1/1984 Stahel  
D325,888 S 5/1992 Carroll  
D340,205 S \* 10/1993 Ilaria et al. .... D11/137  
D356,637 S \* 3/1995 El-Assir ..... D23/367  
D379,000 S \* 4/1997 Choi ..... D12/213  
D444,000 S \* 6/2001 Jackson ..... D6/419  
D451,841 S \* 12/2001 Kapustinski ..... D11/162  
D469,395 S \* 1/2003 Himsl et al. .... D12/400  
D496,413 S \* 9/2004 Weiser ..... D21/608  
D496,696 S \* 9/2004 Weiser ..... D21/606  
D504,376 S 4/2005 Tsai  
D520,403 S 5/2006 Schumacher

D585,776 S 2/2009 Cowen et al.  
D646,211 S 10/2011 Hu  
D670,595 S \* 11/2012 Vandehey et al. .... D11/107  
D681,126 S \* 4/2013 Bengyak ..... D20/30  
D700,243 S \* 2/2014 Bengyak ..... D20/30

OTHER PUBLICATIONS

Cascade Corporation, Design U.S. Appl. No. 29/412,973, entitled  
Clamp Pad for a Lift Truck or the Like, filed Feb. 9, 2012, 5 pages.  
Cascade Corporation, U.S. Trademark Registration No. 1,153,668,  
entitled C & Design, registered May 12, 1981, 1 page.  
Cascade Corporation, www.cascorp.com, Sep. 12, 2012, 1 page.

\* cited by examiner

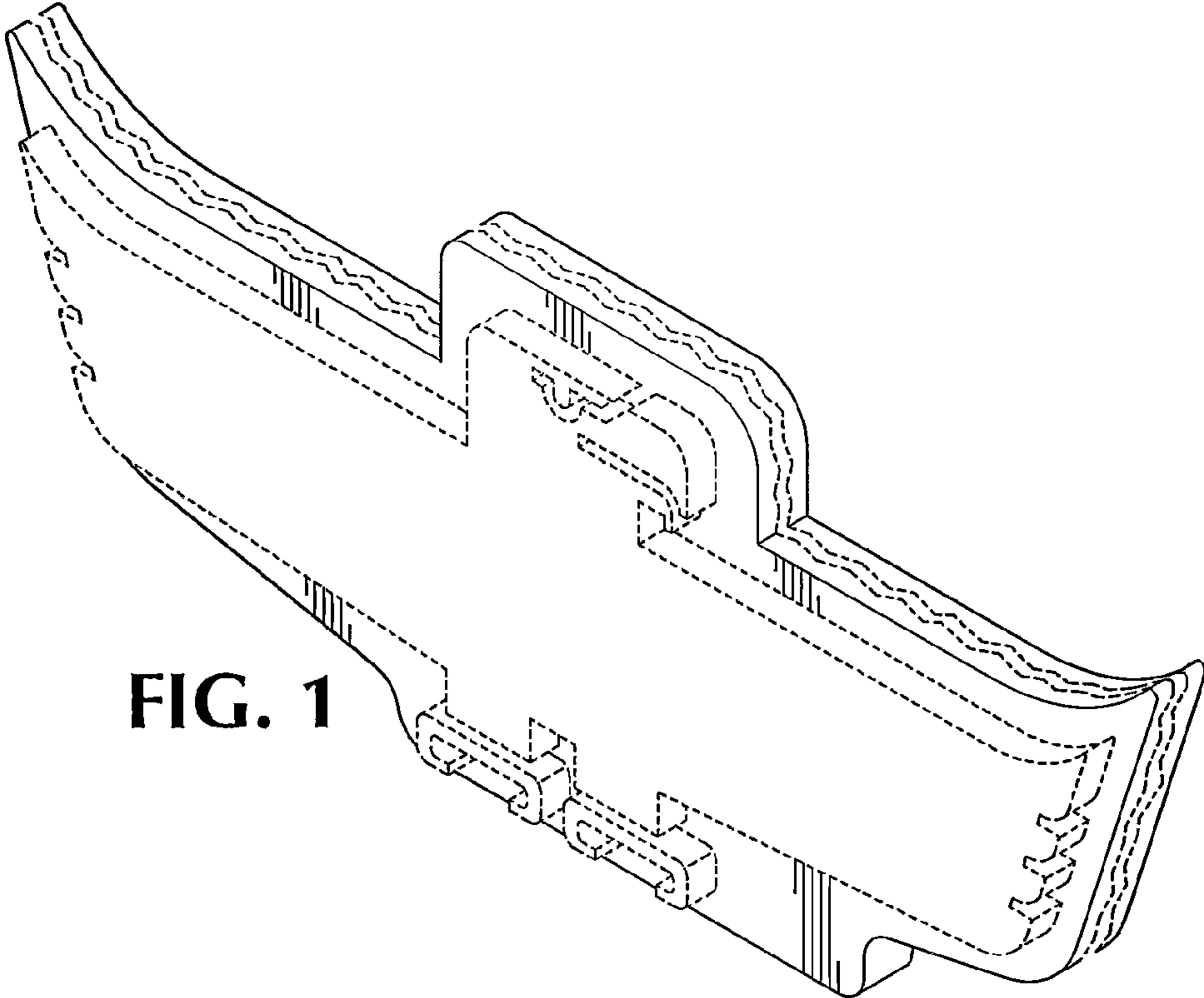

FIG. 1

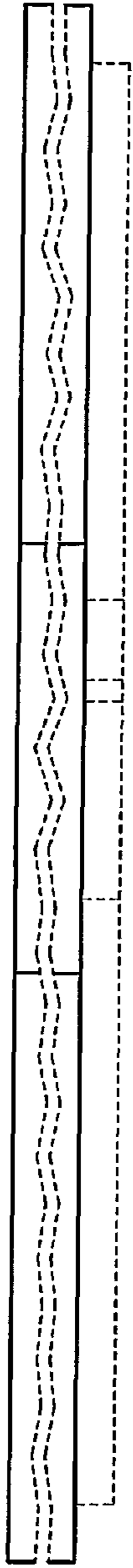

FIG. 5

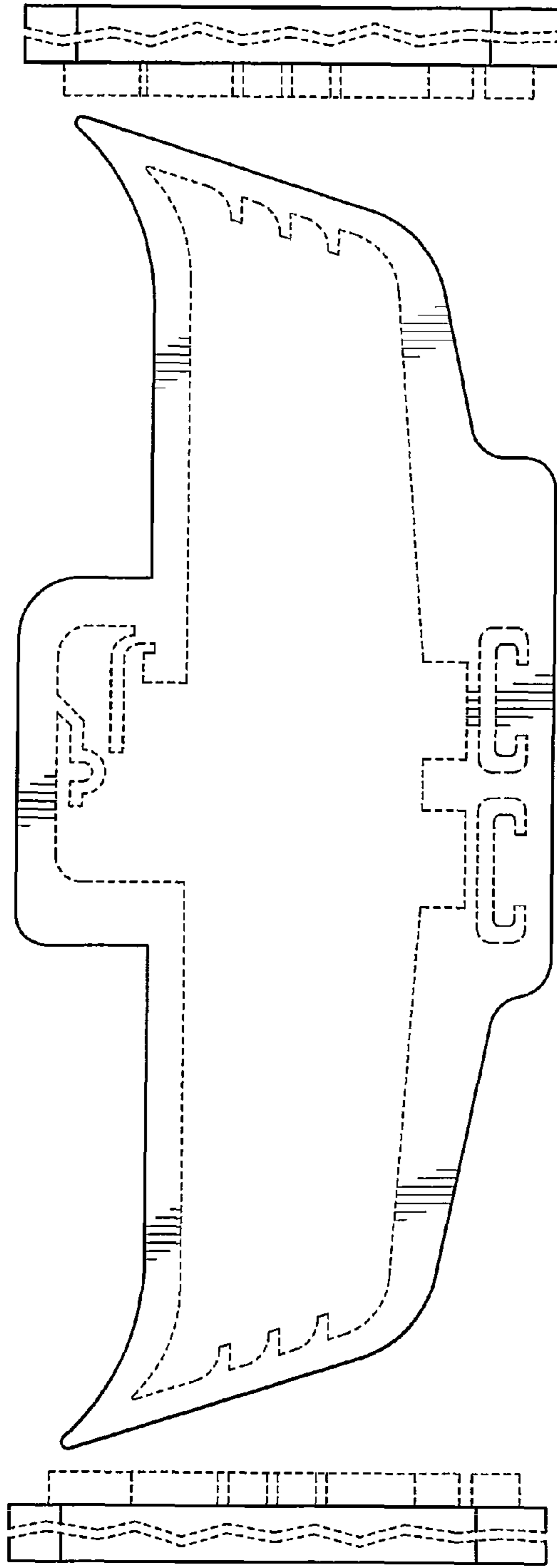

FIG. 3

FIG. 2

FIG. 4

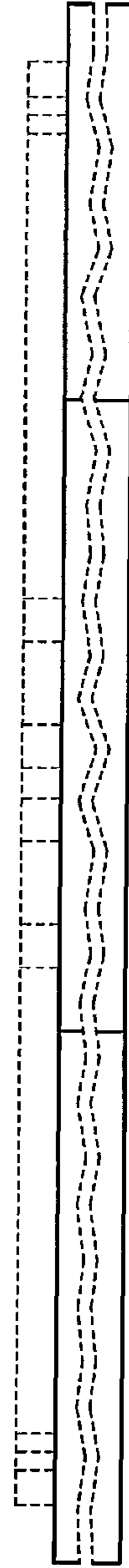

FIG. 6

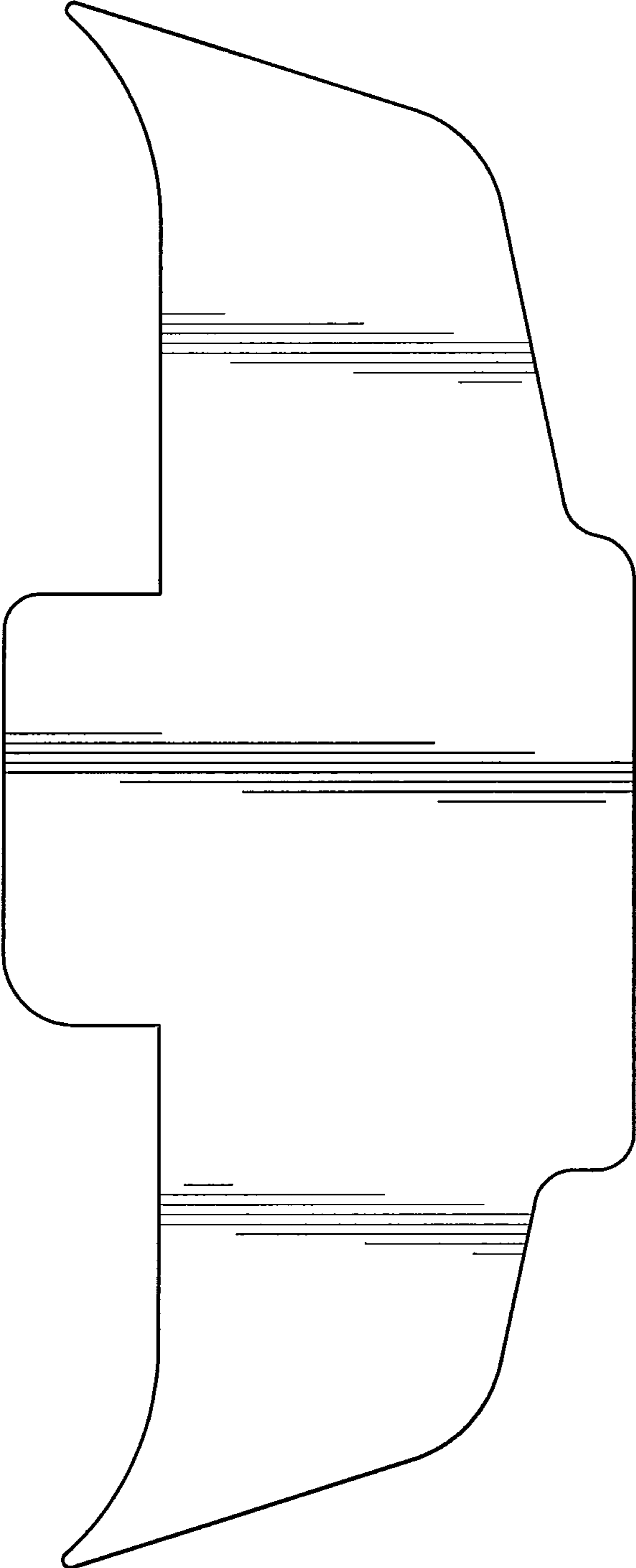
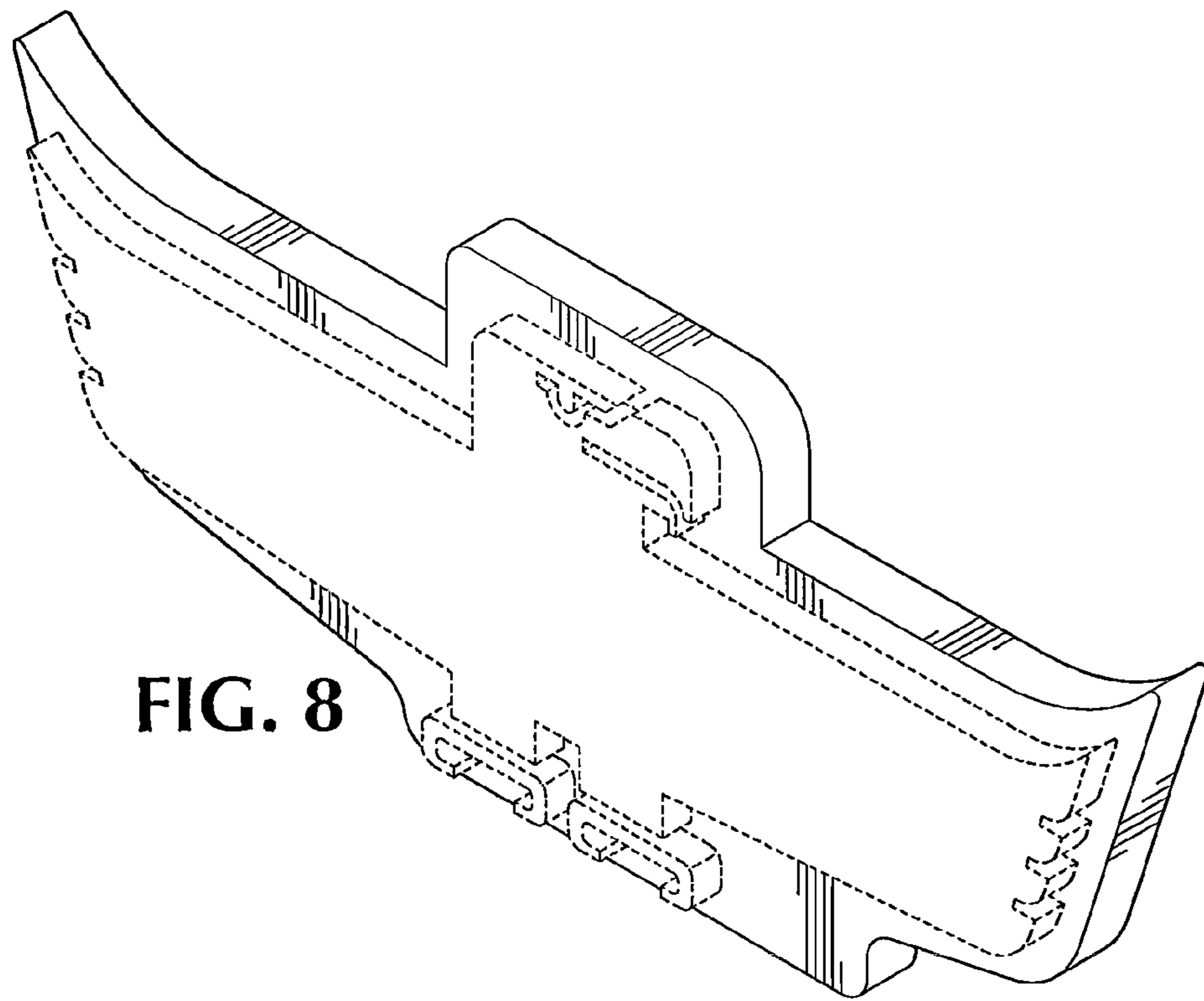

FIG. 7



**FIG. 8**



FIG. 12

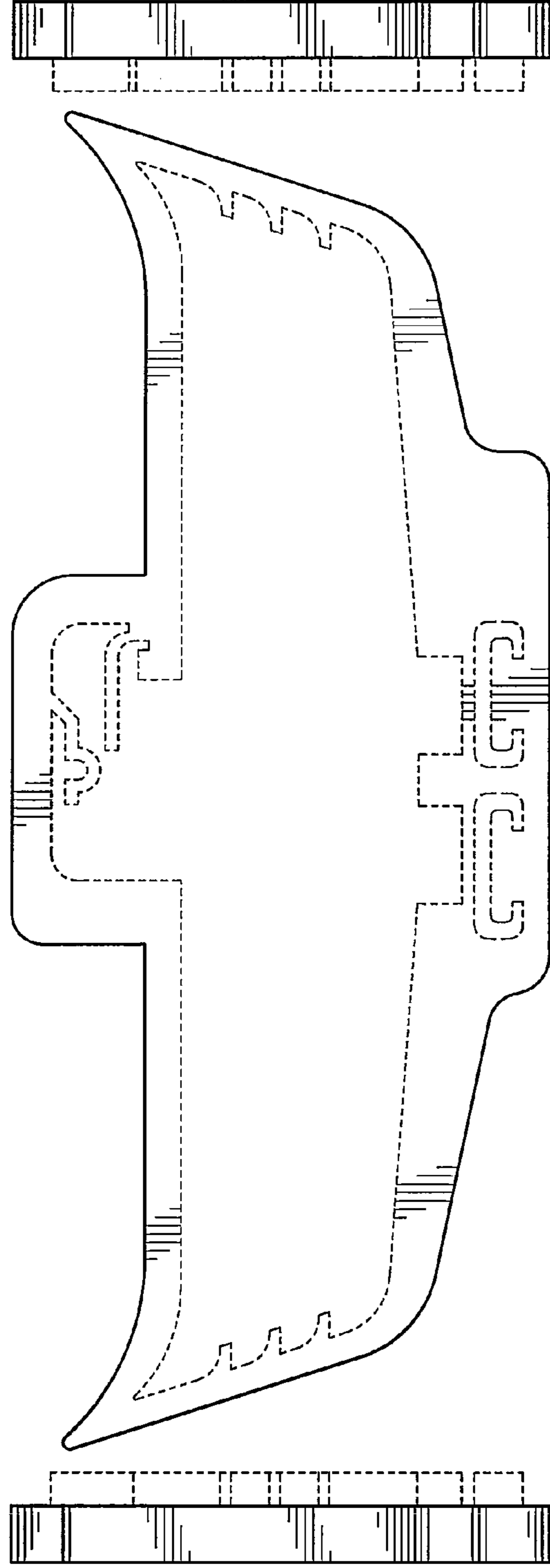

FIG. 10

FIG. 9

FIG. 11



FIG. 13

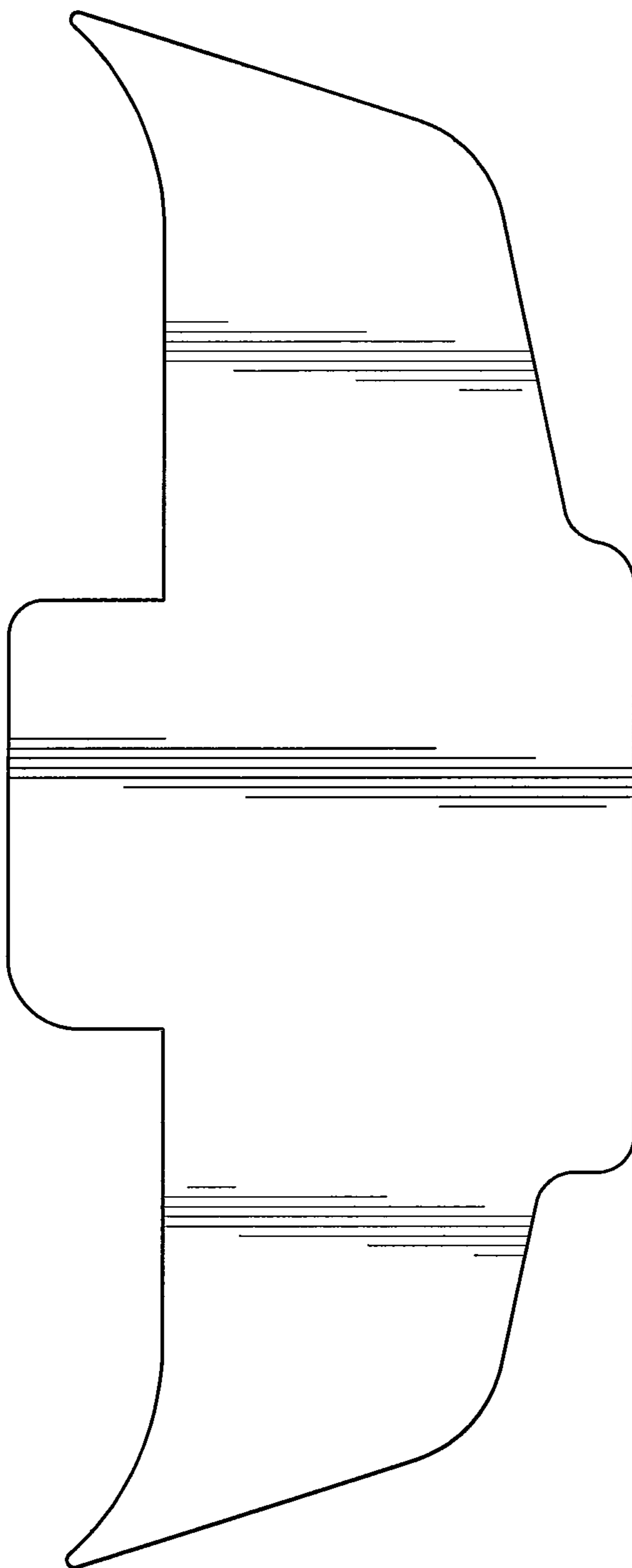

FIG. 14