



US00D709212S

(12) **United States Design Patent**
Peltola et al.

(10) **Patent No.:** **US D709,212 S**
(45) **Date of Patent:** **** Jul. 15, 2014**

- (54) **DAY CAB MARKER LAMP**
- (75) Inventors: **Wallace A. Peltola**, Sammamish, WA (US); **Steven H. Hovind**, Bellevue, WA (US)
- (73) Assignee: **PACCAR Inc**, Bellevue, WA (US)
- (**) Term: **14 Years**
- (21) Appl. No.: **29/415,675**
- (22) Filed: **Mar. 13, 2012**
- (51) **LOC (10) Cl.** **26-06**
- (52) **U.S. Cl.**
USPC **D26/28**
- (58) **Field of Classification Search**
USPC D26/28-36; 362/459-468, 475-478,
362/485-487, 61, 80-83
See application file for complete search history.

(56) **References Cited**

U.S. PATENT DOCUMENTS

- D500,153 S * 12/2004 Stephens et al. D26/28
- D530,437 S * 10/2006 Neufeglise et al. D26/28
- D640,181 S * 6/2011 Calvin et al. D12/345

OTHER PUBLICATIONS

- “AeroCab,” Kenworth Truck Company, Kirkland, Washington, 1993, 5-page brochure.
- “AeroCab,” Kenworth Truck Company, Kirkland, Washington, as early as 1995, 3-page brochure.
- “AG130 Front Air Suspension,” Kenworth Truck Company, Kirkland, Washington, 2008, 2-page brochure.
- “C500B,” Kenworth Truck Company, Kirkland, Washington, as early as 1990, 4-page brochure.
- “Cabovers,” Peterbilt Motors Company, Newark, California, as early as 2000, 7-page brochure.
- “Class Pays, Construction Trucks,” Peterbilt Motors Company, Denton, Texas, Nov. 2003, 16-page brochure.
- “Class Pays, Ergonomic Dash,” Peterbilt Motors Company, Denton, Texas, Mar. 2000, 2-page brochure.

- “Class Pays, Medium Duty,” Peterbilt Motors Company, Denton, Texas, Sep. 2000, 12-page brochure.
- “Class Pays, Platinum Interior,” Peterbilt Motors Company, Denton, Texas, May 2005, 4-page brochure.
- “Class Pays, Refuse Trucks,” Peterbilt Motors Company, Denton, Texas, Sep. 2003, 2-page brochure.
- “Class Pays, Truck Models,” Peterbilt Motors Company, Denton, Texas, Mar. 2005, 24-page brochure.
- “Class Pays,” Peterbilt Motors Company, Denton, Texas, Nov. 1998, 10-page brochure.
- “Class Pays,” Peterbilt Motors Company, Denton, Texas, Sep. 1997, 10-page brochure.
- “Construction Trucks,” Canadian Kenworth Truck, Mississauga, Ontario, Canada, Jul. 1990, 16-page brochure.
- “Interiors,” Kenworth Truck Company, Kirkland, Washington, 2005, 16-page brochure.

(Continued)

Primary Examiner — Marcus Jackson
(74) *Attorney, Agent, or Firm* — Christensen O’Connor Johnson Kindness PLLC

(57) **CLAIM**

The ornamental design for a day cab marker lamp, as shown and described.

DESCRIPTION

FIG. 1 is a perspective view of a day cab marker lamp according to our new design;
 FIG. 2 is a front elevational view of the day cab marker lamp of FIG. 1;
 FIG. 3 is a rear elevational view of the day cab marker lamp of FIG. 1;
 FIG. 4 is a top plan view of the day cab marker lamp of FIG. 1;
 FIG. 5 is a right side elevational view of the day cab marker lamp of FIG. 1; and,
 FIG. 6 is a left side elevational view of the day cab marker lamp of FIG. 1.
 The subject matter shown in phantom lines is hereby disclaimed and forms no part of the claimed invention.

1 Claim, 4 Drawing Sheets

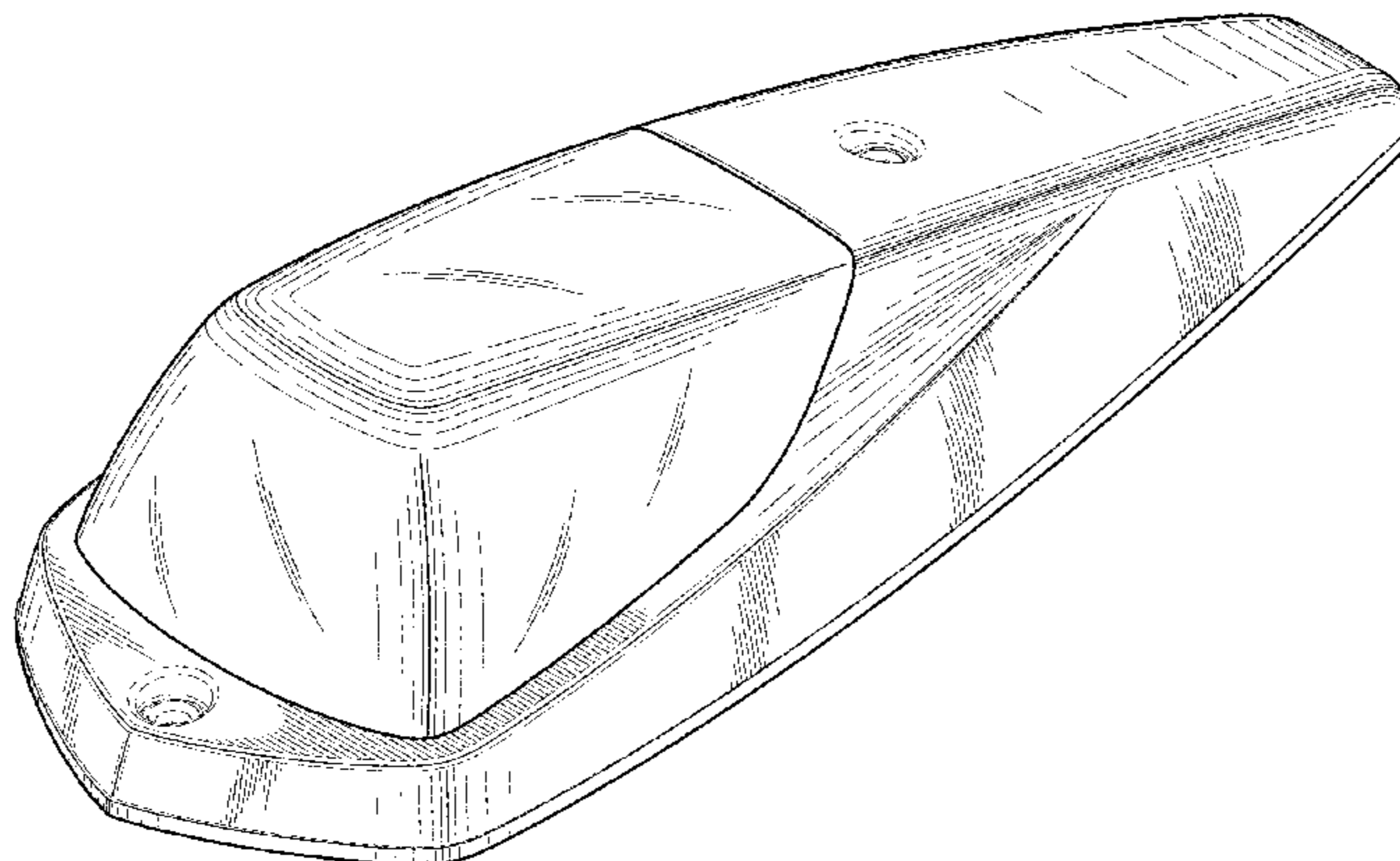

(56)

References Cited

OTHER PUBLICATIONS

- “Kenworth Truck Models,” Kenworth Truck Company, Kirkland, Washington, 2010, 16-page brochure.
- “K100E,” Kenworth Truck Company, Kirkland, Washington, 1984, 8-page brochure.
- “Model 320,” Peterbilt Motors Company, Denton, Texas, May 1996, 2-page brochure.
- “Model 330,” Peterbilt Motors Company, Denton, Texas, Oct. 1997, 3-page brochure.
- “Model 357 Heavy Haul,” Peterbilt Motors Company, Denton, Texas, Mar. 2005, 2-page brochure.
- “Model 357 Standard Specifications,” Peterbilt Motors Company, Newark, California, Sep. 1986, 6-page brochure.
- “Model 357, New Sloped Hood,” Peterbilt Motors Company, Denton, Texas, May 2002, 2-page brochure.
- “Model 357,” Peterbilt Motors Company, Denton, Texas, May 1994, 3-page brochure.
- “Model 357-115,” Peterbilt Motors Company, Denton, Texas, Mar. 2005, 2-page brochure.
- “Model 362,” Peterbilt Motors Company, Newark, California, 1985, 8-page brochure.
- “Model 375 Standard Specifications,” Peterbilt Motors Company, Newark, California, Sep. 1986, 6-page brochure.
- “Model 377A/E,” Peterbilt Motors Company, Denton, Texas, Aug. 1997, 2-page brochure.
- “Model 377A/E,” Peterbilt Motors Company, Denton, Texas, Jan. 1995, 6-page brochure.
- “Model 378,” Peterbilt Motors Company, Denton, Texas, Mar. 1998, 3-page brochure.
- “Model 379,” Peterbilt Motors Company, Denton, Texas, Apr. 2005, 2-page brochure.
- “Model 379,” Peterbilt Motors Company, Denton, Texas, Mar. 1996, 5-page brochure.
- “Model 385,” Peterbilt Motors Company, Denton, Texas, Oct. 1996, 5-page brochure.
- “Model 387,” Peterbilt Motors Company, Denton, Texas, Oct. 2002, 2-page brochure.
- “Paccar Engines, 2010 Medium Duty Engines,” Paccar Inc, Bellevue, Washington, 2010, 6-page brochure.
- “Paccar MX,” Paccar Inc, Bellevue, Washington, 2010, 4-page brochure.
- “Peterbilt Parts & Accessories,” Peterbilt Motors Company, Denton, Texas, catalog, as early as 2000, 52-page brochure.
- “Rest with Class,” Peterbilt Motors Company, Newark, California, Apr. 1978, 4-page brochure.
- “Studio Sleeper,” Kenworth Truck Company, Kirkland, Washington, 1993, 5-page brochure.
- “T170 Class 5,” Kenworth Truck Company, Kirkland, Washington, 2008, 4-page brochure.
- “T2000,” Kenworth Truck Company, Kirkland, Washington, 1999, 20-page brochure.
- “T2000,” Kenworth Truck Company, Kirkland, Washington, 2002, 20-page brochure.
- “T2000,” Kenworth Truck Company, Kirkland, Washington, 2005, 20-page brochure.
- “T270 Class 6 and T370 Class 7,” Kenworth Truck Company, Kirkland, Washington, 2008, 6-page brochure.
- “T270 Class 6 and T370 Class 7,” Kenworth Truck Company, Kirkland, Washington, 2009, 6-page brochure.
- “T270 Class 6 and T370 Class 7 Hybrid,” Kenworth Truck Company, Kirkland, Washington, 2009, 6-page brochure.
- “T300,” Kenworth Truck Company, Kirkland, Washington, 1994, 4-page brochure.
- “T300,” Kenworth Truck Company, Kirkland, Washington, 1997, 5-page brochure.
- “T300,” Kenworth Truck Company, Kirkland, Washington, 2001, 16-page brochure.
- “T300,” Kenworth Truck Company, Kirkland, Washington, 2005, 16-page brochure.
- “T400B and T450B,” Kenworth Truck Company, Kirkland, Washington, 1992, 10-page brochure.
- “T440,” Kenworth Truck Company, Kirkland, Washington, 2010, 2-page brochure.
- “T440,” Kenworth Truck Company, Kirkland, Washington, 2010, 6-page brochure.
- “T470,” Kenworth Truck Company, Kirkland, Washington, 2010, 6-page brochure.
- “T470H,” Kenworth Truck Company, Kirkland, Washington, 2009, 2-page brochure.
- “T600, Ten Years of Innovation,” Kenworth Truck Company, Kirkland, Washington, 1995, 6-page brochure.
- “T600,” Kenworth Truck Company, Kirkland, Washington, 1996, 7-page brochure.
- “T600,” Kenworth Truck Company, Kirkland, Washington, 2002, 28-page brochure.
- “T600,” Kenworth Truck Company, Kirkland, Washington, 2005, 24-page brochure.
- “T600A,” Kenworth Truck Company, Kirkland, Washington, 1985, 10-page brochure.
- “T660,” Kenworth Truck Company, Kirkland, Washington, 2007, 36-page brochure.
- “T660,” Kenworth Truck Company, Kirkland, Washington, 2009, 36-page brochure.
- “T700,” Kenworth Truck Company, Kirkland, Washington, 2010, 6-page brochure.
- “T800,” Kenworth Truck Company, Kirkland, Washington, 1996, 7-page brochure.
- “T800,” Kenworth Truck Company, Kirkland, Washington, 2002, 32-page brochure.
- “T800,” Kenworth Truck Company, Kirkland, Washington, 2003, 32-page brochure.
- “T800,” Kenworth Truck Company, Kirkland, Washington, 2005, 28-page brochure.
- “T800,” Kenworth Truck Company, Kirkland, Washington, 2009, 28-page brochure.
- “T800B,” Kenworth Truck Company, Kirkland, Washington, 1993, 8-page brochure.
- “The Working Class,” Peterbilt Motors Company, Newark, California, Sep. 1976, 6-page brochure.
- “The World’s Best,” Kenworth Truck Company, Kirkland, Washington, 1992, 12-page brochure.
- “Unibilt™ Cab Sleeper System,” Peterbilt Motors Company, Denton Texas, Aug. 1994, 6-page brochure.
- “W900,” Kenworth Truck Company, Kirkland, Washington, 1996, 7-page brochure.
- “W900,” Kenworth Truck Company, Kirkland, Washington, 2002, 32-page brochure.
- “W900,” Kenworth Truck Company, Kirkland, Washington, 2005, 28-page brochure.
- “W900,” Kenworth Truck Company, Kirkland, Washington, 2009, 28-page brochure.
- “W900L Aero Cab,” Kenworth Truck Company, Kirkland, Washington, 1994, 2-page brochure.

* cited by examiner

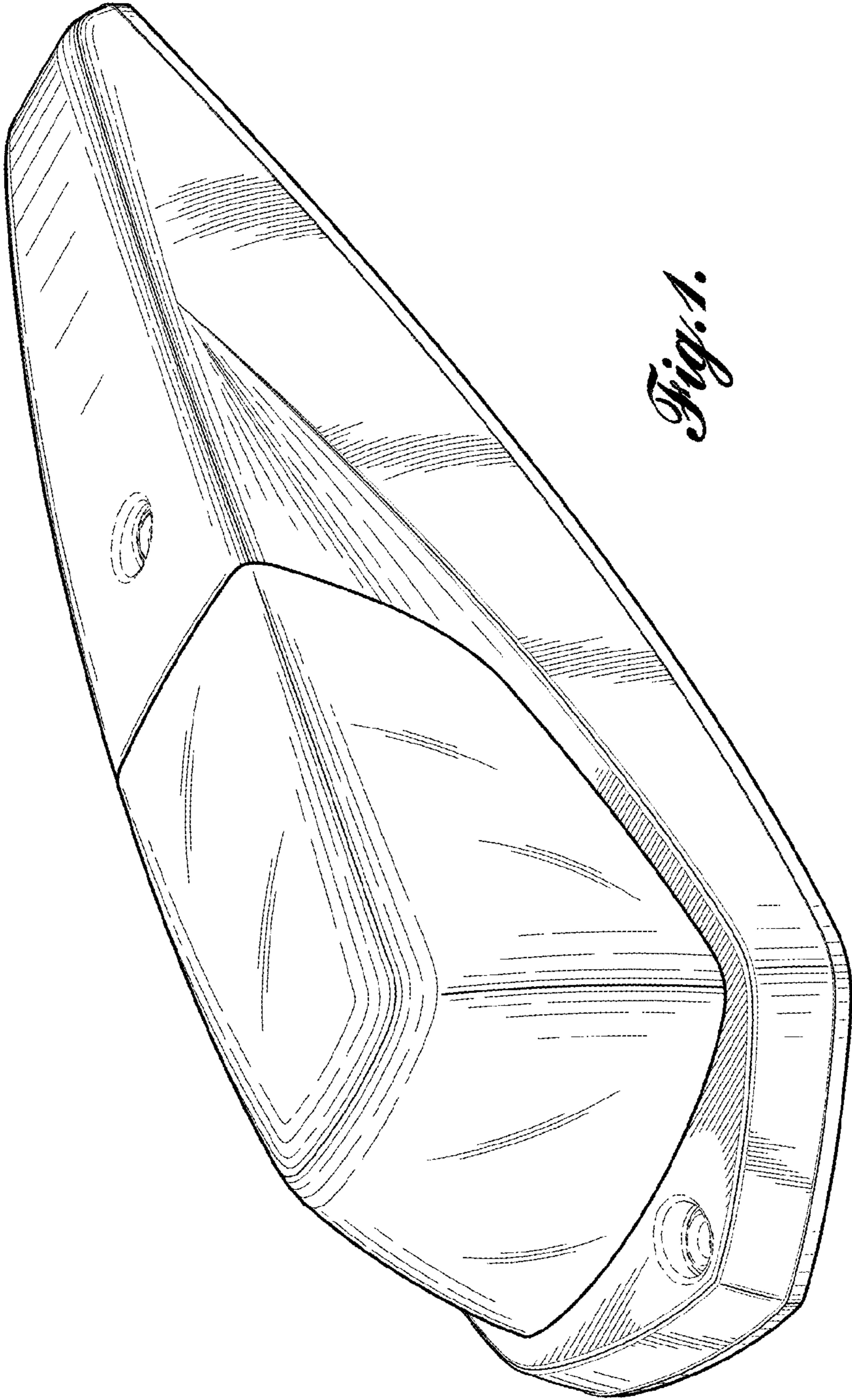

Fig. 1.

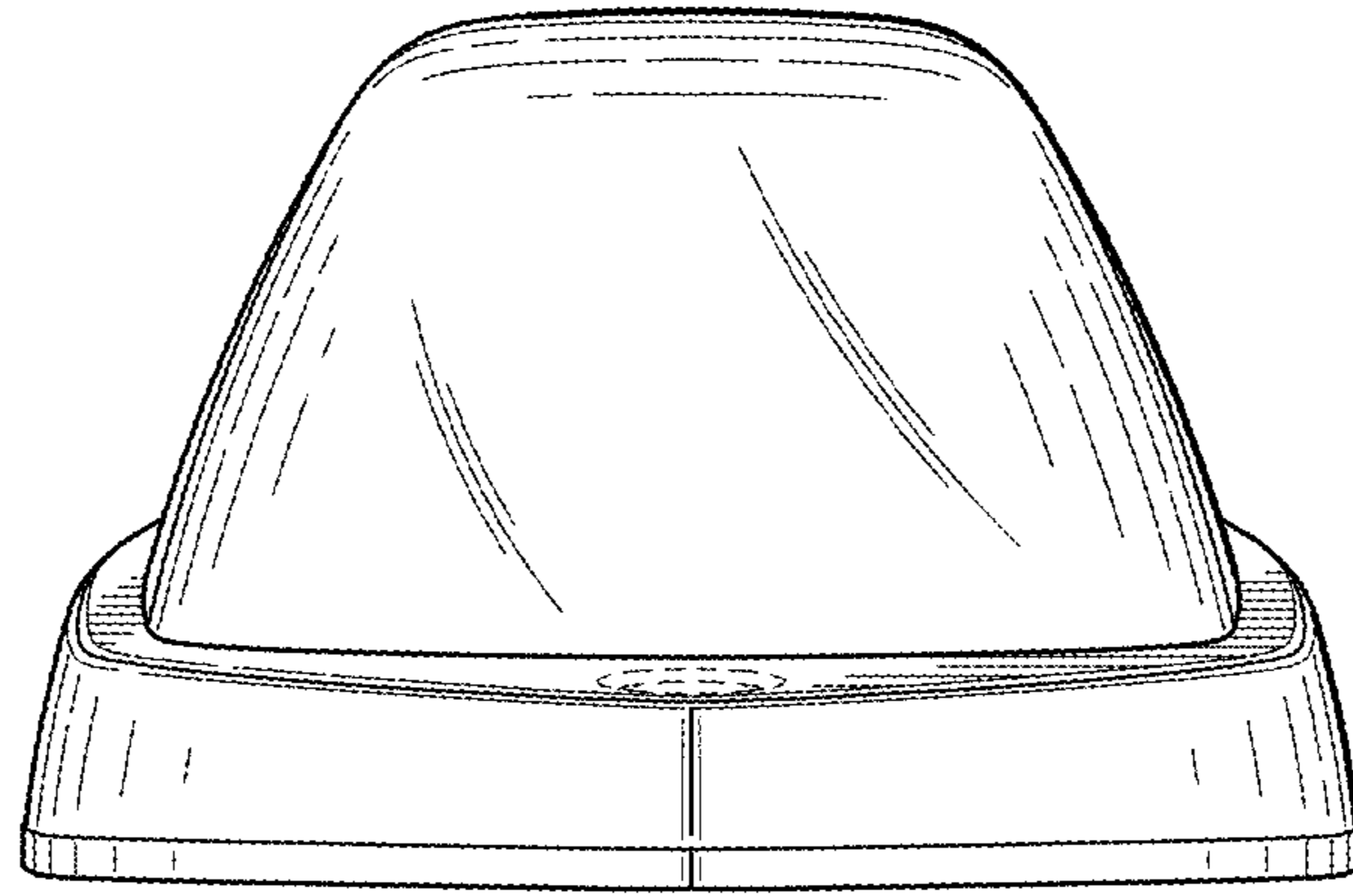

Fig. 2.

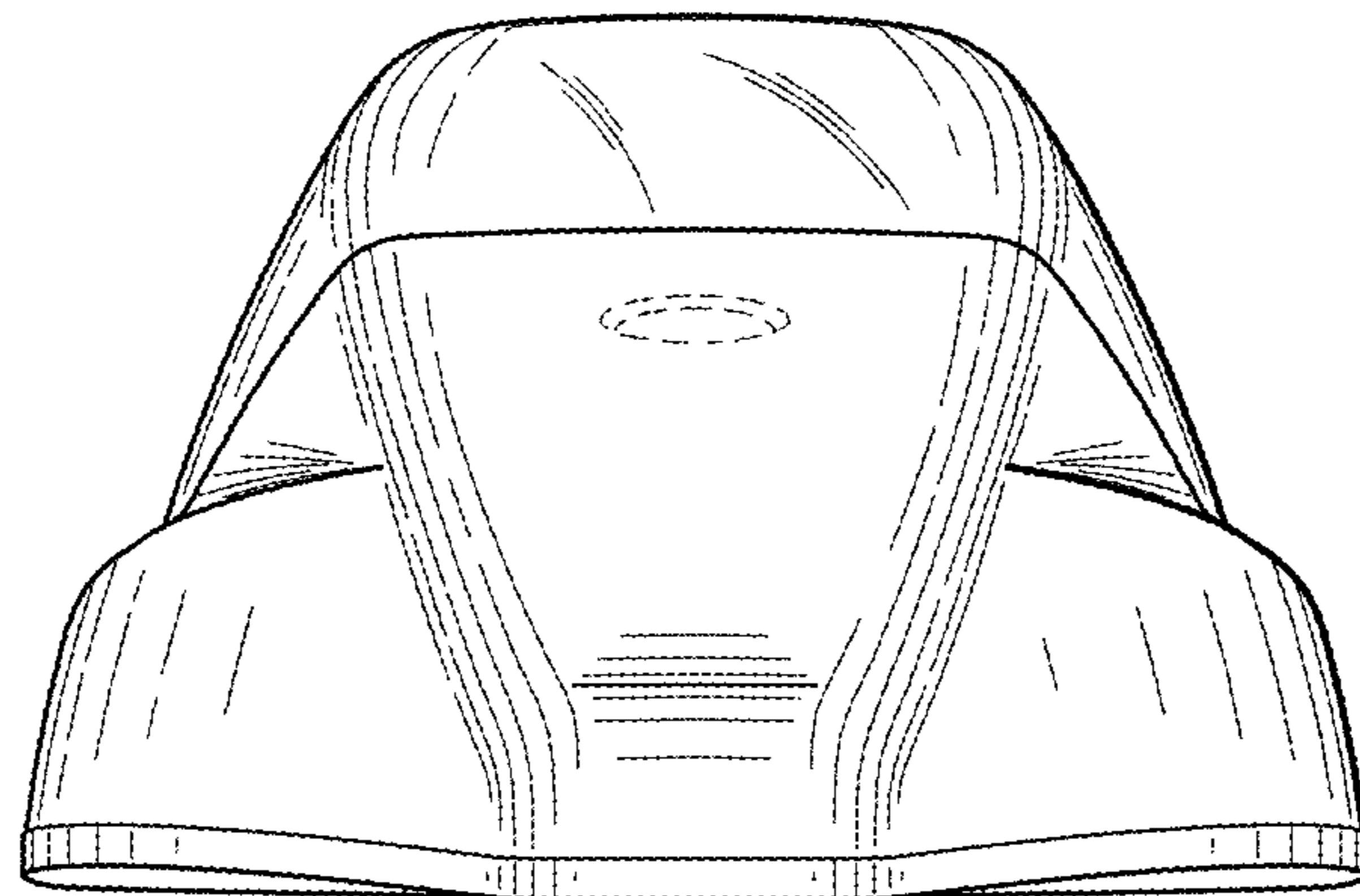

Fig. 3.

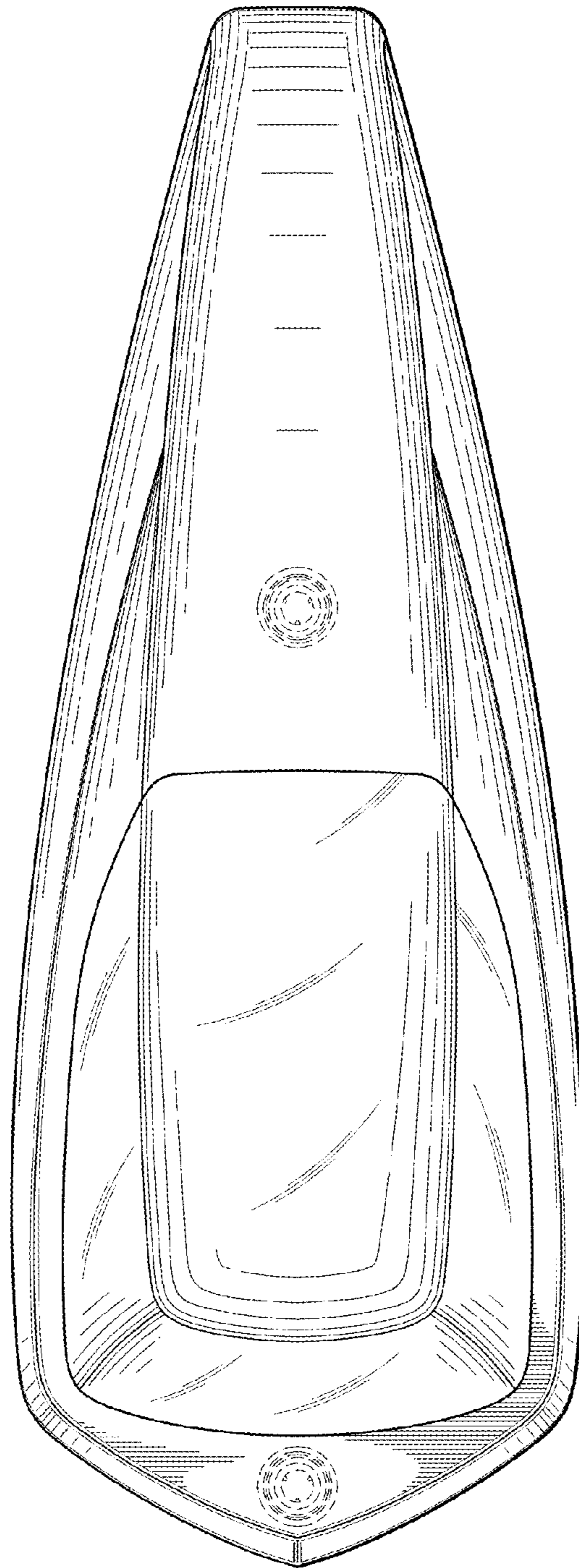

Fig. 4.

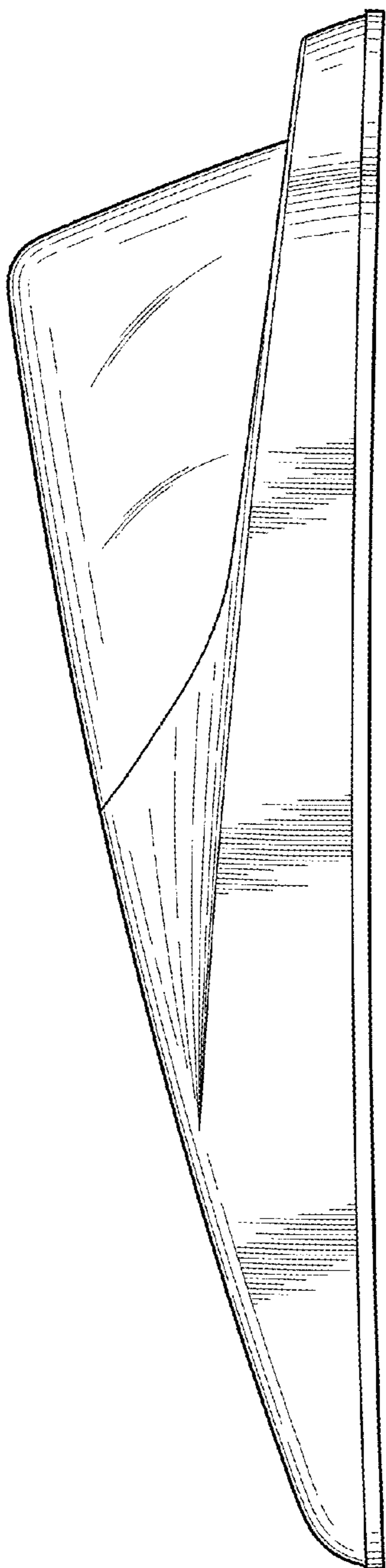

Fig. 5.

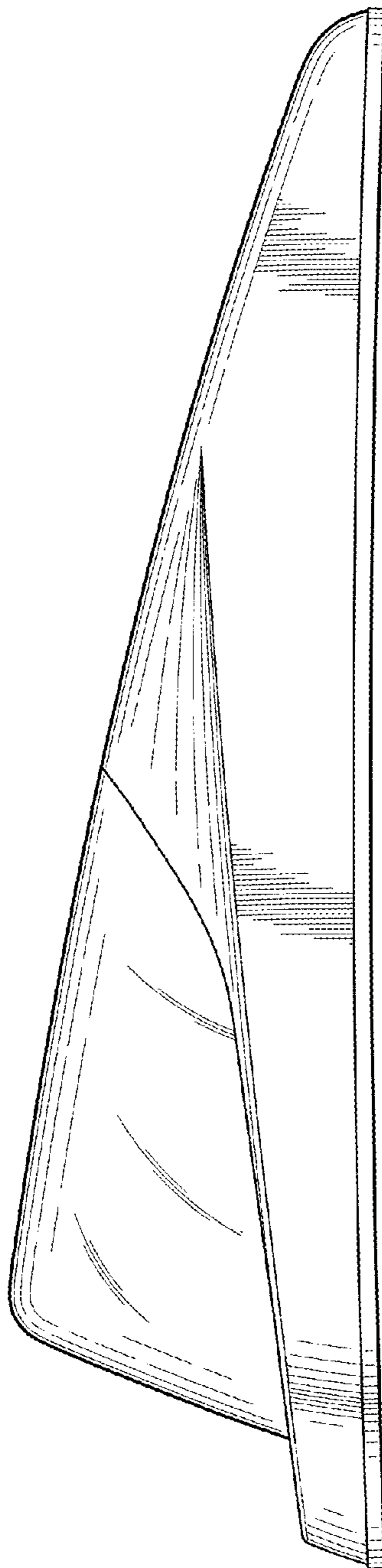

Fig. 6.