



US00D709188S

(12) **United States Design Patent**
Guala

(10) **Patent No.:** **US D709,188 S**

(45) **Date of Patent:** **** Jul. 15, 2014**

(54) **SPIKE FOR INFUSION / TRANSFUSION
MEDICAL DEVICES**

(75) Inventor: **Gianni Guala**, Turin (IT)

(73) Assignee: **Industrie Borla S.p.A.**, Moncalieri
(Turin) (IT)

(**) Term: **14 Years**

(21) Appl. No.: **29/394,656**

(22) Filed: **Jun. 20, 2011**

(30) **Foreign Application Priority Data**

Dec. 22, 2010 (EP) 001797531-0001
Dec. 22, 2010 (EP) 001797531-0002
Dec. 22, 2010 (EP) 001797531-0003
Dec. 22, 2010 (EP) 001797531-0004
Dec. 22, 2010 (EP) 001797531-0005

(51) **LOC (10) Cl.** **24-02**

(52) **U.S. Cl.**
USPC **D24/130**

(58) **Field of Classification Search**
USPC D24/127-131, 112-114, 133, 186;
606/181, 185; 604/264, 272, 115, 232,
604/187, 158, 164.08, 192, 263, 163, 181,
604/184, 1, 98, 227; 600/101, 139, 143;
128/200.24, 207.14, 207.15

See application file for complete search history.

(56) **References Cited**

U.S. PATENT DOCUMENTS

4,317,445 A * 3/1982 Robinson 604/168.01
D469,871 S * 2/2003 Sand D24/133
D614,296 S * 4/2010 Young D24/130
D615,648 S * 5/2010 Burke D24/130
7,744,567 B2 * 6/2010 Glowacki et al. 604/164.08
D619,251 S * 7/2010 Justiniano-Garcia
et al. D24/133
D620,107 S * 7/2010 Bartlett et al. D24/112
D620,591 S * 7/2010 Young D24/130
D625,003 S * 10/2010 Stephens D24/129
D625,004 S * 10/2010 McGrady et al. D24/129
D653,338 S * 1/2012 Mangeshikar D24/133
D663,832 S * 7/2012 Essinger et al. D24/112
D668,336 S * 10/2012 Yanagawa D24/130

* cited by examiner

Primary Examiner — David Muller

(74) *Attorney, Agent, or Firm* — Heslin Rothenberg Farley
& Mesiti P.C.; Victor A. Cardona

(57) **CLAIM**

The design for the spike for infusion/transfusion medical
devices, as shown and described.

DESCRIPTION

FIG. 1 is a top perspective view of a spike for infusion/
transfusion medical devices comprising the new design;
FIG. 2 is a side perspective view thereof;
FIG. 3 is top view thereof;
FIG. 4 is a right side view thereof;
FIG. 5 is front end view thereof; and,
FIG. 6 is a rear end thereof.

The broken lines in the figures are for illustration purposes
only and form no part of the claimed invention.

1 Claim, 6 Drawing Sheets

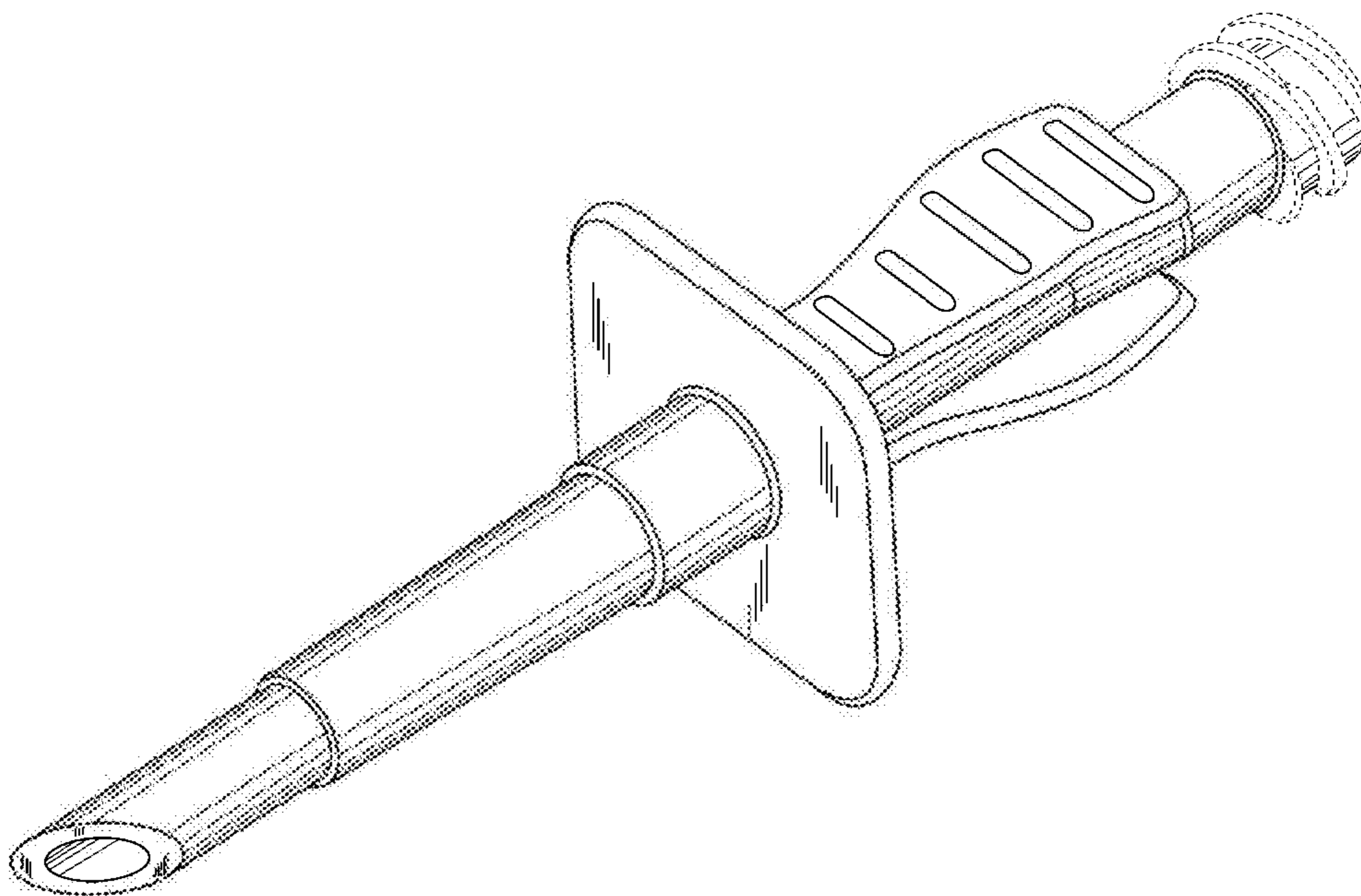

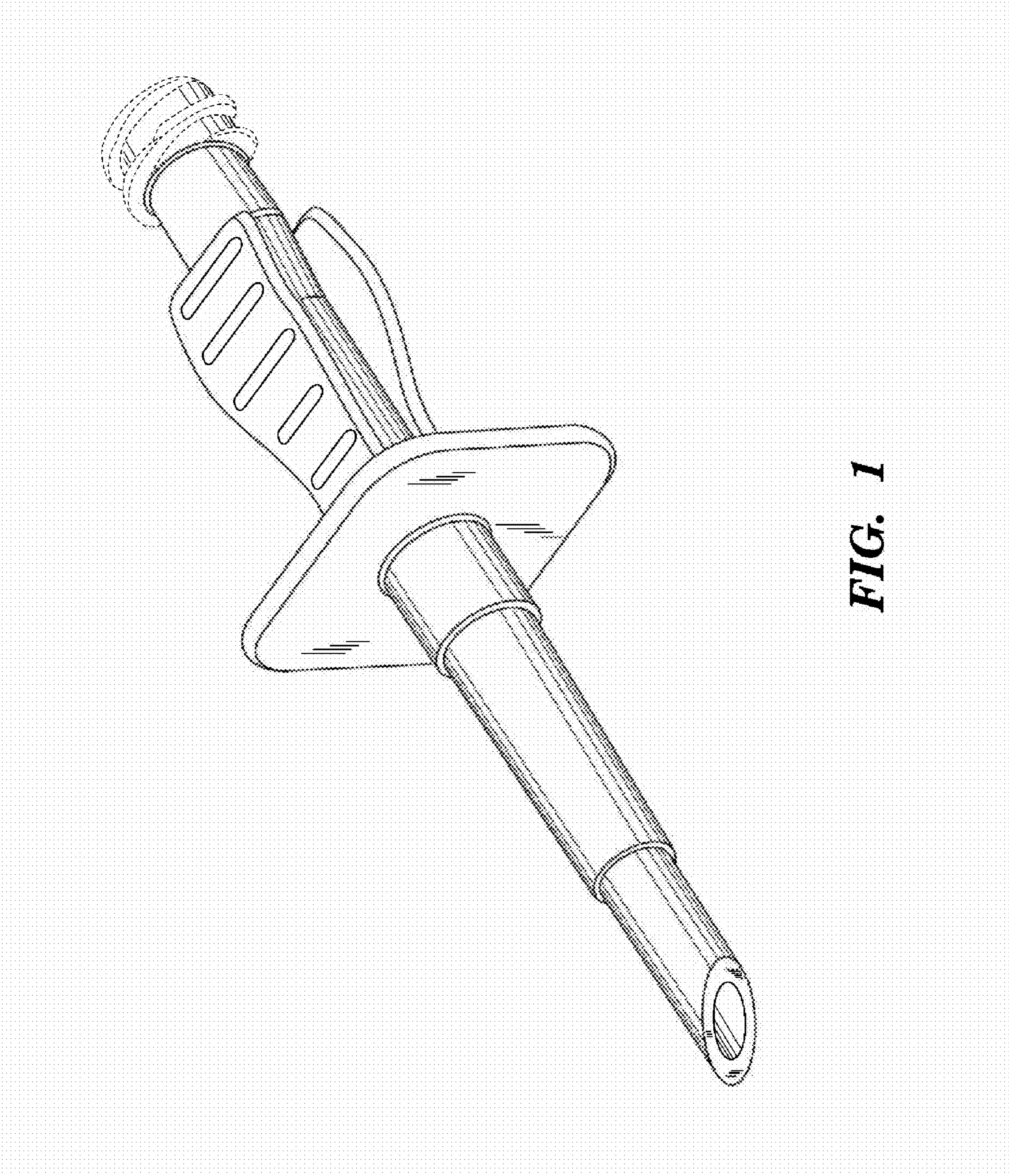

FIG. 1

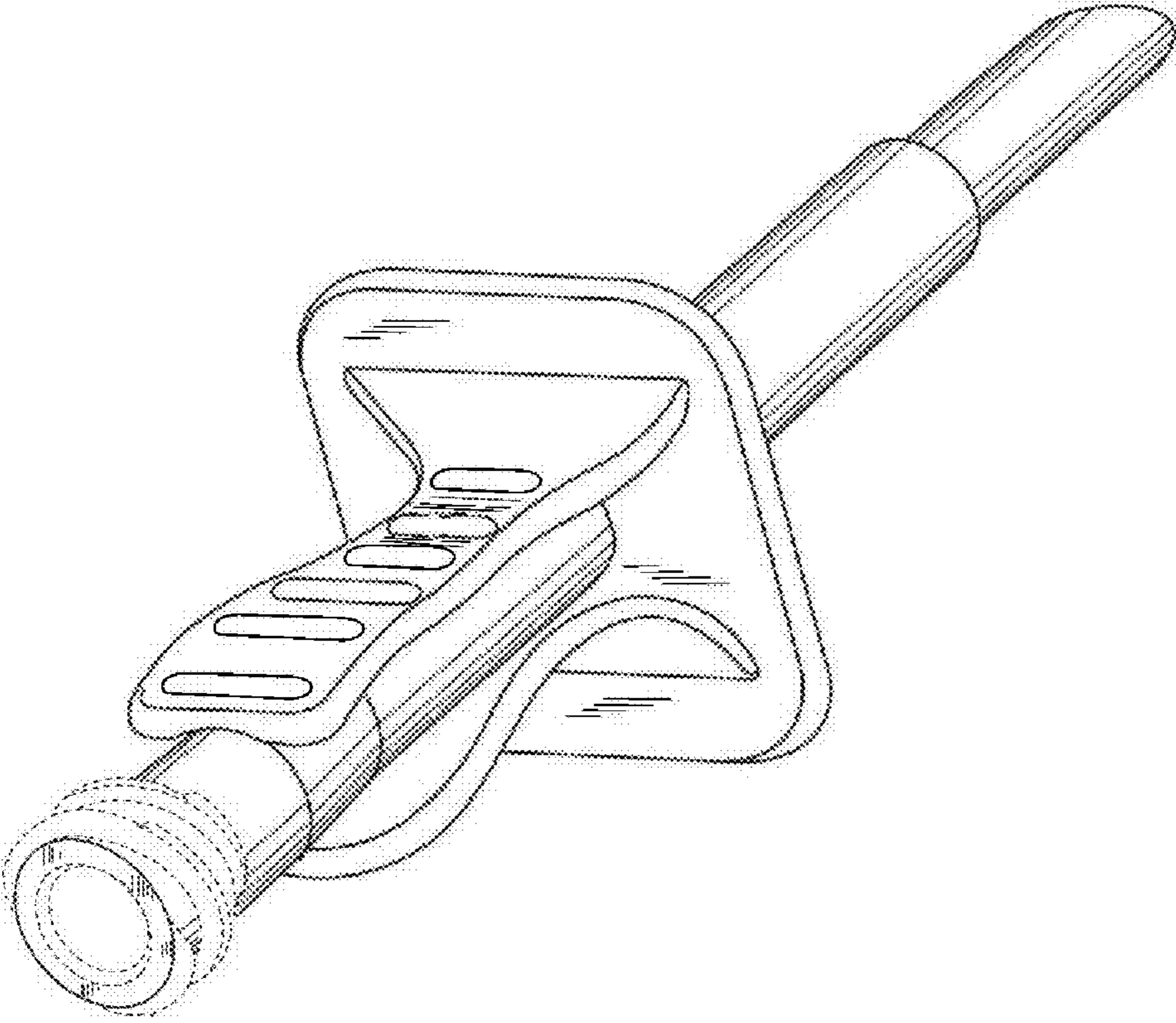

FIG. 2

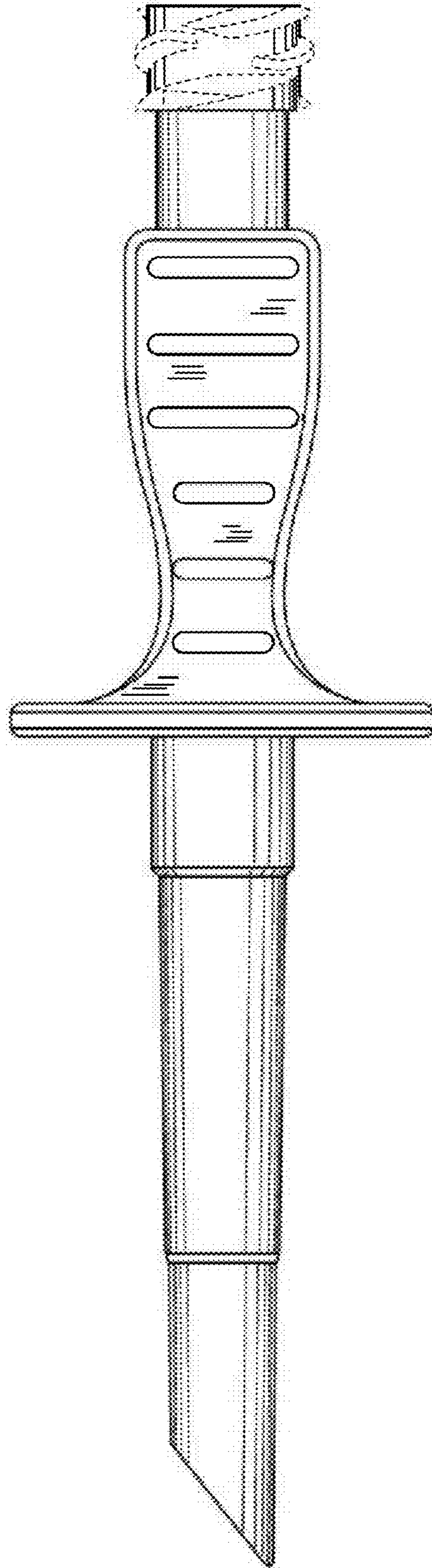

FIG. 3

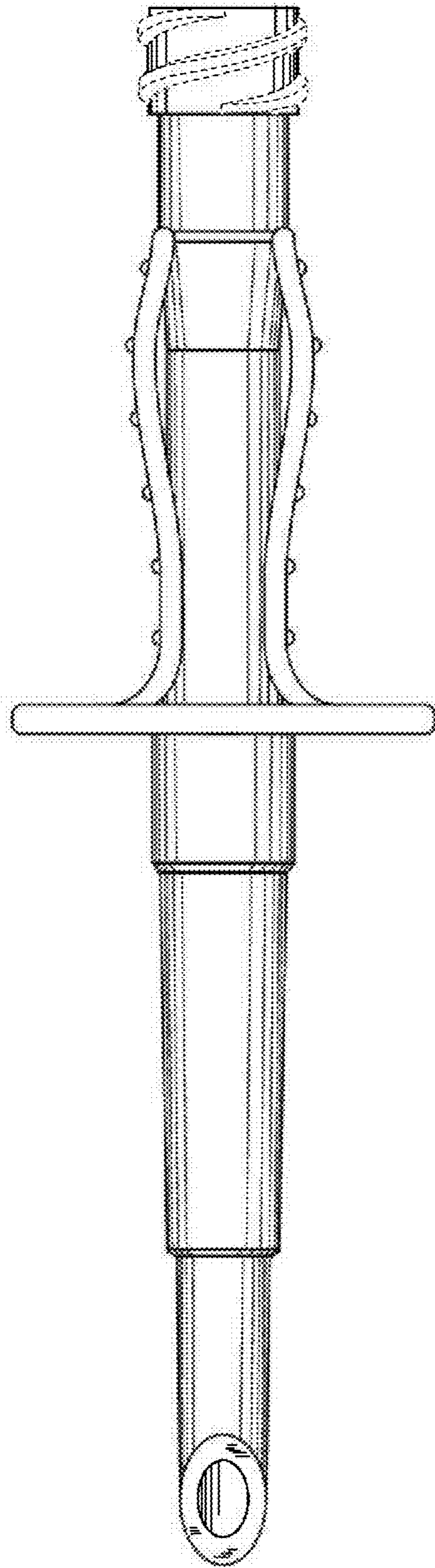

FIG. 4

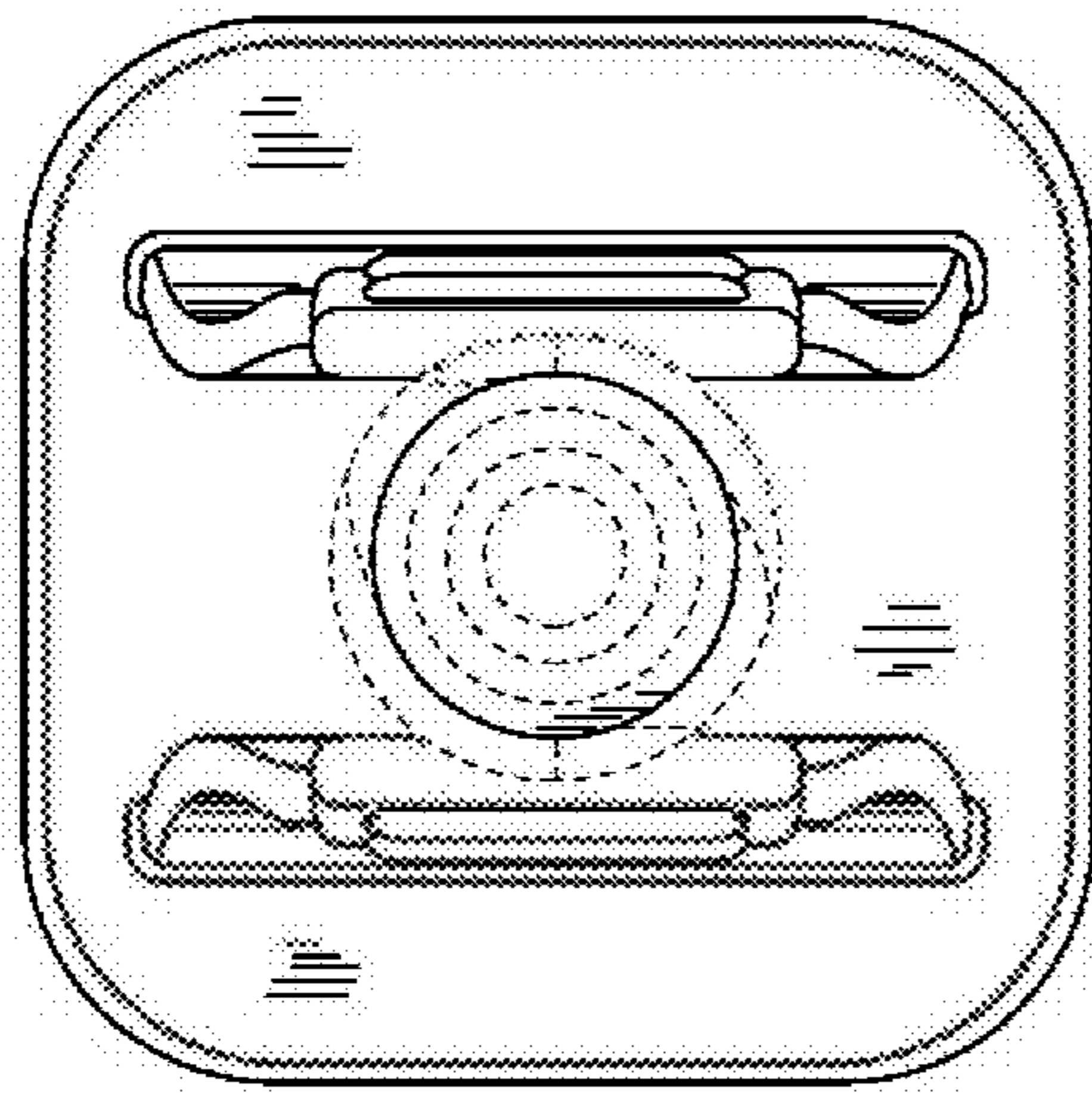

FIG. 5

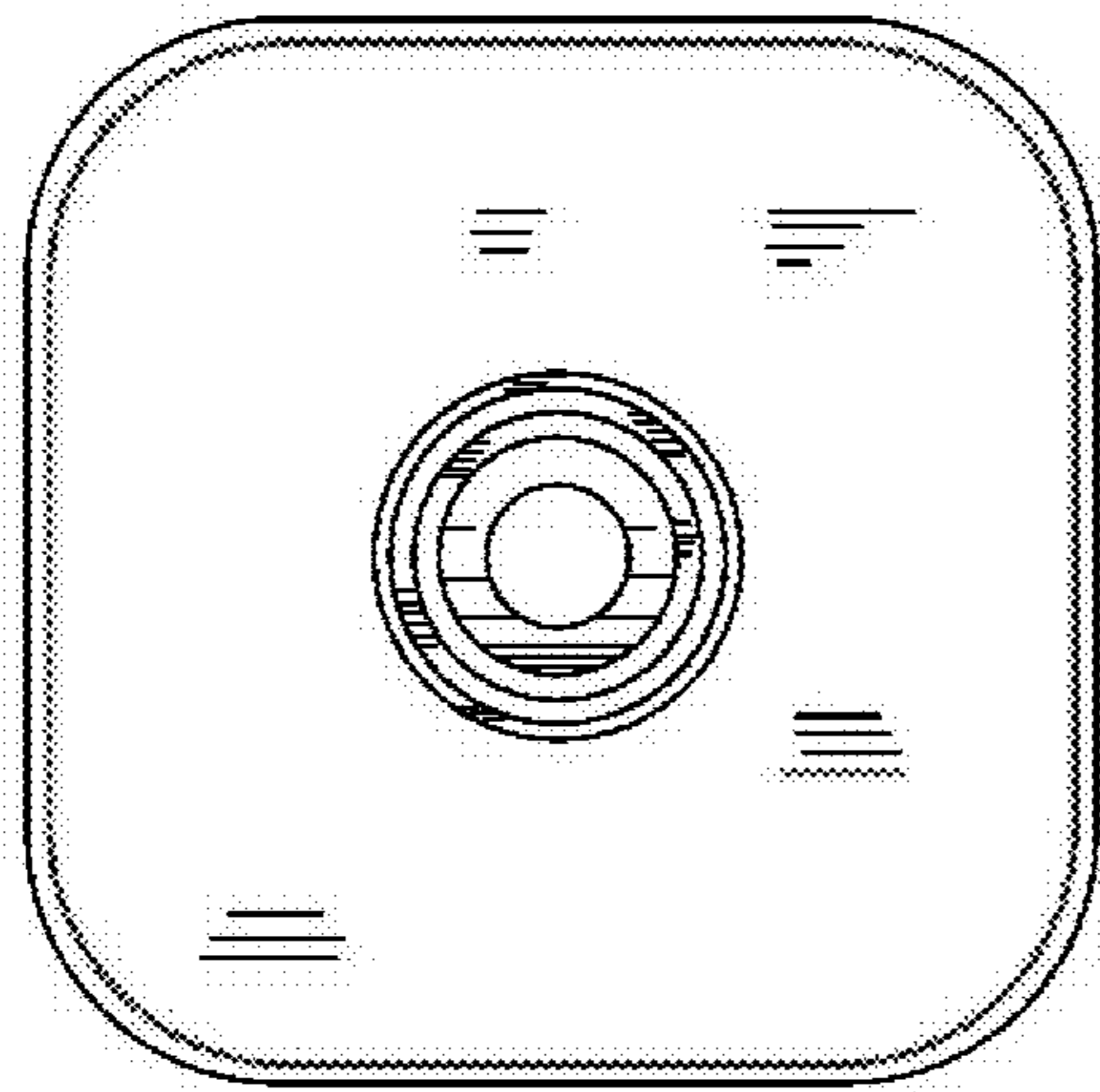

FIG. 6