



US00D709110S

(12) **United States Design Patent**  
**Morrison et al.**

(10) **Patent No.:** **US D709,110 S**  
(45) **Date of Patent:** **\*\* Jul. 15, 2014**

(54) **CUTTING INSERT**

OTHER PUBLICATIONS

(75) Inventors: **Lewis Ray Morrison**, Latrobe, PA (US);  
**Howard Murphy**, Northampton (GB);  
**Gianfranco Accardi**, Milan (IT); **Marco Procopio**, Milan (IT); **Andreas Lieber**, Zimdorf (DE); **Juan Seculi**, Nuremberg (DE); **Kumar Reddy Mylavaram**, **Nikhilesh**, Banganlore (IN)

PCT/US2010/055247: International Search Report dated Jul. 21, 2011 (10 pages).

(Continued)

*Primary Examiner* — Patricia Palasik  
(74) *Attorney, Agent, or Firm* — Larry R. Meenan, Esq.

(73) Assignee: **Kennametal Inc.**, Latrobe, PA (US)

(57) **CLAIM**  
The ornamental design for a cutting insert, as shown and described.

(\*\*) Term: **14 Years**

(21) Appl. No.: **29/426,083**

**DESCRIPTION**

(22) Filed: **Jun. 29, 2012**

**Related U.S. Application Data**

(63) Continuation-in-part of application No. 13/454,660, filed on Apr. 24, 2012.

(51) **LOC (10) Cl.** ..... **15-09**

(52) **U.S. Cl.**  
USPC ..... **D15/139**

(58) **Field of Classification Search**  
USPC ..... D15/138, 139; 407/42, 112-119  
See application file for complete search history.

(56) **References Cited**

**U.S. PATENT DOCUMENTS**

1,460,030 A 6/1923 Mattson  
1,838,520 A 12/1931 Archer  
2,630,725 A 3/1953 Black

(Continued)

**FOREIGN PATENT DOCUMENTS**

CN 1623709 A 6/2005  
DE 3321184 A1 12/1984

(Continued)

FIG. 1 is a top view of the cutting insert in accordance with the subject invention;  
FIG. 2 is a perspective view of the cutting insert illustrated in FIG. 1;  
FIG. 3 is perspective view of the cutting insert illustrated in FIG. 1 but rotated 180 degrees from the perspective view illustrated in FIG. 2;  
FIG. 4 is a bottom view of the cutting insert illustrated in FIG. 1;  
FIG. 5 is a perspective view of the bottom of the cutting insert illustrated in FIG. 4;  
FIG. 6 is a perspective view of the cutting insert illustrated in FIG. 4 but rotated 180 degrees from that perspective view illustrated in FIG. 5;  
FIG. 7 is a side view of the cutting insert along arrows 7-7 in FIG. 1;  
FIG. 8 is a side view of the cutting insert along arrows 8-8 in FIG. 1;  
FIG. 9 is a side view of the cutting insert along arrows 9-9 in FIG. 1; and,  
FIG. 10 is a side view of the cutting insert along arrows 10-10 in FIG. 1.

The broken lines of FIGS. 1-6 are environmental only and not part of the claimed design.

**1 Claim, 4 Drawing Sheets**

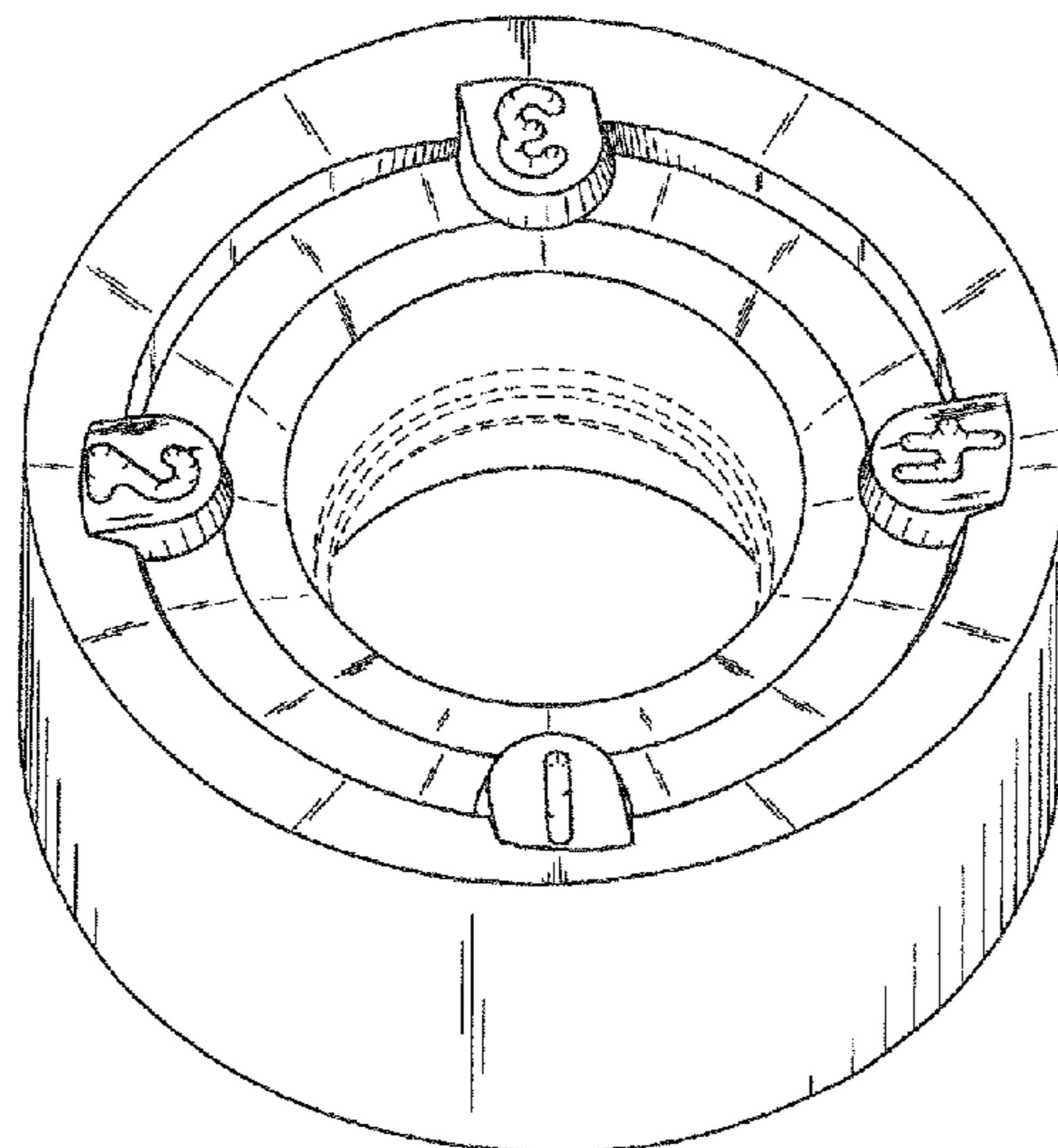

(56)

References Cited

U.S. PATENT DOCUMENTS

3,213,716 A 10/1965 Getts  
 3,408,722 A 11/1968 Berry, Jr. et al.  
 3,629,919 A 12/1971 Trevarrow, Jr.  
 3,831,237 A 8/1974 Gunsalus  
 3,842,470 A 10/1974 Hertel  
 3,875,663 A 4/1975 Gustafson  
 3,946,474 A 3/1976 Hahn et al.  
 3,996,651 A 12/1976 Heaton et al.  
 4,189,264 A 2/1980 Kraemer  
 4,202,650 A 5/1980 Erickson  
 4,304,509 A 12/1981 Mori  
 4,315,706 A 2/1982 Erkfritz  
 4,632,593 A 12/1986 Stashko  
 4,636,116 A 1/1987 Shikata  
 4,812,087 A 3/1989 Stashko  
 4,880,338 A 11/1989 Stashko  
 4,915,548 A 4/1990 Fouquer et al.  
 4,934,844 A 6/1990 Orii  
 5,046,899 A 9/1991 Nishi  
 5,147,158 A 9/1992 Rivière  
 5,199,828 A 4/1993 Forsberg et al.  
 5,236,288 A 8/1993 Flueckiger  
 5,275,633 A 1/1994 Johansson et al.  
 5,346,336 A 9/1994 Rescigno  
 D363,727 S 10/1995 DeRoche  
 5,478,175 A 12/1995 Kraemer  
 5,542,794 A 8/1996 Smith et al.  
 5,558,142 A 9/1996 Ehrle et al.  
 5,658,100 A 8/1997 Deiss et al.  
 5,702,210 A 12/1997 Boianjiu  
 D390,578 S \* 2/1998 Satran et al. .... D15/139  
 5,716,167 A 2/1998 Siddle et al.  
 5,733,073 A 3/1998 Zitzlaff et al.  
 5,772,365 A 6/1998 Vogel et al.  
 5,772,366 A 6/1998 Wiman et al.  
 5,810,518 A 9/1998 Wiman et al.  
 5,827,016 A 10/1998 Strand  
 5,836,723 A 11/1998 Von Haas et al.  
 5,846,032 A 12/1998 Murakami  
 5,888,029 A 3/1999 Boianjiu  
 5,931,613 A 8/1999 Larsson  
 5,934,844 A \* 8/1999 Woolley ..... 407/114  
 D416,917 S 11/1999 Xie et al.  
 6,050,751 A 4/2000 Hellstrom  
 6,053,671 A 4/2000 Stedt et al.  
 6,126,366 A 10/2000 Lundblad  
 6,152,658 A 11/2000 Satran et al.  
 6,158,928 A 12/2000 Hecht  
 6,164,878 A 12/2000 Satran et al.  
 6,168,356 B1 1/2001 Sjoo et al.  
 D442,193 S \* 5/2001 Isaksson ..... D15/139  
 6,224,300 B1 5/2001 Baxivanelis et al.  
 6,234,724 B1 5/2001 Satran et al.  
 6,238,133 B1 5/2001 DeRoche et al.  
 6,343,898 B1 2/2002 Sjoo et al.  
 6,508,612 B1 1/2003 Baca  
 6,543,970 B1 4/2003 Qvarth et al.  
 6,579,042 B1 6/2003 Shiraiwa  
 D477,004 S 7/2003 Arvidsson  
 6,607,335 B2 8/2003 Morgulis  
 6,840,716 B2 1/2005 Morgulis et al.  
 6,926,472 B2 8/2005 Arvidsson  
 6,929,428 B1 8/2005 Wermeister et al.  
 6,948,889 B2 9/2005 Arvidsson  
 7,021,871 B2 4/2006 Arvidsson et al.  
 D523,039 S 6/2006 Niebauer et al.  
 7,070,363 B2 7/2006 Long, II et al.  
 7,073,987 B2 7/2006 Hecht  
 7,121,771 B2 10/2006 Englund  
 7,156,006 B2 1/2007 Hyatt et al.  
 7,168,895 B2 1/2007 Koskinen et al.  
 7,300,232 B2 11/2007 Wiman et al.  
 7,306,409 B2 12/2007 Stabel et al.  
 7,325,471 B2 2/2008 Massa et al.  
 7,381,015 B2 6/2008 Jonsson

7,387,474 B2 6/2008 Edler et al.  
 7,390,149 B2 6/2008 Wihlborg  
 7,407,348 B2 8/2008 Sjogren et al.  
 7,458,753 B1 12/2008 Niebauer et al.  
 7,476,061 B2 1/2009 Edler  
 7,513,717 B2 4/2009 Engström et al.  
 7,530,769 B2 5/2009 Kress et al.  
 7,578,639 B2 8/2009 Wiman et al.  
 7,604,441 B2 10/2009 Bhagath  
 7,607,867 B2 10/2009 Benson  
 7,607,868 B2 10/2009 Noggle  
 7,722,297 B2 5/2010 Dufour et al.  
 7,785,045 B2 8/2010 Viol  
 D638,452 S \* 5/2011 Morrison et al. .... D15/139  
 D640,717 S \* 6/2011 Morrison et al. .... D15/139  
 7,959,383 B2 6/2011 Choi et al.  
 8,096,735 B2 1/2012 Sladek et al.  
 D658,218 S \* 4/2012 Morrison et al. .... D15/139  
 8,147,171 B2 4/2012 Dufour et al.  
 D673,194 S \* 12/2012 Kovac et al. .... D15/139  
 8,430,607 B2 4/2013 Jansson  
 2003/0086766 A1 5/2003 Andras  
 2003/0219319 A1 11/2003 Arvidsson  
 2004/0028486 A1 2/2004 Englund  
 2005/0019110 A1 1/2005 Astrakhan  
 2005/0019113 A1 1/2005 Wermeister  
 2005/0084342 A1 4/2005 Festeau et al.  
 2005/0152754 A1 7/2005 Wiman et al.  
 2005/0244233 A1 11/2005 Jonsson  
 2006/0088390 A1 4/2006 Wallstrom et al.  
 2006/0147280 A1 7/2006 Sjogren et al.  
 2006/0245837 A1 11/2006 Dufour et al.  
 2006/0269374 A1 11/2006 Dufour et al.  
 2007/0009334 A1 1/2007 Edler  
 2007/0071559 A1 3/2007 Koskinen  
 2007/0122242 A1 5/2007 Englund et al.  
 2007/0189862 A1 8/2007 Viol  
 2007/0245535 A1 10/2007 Noggle  
 2008/0056831 A1 3/2008 Wiman et al.  
 2008/0181731 A1 7/2008 Wallstrom et al.  
 2008/0193233 A1 8/2008 Park  
 2008/0317558 A1 12/2008 Niebauer et al.  
 2009/0052998 A1 2/2009 Sladek et al.  
 2009/0097929 A1 4/2009 Festeau et al.  
 2009/0290946 A1 11/2009 Zastrozynski  
 2010/0034602 A1 2/2010 Sung et al.  
 2010/0061816 A1 3/2010 Koerner et al.  
 2010/0158620 A1 6/2010 Spitzenberger et al.  
 2010/0183386 A1 7/2010 Heinloth et al.  
 2010/0239379 A1 9/2010 Choi et al.  
 2010/0247257 A1 9/2010 Paul et al.  
 2011/0103905 A1 5/2011 Morrison et al.  
 2011/0116878 A1 \* 5/2011 Ebert et al. .... 407/114  
 2011/0164934 A1 \* 7/2011 Chen et al. .... 407/114  
 2012/0003493 A1 1/2012 Schon et al.  
 2012/0251250 A1 10/2012 Morrison et al.

FOREIGN PATENT DOCUMENTS

DE 4244316 A1 6/1994  
 DE 19506944 A1 8/1995  
 DE 69901623 T2 11/2002  
 DE 102005025815 A1 12/2006  
 DE 102006011581 A1 9/2007  
 DE 102008037915 B3 8/2009  
 DE 102009049088 A1 4/2011  
 EP 300172 A2 1/1989  
 EP 0599393 A1 6/1994  
 EP 0698437 A1 2/1996  
 EP 0730926 A1 9/1996  
 EP 1468770 A1 10/2004  
 EP 1535681 A1 6/2005  
 JP 63142944 A 6/1988  
 JP 7299633 A 11/1995  
 JP 1119817 A 4/1999  
 JP 11245105 A 9/1999  
 JP 1310808 A 11/1999  
 KR 1020060019993 A 3/2006  
 SE 533249 A1 7/2010



(56)

**References Cited**

FOREIGN PATENT DOCUMENTS

WO	9415741	A1	7/1994
WO	0128722	A1	4/2001
WO	2005068116	A1	7/2005
WO	2007037733	A1	4/2007
WO	2007104275	A1	9/2007
WO	2007127109	A2	11/2007

WO	2008029964	A1	3/2008
WO	2010017859	A1	2/2010

OTHER PUBLICATIONS

English Machine Translation of DE 10 2005 025 815.  
English Machine Translation of DE 10 2006 011 581.

\* cited by examiner

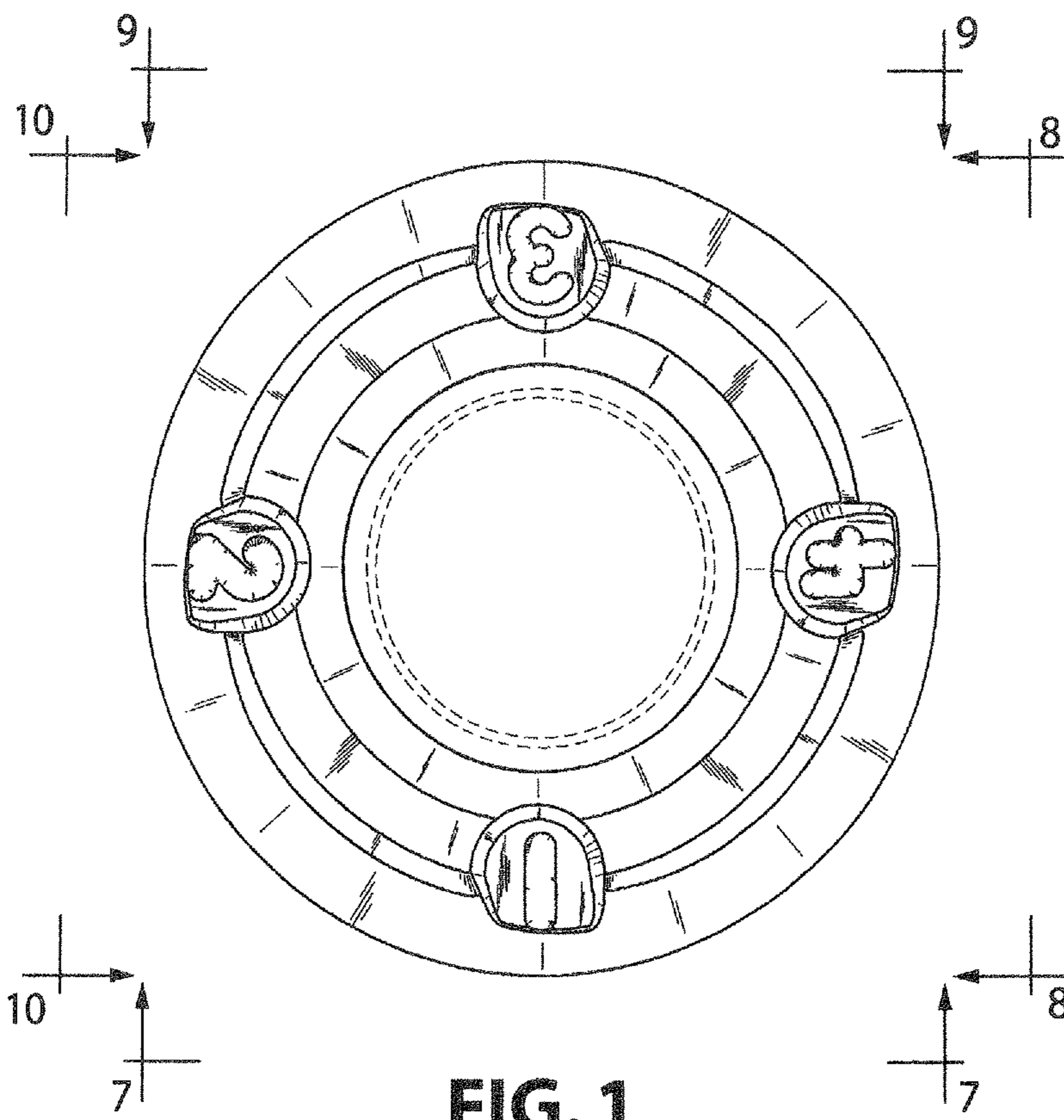

**FIG. 1**

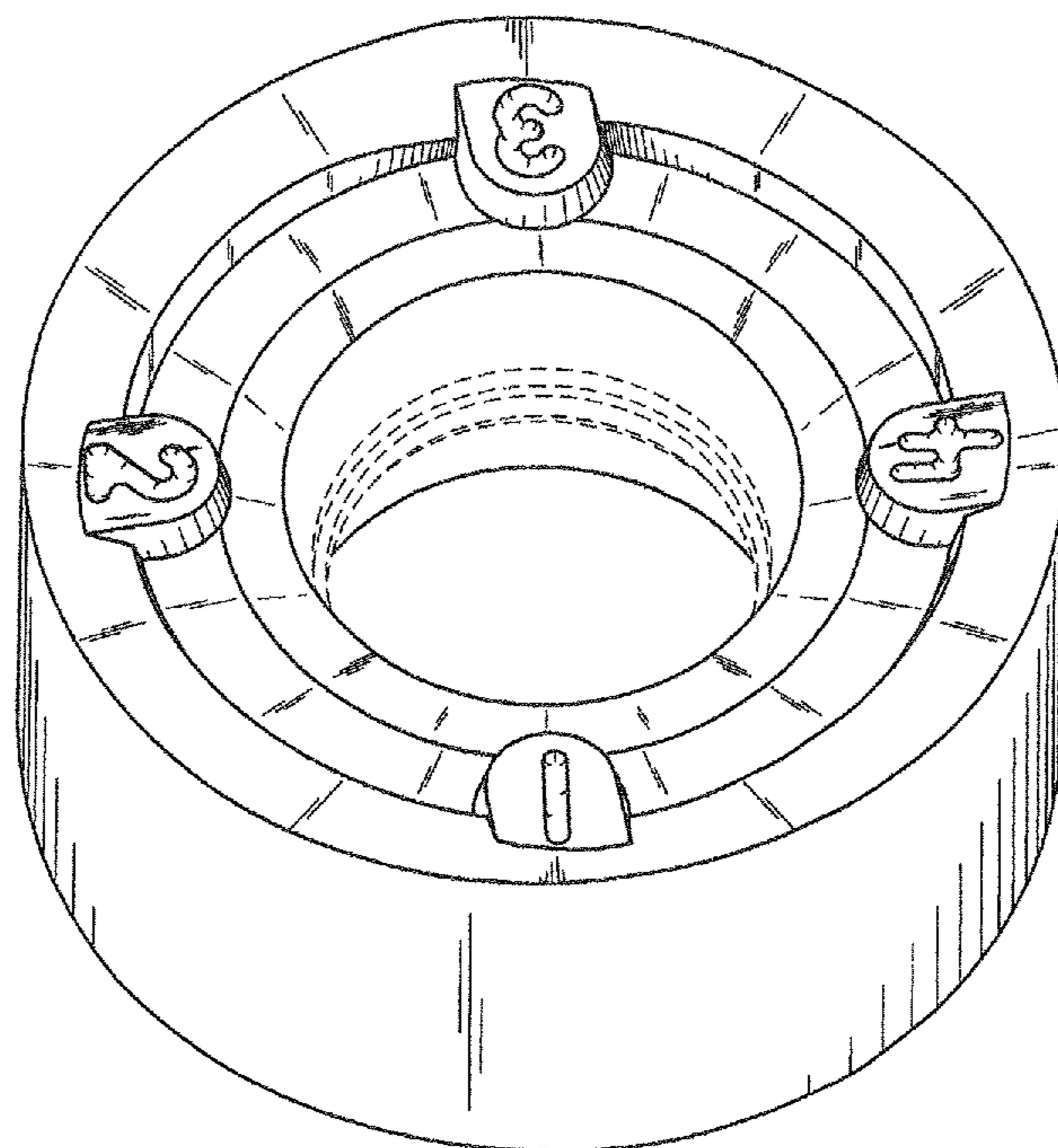

**FIG. 2**

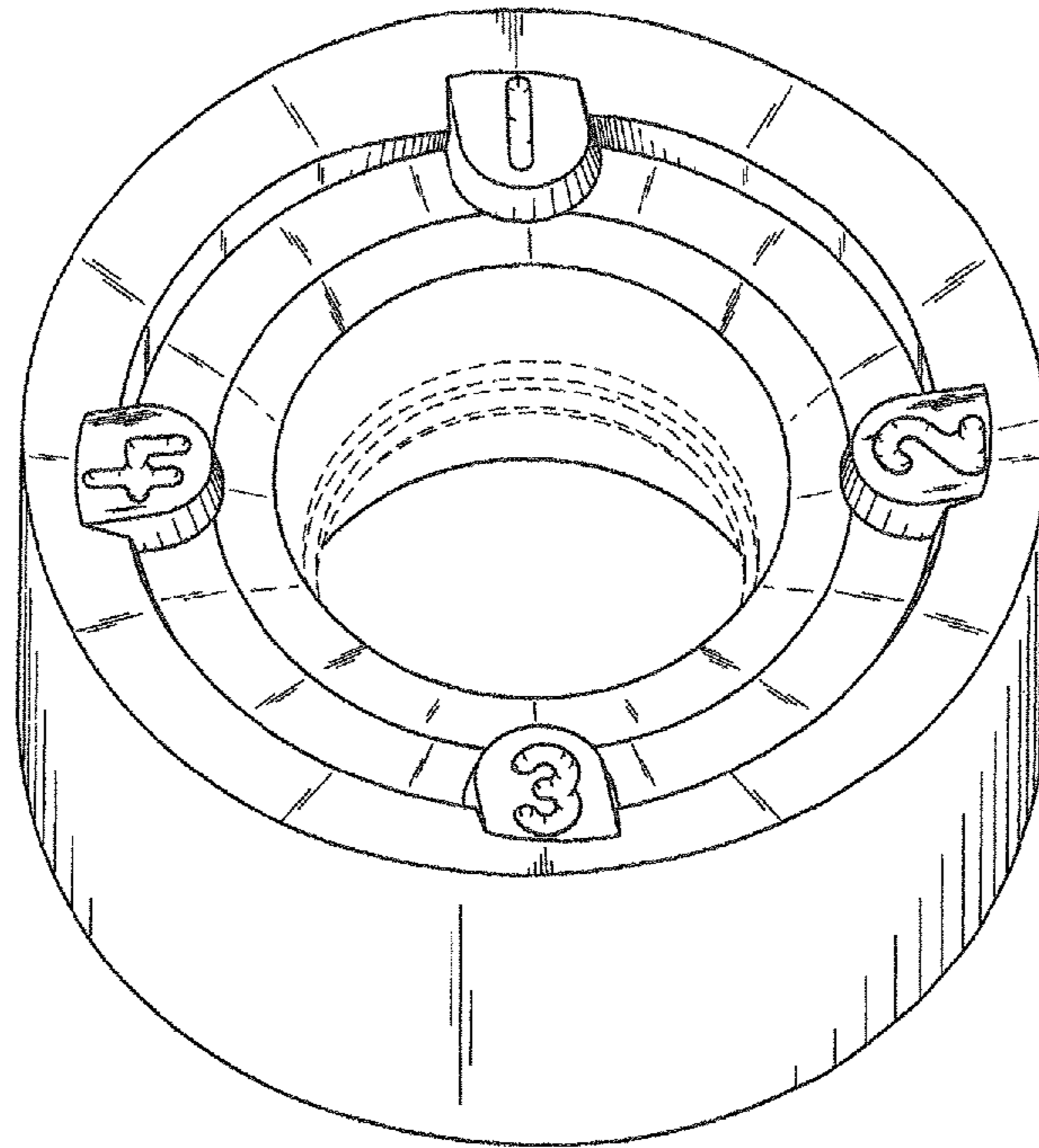

**FIG. 3**

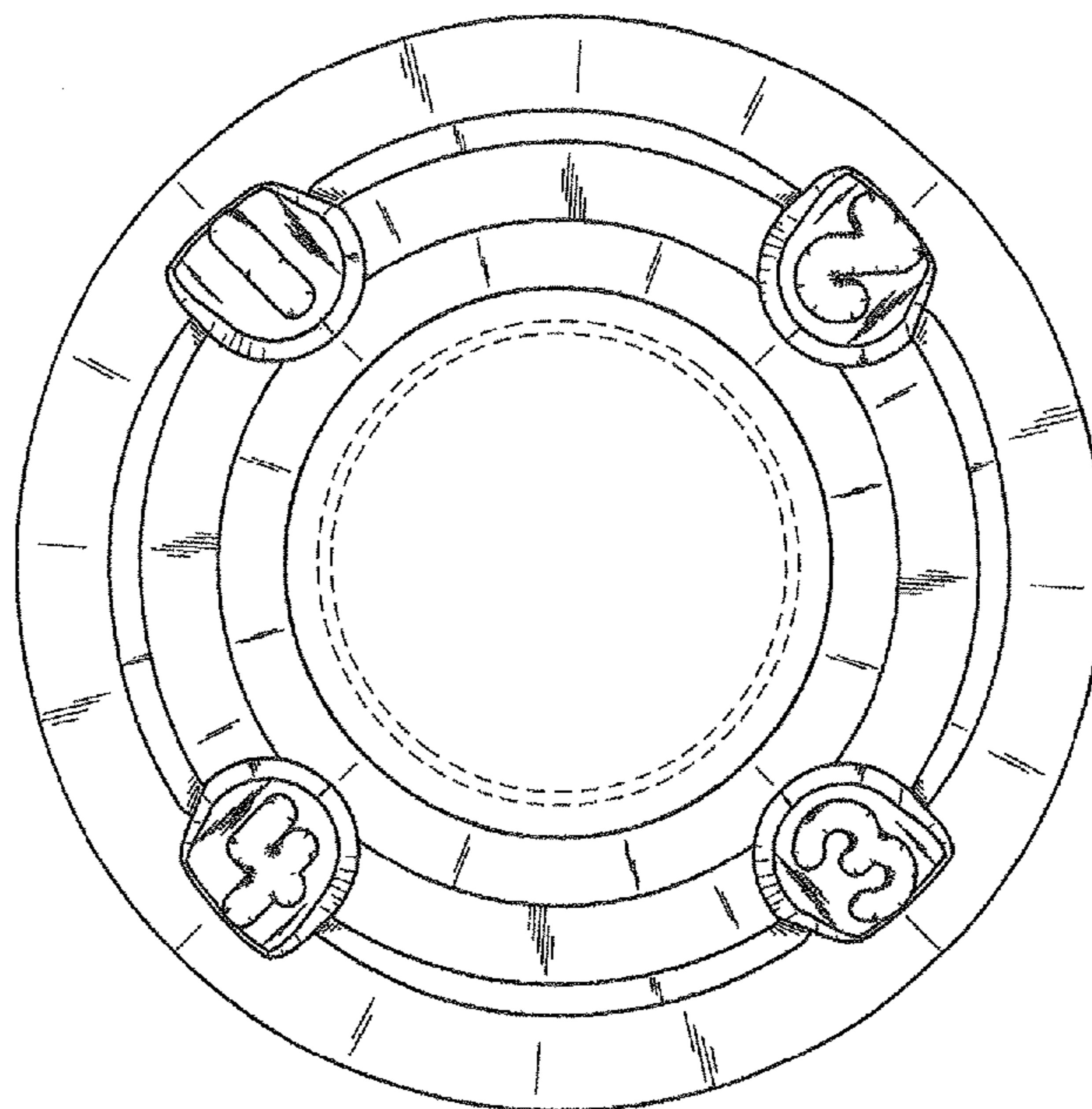

**FIG. 4**

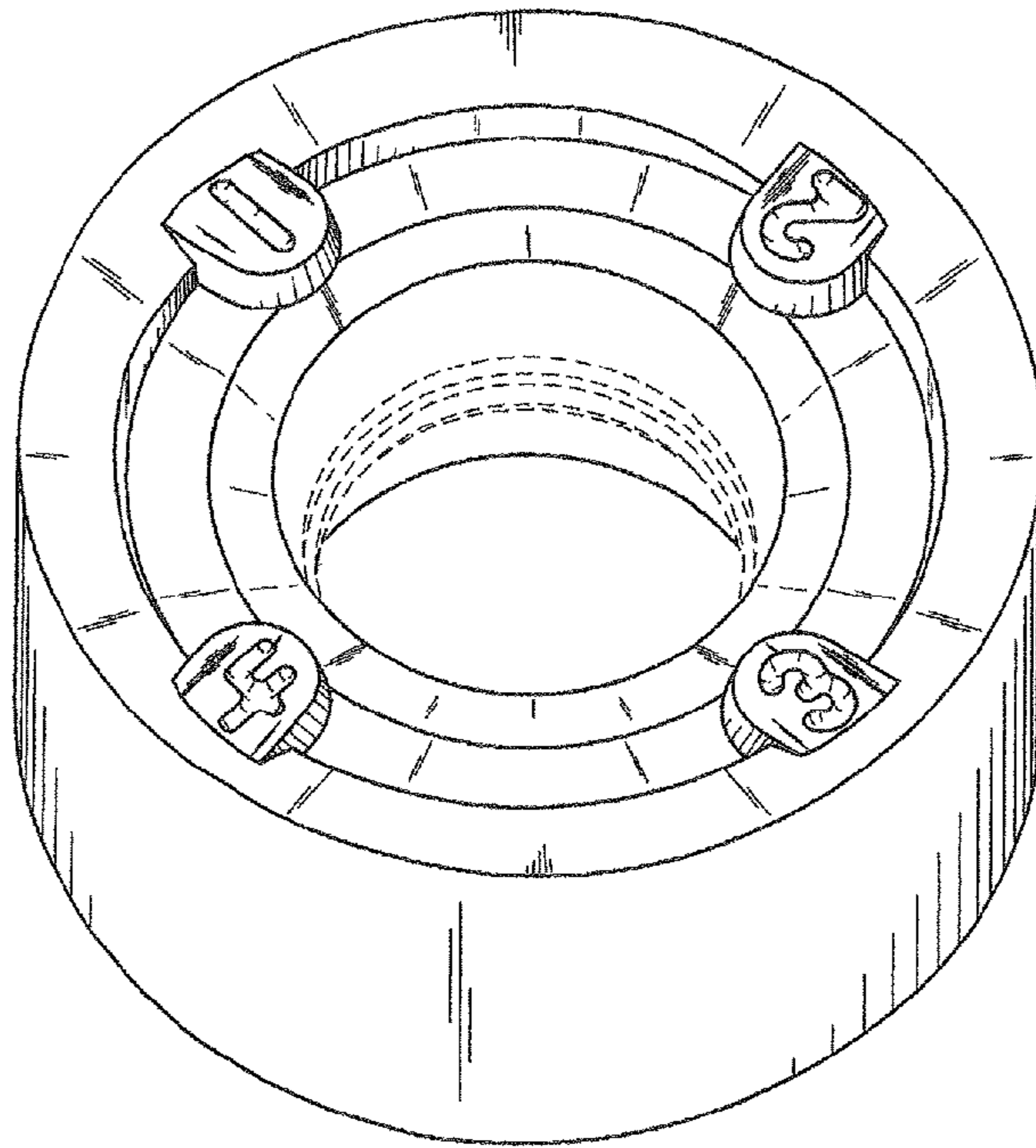

**FIG. 5**

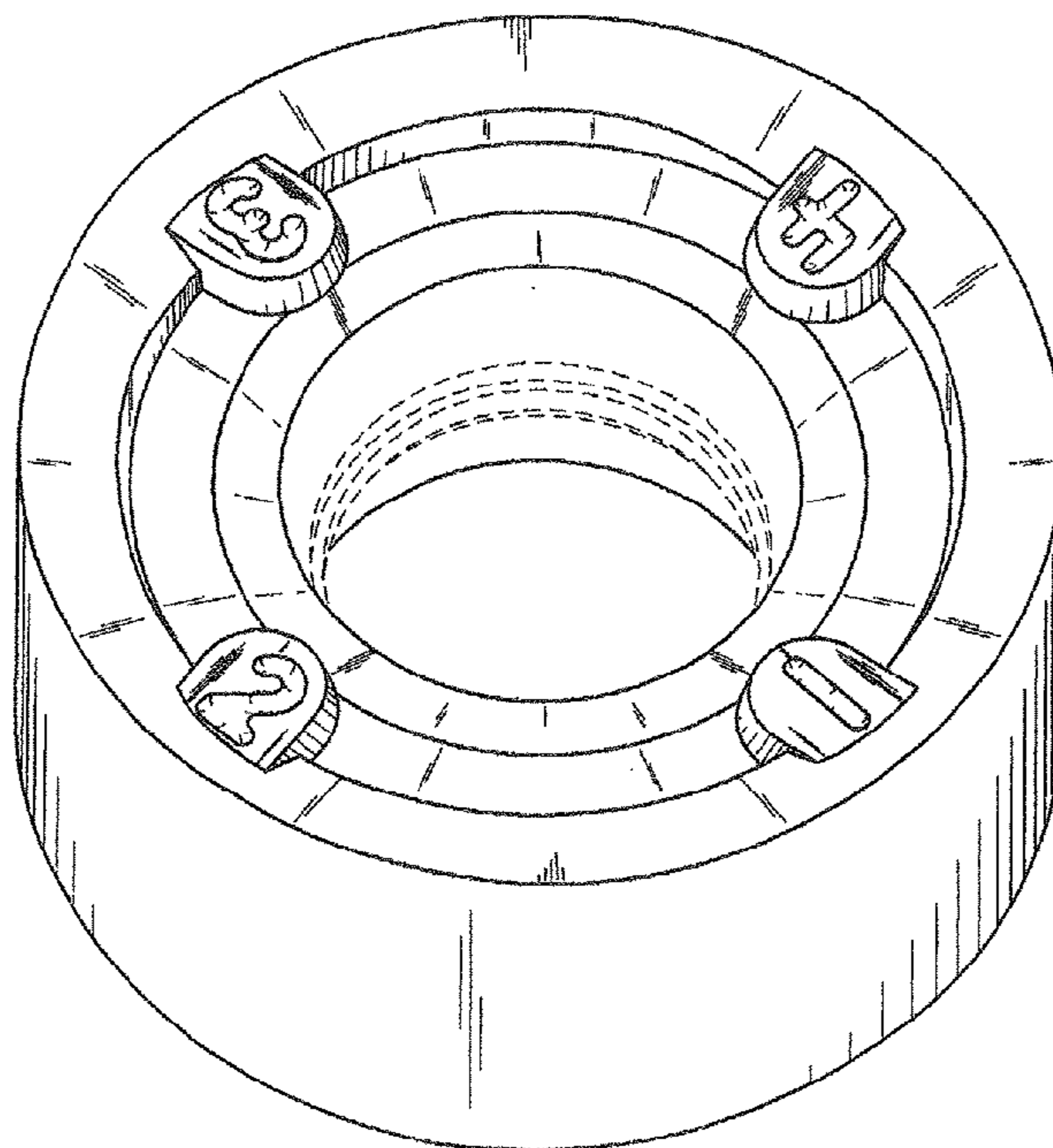

**FIG. 6**



**FIG. 7**

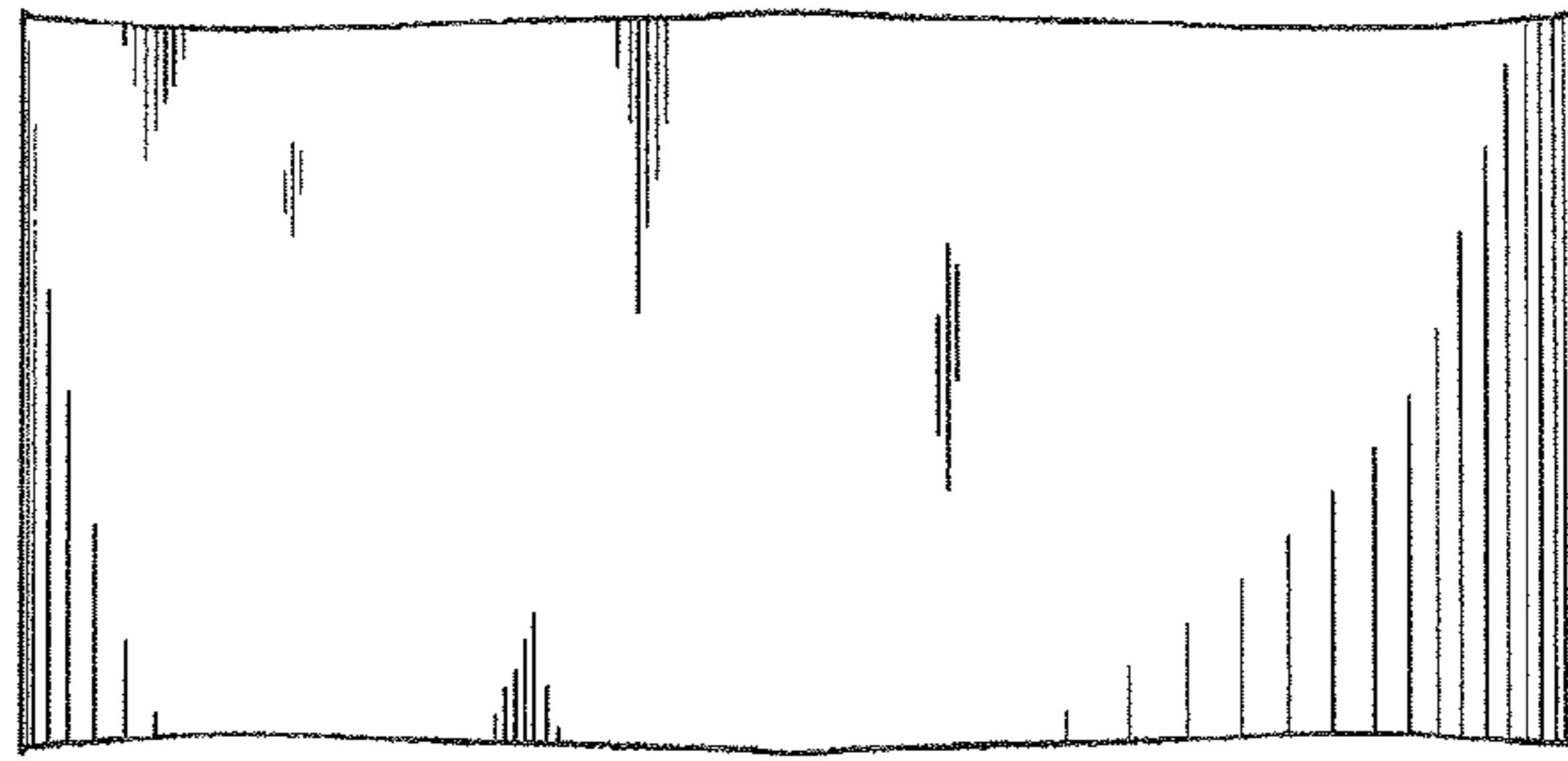

**FIG. 8**

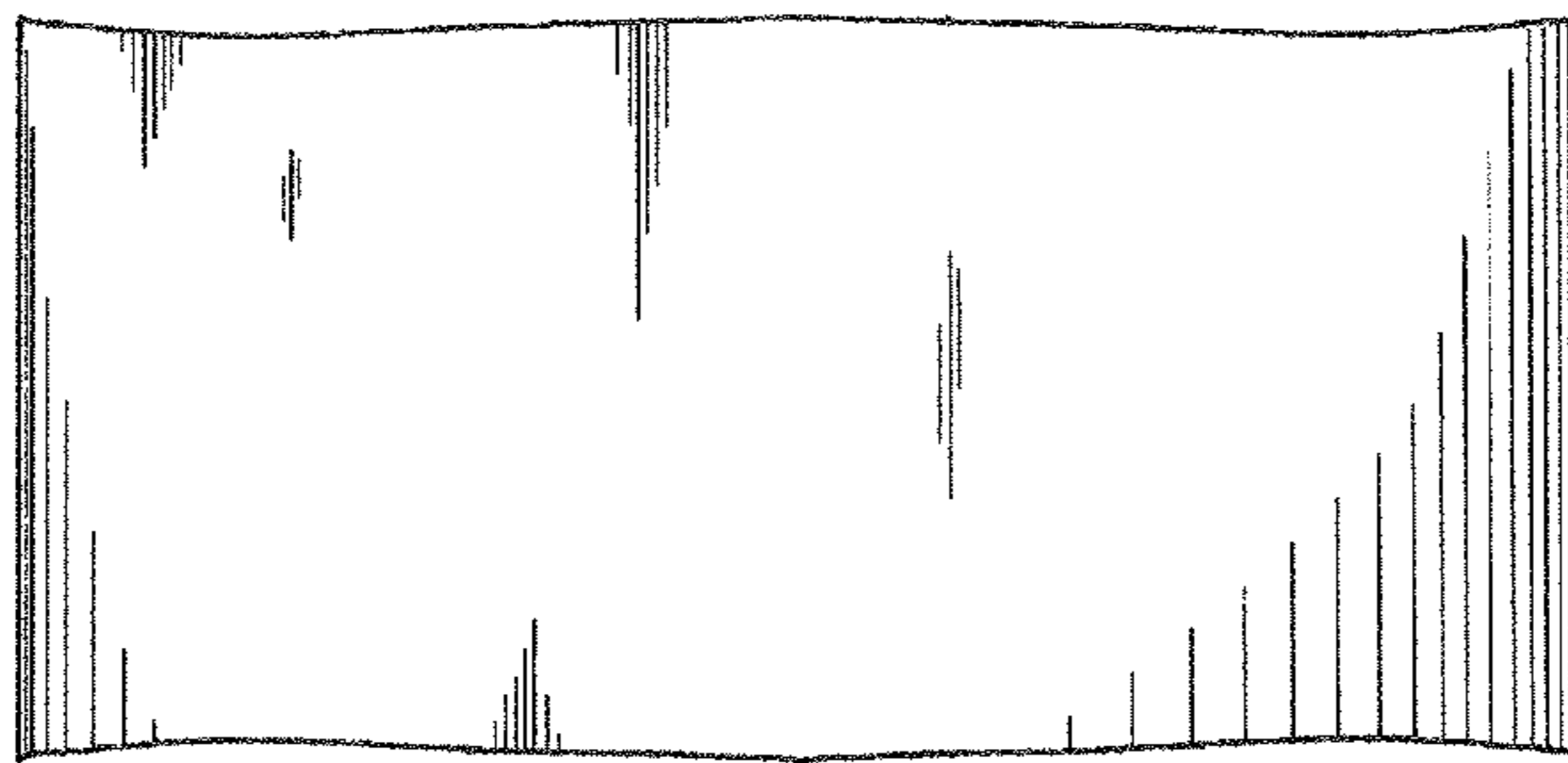

**FIG. 9**

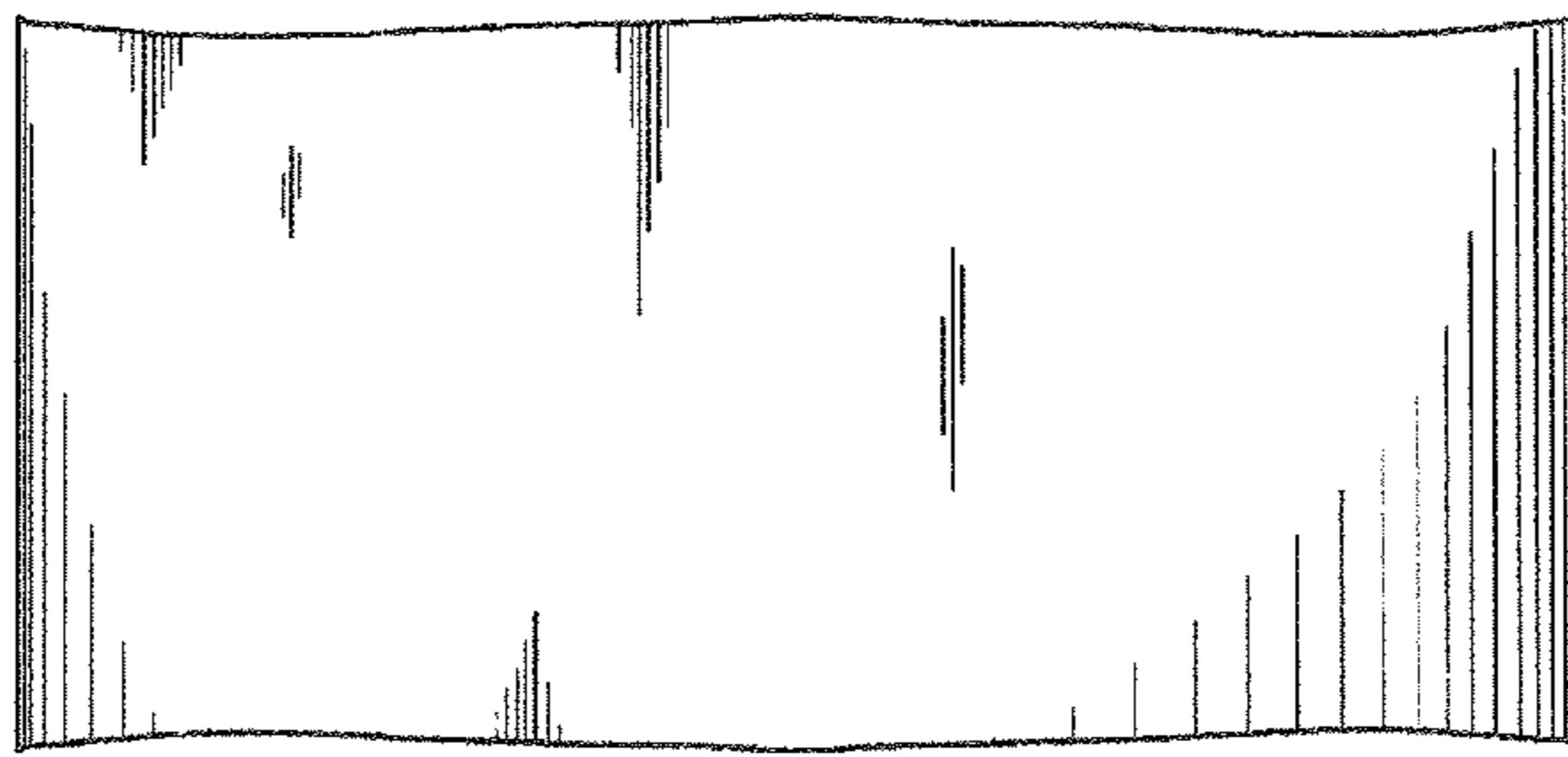

**FIG. 10**

