



US00D708999S

(12) **United States Design Patent**  
**Conway et al.**

(10) **Patent No.:** **US D708,999 S**  
(45) **Date of Patent:** **\*\* Jul. 15, 2014**

(54) **HOOD TOP**

(71) Applicants: **Scott M. Conway**, Flower Mound, TX (US); **Christopher M. Craig**, Forth Worth, TX (US); **Tu Hoang Do**, Lewisville, TX (US); **Derek Sancer**, Corinth, TX (US); **Jon F. Acton**, Winona, MS (US)

(72) Inventors: **Scott M. Conway**, Flower Mound, TX (US); **Christopher M. Craig**, Forth Worth, TX (US); **Tu Hoang Do**, Lewisville, TX (US); **Derek Sancer**, Corinth, TX (US); **Jon F. Acton**, Winona, MS (US)

(73) Assignee: **PACCAR Inc**, Bellevue, WA (US)

(\*\*) Term: **14 Years**

(21) Appl. No.: **29/447,427**

(22) Filed: **Mar. 4, 2013**

(51) **LOC (10) CI.** ..... **12-16**

(52) **U.S. CI.**  
USPC ..... **D12/173**

(58) **Field of Classification Search**  
USPC ..... D12/173, 196, 86, 90-92; 180/69.21, 180/69.2, 69.22  
See application file for complete search history.

(56) **References Cited**

**U.S. PATENT DOCUMENTS**

D50,345 S	2/1917	Green
D50,346 S	2/1917	Green
D366,340 S	1/1996	Porter
D366,638 S	1/1996	Tucker
D366,640 S	1/1996	Tucker
D382,239 S	8/1997	Logan
D382,841 S	8/1997	Norwood
D382,844 S	8/1997	Norwood
D395,860 S	7/1998	Meryman
D401,198 S	11/1998	Mueller
D403,636 S	1/1999	Meryman

D403,639 S	1/1999	Gale
D411,494 S	6/1999	Meryman
D412,689 S	8/1999	Onopa
D422,251 S	4/2000	Bader
D431,806 S	10/2000	Damon
D433,980 S	11/2000	Conway
D434,358 S	11/2000	Conway
D435,816 S	1/2001	Delashaw
D436,563 S	1/2001	Delashaw
D443,853 S	6/2001	Barraclough
D446,175 S	8/2001	Hoyle, Jr.

(Continued)

**OTHER PUBLICATIONS**

“AeroCab,” Kenworth Truck Company, Kirkland, Washington, 1993, 5-page brochure.

(Continued)

*Primary Examiner* — Melody Brown

(74) *Attorney, Agent, or Firm* — Christensen O’Connor Johnson Kindness PLLC

(57) **CLAIM**

The ornamental design for a hood top, as shown and described.

**DESCRIPTION**

FIG. 1 is a perspective view of a hood top according to our new design;  
FIG. 2 is top view of the hood top of FIG. 1;  
FIG. 3 is a front view of the hood top of FIG. 1;  
FIG. 4 is a left side elevational view of the hood top of FIG. 1; and,  
FIG. 5 is a right side elevational view of the hood top of FIG. 1.

The broken lines immediately adjacent the shaded areas, including those disposed around a portion of the periphery of the design as depicted in the FIGURES, represent the bounds of the claimed design while all other broken lines are directed to environment and are for illustrative purposes only; the broken lines form no part of the claimed design.

**1 Claim, 3 Drawing Sheets**

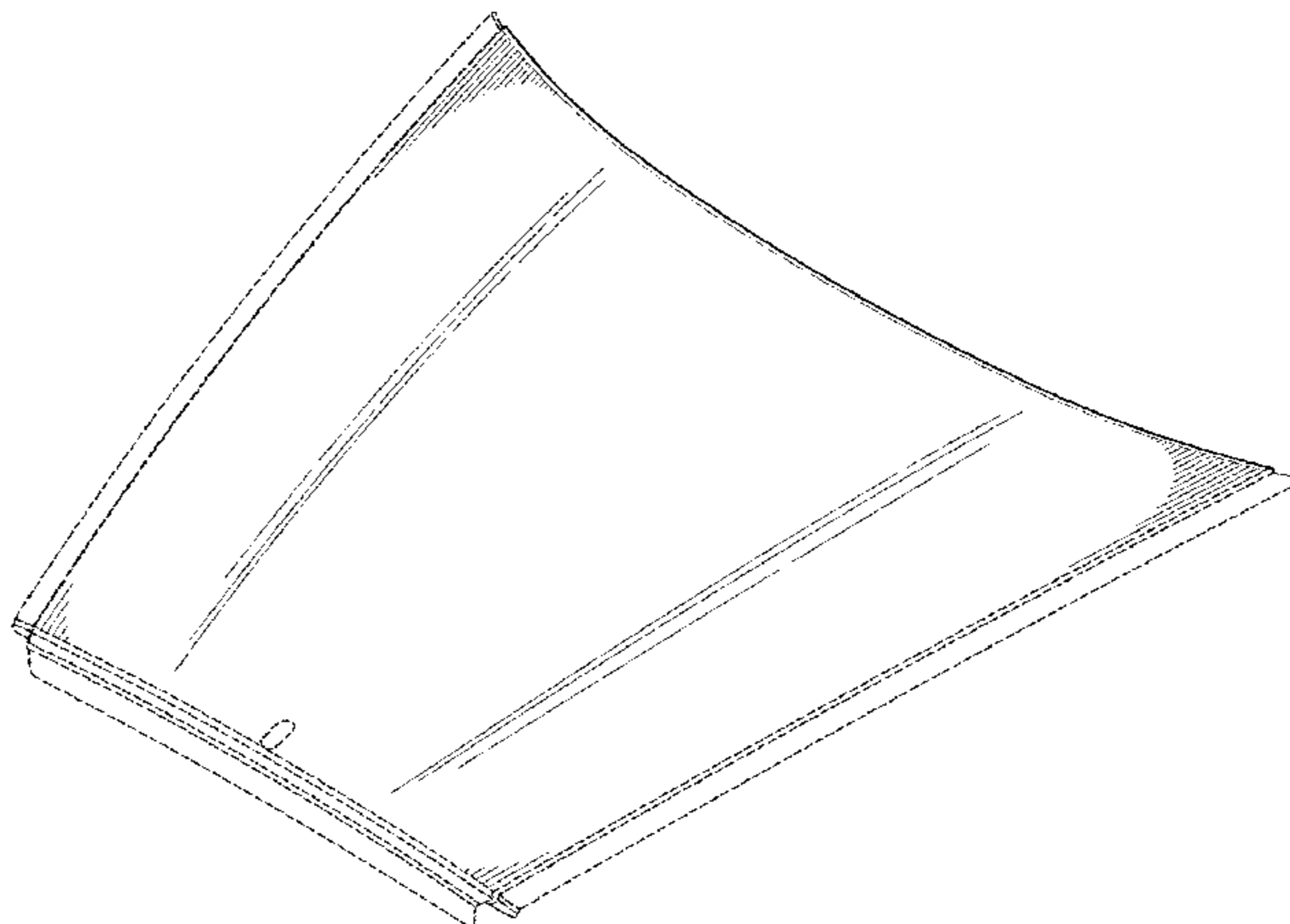

(56)

References Cited

U.S. PATENT DOCUMENTS

D450,277 S	11/2001	Onopa	
D460,023 S	7/2002	Beigel	
D465,749 S	11/2002	Beigel	
D466,450 S	12/2002	Maher	
D478,300 S	8/2003	Chiang	
D482,993 S	12/2003	Conway	
D484,077 S	12/2003	Conway	
D488,112 S	4/2004	Satou	
D490,749 S	6/2004	Satou	
D491,858 S	6/2004	Velazco	
D492,921 S	7/2004	Perfetti	
D494,900 S	8/2004	Satou	
D495,633 S	9/2004	Chiang	
D497,581 S	10/2004	Conway	
D502,901 S	3/2005	Delashaw	
D502,904 S	3/2005	Delashaw	
D504,642 S	5/2005	Perfetti	
D511,727 S	11/2005	Shaw	
D512,666 S	12/2005	Chiang	
D514,483 S	2/2006	Chiang	
D517,965 S	3/2006	Metros	
D518,761 S	4/2006	Chiang	
D523,793 S	6/2006	Beigel	
D524,204 S	7/2006	Beigel	
D531,947 S	11/2006	Angelo	
D532,350 S	11/2006	Angelo	
D532,352 S	11/2006	Angelo	
D540,725 S	4/2007	Gunter	
D540,727 S	4/2007	Elliott	
D545,250 S	6/2007	Angelo	
D545,251 S	6/2007	Angelo	
D545,254 S	6/2007	Angelo	
D545,255 S	6/2007	Angelo	
D560,575 S	1/2008	Simons	
D560,582 S	1/2008	Simons	
D560,583 S	1/2008	Simons	
D563,281 S	3/2008	Simons	
D563,849 S	3/2008	Medina	
D563,850 S	3/2008	Rosen	
D563,851 S	3/2008	Rosen	
D563,852 S	3/2008	Rosen	
D563,853 S	3/2008	Rosen	
D564,427 S	3/2008	Beigel	
D566,635 S	4/2008	Rosen	
D571,696 S	6/2008	Rosen	
D578,453 S	10/2008	Raghavendran	
D588,512 S	3/2009	Raghavendran	
D592,574 S	5/2009	Larson	
D597,003 S	7/2009	Yamazaki	
D605,986 S	12/2009	Raghavendran	
D619,941 S	7/2010	Krauss	
D621,754 S	8/2010	Angelo	
D622,188 S	8/2010	Angelo	
D632,234 S	2/2011	Peltola	
D643,352 S	8/2011	Hjorten	
D647,016 S	10/2011	Medina	
D647,832 S	11/2011	Medina	
D654,401 S	2/2012	Peltola	
D654,417 S	2/2012	Peltola	
D690,242 S *	9/2013	Conway et al. ....	D12/173
D690,632 S *	10/2013	Peltola et al. ....	D12/173
2013/0025954 A1	1/2013	Miller	

OTHER PUBLICATIONS

“AeroCab,” Kenworth Truck Company, Kirkland, Washington, as early as 1995, 3-page brochure.  
 “C500B,” Kenworth Truck Company, Kirkland, Washington, as early as 1990, 4-page brochure.  
 “Class Pays, Medium Duty,” Peterbilt Motors Company, Denton, Texas, Sep. 2000, 12-page brochure.  
 “Class Pays, Truck Models,” Peterbilt Motors Company, Denton, Texas, Mar. 2005, 24-page brochure.  
 “Class Pays,” Peterbilt Motors Company, Denton, Texas, Nov. 1998, 10-page brochure.

Class Pays, Peterbilt Motors Company, Denton, Texas, Sep. 1997, 10-page brochure.  
 Class Pays, Construction Trucks, Peterbilt Motors Company, Denton, Texas, Nov. 2003, 16-page brochure.  
 “Kenworth Truck Models,” Kenworth Truck Company, Kirkland, Washington, 2010, 16-page brochure.  
 “Model 330,” Peterbilt Motors Company, Denton, Texas, Oct. 1997, 3-page brochure.  
 “Model 357 Heavy Haul,” Peterbilt Motors Company, Denton, Texas, Mar. 2005, 2-page brochure.  
 “Model 357 Standard Specifications,” Peterbilt Motors Company, Newark, California, Sep. 1986, 6-page brochure.  
 “Model 357, New Sloped Hood,” Peterbilt Motors Company, Denton, Texas, May 2002, 2-page brochure.  
 “Model 357,” Peterbilt Motors Company, Denton, Texas, May 1994, 3-page brochure.  
 “Model 357-115,” Peterbilt Motors Company, Denton, Texas, Mar. 2005, 2-page brochure.  
 “Model 375 Standard Specifications,” Peterbilt Motors Company, Newark, California, Sep. 1986, 6-page brochure.  
 “Model 377A/E,” Peterbilt Motors Company, Denton, Texas, Aug. 1997, 2-page brochure.  
 “Model 377A/E,” Peterbilt Motors Company, Denton, Texas, Jan. 1995, 6-page brochure.  
 “Model 378,” Peterbilt Motors Company, Denton, Texas, Mar. 1998, 3-page brochure.  
 “Model 379,” Peterbilt Motors Company, Denton, Texas, Apr. 2005, 2-page brochure.  
 “Model 379,” Peterbilt Motors Company, Denton, Texas, Mar. 1996, 5-page brochure.  
 “Model 385,” Peterbilt Motors Company, Denton, Texas, Oct. 1996, 5-page brochure.  
 “Model 387,” Peterbilt Motors Company, Denton, Texas, Oct. 2002, 2-page brochure.  
 Rest with Class, Peterbilt Motors Company, Newark, California, Apr. 1978, 4-page brochure.  
 “T170 Class 5,” Kenworth Truck Company, Kirkland, Washington, 2008, 4-page brochure.  
 “T2000,” Kenworth Truck Company, Kirkland, Washington, 1999, 20-page brochure.  
 “T2000,” Kenworth Truck Company, Kirkland, Washington, 2002, 20-page brochure.  
 “T2000,” Kenworth Truck Company, Kirkland, Washington, 2005, 20-page brochure.  
 “T270 Class 6 and T370 Class 7,” Kenworth Truck Company, Kirkland, Washington, 2008, 6-page brochure.  
 “T270 Class 6 and T370 Class 7,” Kenworth Truck Company, Kirkland, Washington, 2009, 6-page brochure.  
 “T270 Class 6 and T370 Class 7 Hybrid,” Kenworth Truck Company, Kirkland, Washington, 2009, 6-page brochure.  
 “T300,” Kenworth Truck Company, Kirkland, Washington, 1994, 4-page brochure.  
 “T300,” Kenworth Truck Company, Kirkland, Washington, 2001, 16-page brochure.  
 “T300,” Kenworth Truck Company, Kirkland, Washington, 2005, 16-page brochure.  
 “T440,” Kenworth Truck Company, Kirkland, Washington, 2010, 2-page brochure.  
 “T440,” Kenworth Truck Company, Kirkland, Washington, 2010, 6-page brochure.  
 “T470,” Kenworth Truck Company, Kirkland, Washington, 2010, 6-page brochure.  
 “T470H,” Kenworth Truck Company, Kirkland, Washington, 2009, 2-page brochure.  
 “T600,” Kenworth Truck Company, Kirkland, Washington, 1996, 7-page brochure.  
 “T600,” Kenworth Truck Company, Kirkland, Washington, 2002, 28-page brochure.  
 “T600,” Kenworth Truck Company, Kirkland, Washington, 2005, 24-page brochure.  
 “T600A,” Kenworth Truck Company, Kirkland, Washington, 1985, 10-page brochure.

(56)

**References Cited**

OTHER PUBLICATIONS

“T660,” Kenworth Truck Company, Kirkland, Washington, 2007, 36-page brochure.  
“T660,” Kenworth Truck Company, Kirkland, Washington, 2009, 36-page brochure.  
“T700,” Kenworth Truck Company, Kirkland, Washington, 2010, 6-page brochure.  
“T800,” Kenworth Truck Company, Kirkland, Washington, 1996, 7-page brochure.  
“T800,” Kenworth Truck Company, Kirkland, Washington, 2002, 32-page brochure.  
“T800,” Kenworth Truck Company, Kirkland, Washington, 2003, 32-page brochure.  
“T800,” Kenworth Truck Company, Kirkland, Washington, 2005, 28-page brochure.  
“T800,” Kenworth Truck Company, Kirkland, Washington, 2009, 28-page brochure.

“T800B,” Kenworth Truck Company, Kirkland, Washington, 1993, 8-page brochure.  
“The Working Class,” Peterbilt Motors Company, Newark, California, Sep. 1976, 6-page brochure.  
“The World’s Best,” Kenworth Truck Company, Kirkland, Washington, 1992, 12-page brochure.  
“Unibilt™ Cab Sleeper System,” Peterbilt Motors Company, Denton Texas, Aug. 1994, 6-page brochure.  
“W900,” Kenworth Truck Company, Kirkland, Washington, 1996, 7-page brochure.  
“W900,” Kenworth Truck Company, Kirkland, Washington, 2002, 32-page brochure.  
“W900,” Kenworth Truck Company, Kirkland, Washington, 2005, 28-page brochure.  
“W900,” Kenworth Truck Company, Kirkland, Washington, 2009, 28-page brochure.  
“W900L Aero Cab,” Kenworth Truck Company, Kirkland, Washington, 1994, 2-page brochure.

\* cited by examiner

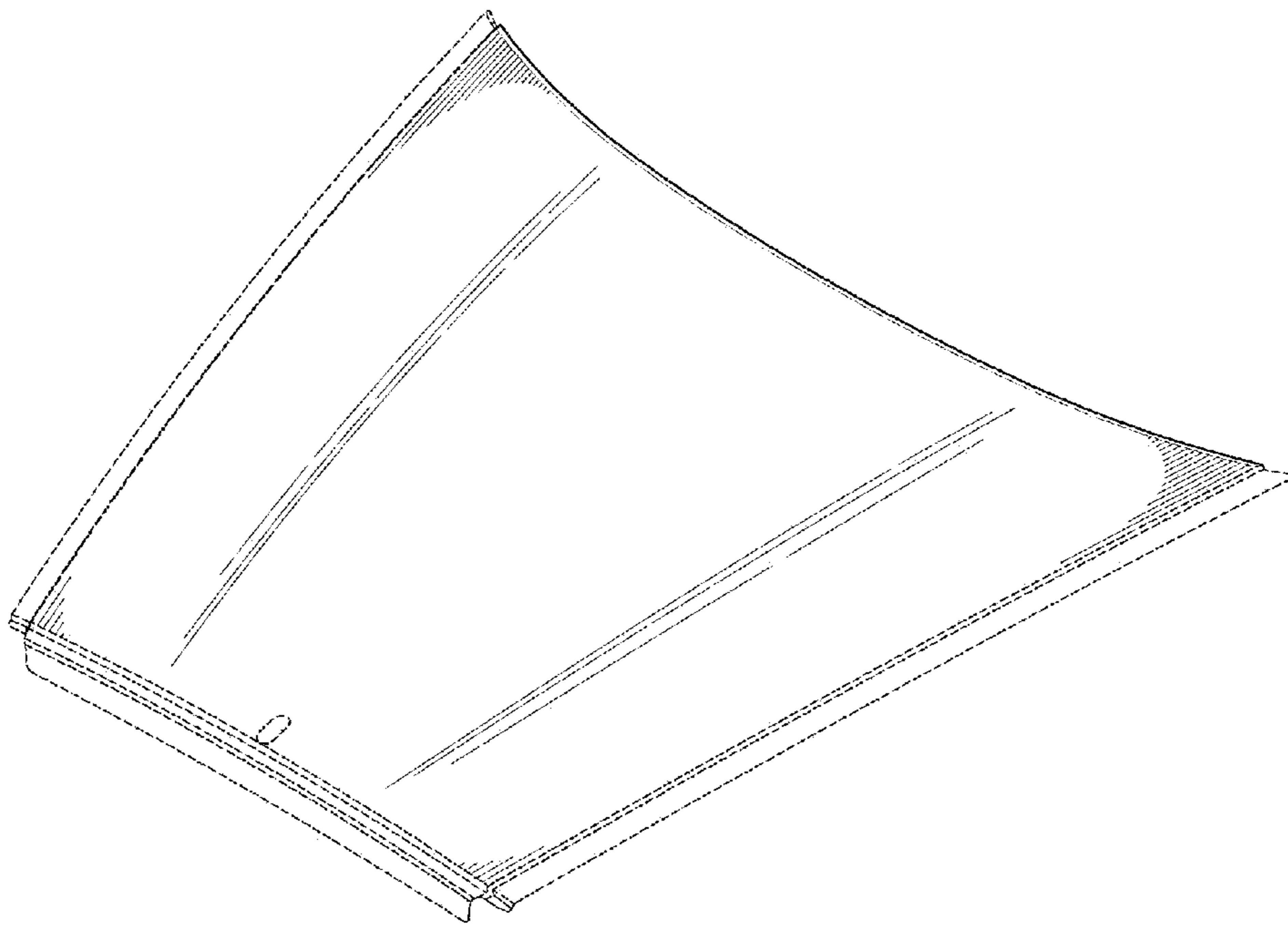

*Fig. 1.*

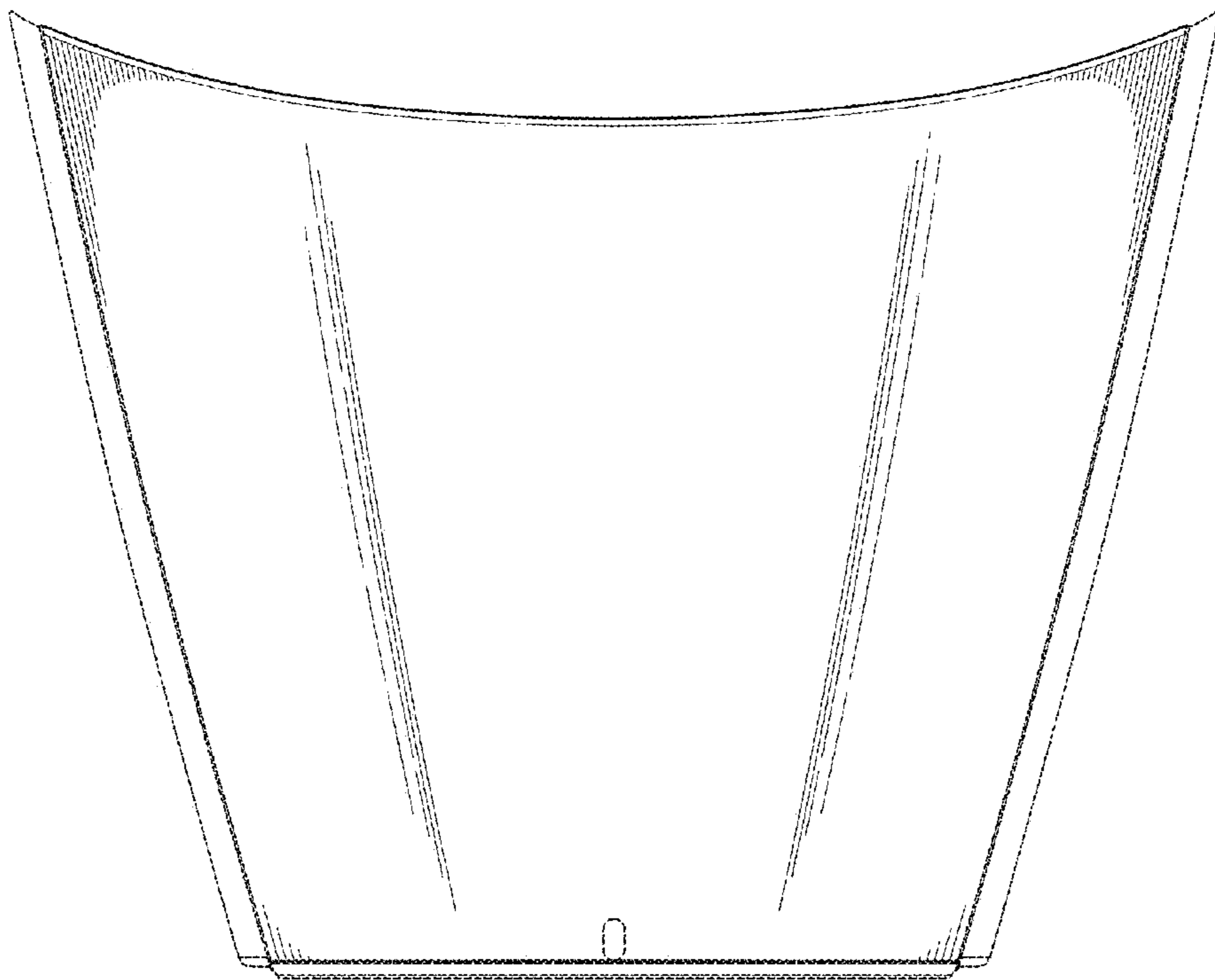

*Fig. 2.*

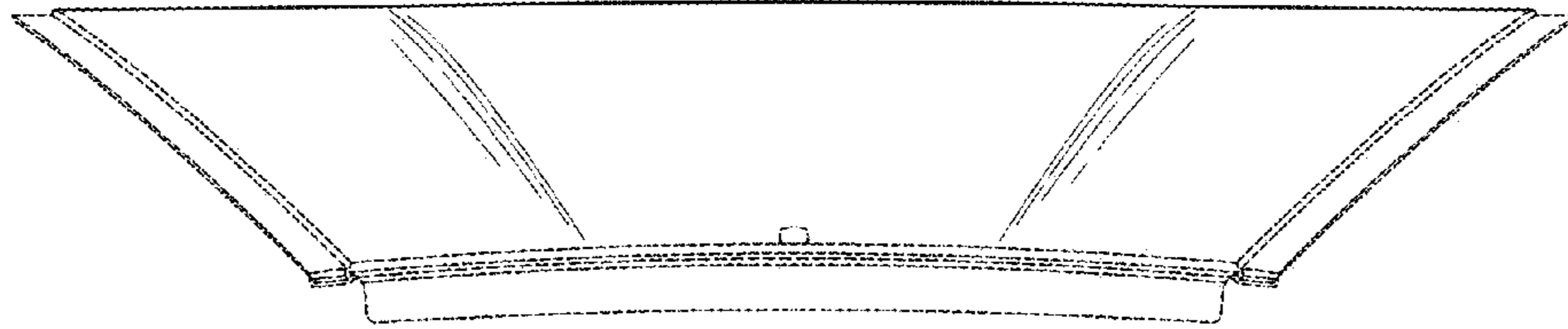

*Fig. 3.*

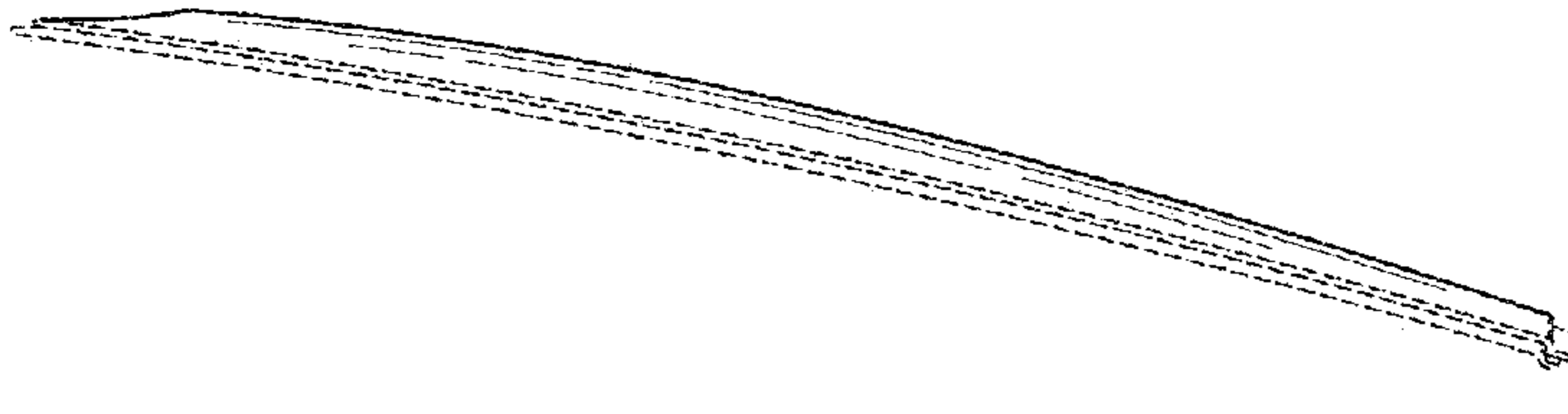

*Fig. 4.*

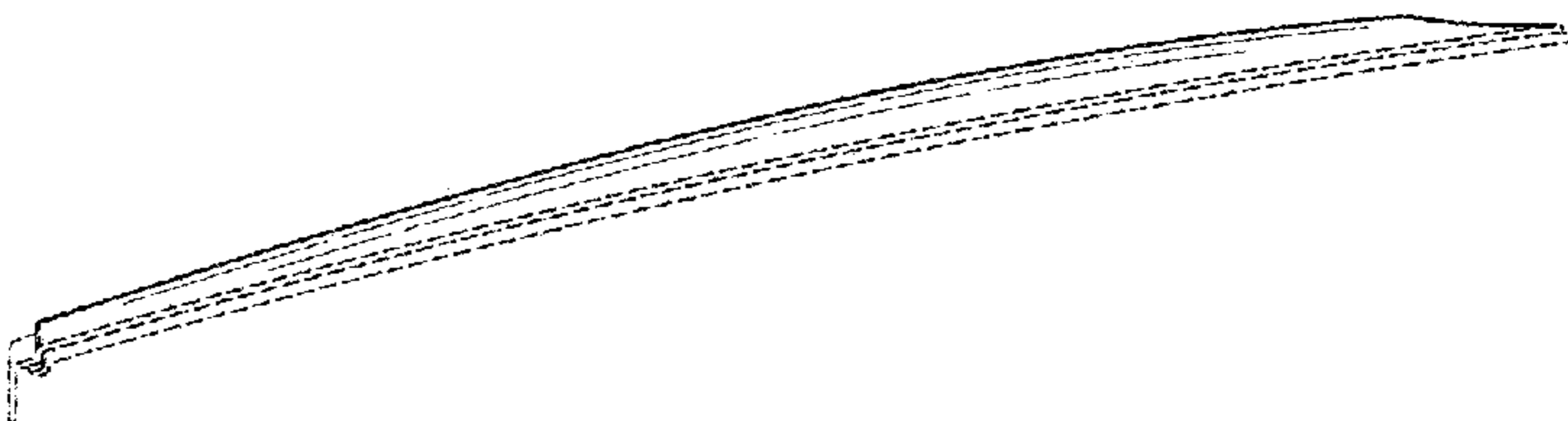

*Fig. 5.*

UNITED STATES PATENT AND TRADEMARK OFFICE  
**CERTIFICATE OF CORRECTION**

PATENT NO. : D708,999 S  
APPLICATION NO. : 29/447427  
DATED : July 15, 2014  
INVENTOR(S) : Conway et al.

Page 1 of 1

It is certified that error appears in the above-identified patent and that said Letters Patent is hereby corrected as shown below:

On the Title Page

**COLUMN**

**LINE**

Item [71]                      lines 2–3                      Delete “Forth Worth” and insert --Fort Worth--  
col. 1

Item [72]                      lines 2–3                      Delete “Forth Worth” and insert --Fort Worth--  
col. 1

Signed and Sealed this  
Fourteenth Day of October, 2014



Michelle K. Lee  
*Deputy Director of the United States Patent and Trademark Office*