



US00D708358S

(12) **United States Design Patent**  
**Masaneck, Jr.**

(10) **Patent No.:** **US D708,358 S**

(45) **Date of Patent:** **\*\* Jul. 1, 2014**

- (54) **TOP SURFACE OF A FLOOR TILE**
- (71) Applicant: **MacNeil IP LLC**, Bolingbrook, IL (US)
- (72) Inventor: **Frederick W. Masaneck, Jr.**, Barrington, IL (US)
- (73) Assignee: **MacNeil IP LLC**, Bolingbrook, IL (US)
- (\*\*) Term: **14 Years**
- (21) Appl. No.: **29/472,499**
- (22) Filed: **Nov. 13, 2013**

2,627,744	A *	2/1953	Lopina .....	52/309.1
3,041,785	A *	7/1962	MacDonald et al. ....	52/309.3
D200,313	S *	2/1965	Monroe .....	D25/163
3,192,097	A	6/1965	Abernethy	
3,418,668	A	12/1968	Anderson et al.	
3,699,926	A	10/1972	Stockl	
3,909,996	A	10/1975	Ettlinger, Jr. et al.	
6,647,684	B1 *	11/2003	Gank .....	52/385
7,114,298	B2	10/2006	Kotler	
7,757,449	B2	7/2010	Portoles Ibanez et al.	
8,266,857	B2	9/2012	David	

**Related U.S. Application Data**

- (60) Division of application No. 29/460,262, filed on Jul. 9, 2013, now Pat. No. Des. 703,347, which is a continuation of application No. 12/609,959, filed on Oct. 30, 2009, now Pat. No. 8,535,785, and a continuation of application No. 13/662,181, filed on Oct. 26, 2012.
- (51) **LOC (10) Cl.** ..... **25-01**
- (52) **U.S. Cl.**  
USPC ..... **D25/163**
- (58) **Field of Classification Search**  
USPC ..... D25/163, 138, 149; 428/48, 49, 50, 52, 428/33, 172; 52/311.1, 311.2, 311.3, 314, 52/316, 384, 385, 389, 302.1, 309.1, 52/309.3; D5/4, 62  
See application file for complete search history.

**References Cited**

**U.S. PATENT DOCUMENTS**

348,782	A	9/1886	Sawyer	
1,440,967	A *	1/1923	Carpenter et al. ....	52/389

**FOREIGN PATENT DOCUMENTS**

JP 02018046 A 1/1990

\* cited by examiner

*Primary Examiner* — Doris Clark

(74) *Attorney, Agent, or Firm* — Perkins IP Law Group LLC; Jefferson Perkins

(57) **CLAIM**

The ornamental design for a top surface of a floor tile, as shown and described.

**DESCRIPTION**

FIG. 1 is an isometric view of my design, the sides of the tile being shown in broken line as environmental structure; FIG. 2 is a plan view of my design, the sides of the tile being shown in broken line as environmental structure; and, FIG. 3 is a side elevation view, the bottom and sides of the tile being shown in broken line as environmental structure. The broken line showing of the environment is for illustrative purposes only and forms no part of the claimed design.

**1 Claim, 1 Drawing Sheet**

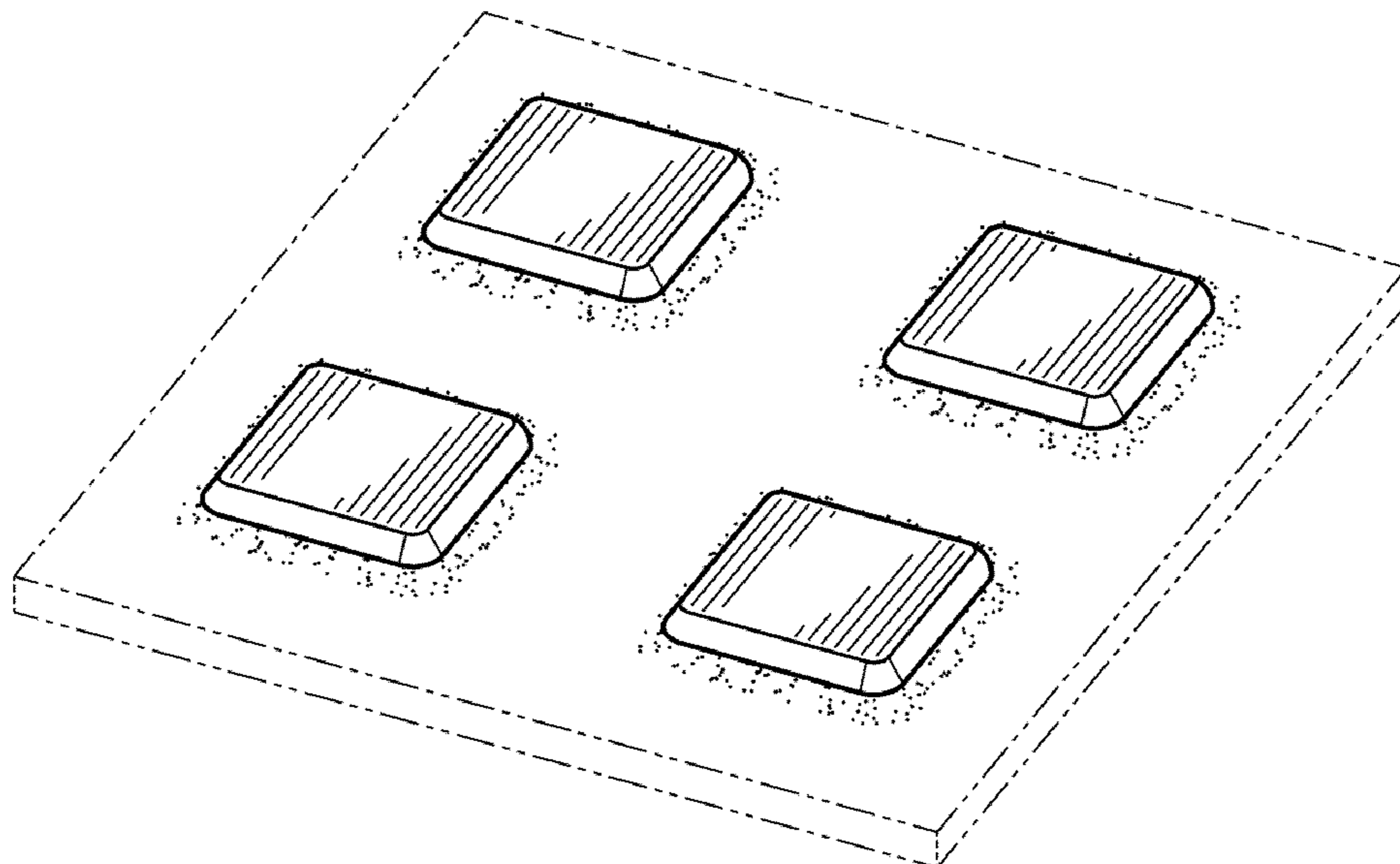

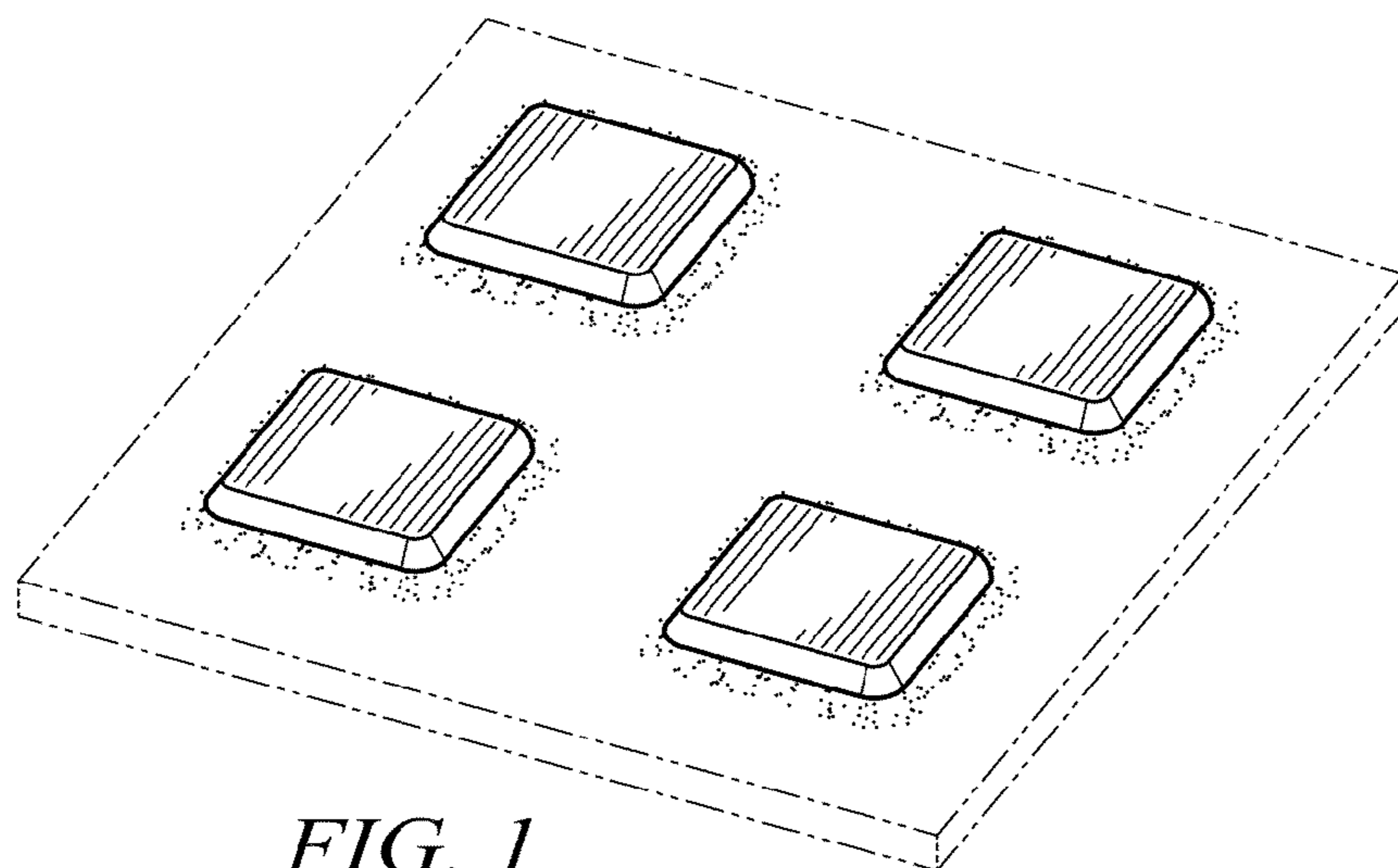

FIG. 1

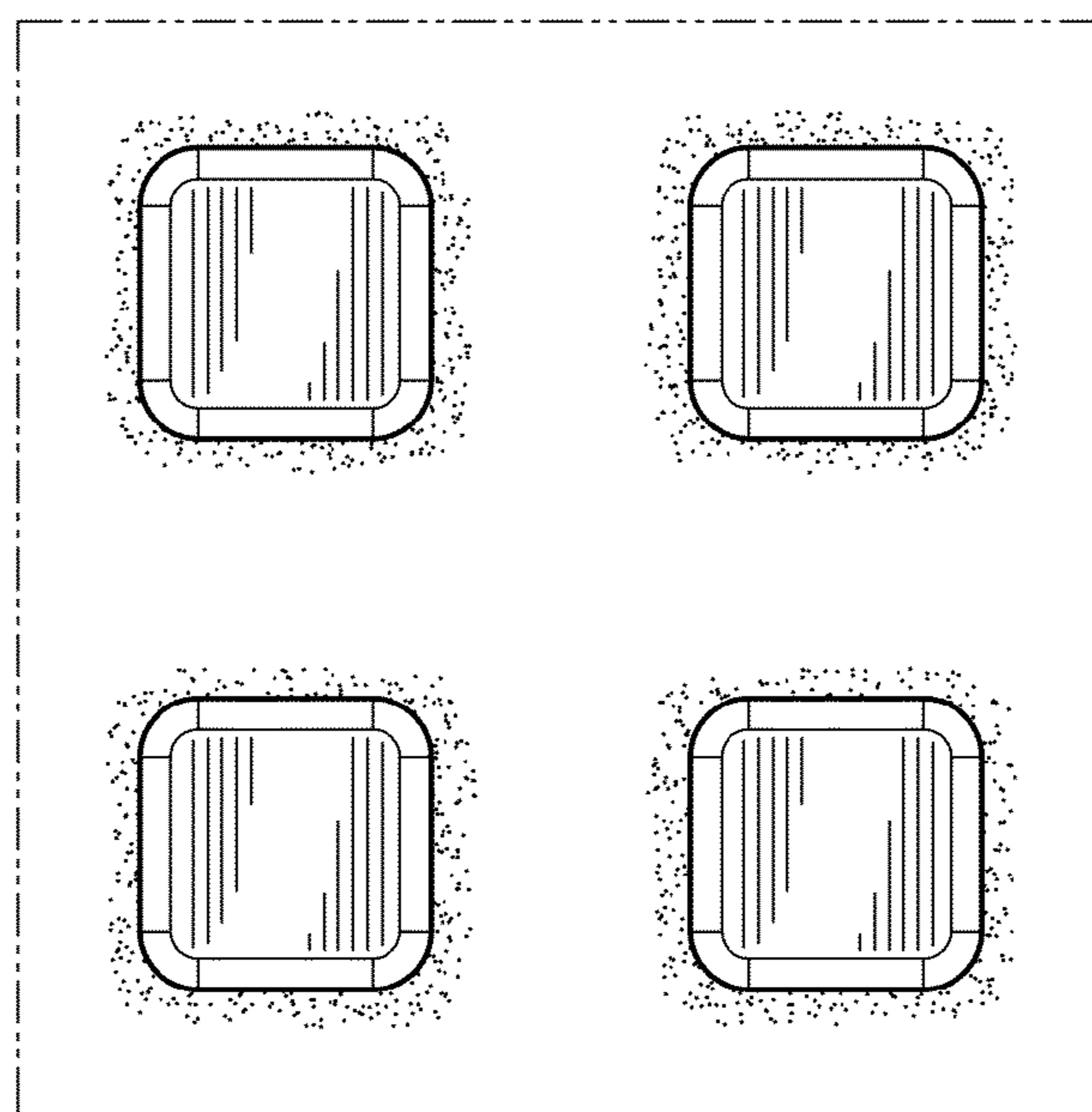

FIG. 2

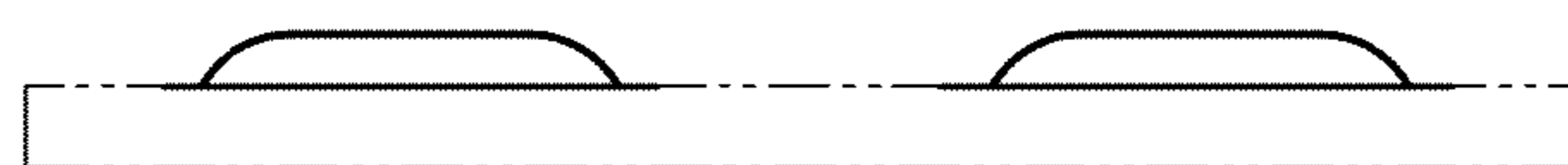

FIG. 3