



US00D708253S

(12) **United States Design Patent**  
**Braithwaite**(10) **Patent No.:** US D708,253 S(45) **Date of Patent:** \*\* Jul. 1, 2014

(54) **DOUBLE BELL JUNCTURE FOR TWO WOODWIND INSTRUMENTS**

(76) Inventor: **George T. Braithwaite**, Staten Island, NY (US)

(\*\*) Term: **14 Years**

(21) Appl. No.: **29/414,713**

(22) Filed: **Mar. 2, 2012**

(51) **LOC (10) Cl.** ..... **17-02**

(52) **U.S. Cl.**  
USPC ..... **D17/13**

(58) **Field of Classification Search**  
USPC ..... D17/10, 11, 13, 99; 84/330, 380 R, 381, 84/382, 383 A, 384, 385 R, 386, 387 R, 84/391, 395, 398, 400, 453, 456, 470 R; D21/405, 411  
See application file for complete search history.

(56) **References Cited**

## U.S. PATENT DOCUMENTS

149,540 A *	4/1874	Sporrer	84/378
637,261 A *	11/1899	Irving	446/416
1,169,358 A	1/1916	Schilzonyi	
1,288,235 A	12/1918	Shilzony	
D69,905 S *	4/1926	Mussehl	D17/10
1,857,908 A	5/1932	Hathaway	

D92,963 S *	8/1934	Holtz	D14/207
D114,960 S *	5/1939	Nielsen	D10/120
2,232,151 A	2/1941	Trew	
D159,738 S *	8/1950	Legler	D17/10
3,529,505 A *	9/1970	Brooks	84/387 R
4,341,146 A	7/1982	Massa	
D320,997 S *	10/1991	Katsuhara	D17/10
D407,100 S *	3/1999	Marcinkiewicz	D17/11
6,060,654 A *	5/2000	Valtchev et al.	84/453

\* cited by examiner

*Primary Examiner* — Rashida Johnson(74) *Attorney, Agent, or Firm* — Howard Natter; Natter & Natter(57) **CLAIM**

The ornamental design for a double bell juncture for two woodwind instruments, as shown and described.

**DESCRIPTION**

FIG. 1 is a reduced perspective view of a double bell juncture for two woodwind instruments showing my new design;

FIG. 2 is a top plan view;

FIG. 3 is a front elevational view;

FIG. 4 is a right side elevational view;

FIG. 5 is a left side elevational view;

FIG. 6 is a rear elevational view; and,

FIG. 7 is a bottom plan view.

The broken-line showing of FIG. 1 illustrates environmental structure that forms no part of the design to be patented.

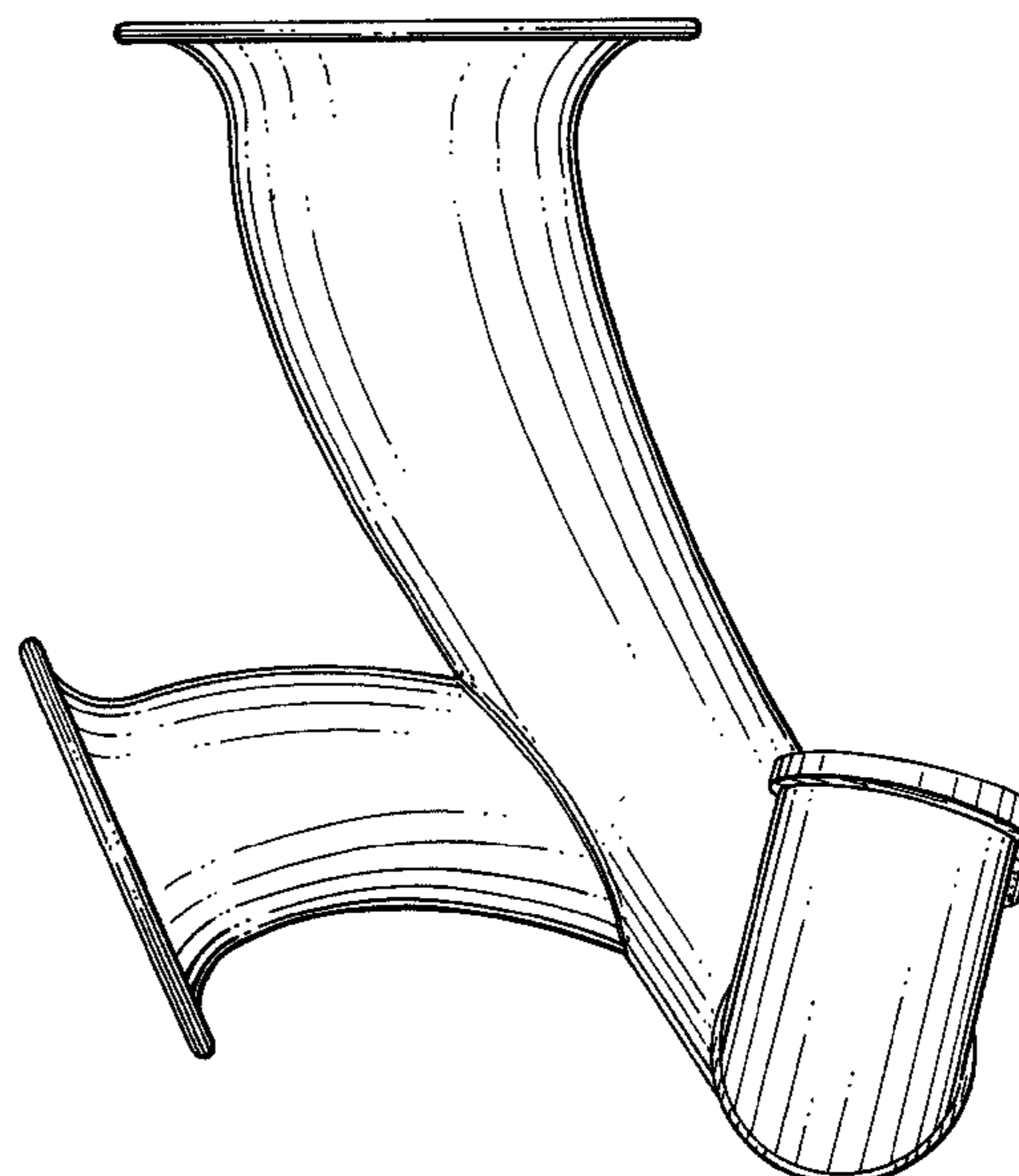
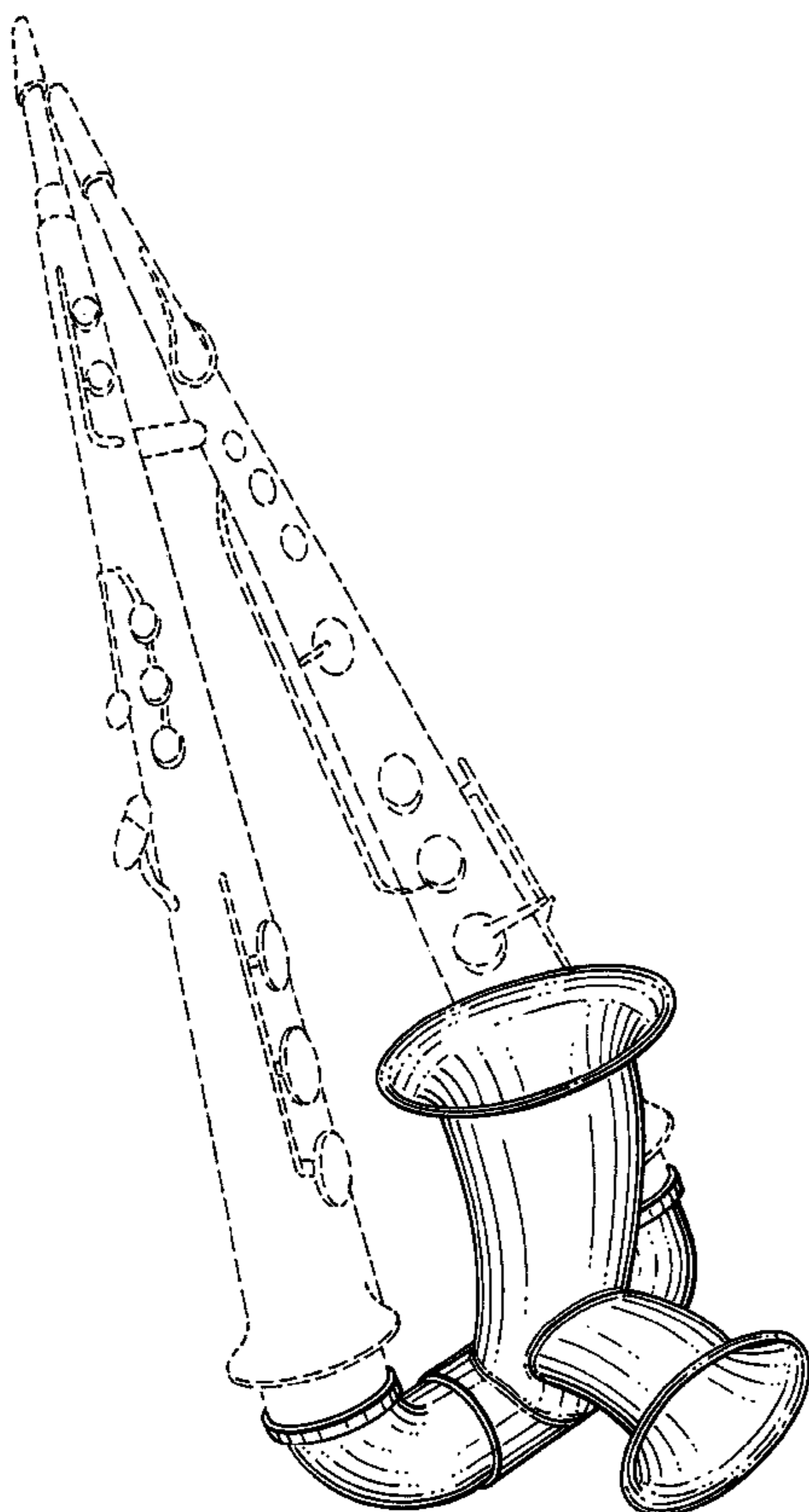
**1 Claim, 7 Drawing Sheets**

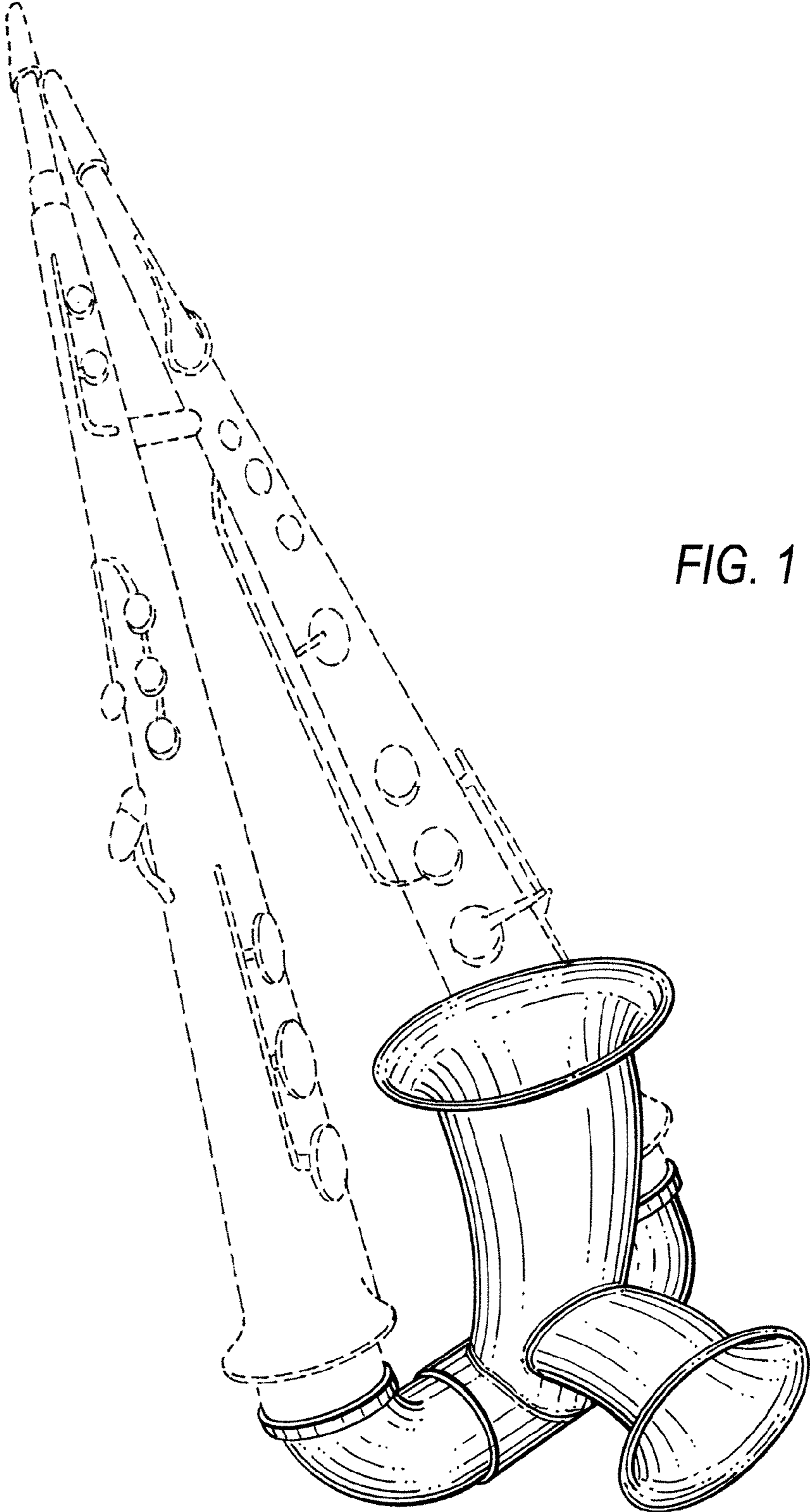

FIG. 1

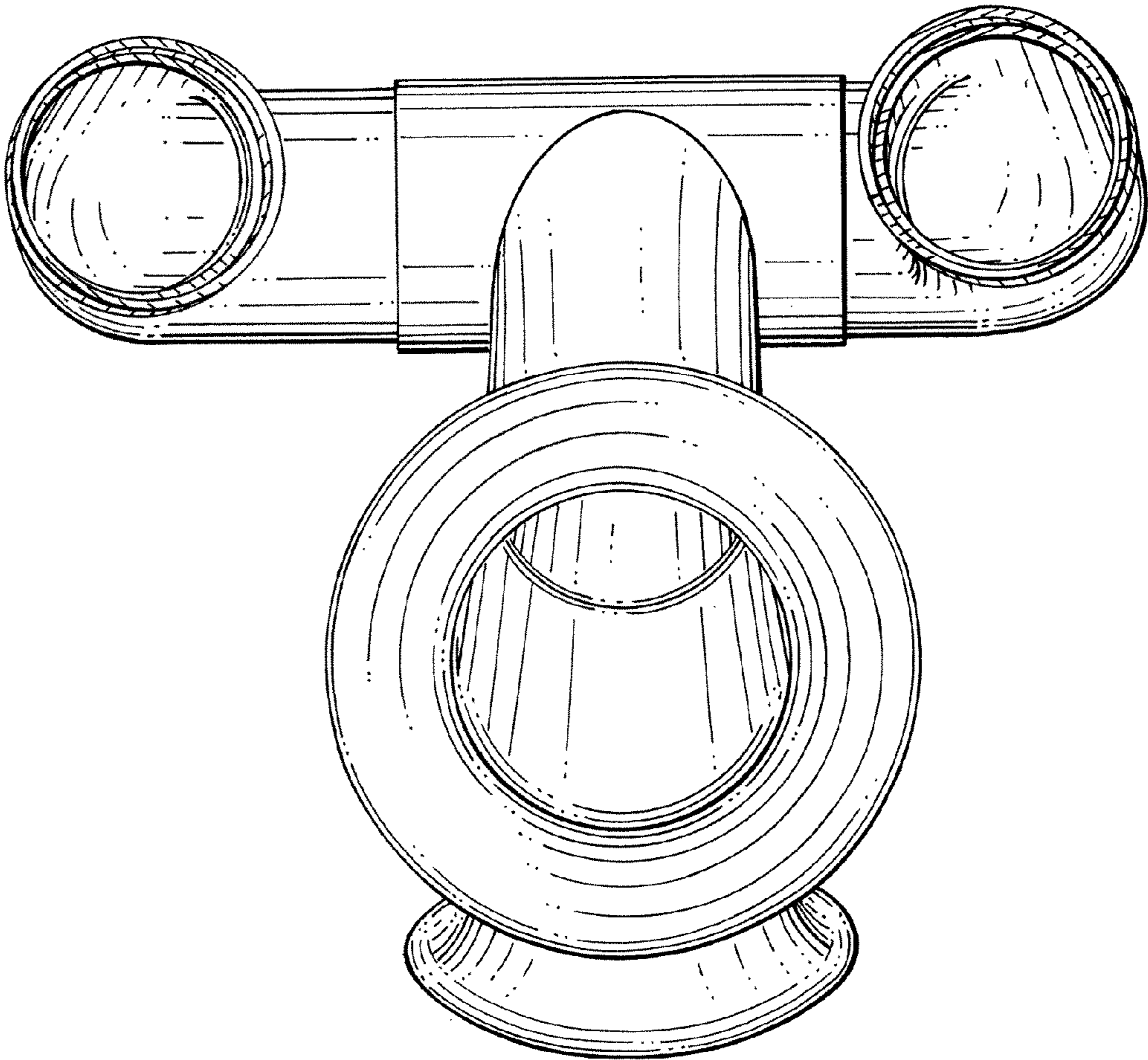

FIG. 2

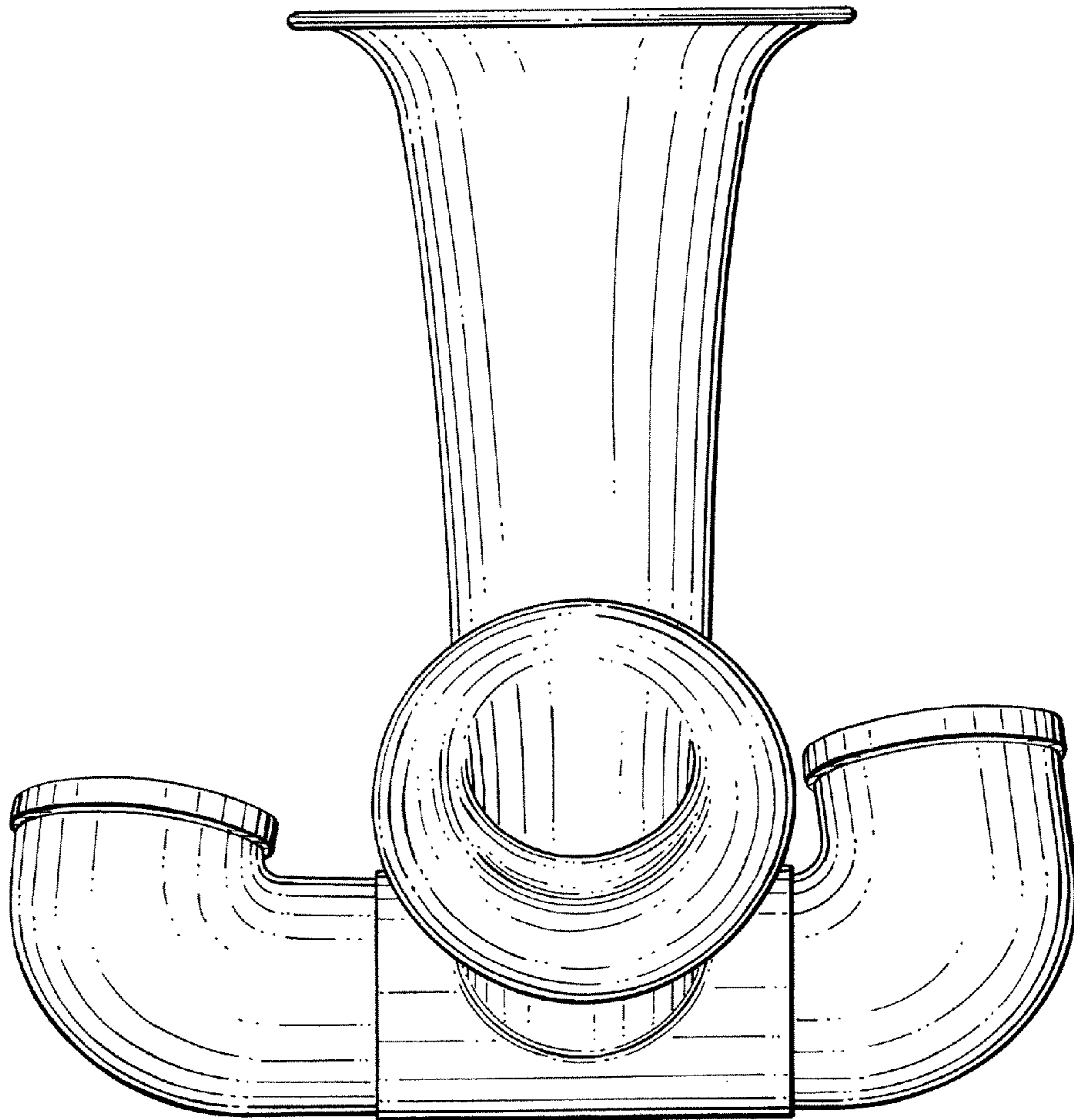

FIG. 3

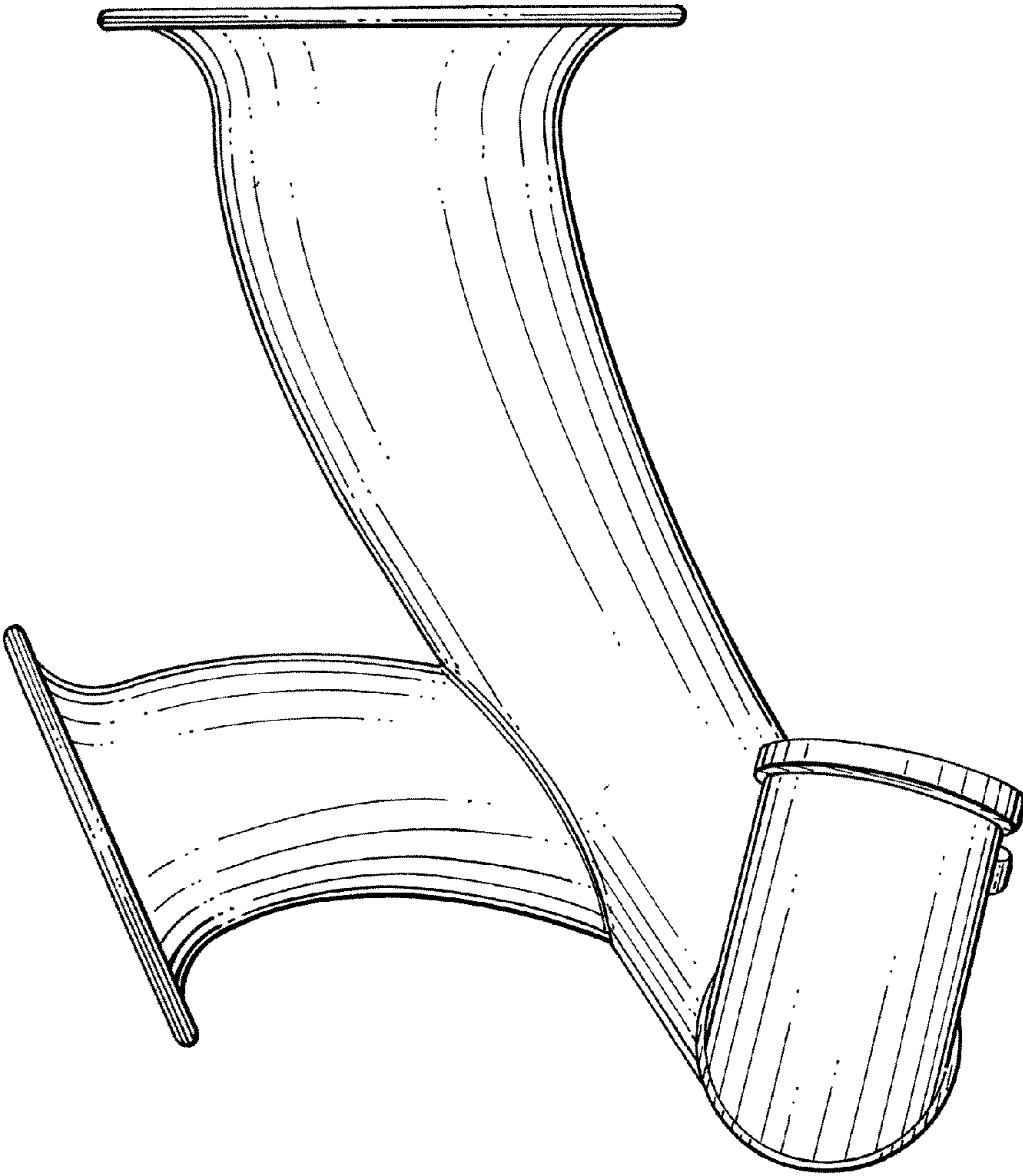

FIG. 4

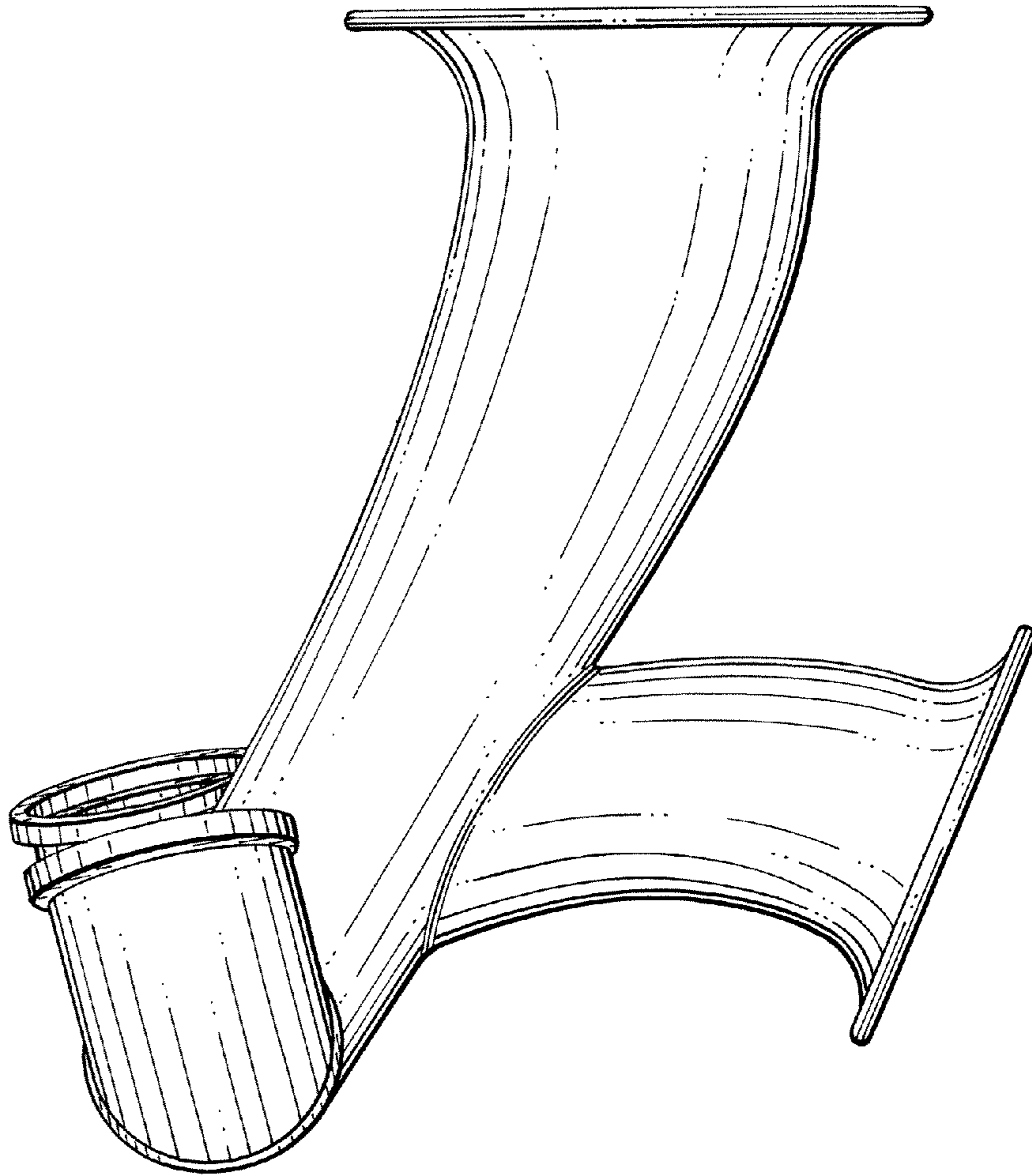

FIG. 5

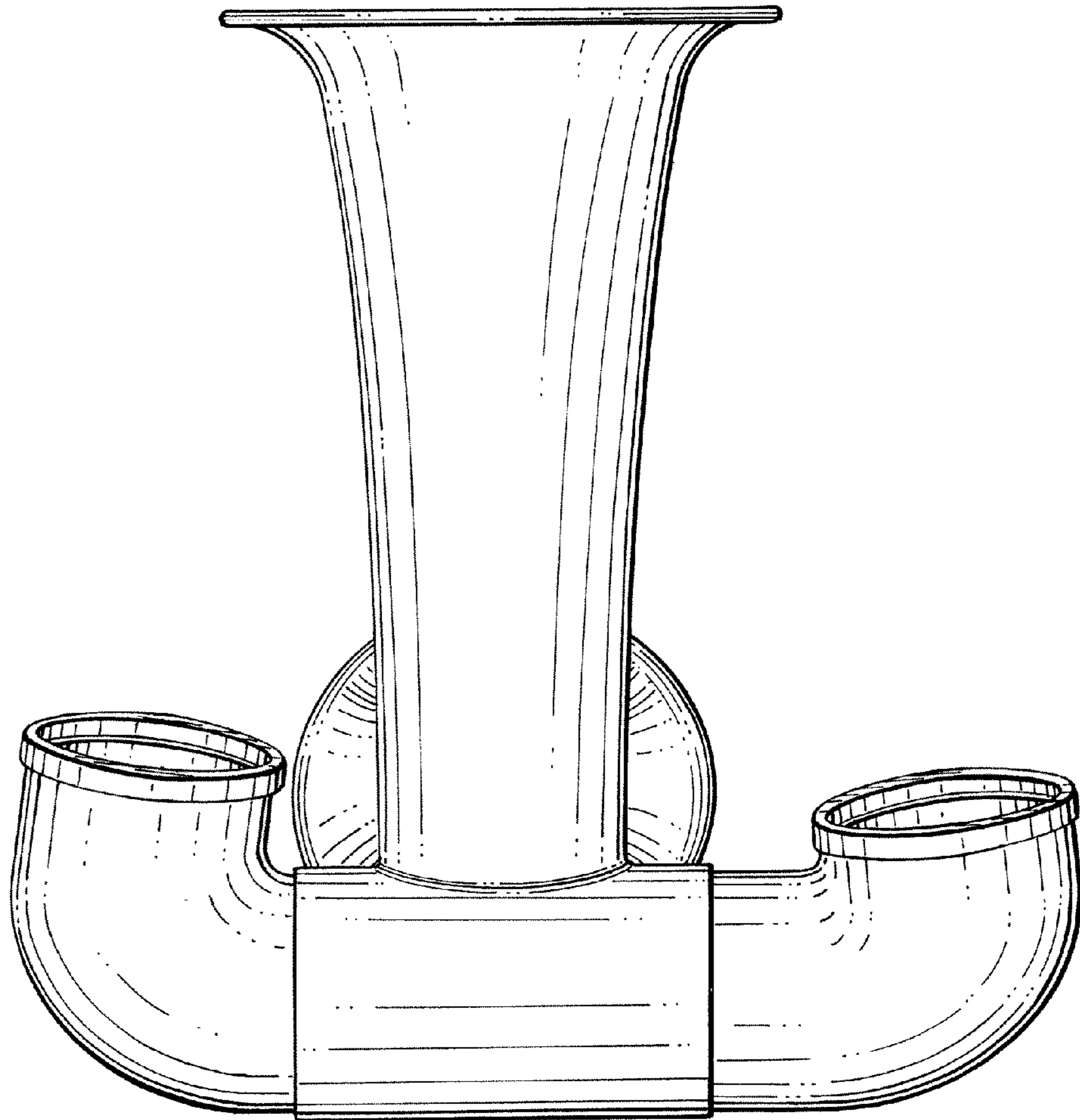

FIG. 6

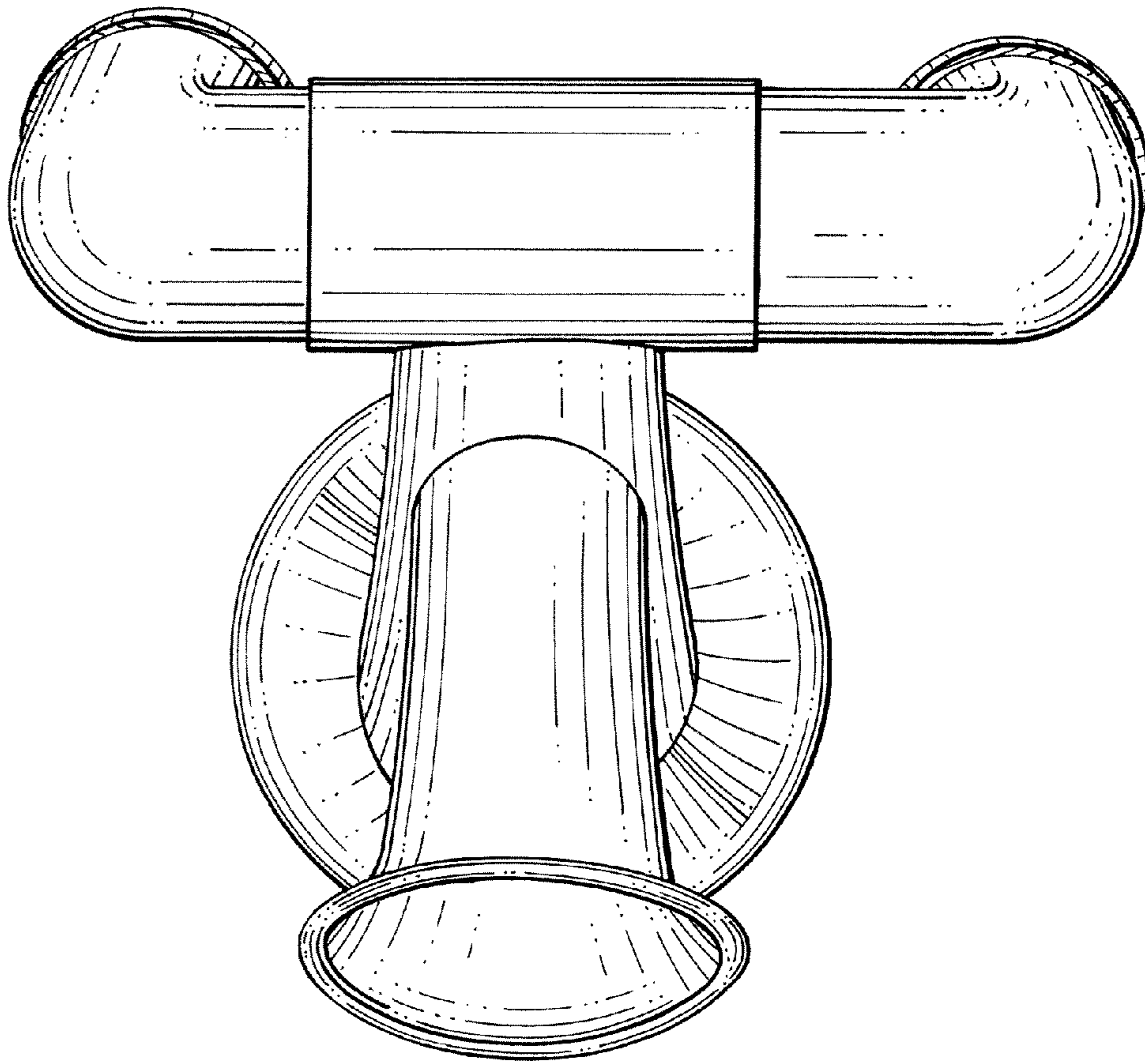

FIG. 7