



US00D708162S

(12) **United States Design Patent**
Wenger et al.

(10) **Patent No.:** **US D708,162 S**
(45) **Date of Patent:** **** Jul. 1, 2014**

- (54) **OVER-EAR HEADPHONES**
- (71) Applicant: **Grain Audio**, New York, NY (US)
- (72) Inventors: **Mitchell Wenger**, Denville, NJ (US);
Christopher Weir, Mill Valley, CA (US); **David Burke**, Effort, PA (US);
Kevin Schudde, Darien, CT (US)
- (73) Assignee: **Grain Audio, LLC**, New York, NY (US)

4,572,323	A *	2/1986	Randall	181/129
4,689,822	A *	8/1987	Houng	381/379
5,033,094	A *	7/1991	Hung	381/379
5,278,999	A *	1/1994	Brown et al.	2/209
D348,066	S *	6/1994	Lucey	D14/223
D354,958	S *	1/1995	Grasso et al.	D14/205
D379,817	S *	6/1997	Lin	D14/223
6,353,938	B1 *	3/2002	Young	2/209
D457,874	S *	5/2002	Yoneda	D14/205
6,611,963	B2 *	9/2003	Woo et al.	2/209
D560,654	S *	1/2008	Feng	D14/205
D563,382	S *	3/2008	Wikel	D14/205

(**) Term: **14 Years**

(Continued)

(21) Appl. No.: **29/446,667**

OTHER PUBLICATIONS

(22) Filed: **Feb. 26, 2013**

Press Release entitled: "Announcing a new line of our long-awaited first headphone—Muramasa VIII" (Mar. 7, 2012).

(51) **LOC (10) Cl.** **14-01**

(Continued)

(52) **U.S. Cl.**

CPC **H04S 1/005** (2013.01)

USPC **D14/205**

(58) **Field of Classification Search**

CPC H04S 1/005

USPC D14/205; D29/112; 2/209; 379/430,

379/431; 181/129, 130, 135; 381/371, 372,

381/374, 376, 379; 455/90.3, 575.1

See application file for complete search history.

Primary Examiner — Paula Greene

(74) *Attorney, Agent, or Firm* — McCarter & English, LLP

(57) **CLAIM**

What is claimed is an ornamental design for over-ear headphones, as shown and described.

DESCRIPTION

(56) **References Cited**

U.S. PATENT DOCUMENTS

2,437,049	A *	3/1948	Salisbury et al.	128/866
3,098,307	A *	7/1963	Caldwell, Jr.	434/185
D203,677	S *	2/1966	Spillman	D14/205
3,562,816	A *	2/1971	Hutchinson	2/209
D228,352	S *	9/1973	Itagaki	D14/205
3,952,158	A *	4/1976	Kyle et al.	381/72
D262,019	S *	11/1981	Upshaw	D14/205
4,471,496	A *	9/1984	Gardner et al.	2/209

FIG. 1 is a perspective view of over-ear headphones, including indicia that is shown in phantom lines and forms no part of the claimed design;

FIG. 2 is a front view of the headphones of FIG. 1;

FIG. 3 is a rear view of the headphones of FIG. 1;

FIG. 4 is a right side view of the headphones of FIG. 1;

FIG. 5 is a left side view of the headphones of FIG. 1;

FIG. 6 is a top view of the headphones of FIG. 1; and,

FIG. 7 is a bottom view of the headphones of FIG. 1.

1 Claim, 5 Drawing Sheets

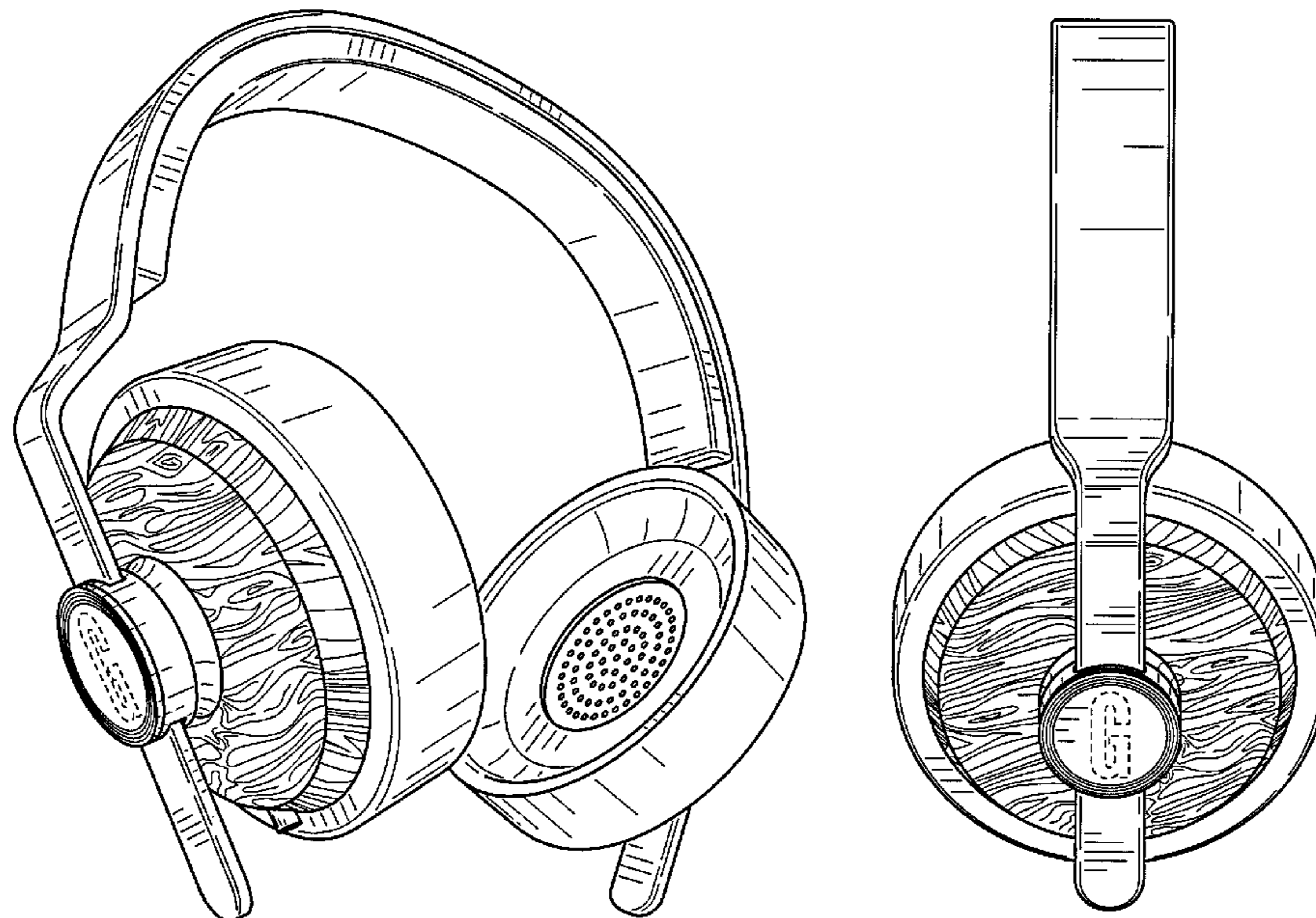

US D708,162 S

Page 2

(56)

References Cited

U.S. PATENT DOCUMENTS

D620,474 S * 7/2010 Komiyama D14/205
D663,717 S * 7/2012 Hutchieson D14/206
D673,929 S * 1/2013 Combs et al. D14/205
D678,241 S * 3/2013 Lee et al. D14/205
D684,559 S * 6/2013 Groset et al. D14/205
D686,593 S * 7/2013 Larsen D14/205

D690,282 S * 9/2013 Lee et al. D14/205
D691,108 S * 10/2013 Takeno D14/205
2013/0153328 A1* 6/2013 Carolan et al. 181/129

OTHER PUBLICATIONS

Press Release by Incase Audio entitled: "Coming Fall 2011: Incase Audio: Natural sound. Minimal design" (Fall 2011).

* cited by examiner



FIG. 1

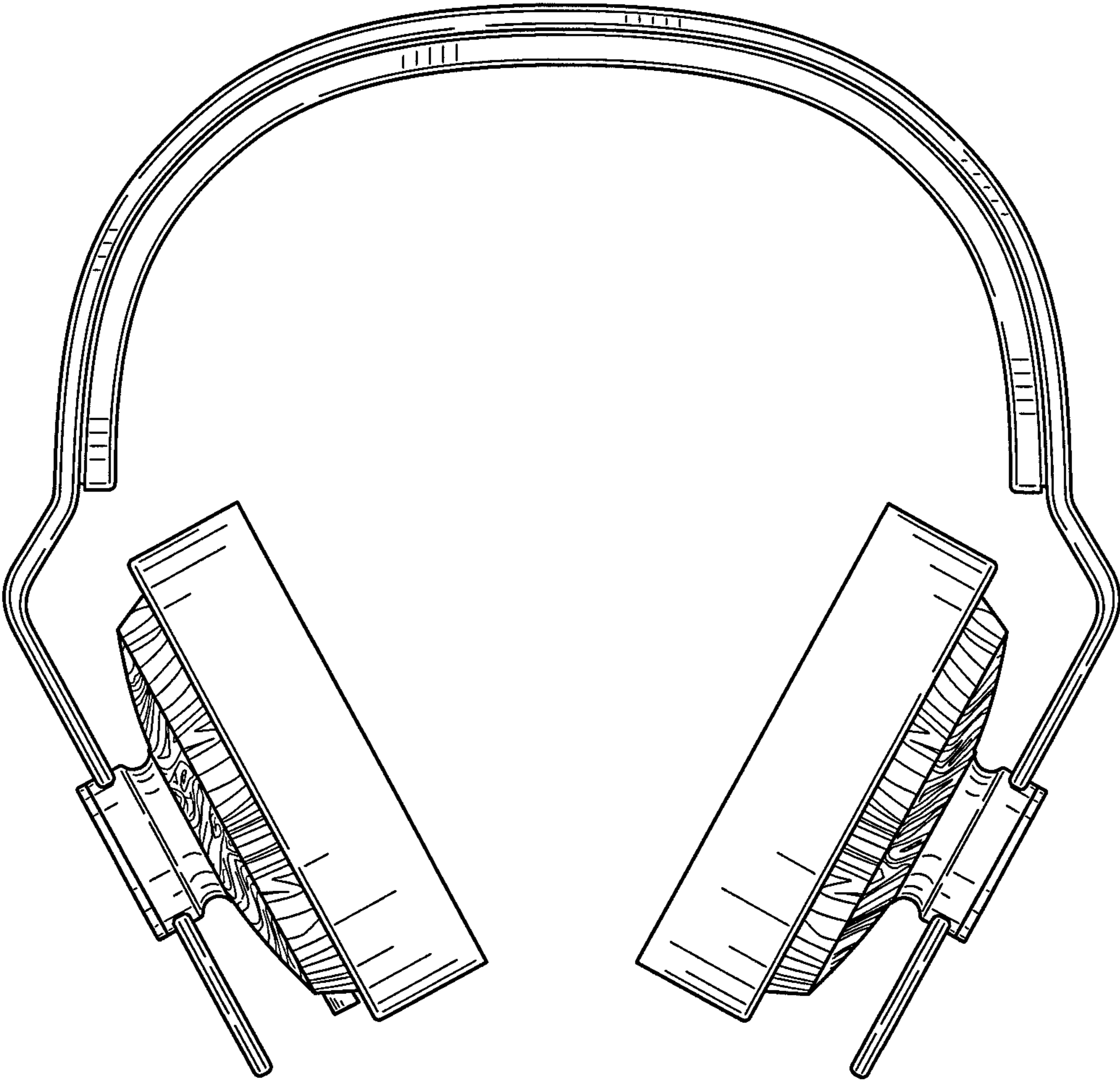

FIG. 2

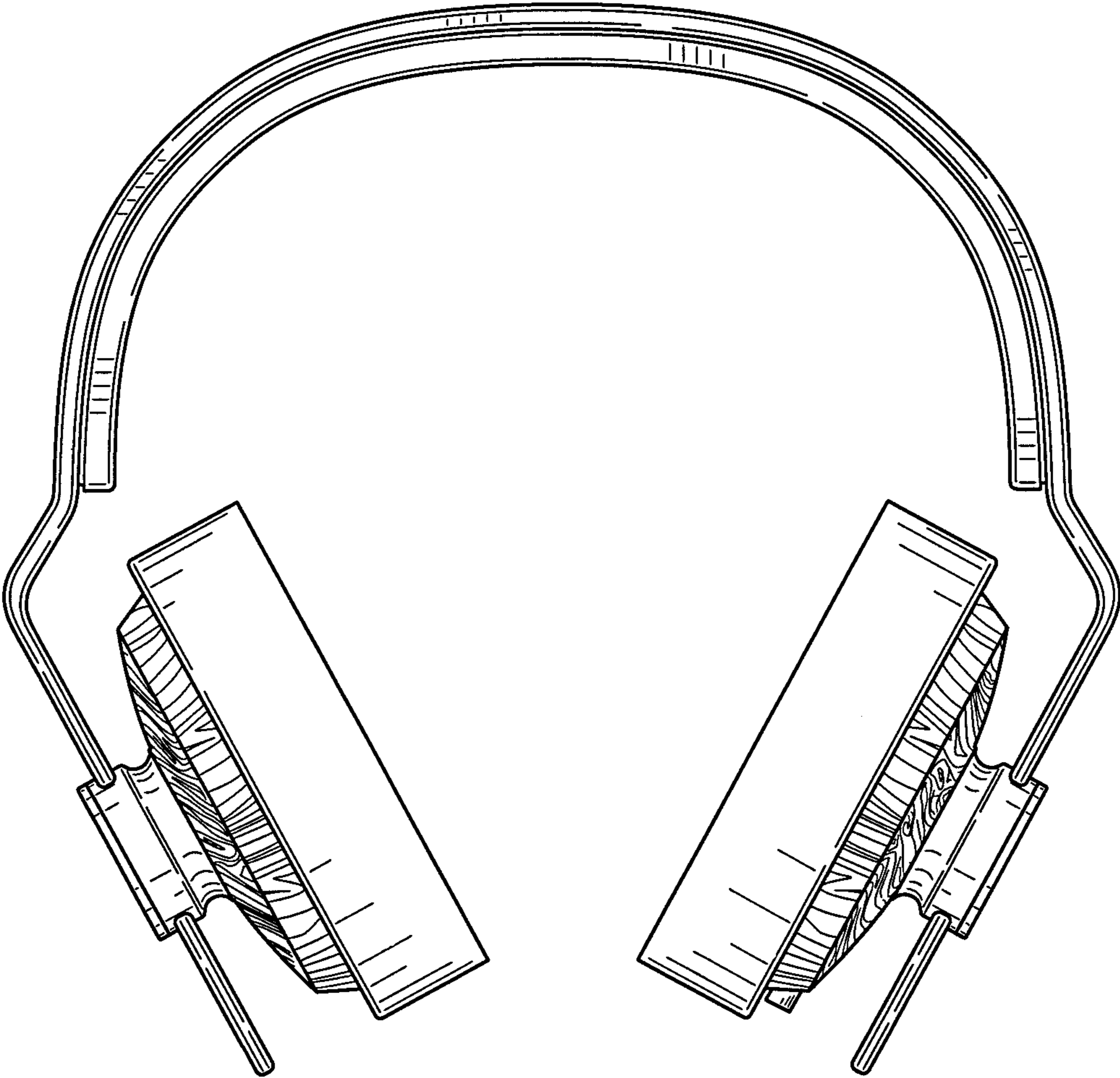

FIG. 3

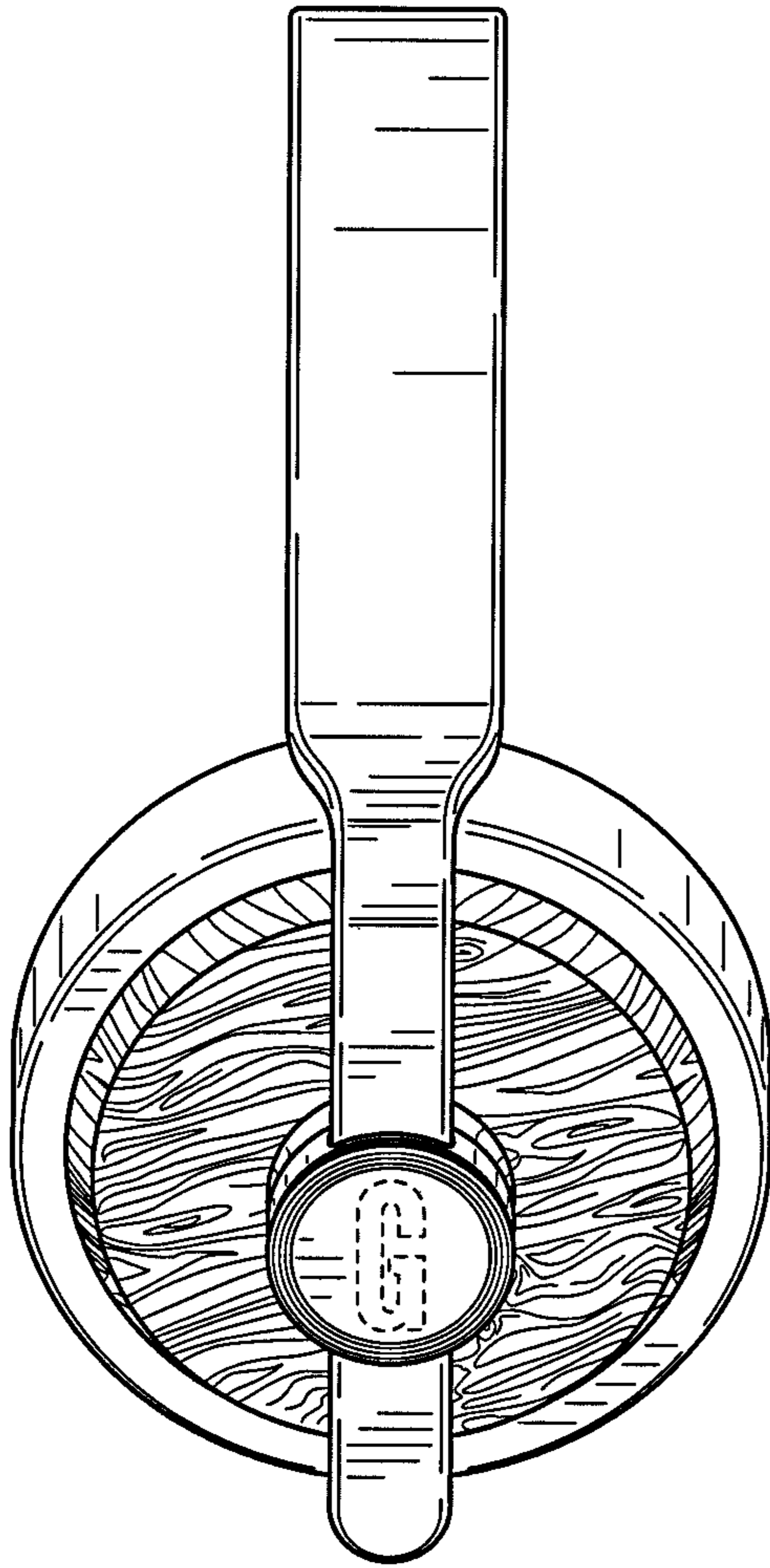

FIG. 4

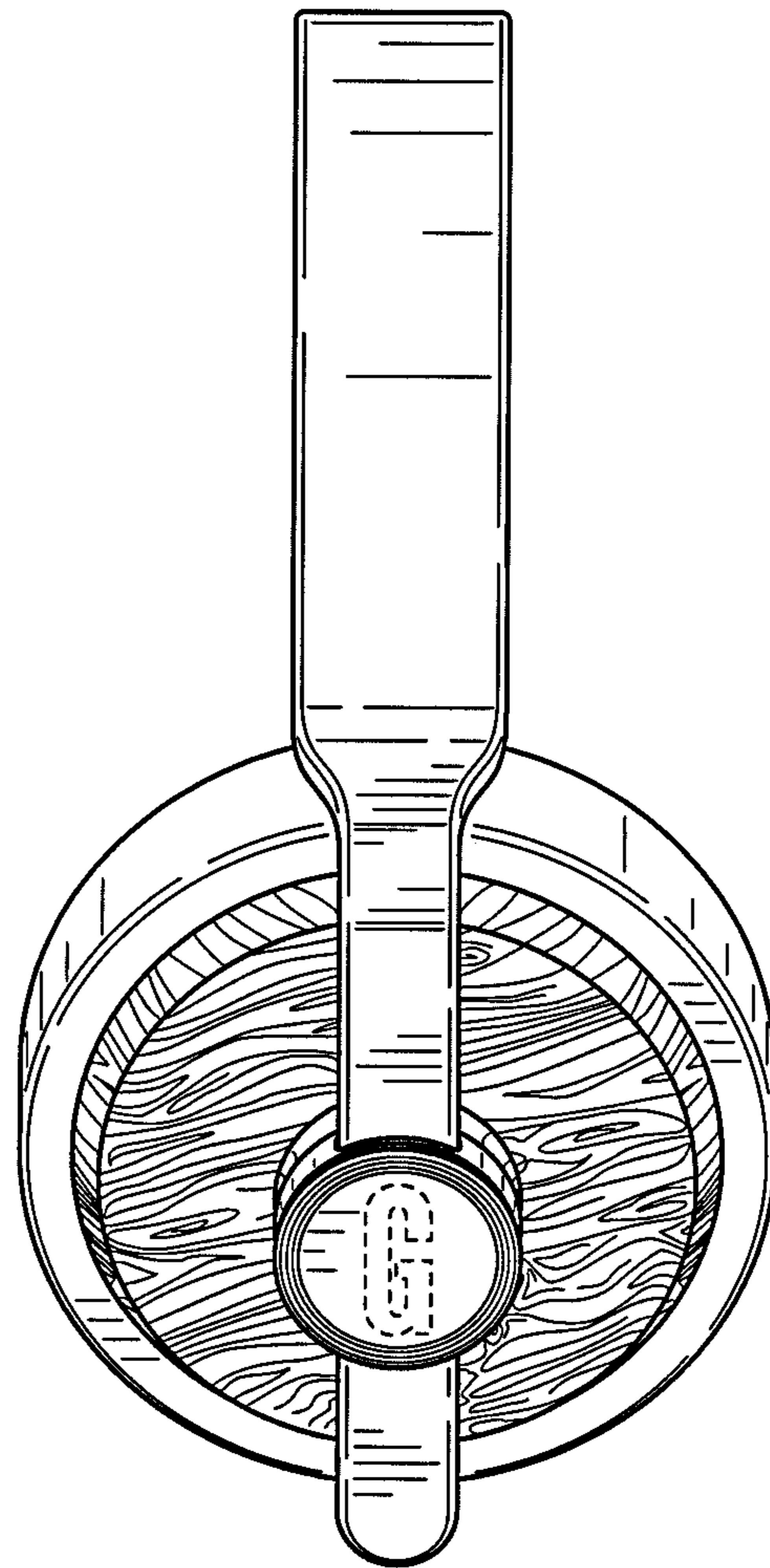

FIG. 5

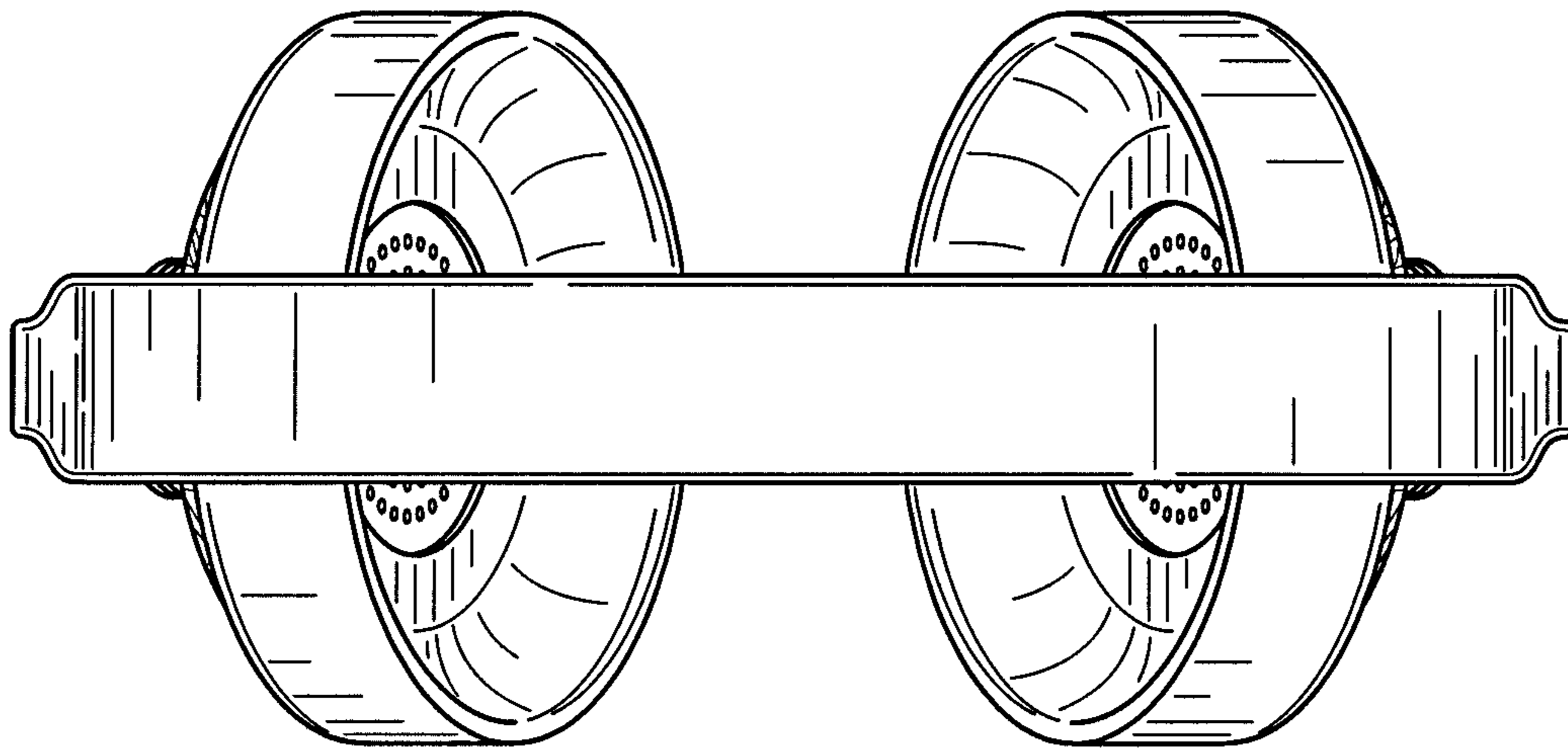

FIG. 6

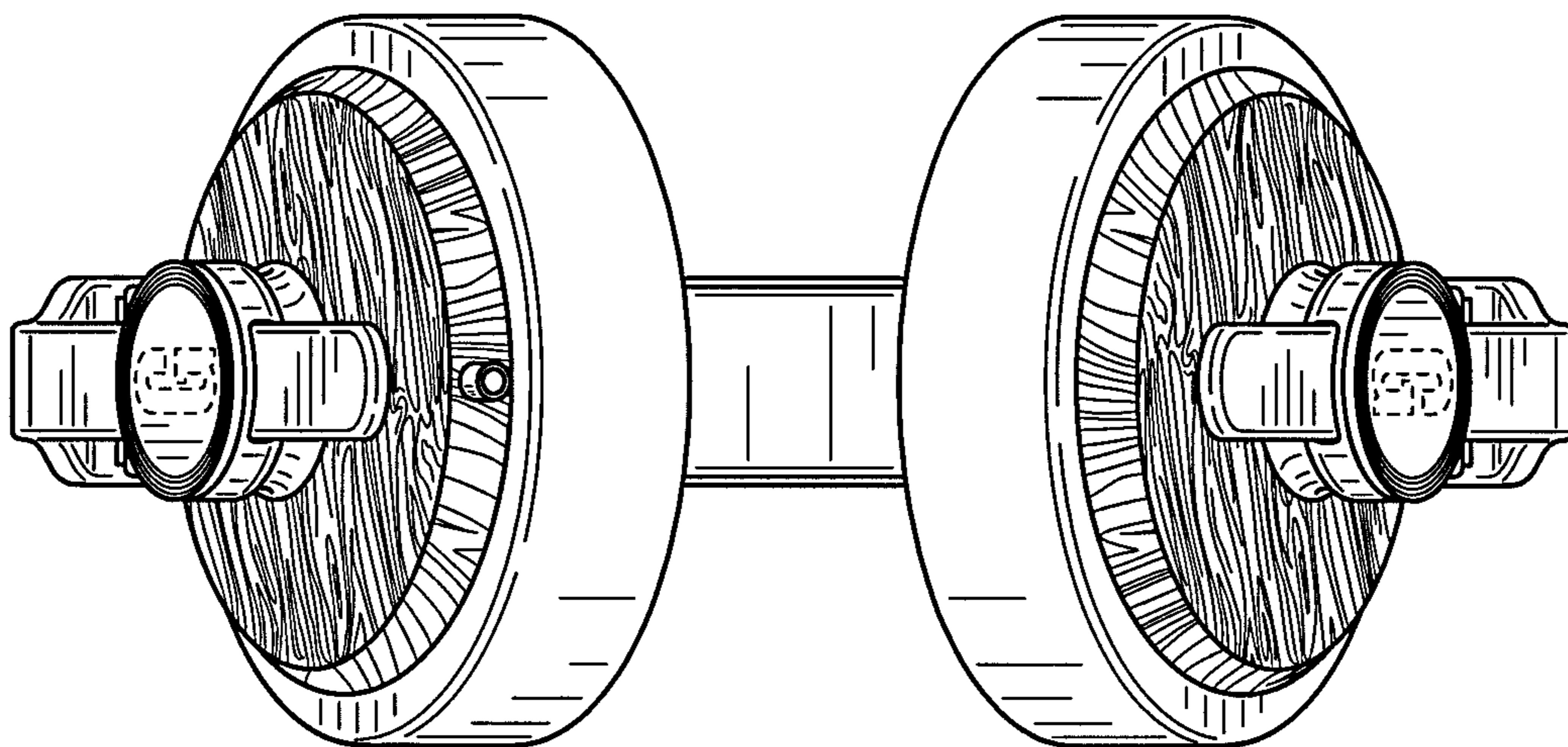

FIG. 7