



US00D708115S

(12) **United States Design Patent**
Graven

(10) **Patent No.:** **US D708,115 S**

(45) **Date of Patent:** **** Jul. 1, 2014**

(54) **COMBINED ATV AND JET SKI**

(76) **Inventor:** **David C. Graven, Houston, TX (US)**

(**) **Term:** **14 Years**

(21) **Appl. No.:** **29/396,016**

(22) **Filed:** **Jun. 24, 2011**

(51) **LOC (10) Cl.** **12-06**

(52) **U.S. Cl.**
USPC **D12/307**

(58) **Field of Classification Search**
USPC D12/2, 3, 300, 307, 317; 114/55.5,
114/55.55, 55.57, 162, 219, 270, 271, 343,
114/344; 440/11, 12, 12.5, 12.51, 12.52,
440/12.63, 12.64; 180/9.1
See application file for complete search history.

5,687,669	A	11/1997	Engler	
6,062,156	A	5/2000	Radke et al.	
6,095,275	A	8/2000	Shaw	
6,505,694	B2 *	1/2003	Maguire	180/9.1
6,595,812	B1	7/2003	Haney	
6,698,782	B2	3/2004	Bouchard	
D505,907	S *	6/2005	Bryham	D12/300
6,921,304	B2 *	7/2005	Hewitt	440/12.52
D522,441	S *	6/2006	Bryham	D12/307
7,077,714	B2	7/2006	Brown	
7,753,155	B2	7/2010	Snyder et al.	
2003/0155739	A1	8/2003	Morin	

* cited by examiner

Primary Examiner — Cynthia M Chin

(74) *Attorney, Agent, or Firm* — RG Patent Consulting LLC

(57) **CLAIM**

I claim the ornamental design for a combined ATV and jet ski, as shown and described.

(56) **References Cited**

U.S. PATENT DOCUMENTS

1,002,661	A *	9/1911	Erickson	114/344
3,080,581	A *	3/1963	Smihal	114/343
3,474,751	A	10/1969	Hebert	
3,521,595	A	7/1970	Mix	
3,646,904	A	3/1972	Lanning et al.	
3,826,216	A	7/1974	Rhody	
3,853,085	A	12/1974	Halboth	
4,706,769	A	11/1987	Latourelle et al.	
4,712,636	A *	12/1987	Ishimatsu	114/344
D297,825	S *	9/1988	Duff	D12/3
D305,877	S *	2/1990	Price, II	D12/3
5,176,098	A *	1/1993	Royle	114/344
5,400,734	A	3/1995	Doyon	
5,682,832	A	11/1997	Millard	

DESCRIPTION

FIG. 1 is a front, top and side perspective view of the combined ATV and jet ski embodying the design of the present invention.

FIG. 2 is a side elevational view thereof, the side opposite to the side shown in FIG. 2 being a mirror image thereof.

FIG. 3 is a top plan view thereof.

FIG. 4 is a bottom plan view thereof.

FIG. 5 is a front elevational view thereof; and,

FIG. 6 is a rear elevational view thereof.

The broken lines represent portions of the article that form no part of the claim.

1 Claim, 4 Drawing Sheets

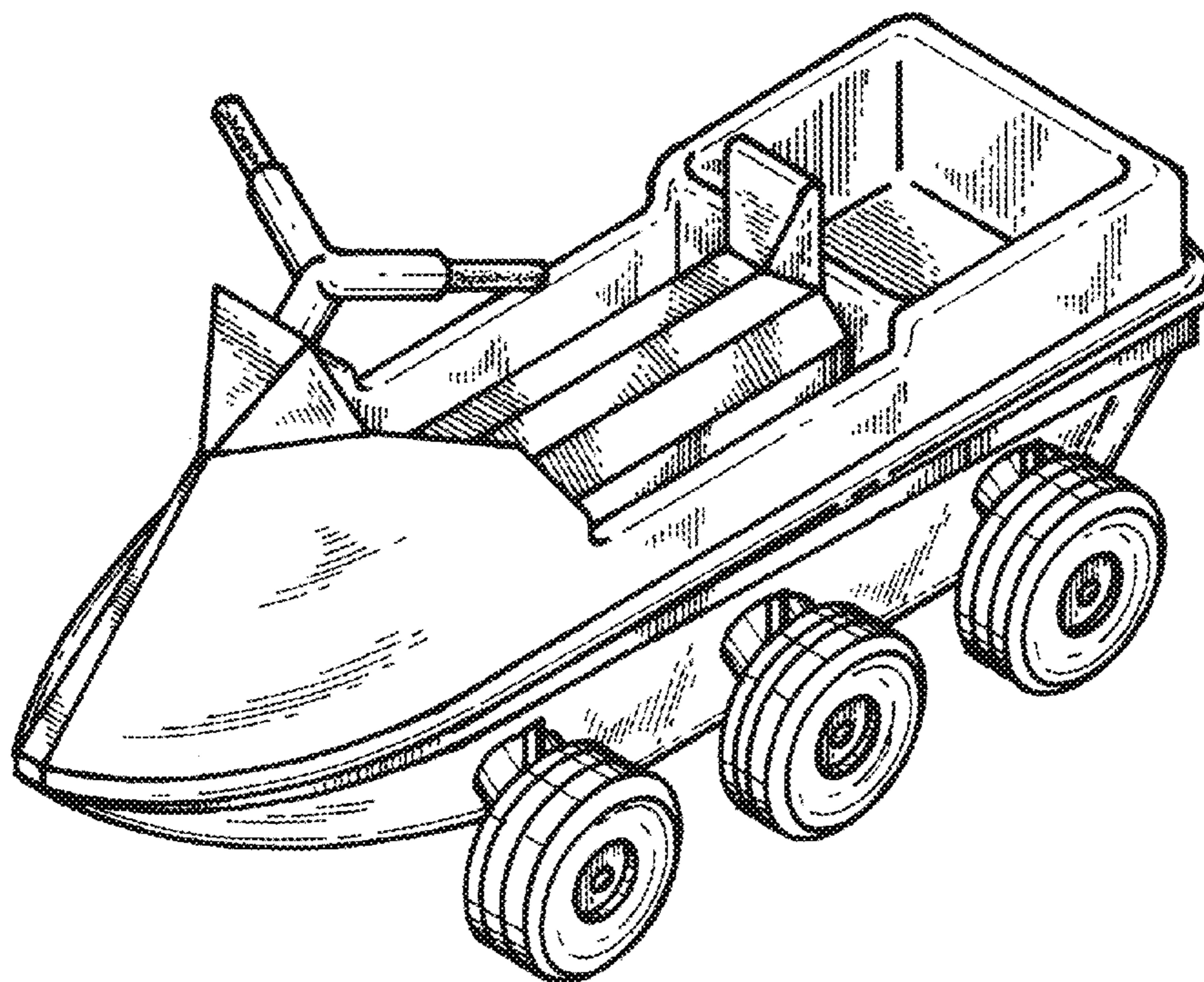

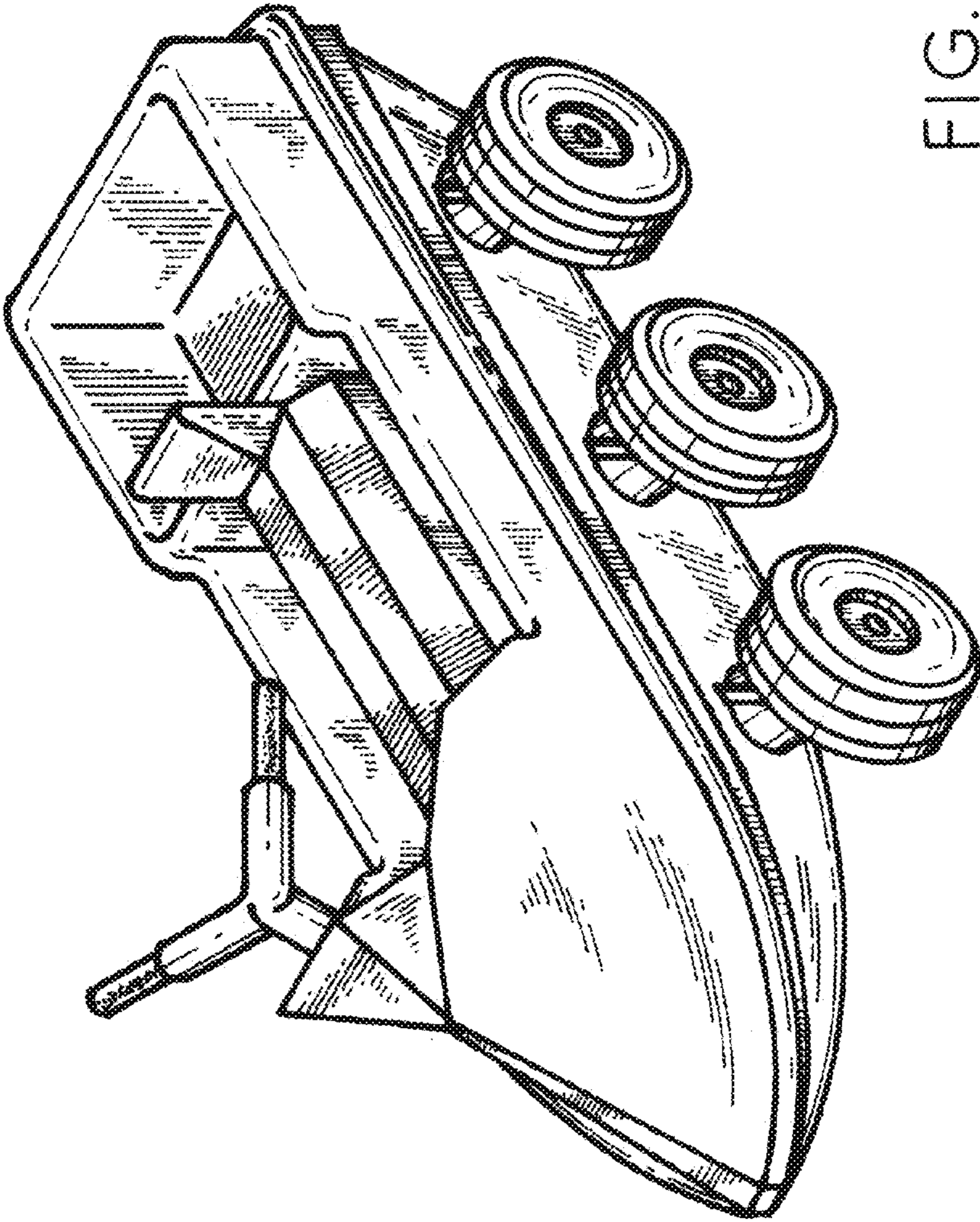

FIG. 1

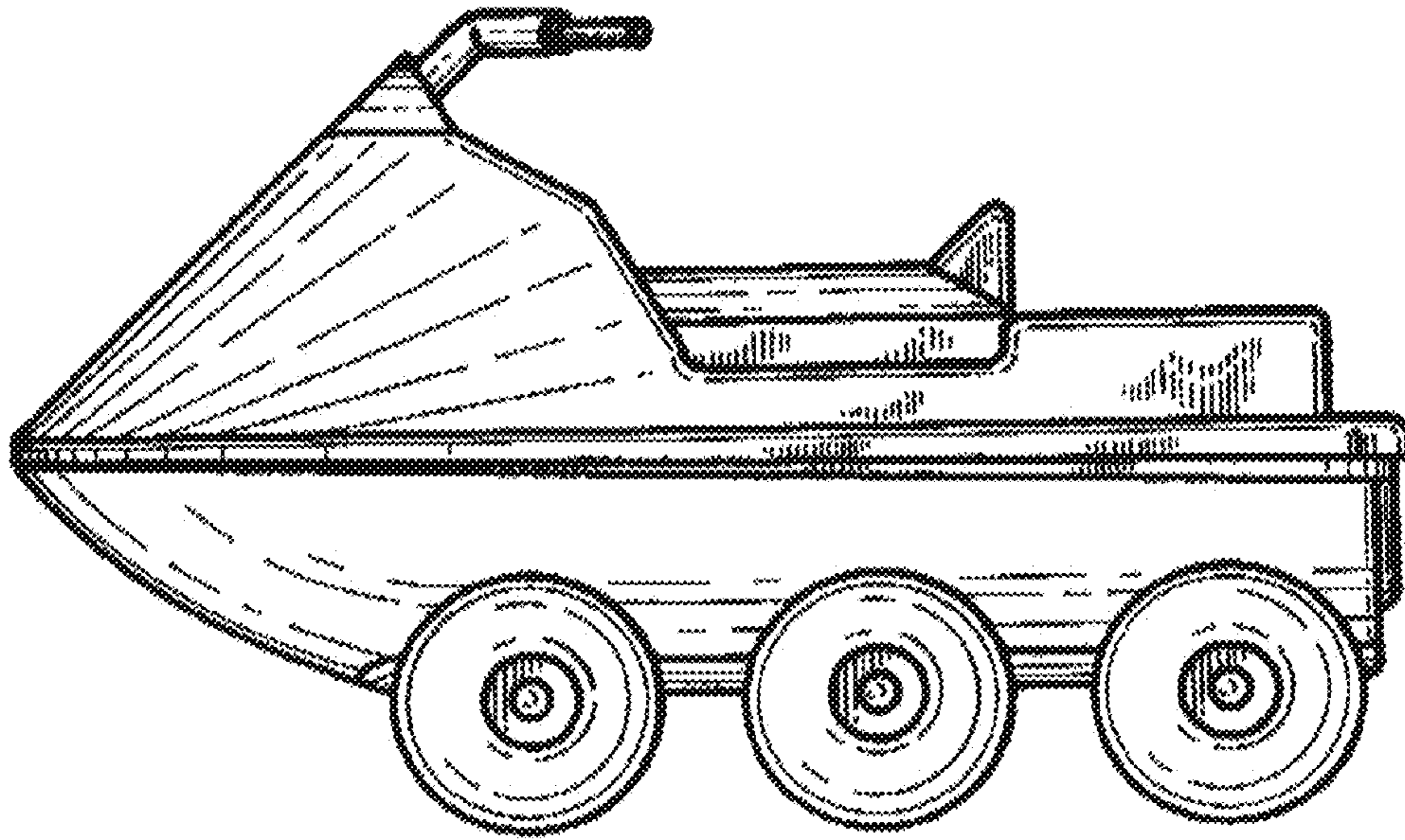

FIG. 2

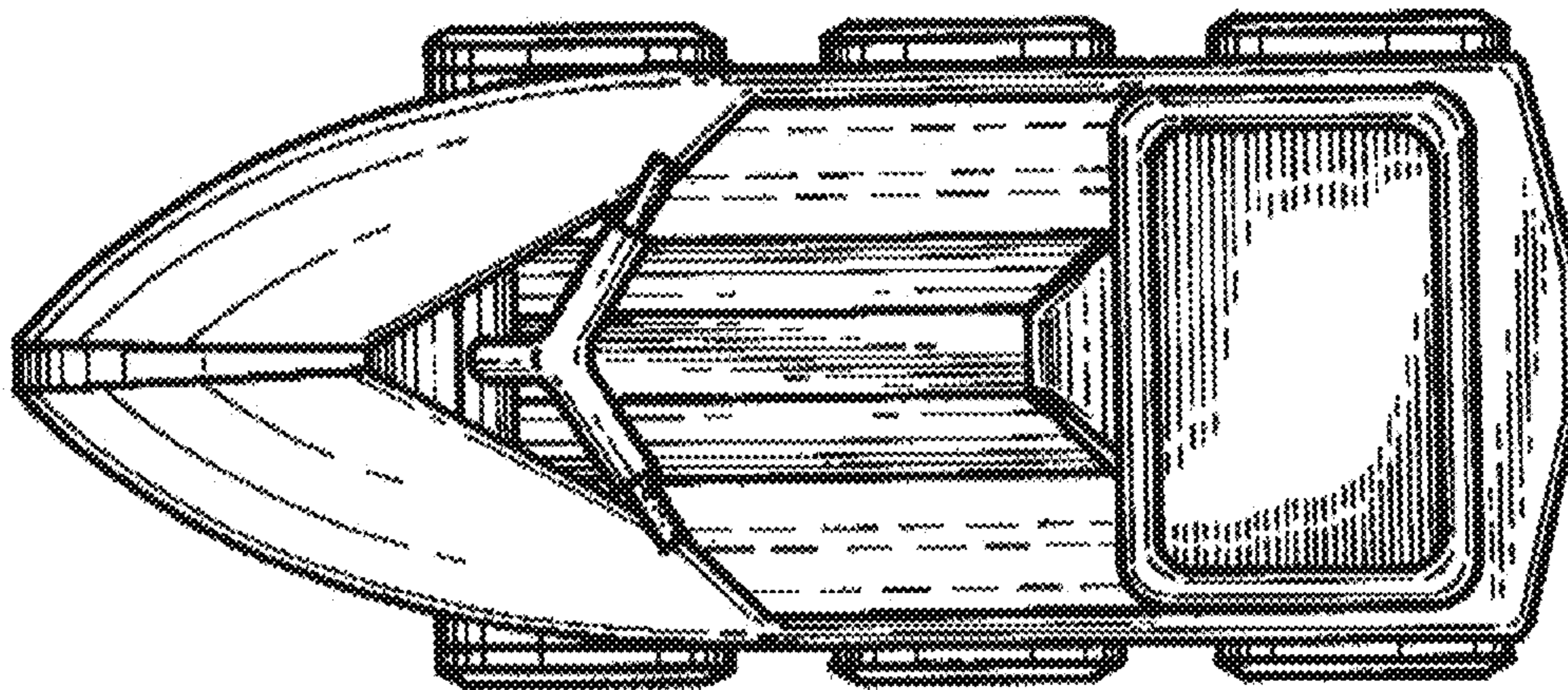

FIG. 3

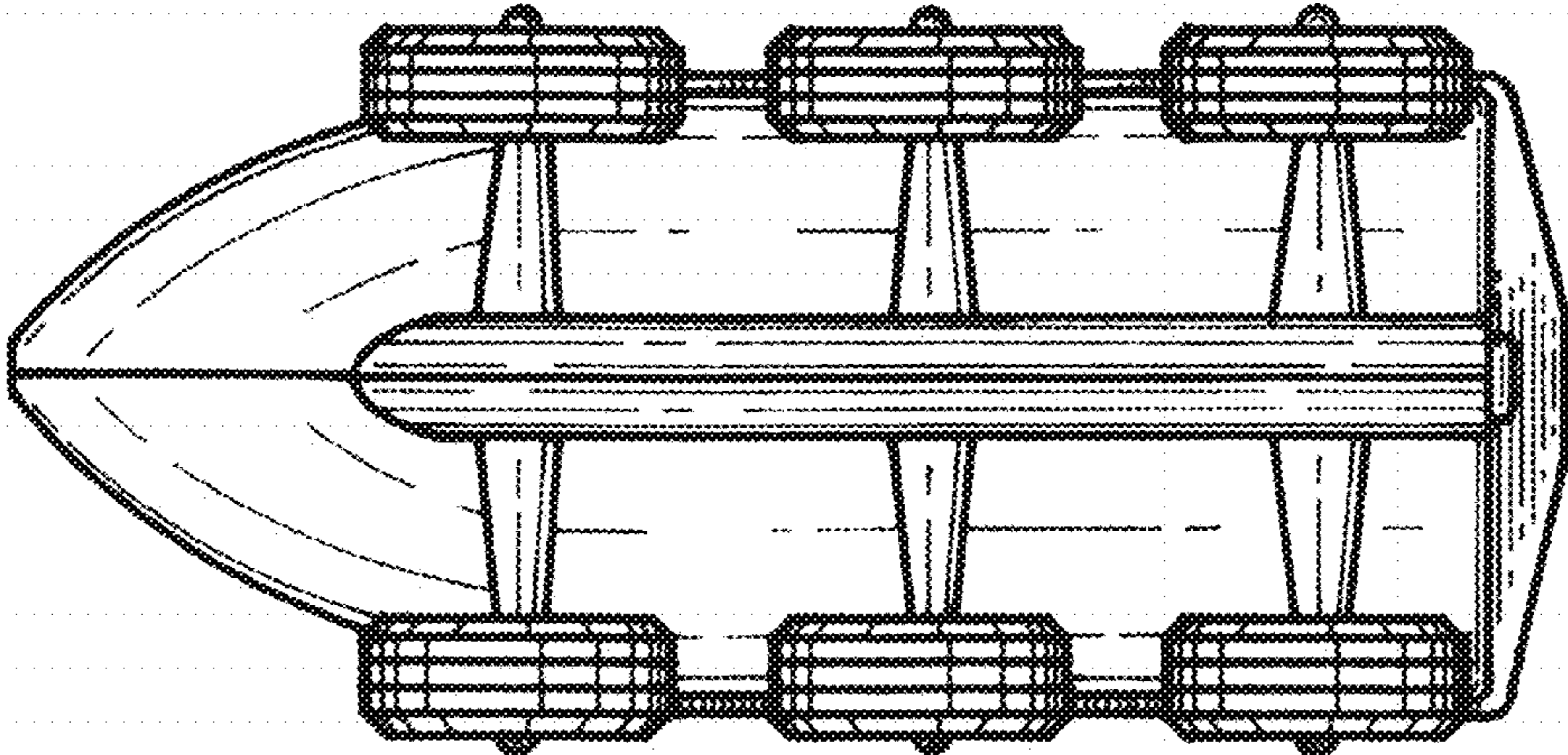

FIG. 4

FIG. 5

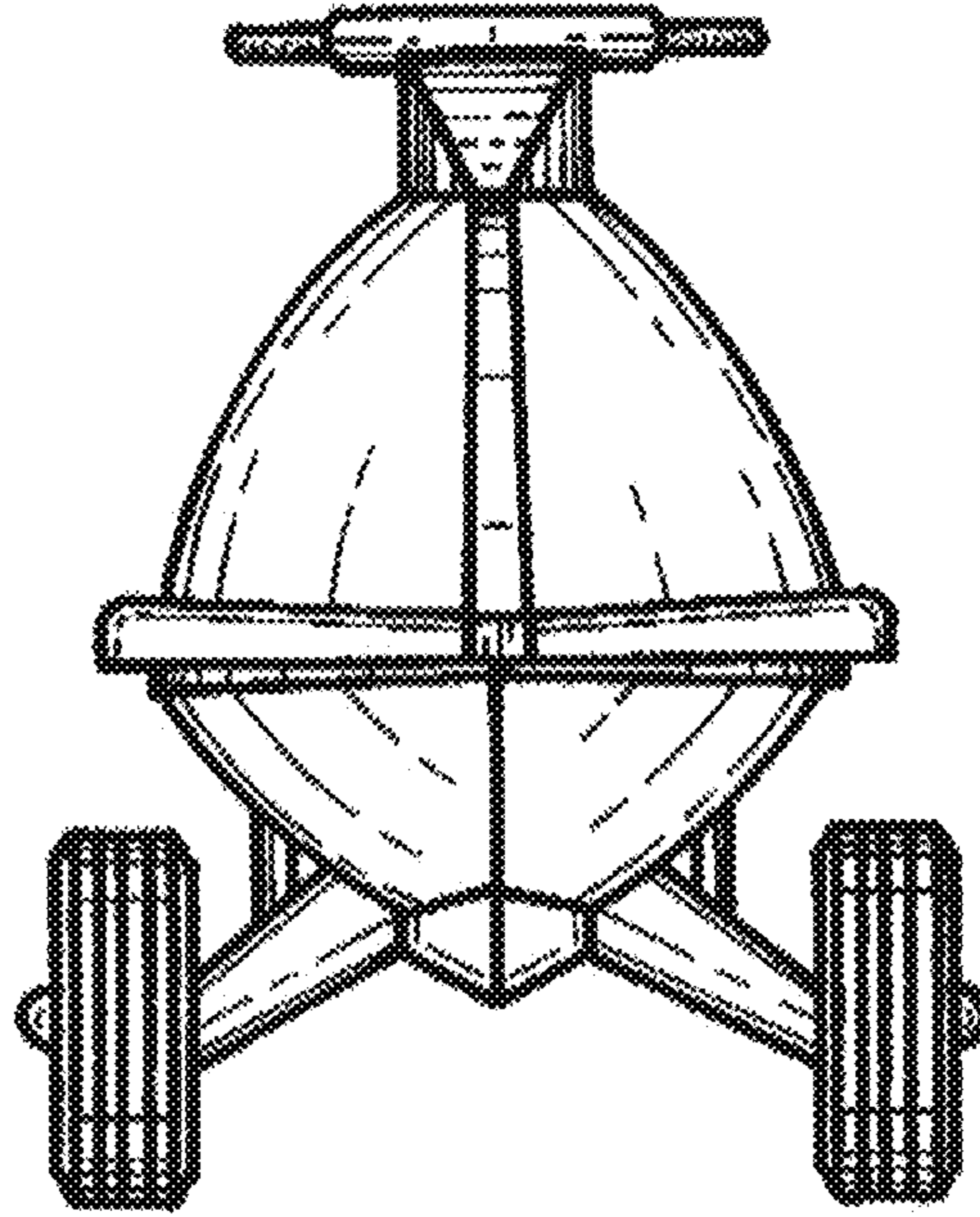

FIG. 6

