



US00D707608S

(12) **United States Design Patent**
Smith

(10) **Patent No.:** **US D707,608 S**
(45) **Date of Patent:** **** Jun. 24, 2014**

(54) **FORWARD SWEPT CAB**

(71) Applicant: **Jeffrey P. Smith**, Prosper, TX (US)

(72) Inventor: **Jeffrey P. Smith**, Prosper, TX (US)

(73) Assignee: **PACCAR Inc**, Bellevue, WA (US)

(**) Term: **14 Years**

(21) Appl. No.: **29/449,252**

(22) Filed: **Mar. 14, 2013**

(51) **LOC (10) Cl.** **12-16**

(52) **U.S. Cl.**

USPC **D12/196**; D12/181

(58) **Field of Classification Search**

CPC B62D 25/06; B62D 27/26; B62D 33/06;
B62D 35/01; B62D 65/02

USPC D12/88, 94, 95, 96, 181, 184, 190, 191,
D12/196, 400; 280/727, 762, 770, 848;
296/91, 180.1, 180.2, 190.2, 217, 225;
180/903; D15/11, 17, 28; D21/561,
D21/562

See application file for complete search history.

(56) **References Cited**

U.S. PATENT DOCUMENTS

| | | | | |
|-----------|------|---------|-------------------|-----------|
| 4,957,322 | A * | 9/1990 | Marlowe et al. | 296/180.2 |
| D311,506 | S * | 10/1990 | Marlowe et al. | D12/96 |
| D343,819 | S * | 2/1994 | Meryman et al. | D12/181 |
| 5,458,392 | A * | 10/1995 | Chen et al. | 296/180.2 |
| 5,603,549 | A * | 2/1997 | Chen et al. | 296/180.1 |
| D425,450 | S * | 5/2000 | Barracough et al. | D12/96 |
| D436,894 | S * | 1/2001 | Barracough et al. | D12/96 |
| 6,217,107 | B1 * | 4/2001 | Langlois | 296/180.2 |
| D475,657 | S * | 6/2003 | Wong et al. | D12/96 |
| D633,015 | S * | 2/2011 | Peltola et al. | D12/181 |
| D657,717 | S * | 4/2012 | Stimel, Jr. | D12/96 |
| D666,541 | S * | 9/2012 | Stimel, Jr. | D12/181 |
| D686,123 | S * | 7/2013 | Peltola et al. | D12/181 |

FOREIGN PATENT DOCUMENTS

JP 2003072598 A * 3/2003 B62D 35/00
JP 2012136121 A * 7/2012 B62D 35/00

OTHER PUBLICATIONS

Freightliner Cascadia XT Sleeper. Electronic Brochure. Aug. 14, 2012 [online], [retrieved on Jan. 26, 2014]. Retrieved from the Internet <URL: <http://www.lafreightliner.com/Source/PDF/newtrucks/cascadiaXTsleeper.pdf>>.*

Freightliner Cascadia Evolution: The Science of Innovation. Electronic Brochure. Mar. 15, 2012 [online], [retrieved on Jan. 26, 2014]. Retrieved from the Internet <URL: <http://www.lafreightliner.com/Evolution/freightliner%20evolution.pdf>>.*

* cited by examiner

Primary Examiner — Philip S Hyder

Assistant Examiner — Darlington Ly

(74) *Attorney, Agent, or Firm* — Christensen O'Connor Johnson Kindness PLLC

(57) **CLAIM**

The ornamental design for a forward swept cab, as shown and described.

DESCRIPTION

FIG. 1 is a perspective view of a forward swept cab according to my new design;

FIG. 2 is a top view of the forward swept cab of FIG. 1;

FIG. 3 is a front view of the forward swept cab of FIG. 1;

FIG. 4 is a side view of the forward swept cab taken from the right side of FIG. 1; and,

FIG. 5 is a side view of the forward swept cab taken from the left side of FIG. 1.

The rear of the forward swept cab is unornamented.

The broken lines immediately adjacent the shaded areas as depicted in the FIGURES, represent the bounds of the claimed design while all other broken lines are directed to environment and are for illustrative purposes only; the broken lines form no part of the claimed design.

1 Claim, 5 Drawing Sheets

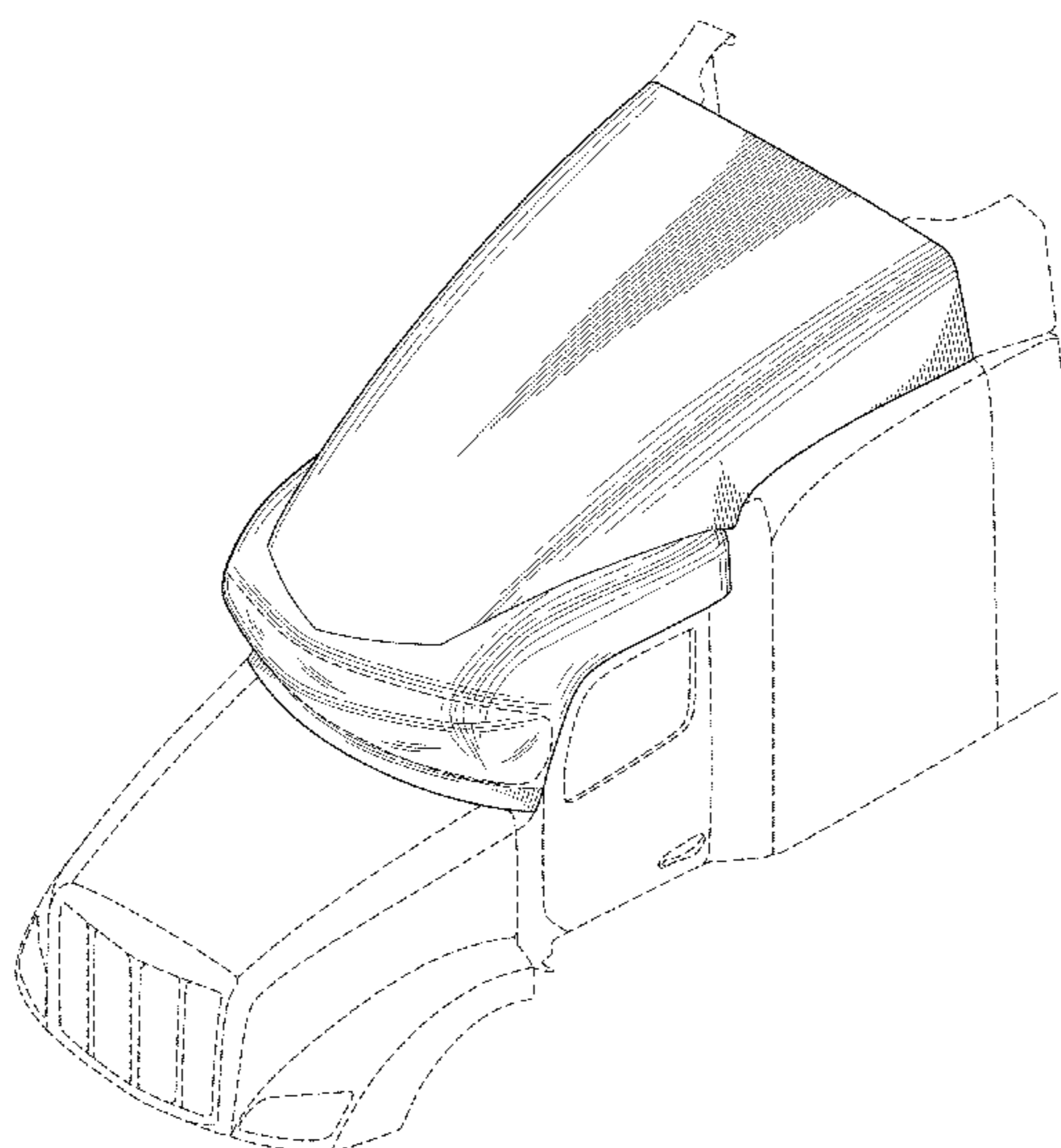
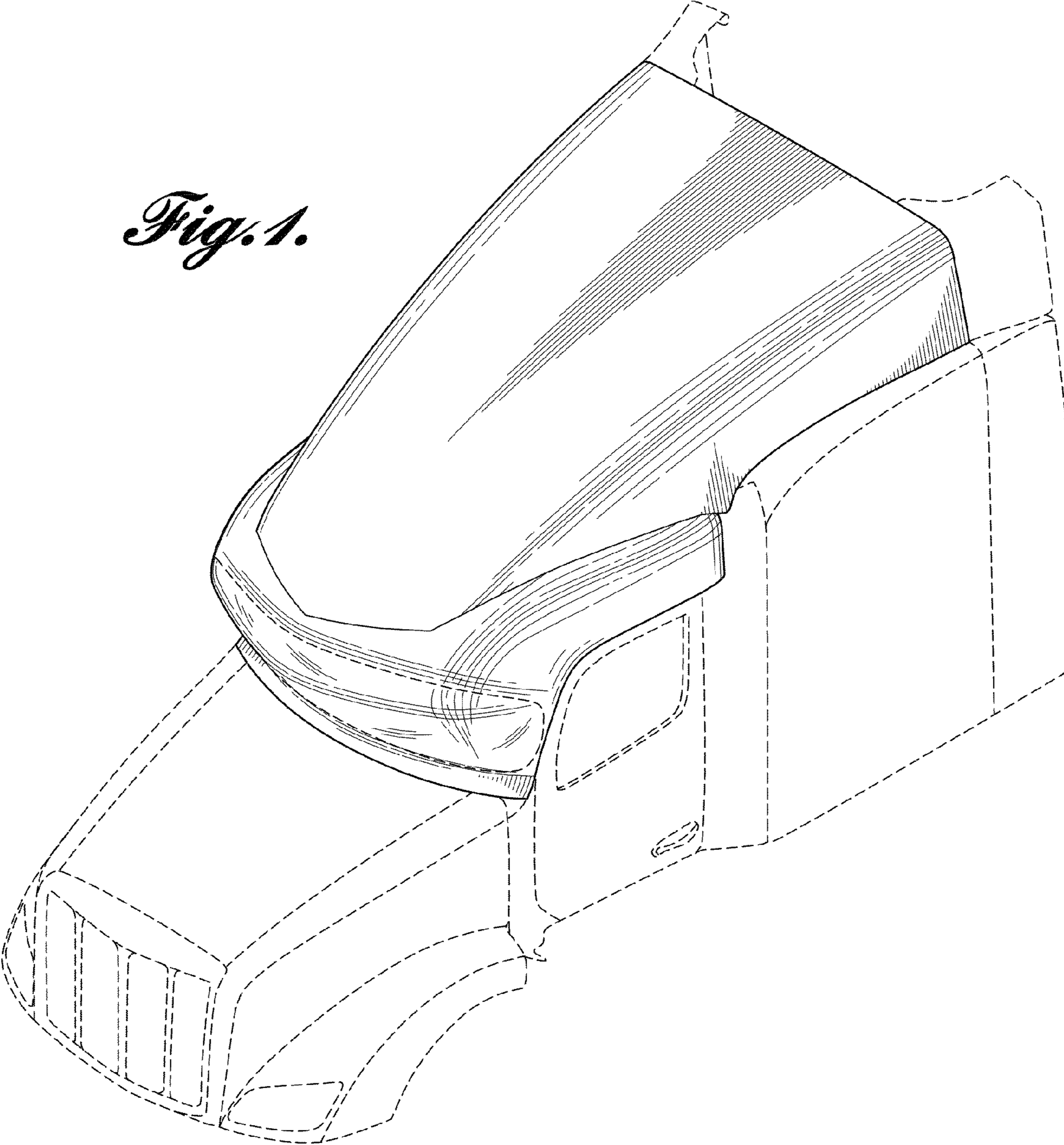

Fig. 1.



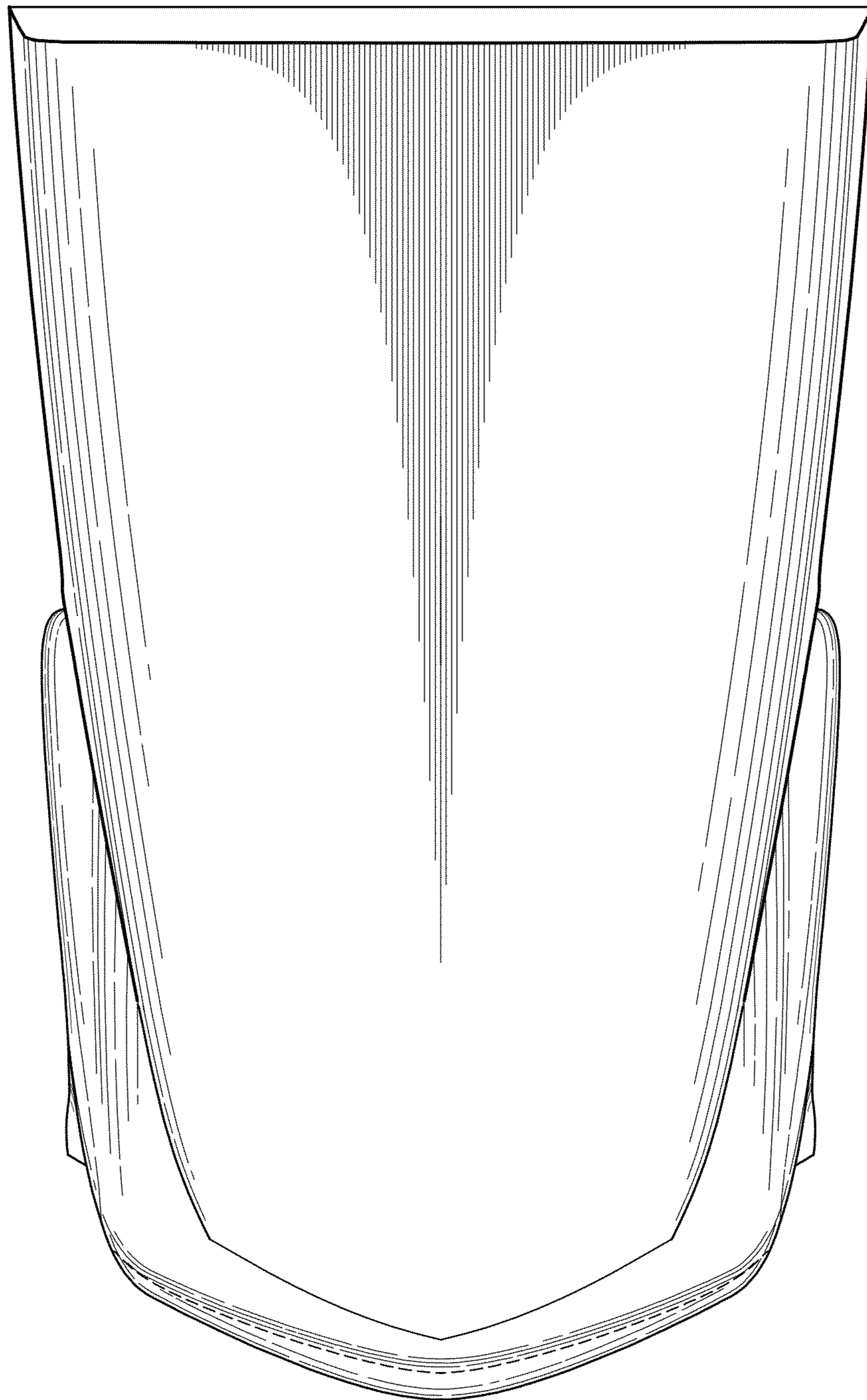

Fig. 2.

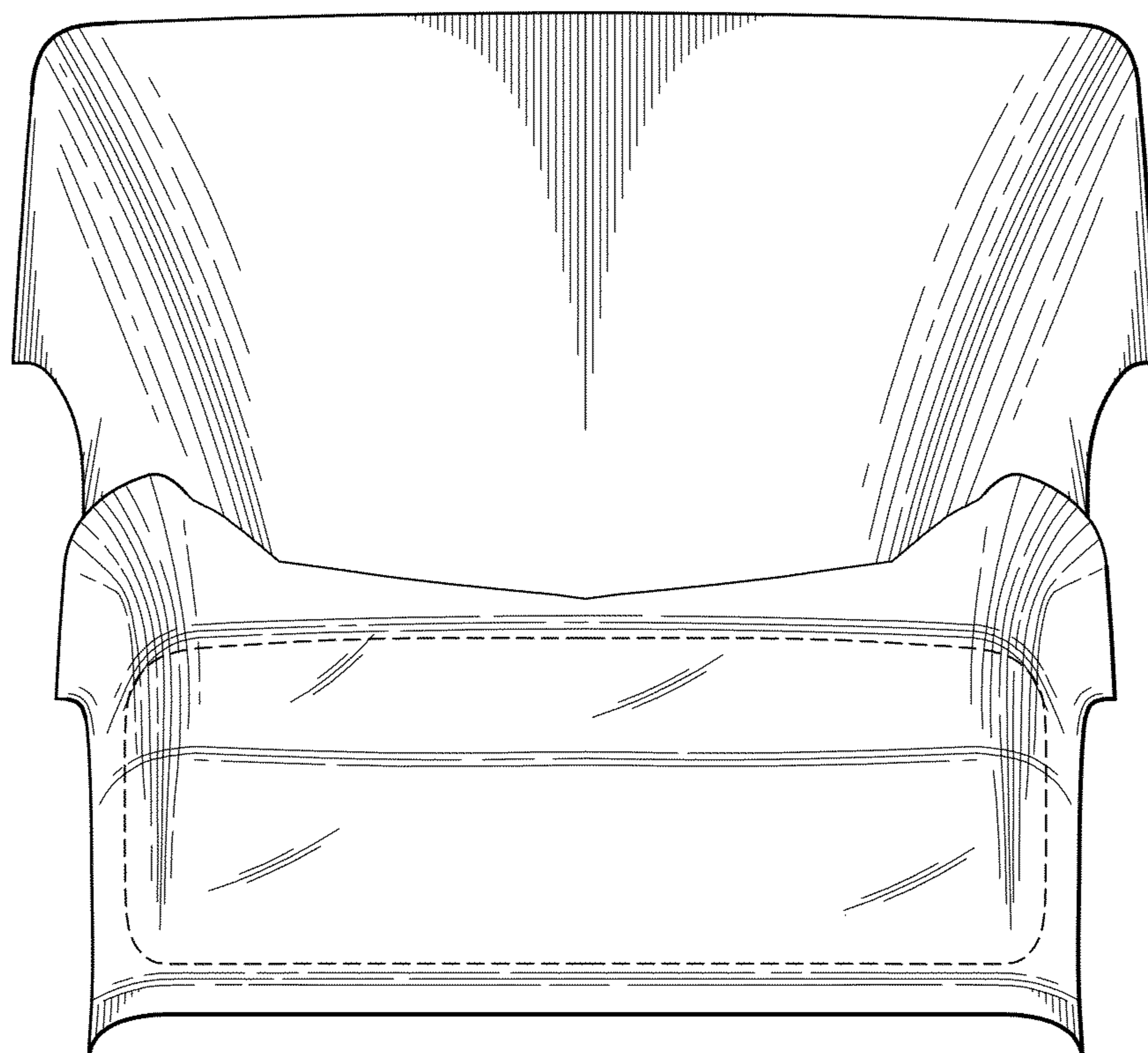

Fig. 3.

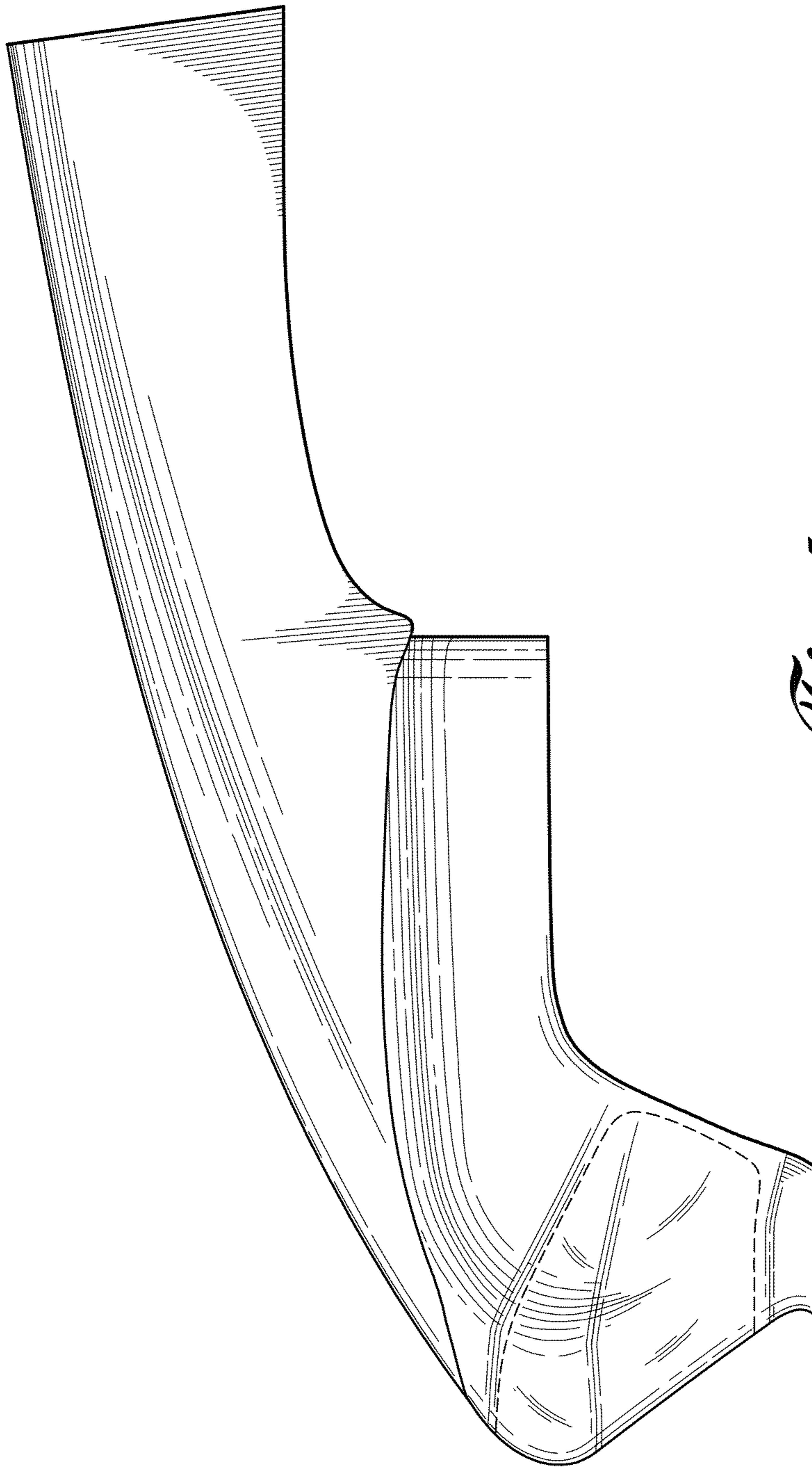

Fig. 4.

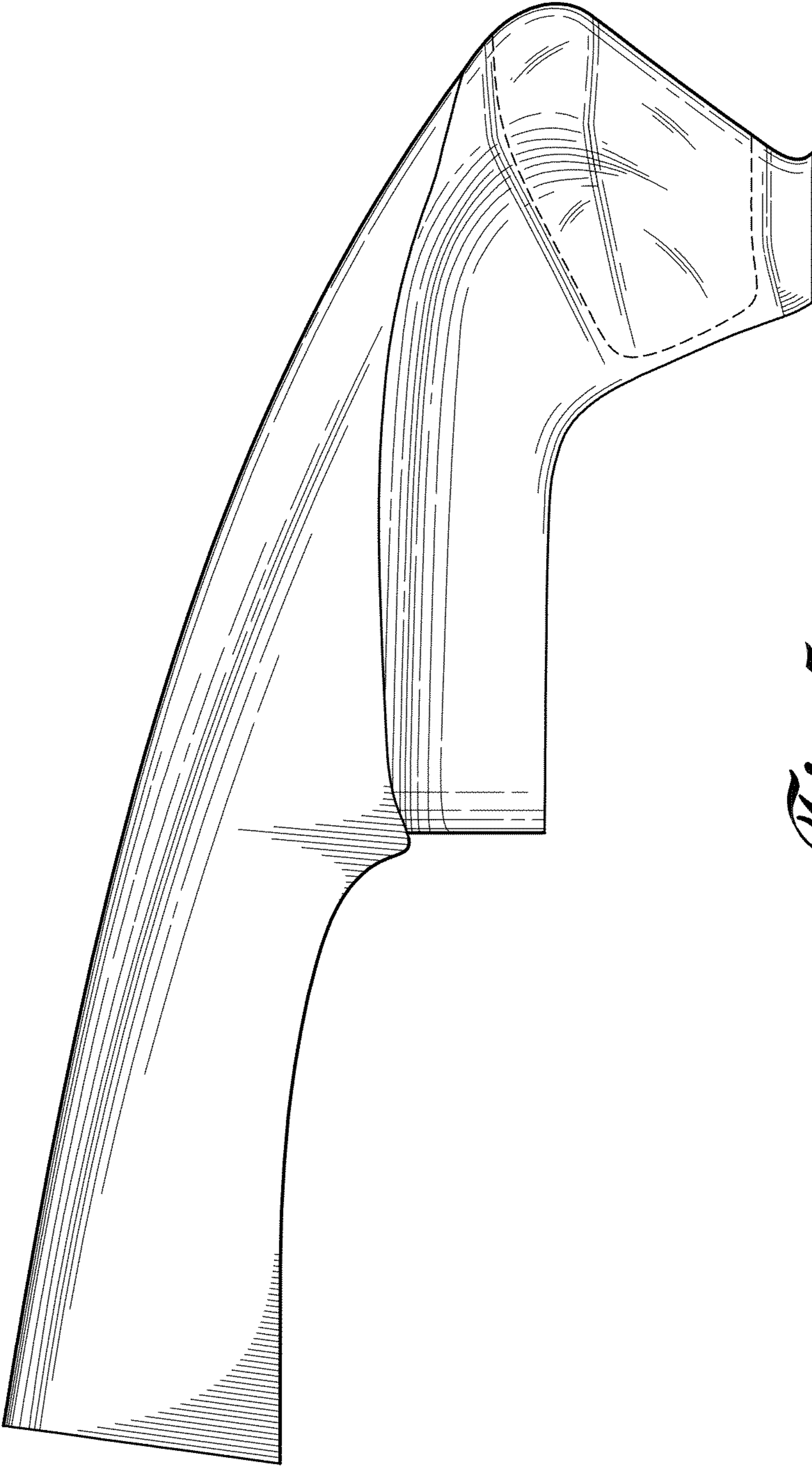

Fig. 5.