

US00D707387S

(12) **United States Design Patent**  
**Stolte et al.**

(10) **Patent No.:** **US D707,387 S**  
(45) **Date of Patent:** **\*\* Jun. 17, 2014**

(54) **LIGHTING FIXTURE**

(71) Applicant: **Kenall Manufacturing Company**,  
Gurnee, IL (US)

(72) Inventors: **Brandon Stolte**, Lindenhurst, IL (US);  
**Kevin Dahlen**, Lindenhurst, IL (US);  
**James Hawkins**, Lake Bluff, IL (US)

(73) Assignee: **Kenall Manufacturing Company**,  
Gurnee, IL (US)

(\*\*) Term: **14 Years**

(21) Appl. No.: **29/464,699**

(22) Filed: **Aug. 20, 2013**

**Related U.S. Application Data**

(63) Continuation of application No. 13/005,288, filed on  
Jan. 12, 2011.

(51) **LOC (10) Cl.** ..... **26-99**

(52) **U.S. Cl.**  
USPC ..... **D26/142**

(58) **Field of Classification Search**  
USPC ..... D26/72, 85, 89, 119, 128; 362/147,  
362/350, 404-408, 453-456  
See application file for complete search history.

(56) **References Cited**

**U.S. PATENT DOCUMENTS**

4,729,076	A	3/1988	Masami et al.	
D393,093	S *	3/1998	Fiorato	D26/85
D443,713	S *	6/2001	Benensohn	D26/72
D464,164	S *	10/2002	Thompson	D26/89
D465,599	S *	11/2002	Thompson	D26/89
D535,051	S *	1/2007	Stauffer	D26/128
D571,034	S *	6/2008	Goetz-Schaefer	D26/85
D583,091	S *	12/2008	Benensohn	D26/89
7,593,229	B2	9/2009	Shuy	
7,604,380	B2	10/2009	Burton et al.	
7,611,264	B1 *	11/2009	Chang et al.	362/249.02
D607,600	S *	1/2010	Keith	D26/85
7,682,055	B2	3/2010	Shuai et al.	
7,712,925	B2	5/2010	Russell	

7,775,692	B2	8/2010	Li	
7,810,965	B2	10/2010	Weaver	
7,828,465	B2	11/2010	Roberge et al.	
7,832,898	B2	11/2010	Li	
D628,738	S *	12/2010	Chen	D26/89
7,857,497	B2	12/2010	Koike et al.	
7,862,210	B2	1/2011	Zhang et al.	
7,866,847	B2	1/2011	Zheng	
7,874,700	B2	1/2011	Patrick	
7,959,329	B2	6/2011	Van De Ven	
7,972,036	B1	7/2011	Schach et al.	
7,979,197	B2	7/2011	Finn et al.	
8,157,422	B2	4/2012	Paik et al.	
8,164,237	B2	4/2012	Wen	
8,226,273	B2	7/2012	Lai	
8,235,097	B2	8/2012	Scordino et al.	
8,272,765	B2	9/2012	Ter-Hovhannisyan	
2009/0296387	A1	12/2009	Reisenauer et al.	
2010/0091487	A1	4/2010	Shin	
2010/0124058	A1	5/2010	Miller	
2010/0172143	A1	7/2010	Cunius	
2011/0110095	A1	5/2011	Li et al.	

**OTHER PUBLICATIONS**

From eurostylelighting.com, visited on Aug. 5, 2010—Murray Feiss Essentail Ceiling light; 2.) Sonneman Vienna Ceiling light; 3.) Forecast satin nickel ceiling light.\*

From eurostylelighting.com, visited on Aug. 5, 2010—Sonneman Vienna polished nickel 17" ceiling light.\*

From eurostylelighting.com, visited on Aug. 5, 2010—Forecast Presto Collection 10" wide ceiling light.\*

From eurostylelighting.com, visited on Aug. 5, 2010—Sonneman Trumpet 21" surface ceiling light and Sonneman Rialto 17" ceiling light.\*

American Electric Lighting, LEDR LED Roadway, Advertising Brochure, before Dec. 20, 2010, 12 pages.

Dialight Corporation, DuroSite, LED Low Bay Fixture, unknown publication date, 2 pages, Dialight Website.

Dialight Corporation, DuroSite\_highbay\_dlc, Press Release, Aug. 25, 2010, 1 page, Dialight Website.

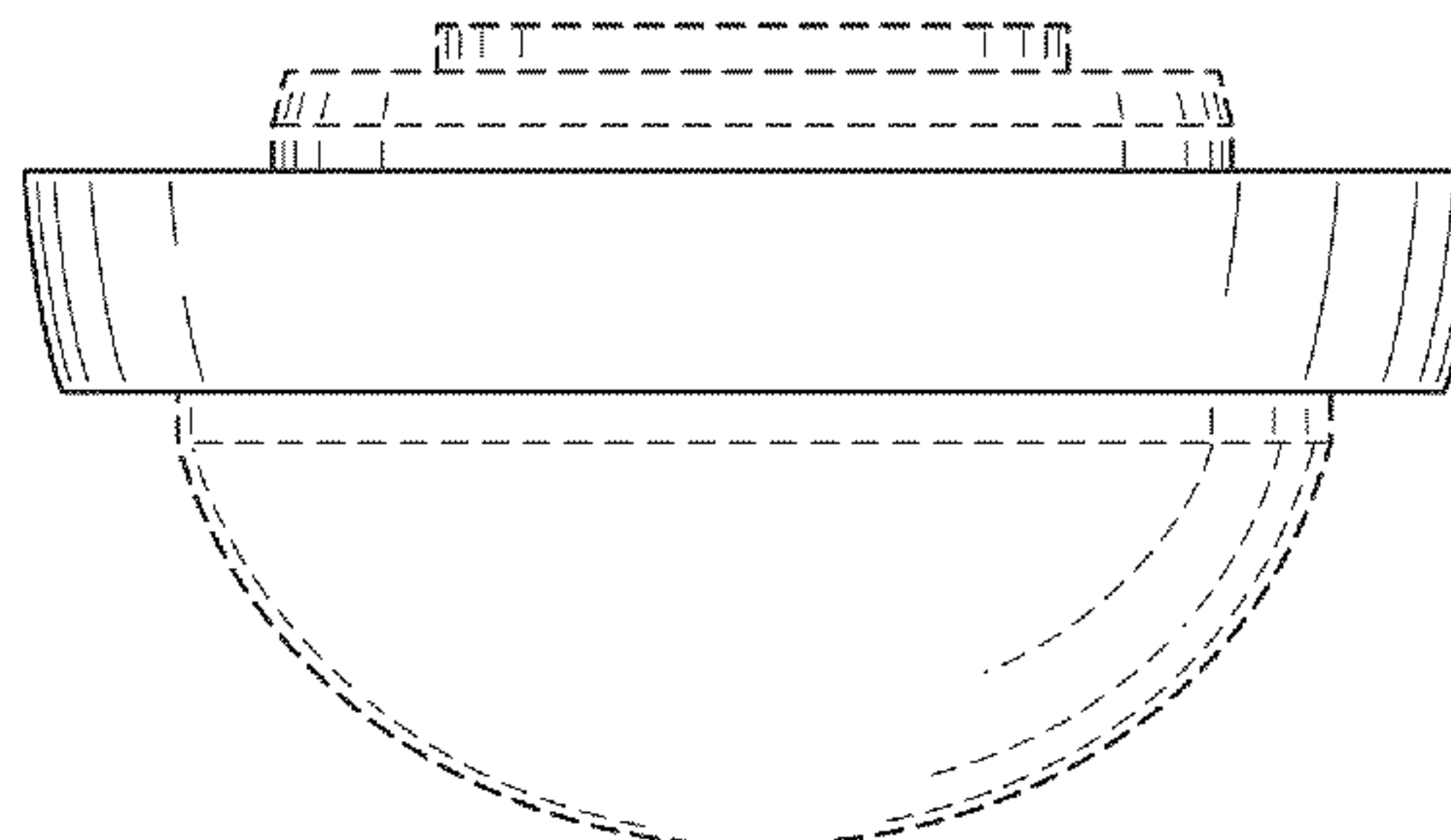
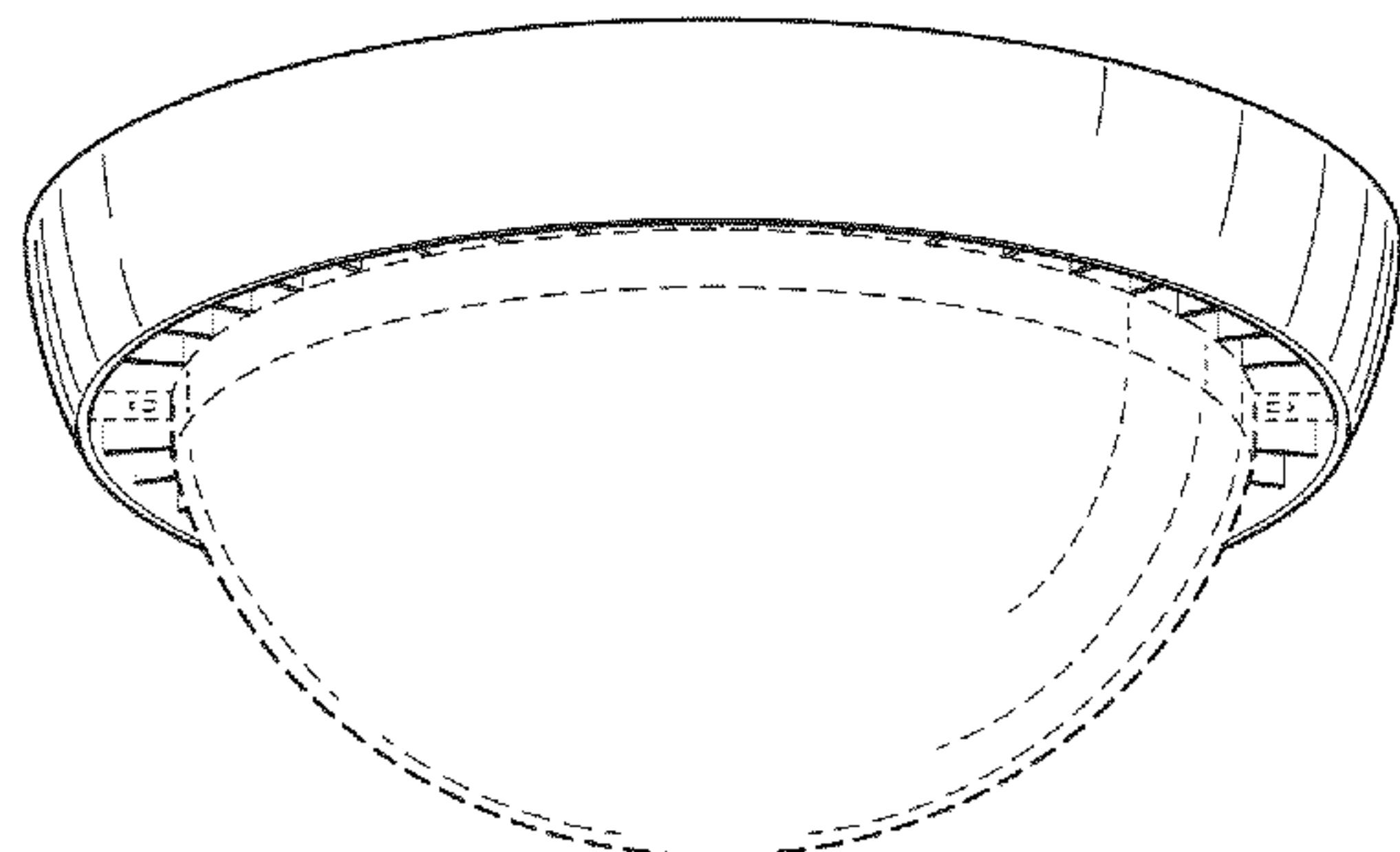
Dialight Corporation, DuroSite\_LED\_Lowboy, Press Release, Apr. 5, 2011, 1 page, Dialight Website.

Dialight, DuroSite LED High Bay, Advertising Brochure, before Dec. 20, 2010, 8 pages.

Electromatic Products, High Light Low Energy LED Lighting, Advertising Brochure, before Dec. 20, 2010, 2 pages.

Philips Corporation, Canlyte product brochure, unknown date, 16 pages—reference p. 7, Canlyte a Philips Group Brand, Printed in Canada.

\* cited by examiner



*Primary Examiner* — Clare E Hefflin

(74) *Attorney, Agent, or Firm* — Marshall, Gerstein & Borun  
LLP; Michael P. Furmanek

(57)

**CLAIM**

The ornamental design for a lighting fixture, as shown and described.

**DESCRIPTION**

FIG. 1 is a perspective view showing a new design for a lighting fixture angled rearward approximately 15 degrees from vertical;

FIG. 2 is a front view of the lighting fixture of FIG. 1;

FIG. 3 is a bottom view of the lighting fixture of FIG. 1;

FIG. 4 is a perspective view of the lighting fixture of FIG. 1 angled rearward approximately 30 degrees from vertical;

FIG. 5 is a perspective view of the lighting fixture of FIG. 1 angled rearward approximately 45 degrees from vertical;

FIG. 6 is a perspective view showing a second embodiment of a new design for a lighting fixture angled rearward approximately 15 degrees from vertical;

FIG. 7 is front view of the lighting fixture of FIG. 6;

FIG. 8 is a bottom view of the lighting fixture of FIG. 6;

FIG. 9 is a perspective view of the lighting fixture of FIG. 6 angled rearward approximately 30 degrees from vertical;

FIG. 10 is a perspective view of the lighting fixture of FIG. 6 angled rearward approximately 45 degrees from vertical;

FIG. 11 is a perspective view showing a third embodiment of a new design for a lighting fixture angled rearward approximately 15 degrees from vertical;

FIG. 12 is front view of the lighting fixture of FIG. 11;

FIG. 13 is a bottom view of the lighting fixture of FIG. 11;

FIG. 14 is a perspective view of the lighting fixture of FIG. 11 angled rearward approximately 30 degrees from vertical;

FIG. 15 is a perspective view of the lighting fixture of FIG. 11 angled rearward approximately 45 degrees from vertical;

FIG. 16 is a perspective view showing a fourth embodiment of a new design for a lighting fixture angled rearward approximately 15 degrees from vertical;

FIG. 17 is front view of the lighting fixture of FIG. 16;

FIG. 18 is a bottom view of the lighting fixture of FIG. 16;

FIG. 19 is a perspective view of the lighting fixture of FIG. 16 angled rearward approximately 30 degrees from vertical;

FIG. 20 is a perspective view of the lighting fixture of FIG. 16 angled rearward approximately 45 degrees from vertical;

FIG. 21 is a perspective view showing a fifth embodiment of a new design for a lighting fixture angled rearward approximately 15 degrees from vertical;

FIG. 22 is front view of the lighting fixture of FIG. 21;

FIG. 23 is a bottom view of the lighting fixture of FIG. 21;

FIG. 24 is a perspective view of the lighting fixture of FIG. 21 angled rearward approximately 30 degrees from vertical;

FIG. 25 is a perspective view of the lighting fixture of FIG. 21 angled rearward approximately 45 degrees from vertical;

FIG. 26 is a perspective view showing a sixth embodiment of a new design for a lighting fixture angled rearward approximately 15 degrees from vertical;

FIG. 27 is front view of the lighting fixture of FIG. 26;

FIG. 28 is a bottom view of the lighting fixture of FIG. 26;

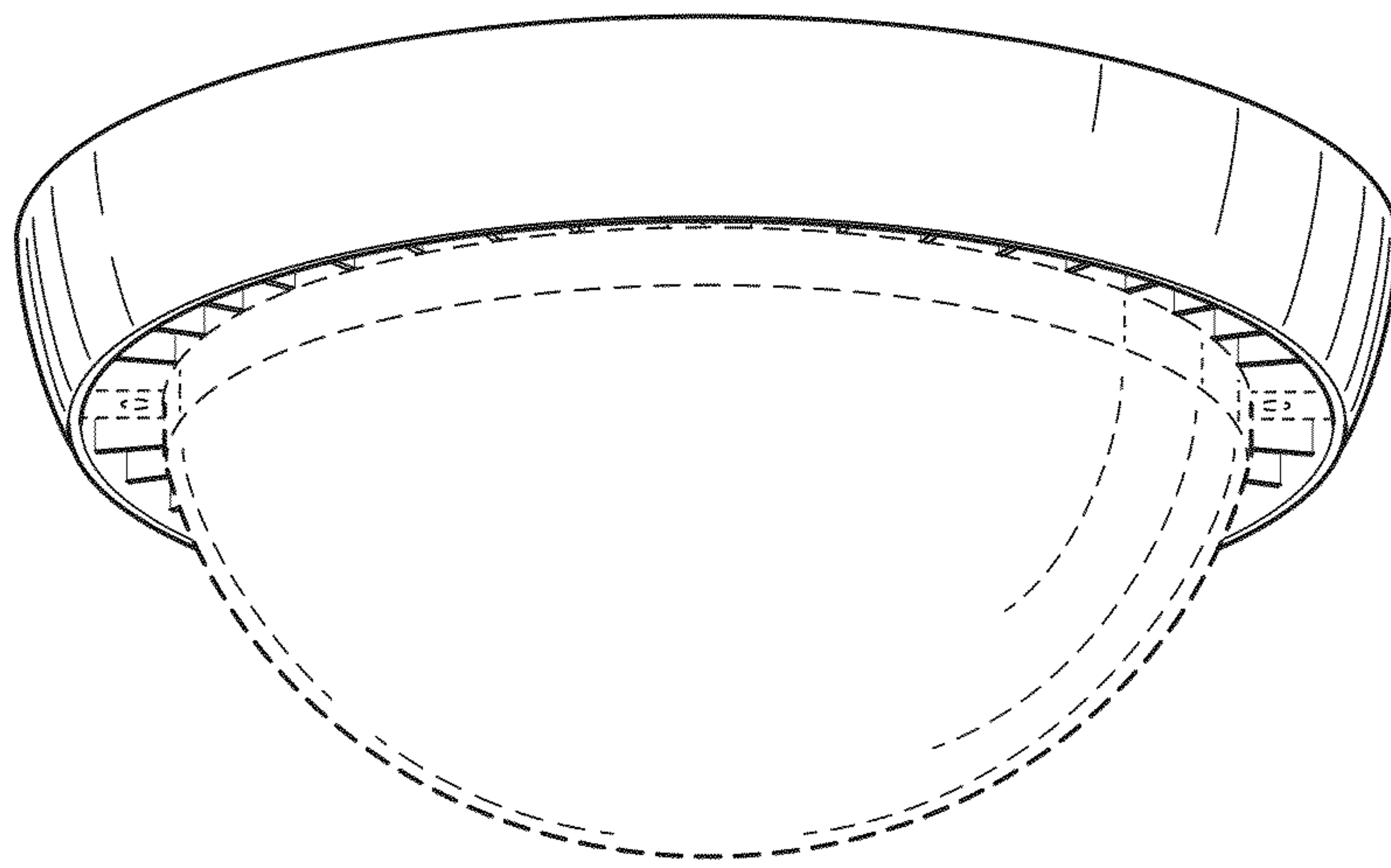
FIG. 29 is a perspective view of the lighting fixture of FIG. 26 angled rearward approximately 30 degrees from vertical; and,

FIG. 30 is a perspective view of the lighting fixture of FIG. 26 angled rearward approximately 45 degrees from vertical.

The broken lines showing portions of the lighting fixture are included for the purpose of illustrating environment and form no part of the claimed design.

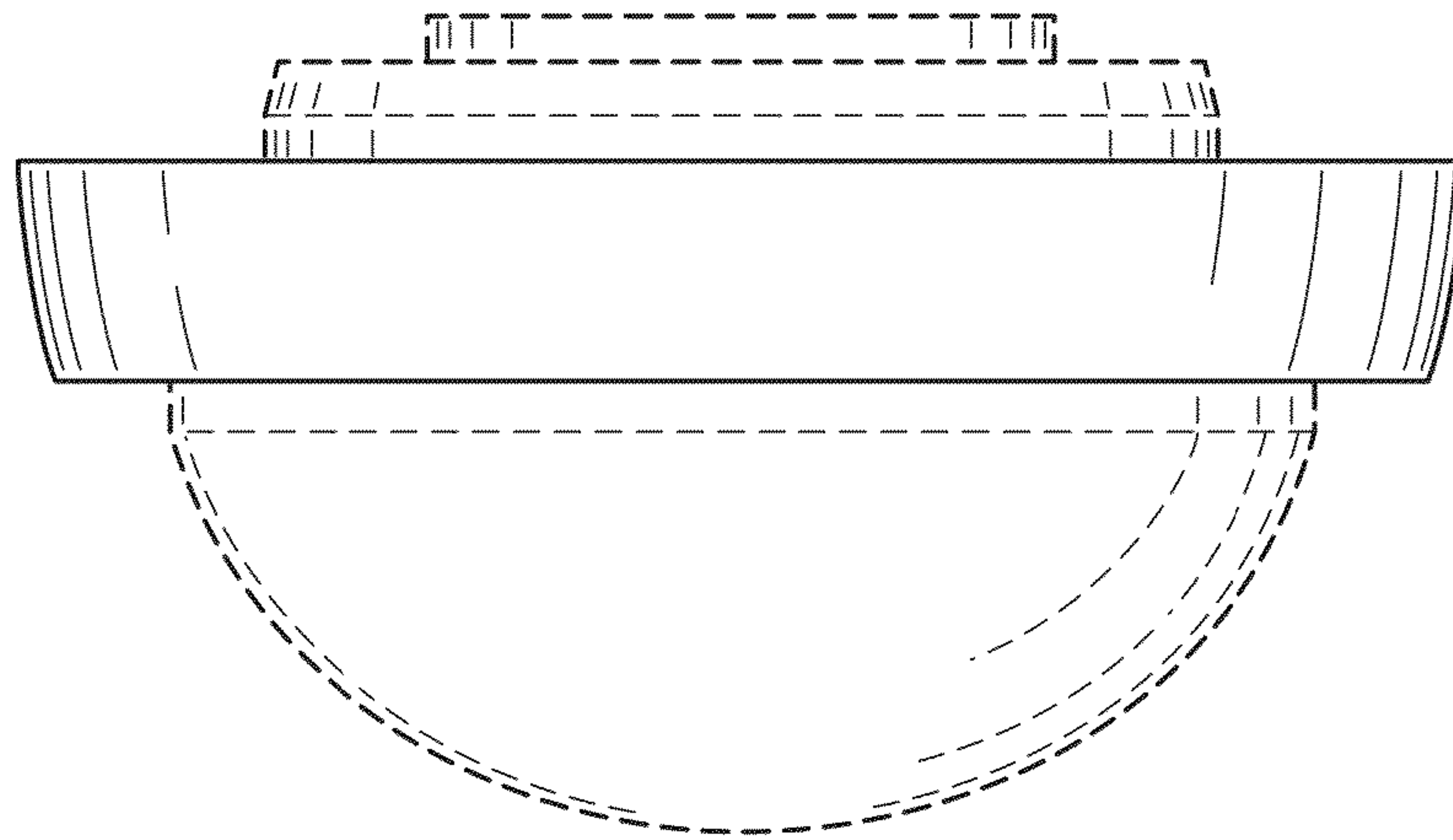
**1 Claim, 18 Drawing Sheets**

**FIG. 1**

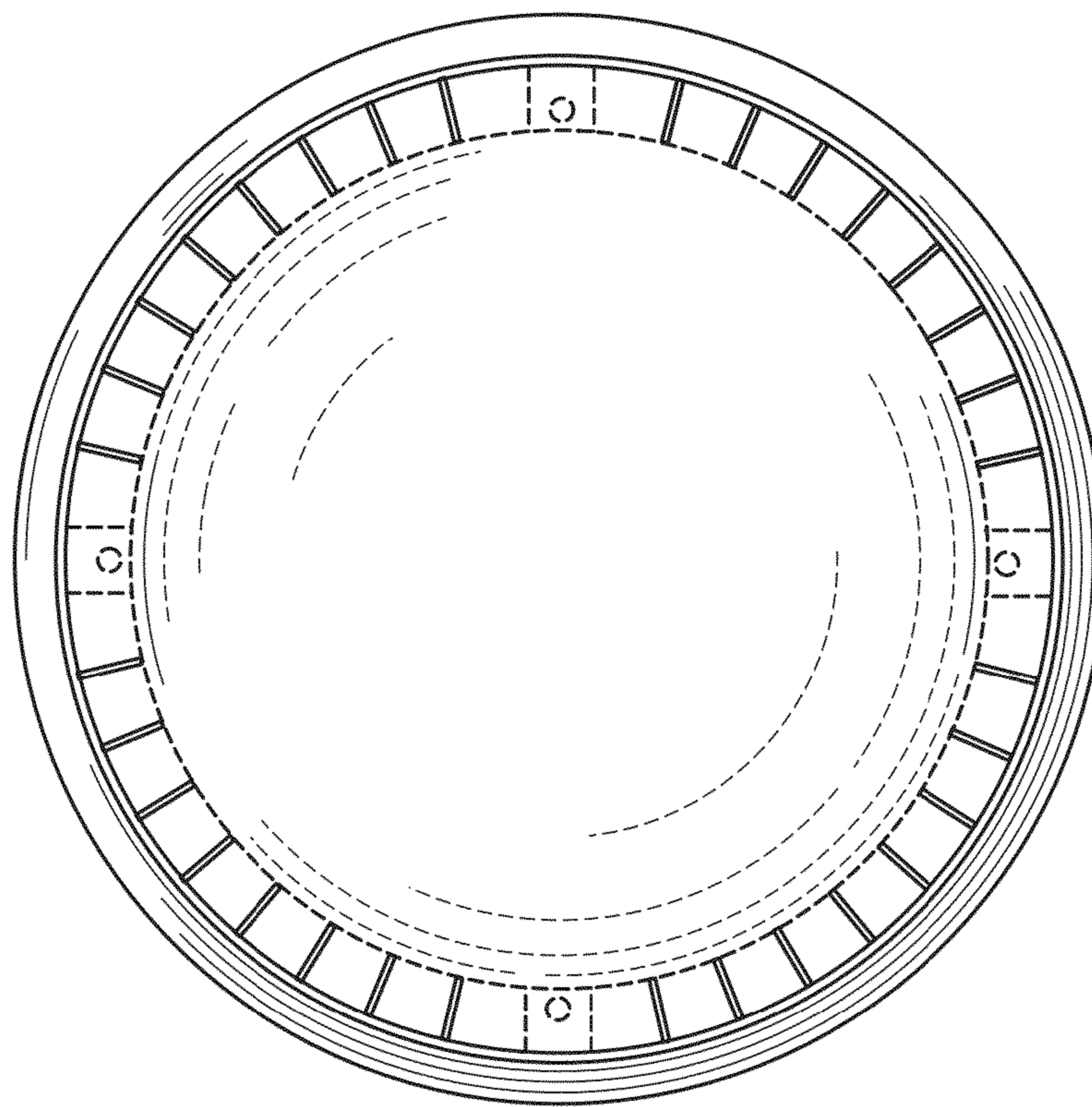


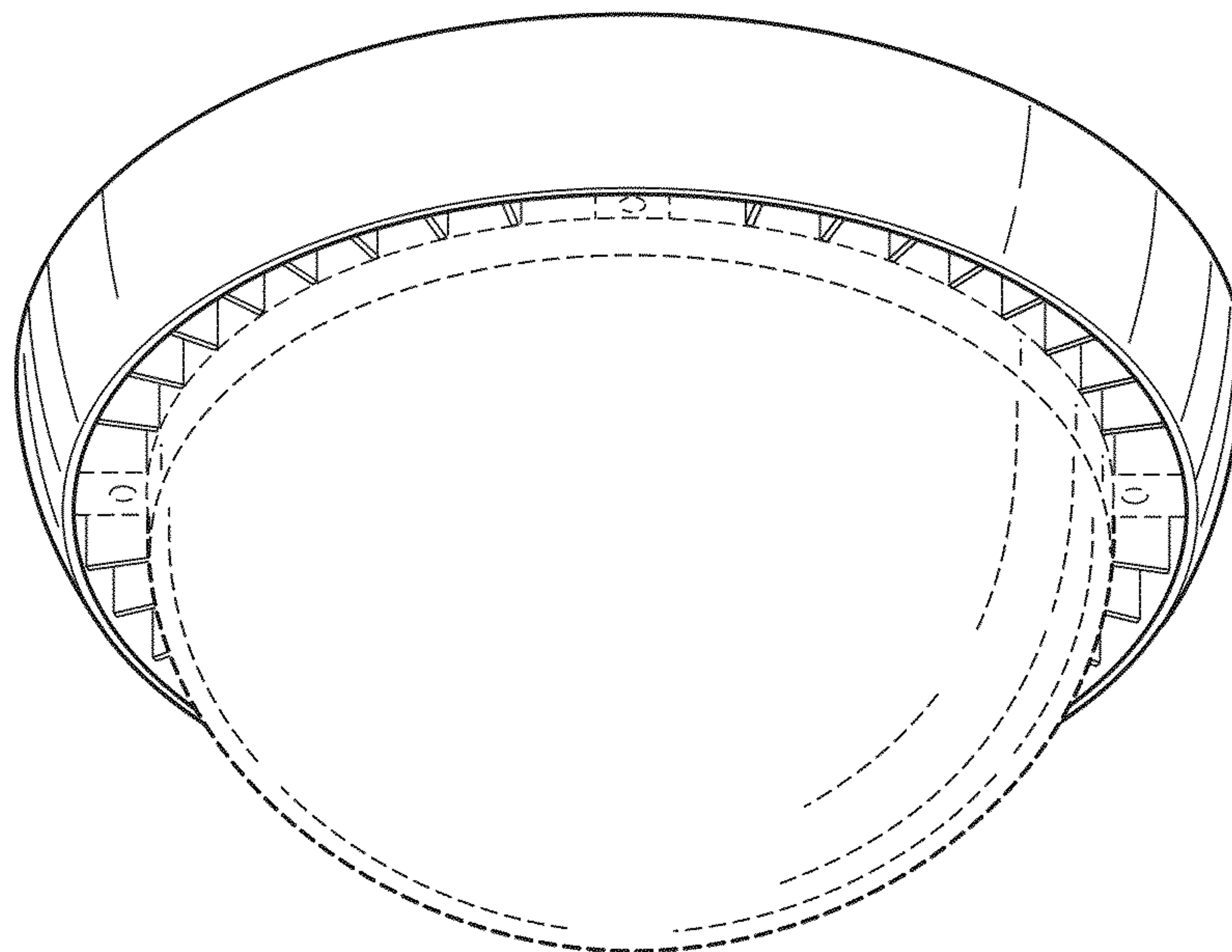


**FIG. 2**

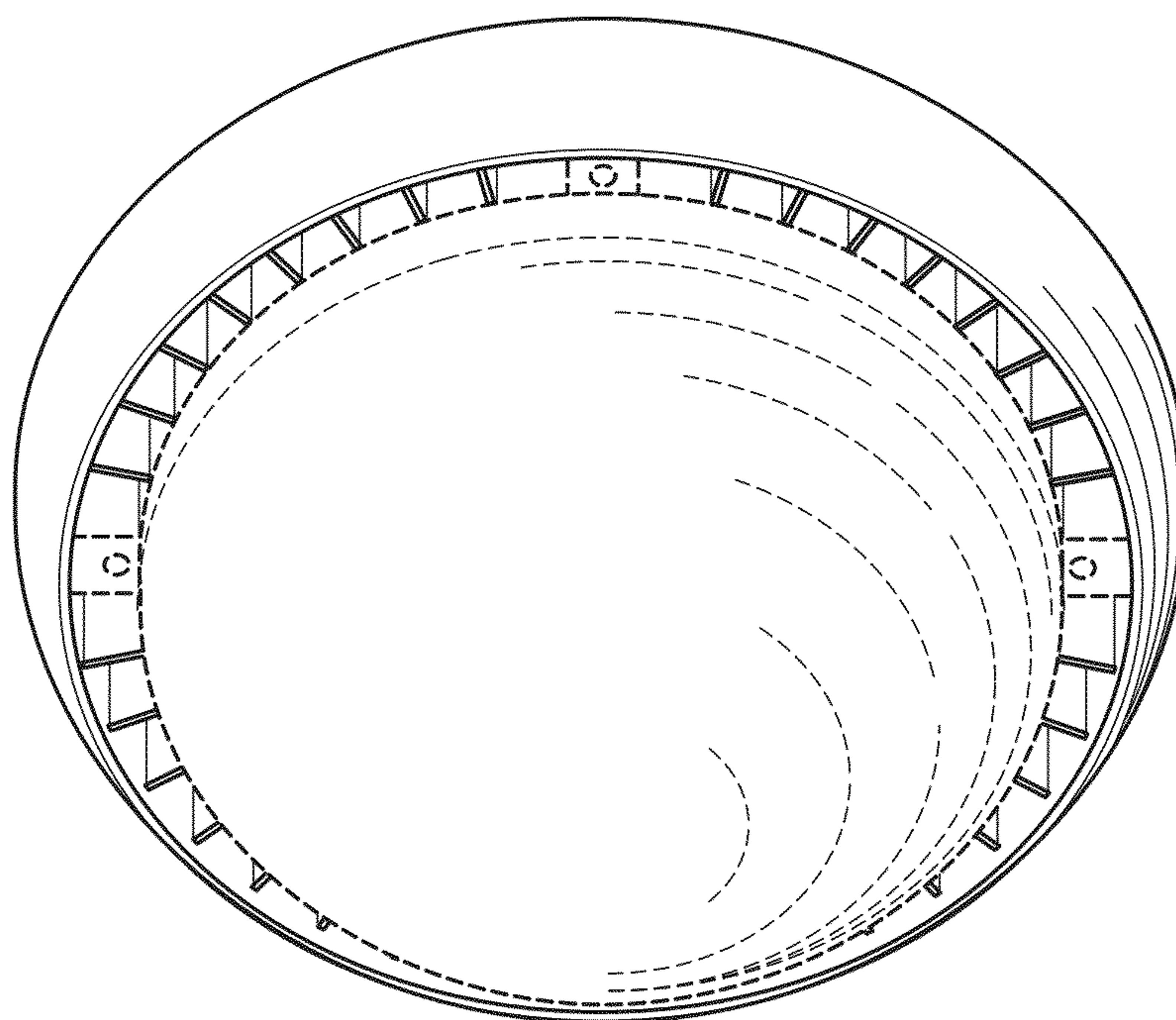


**FIG. 3**



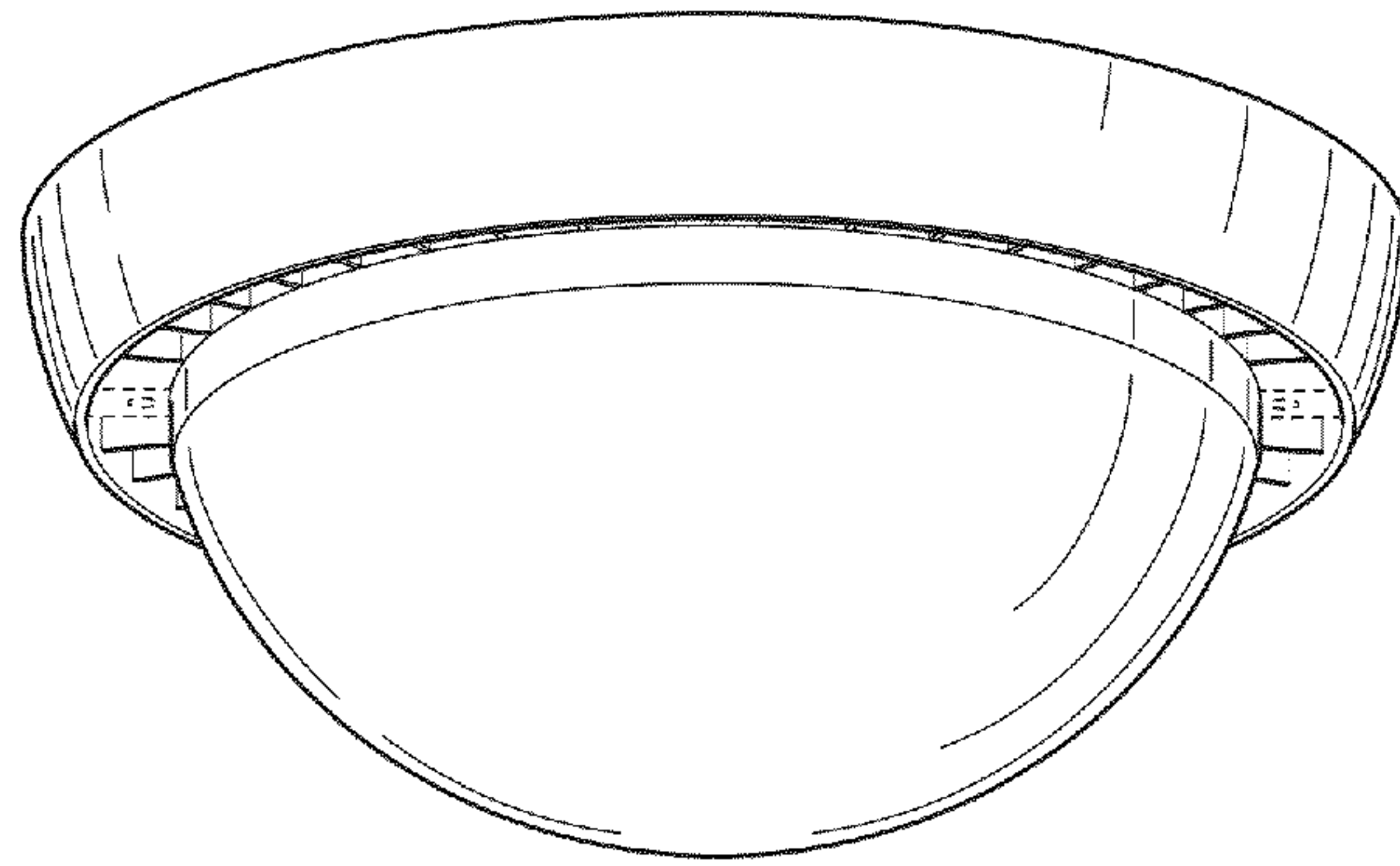


**FIG. 4**

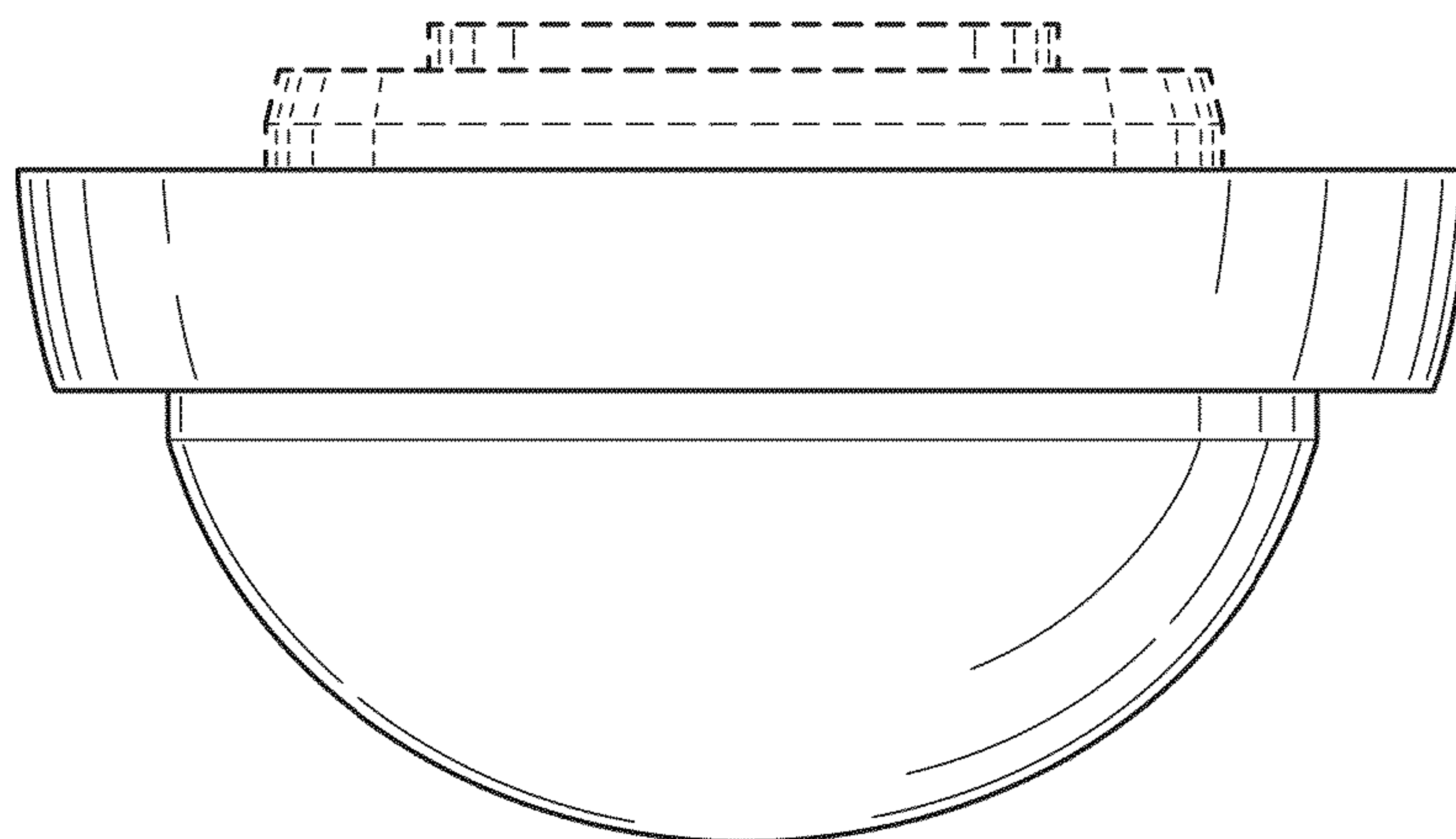


**FIG. 5**

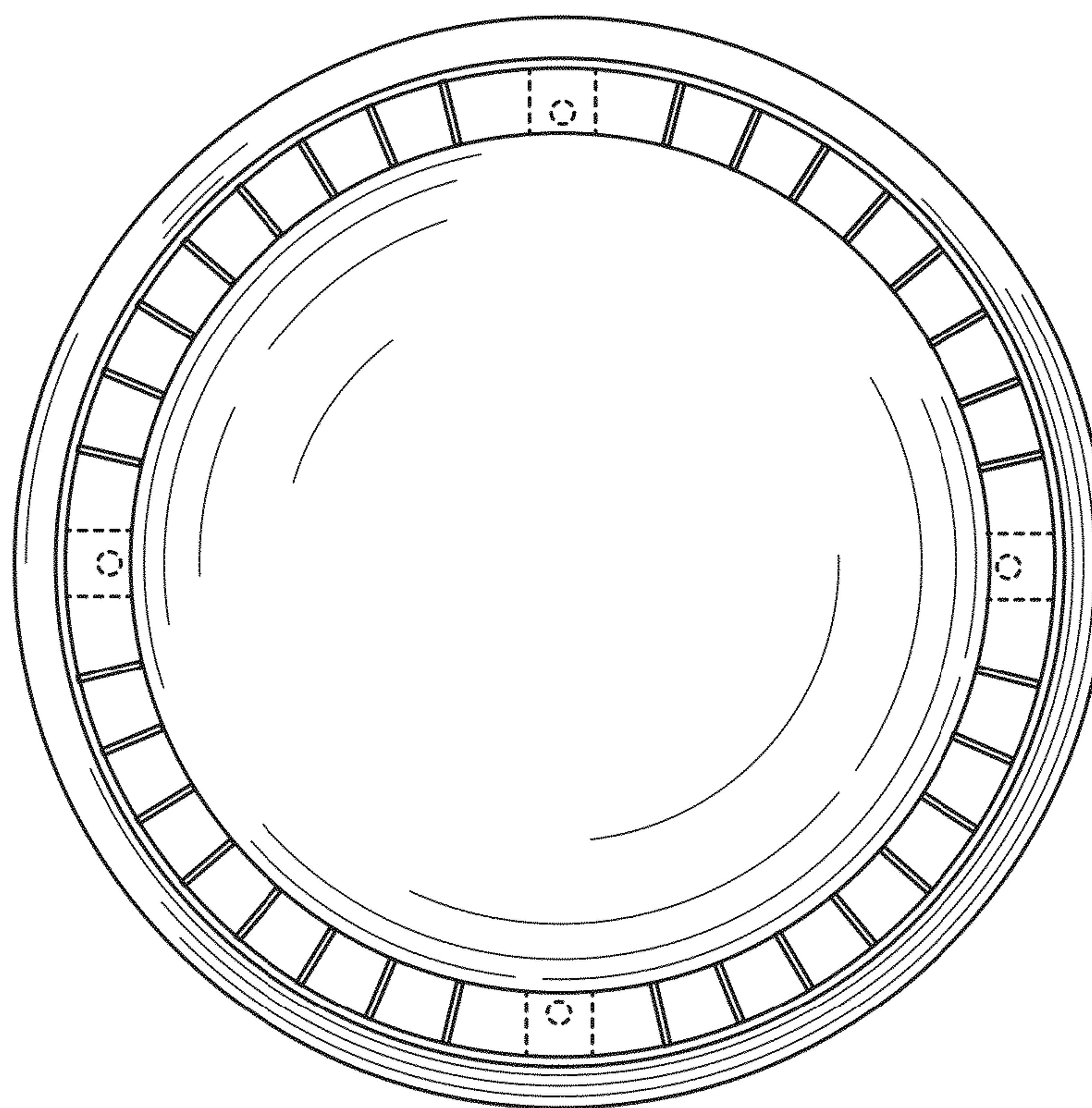
**FIG. 6**



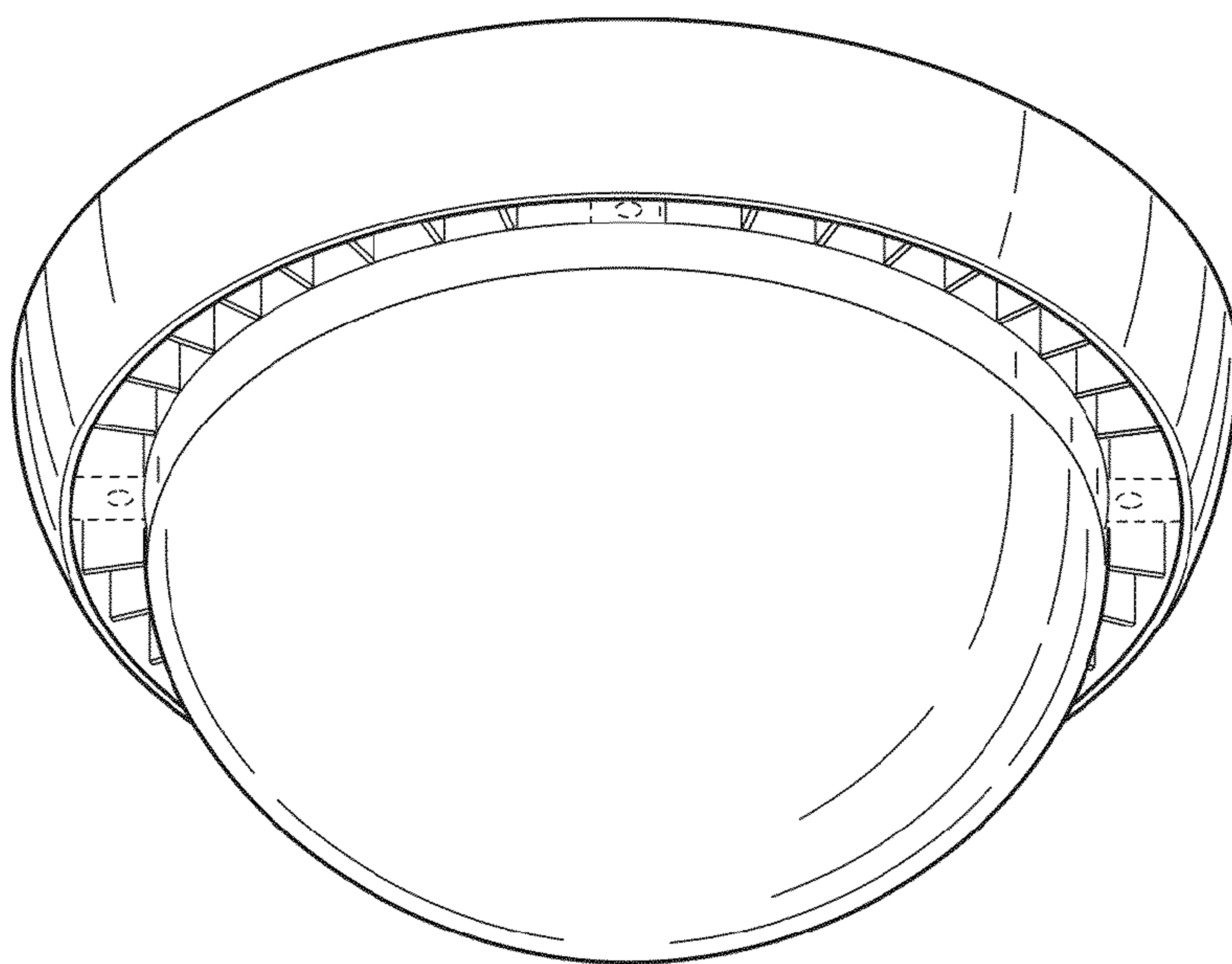
**FIG. 7**



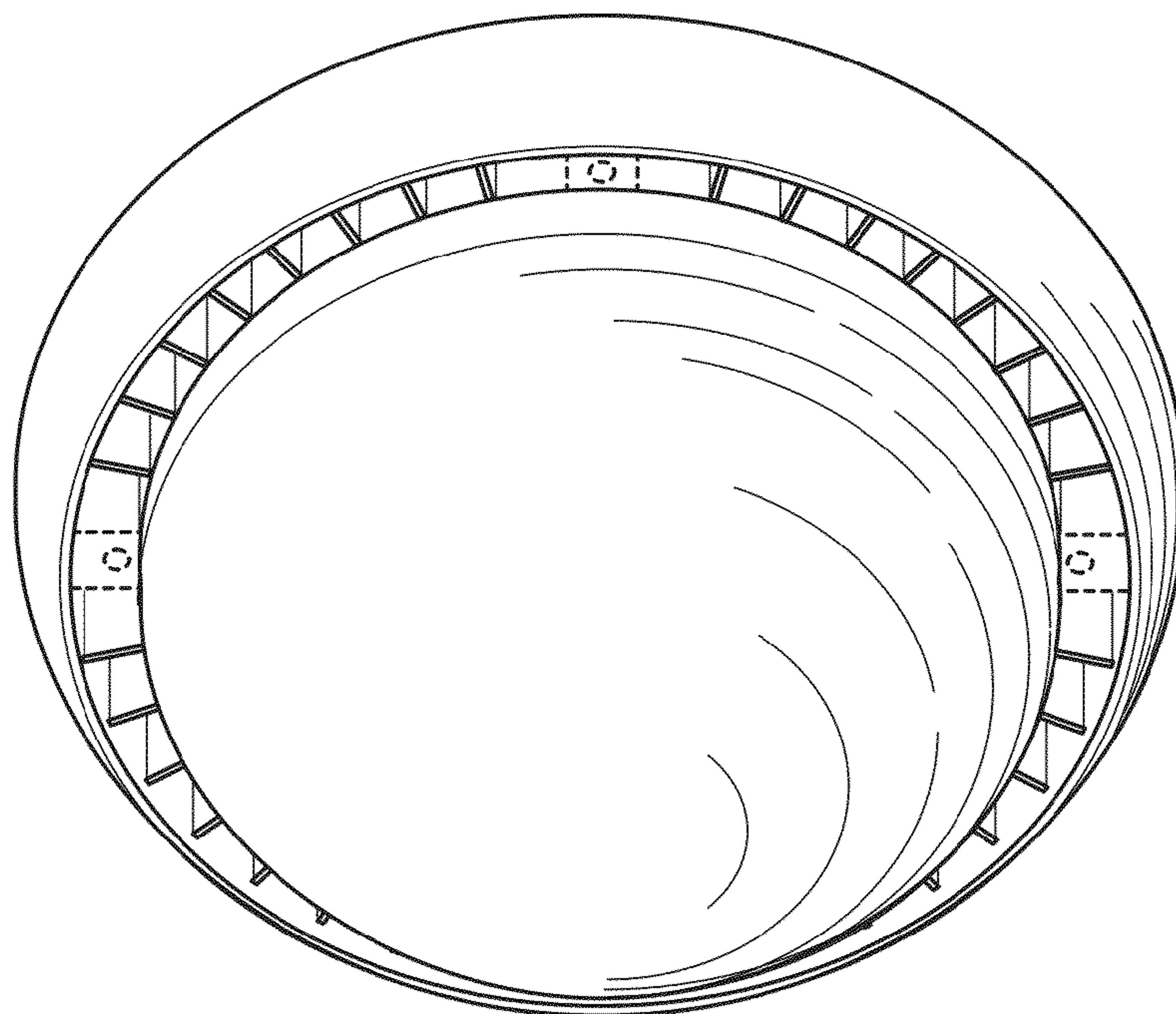
**FIG. 8**







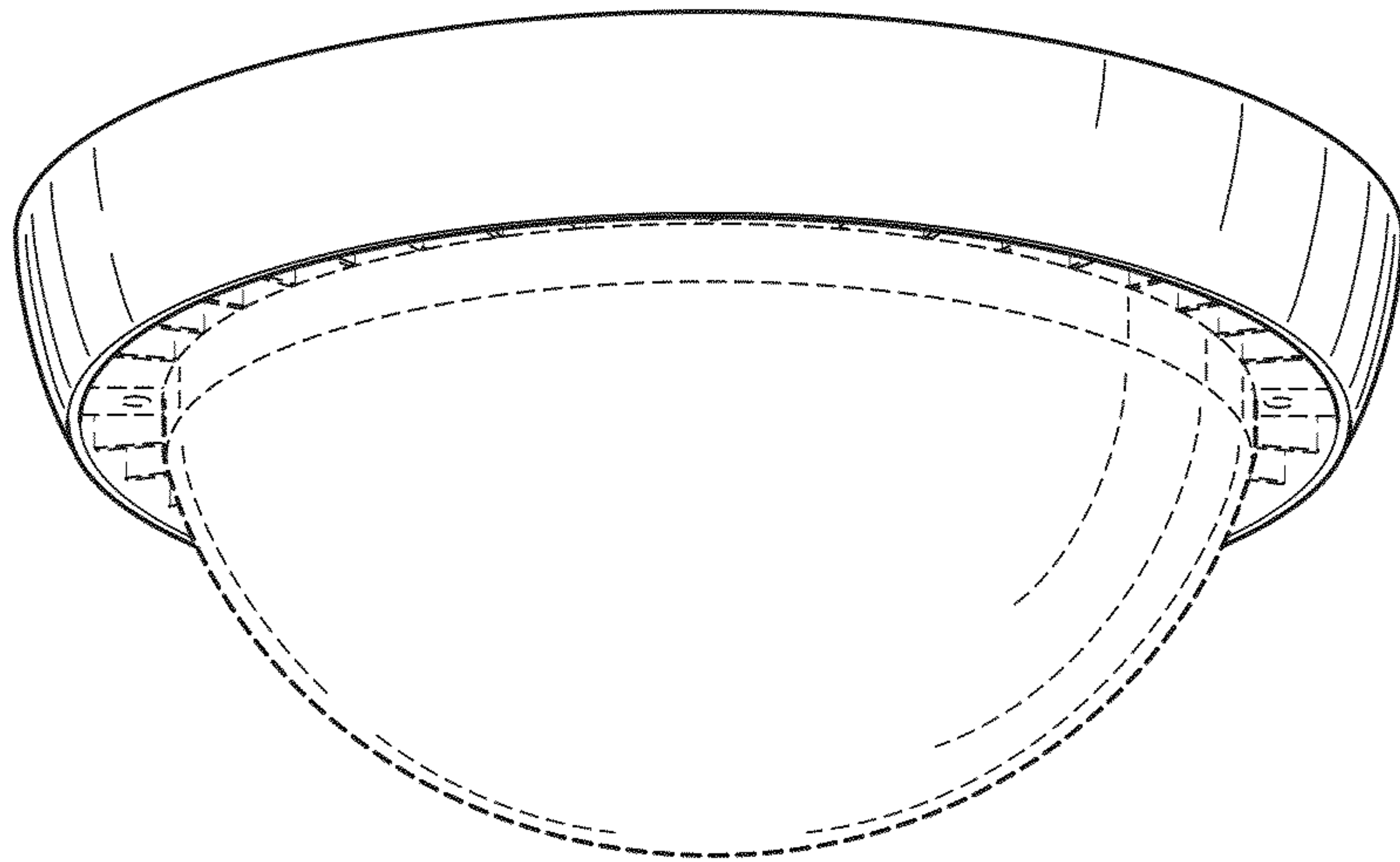
**FIG. 9**



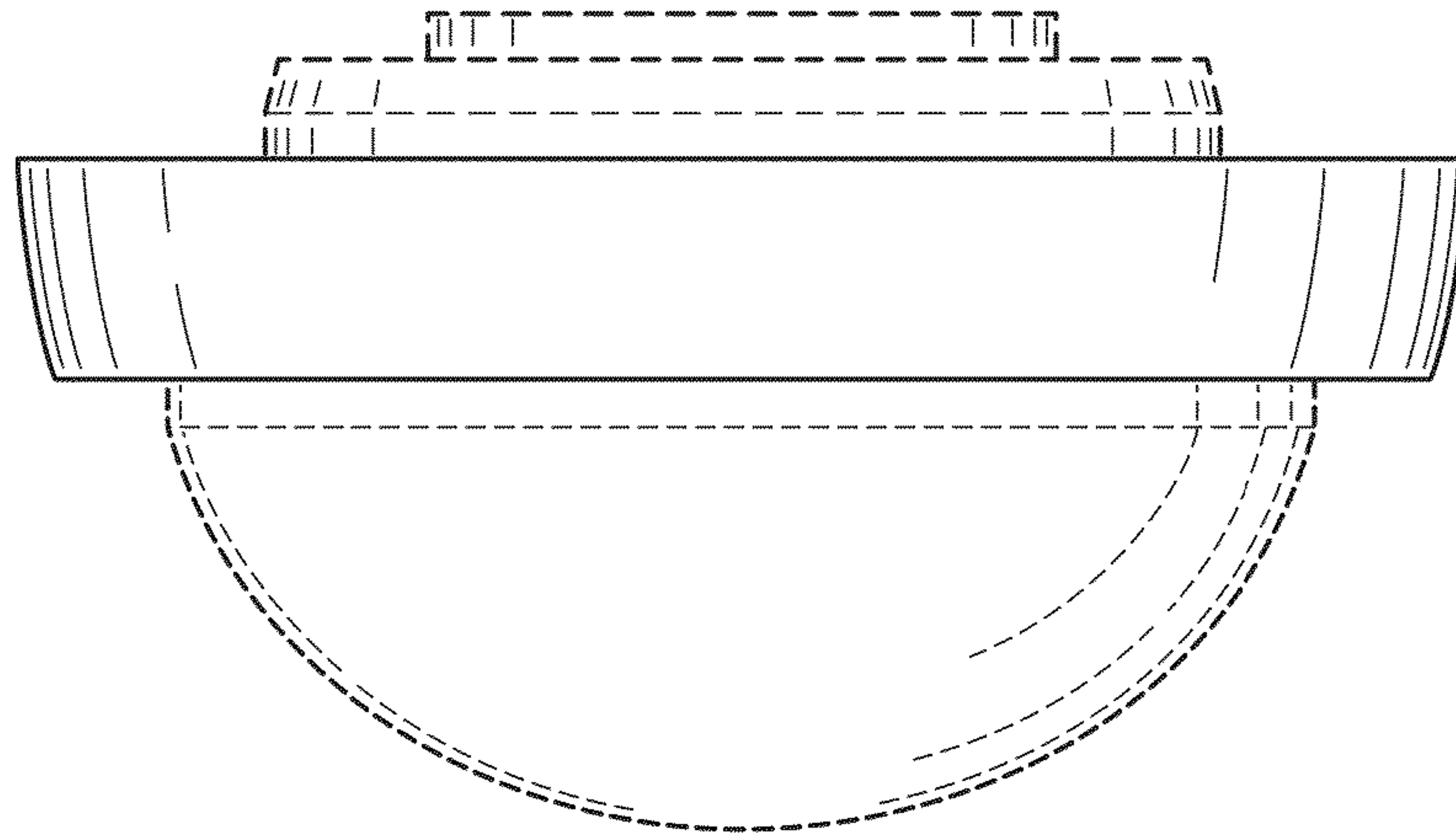
**FIG. 10**



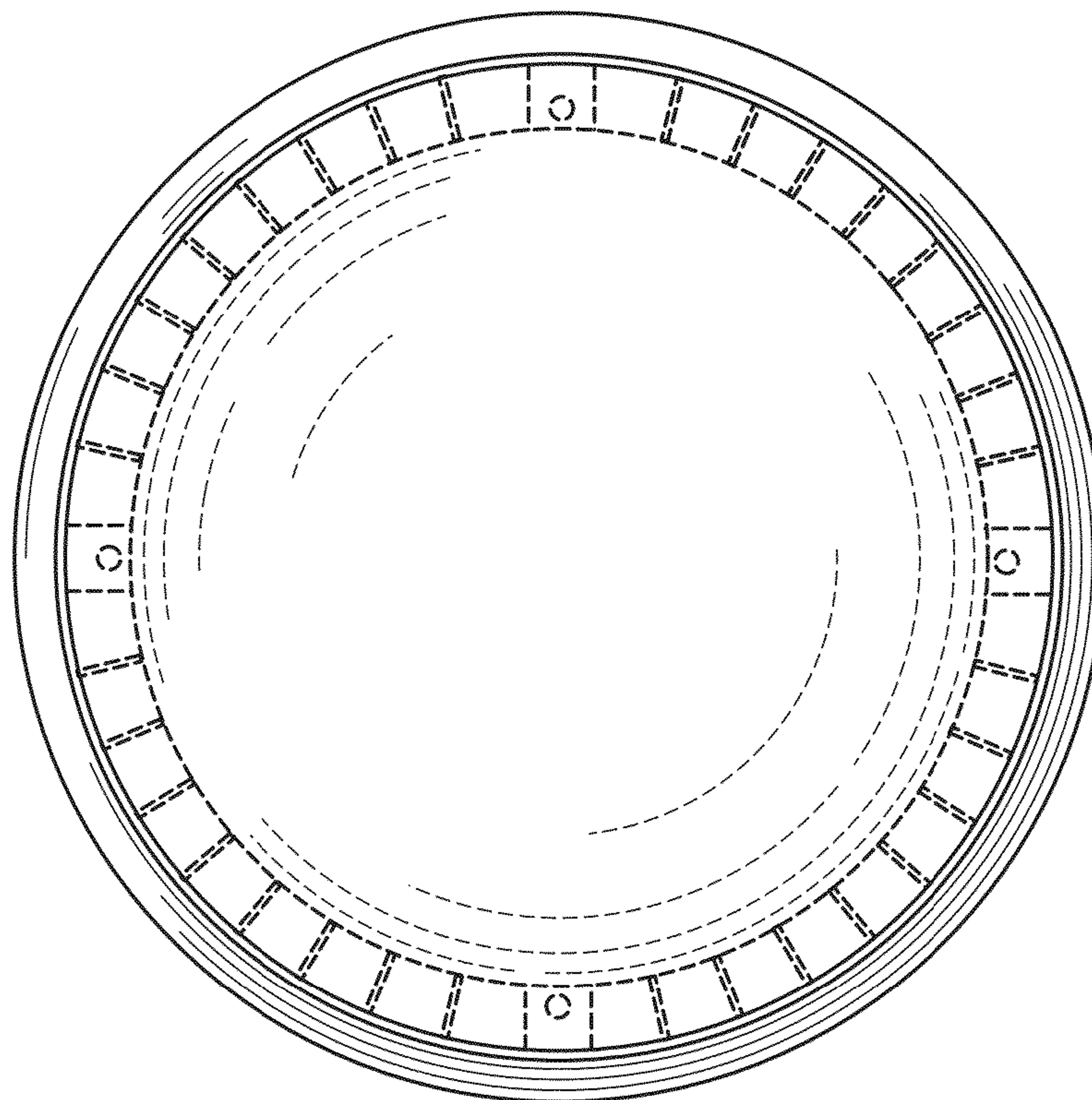
**FIG. 11**

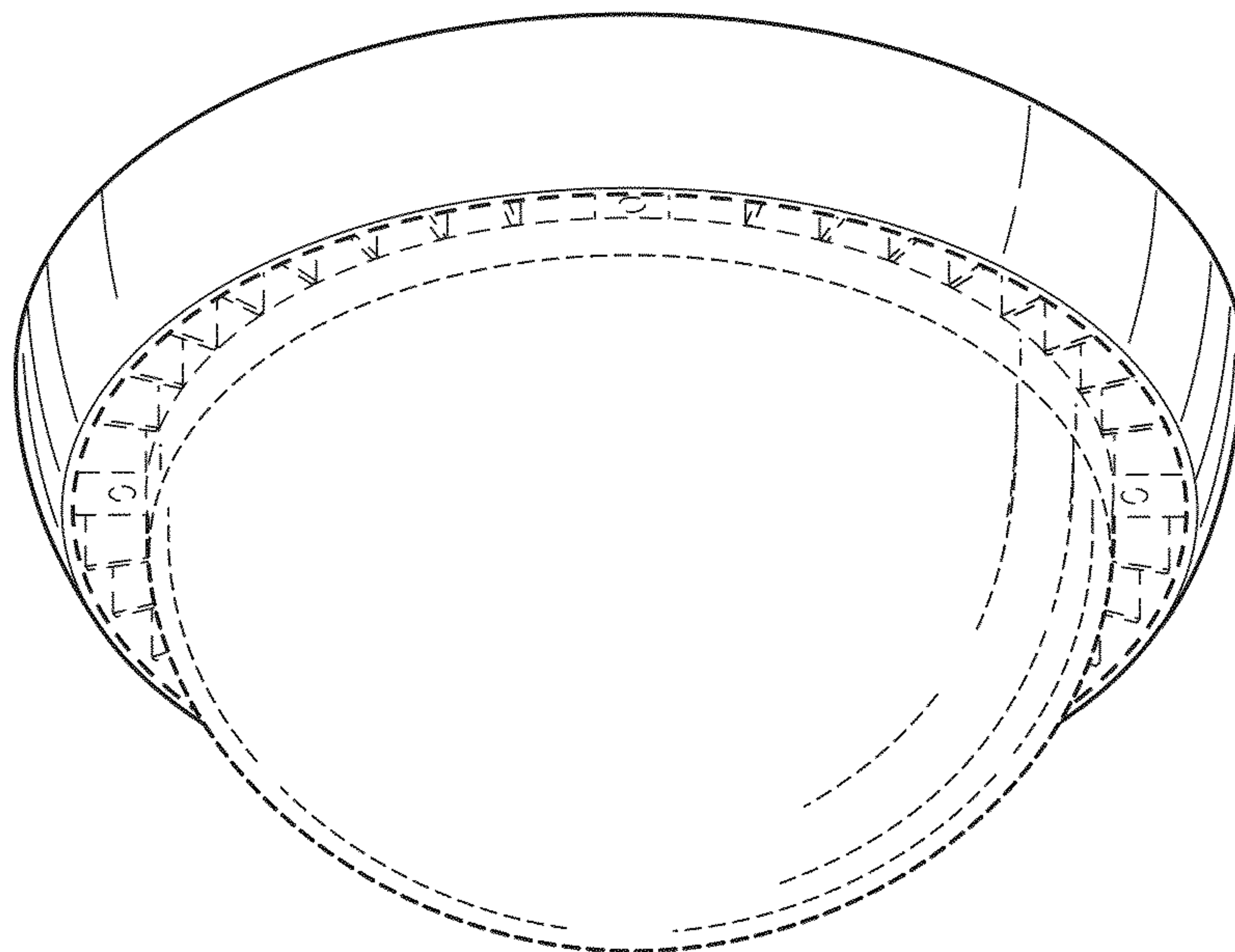


**FIG. 12**

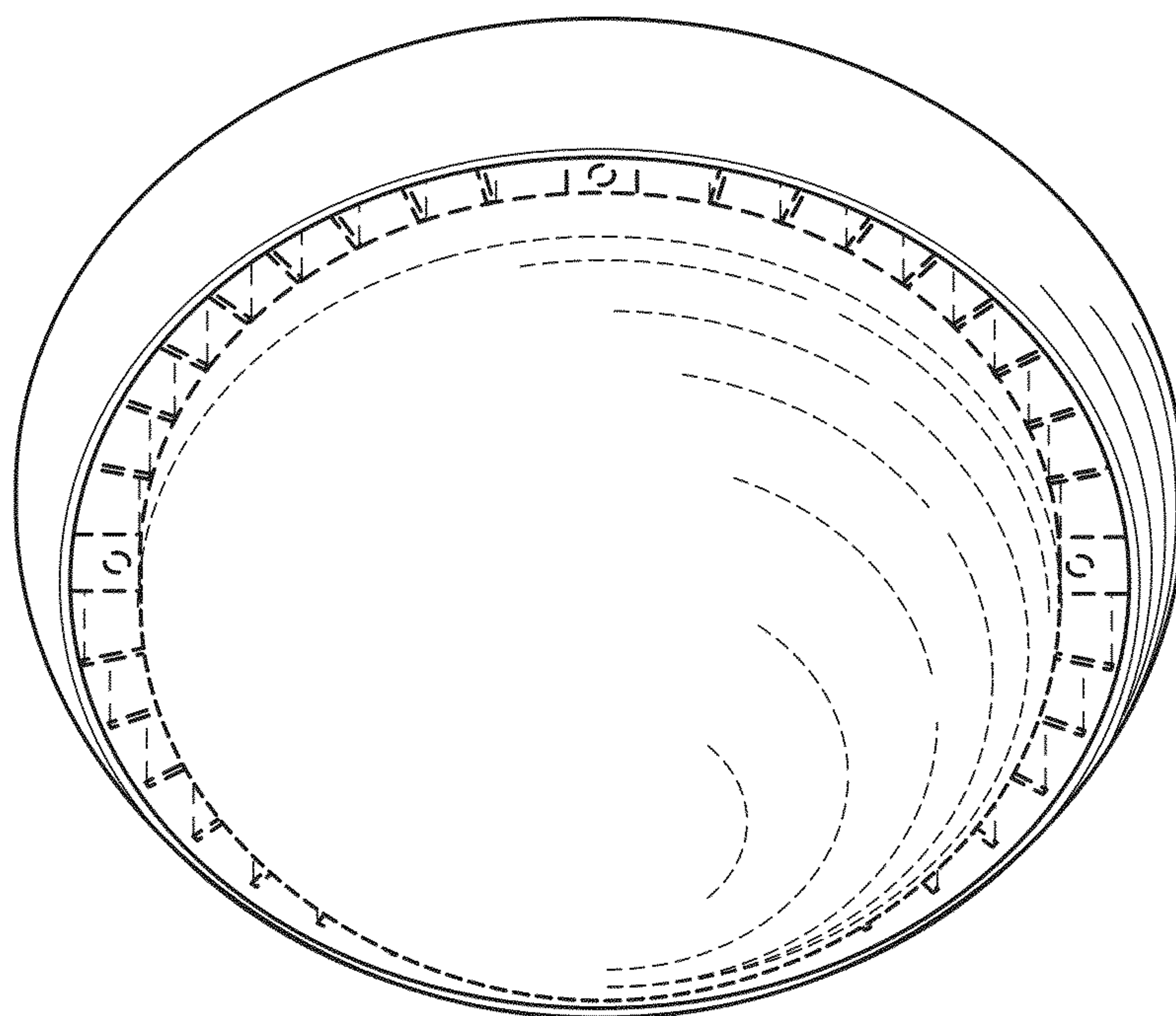


**FIG. 13**





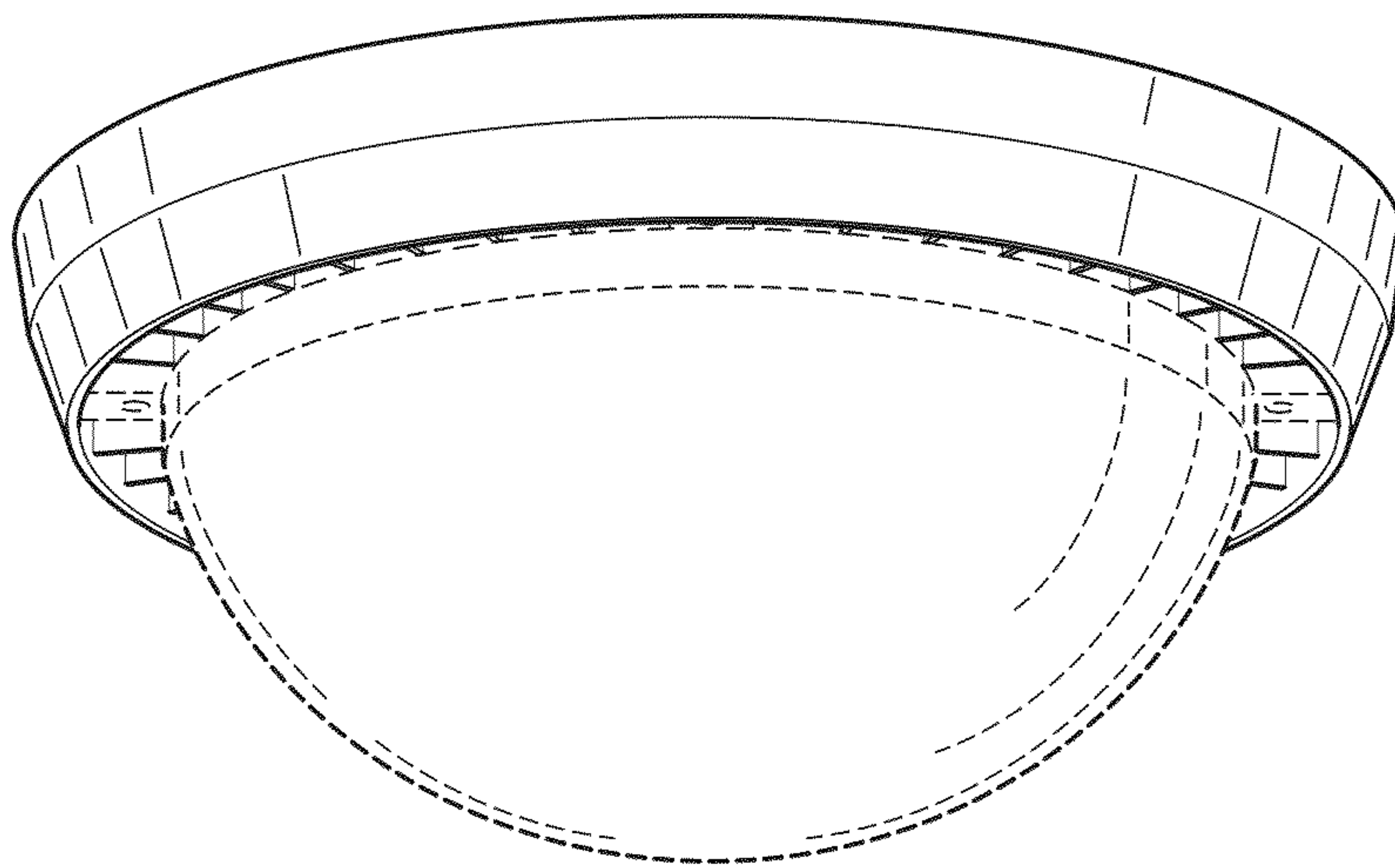
**FIG. 14**



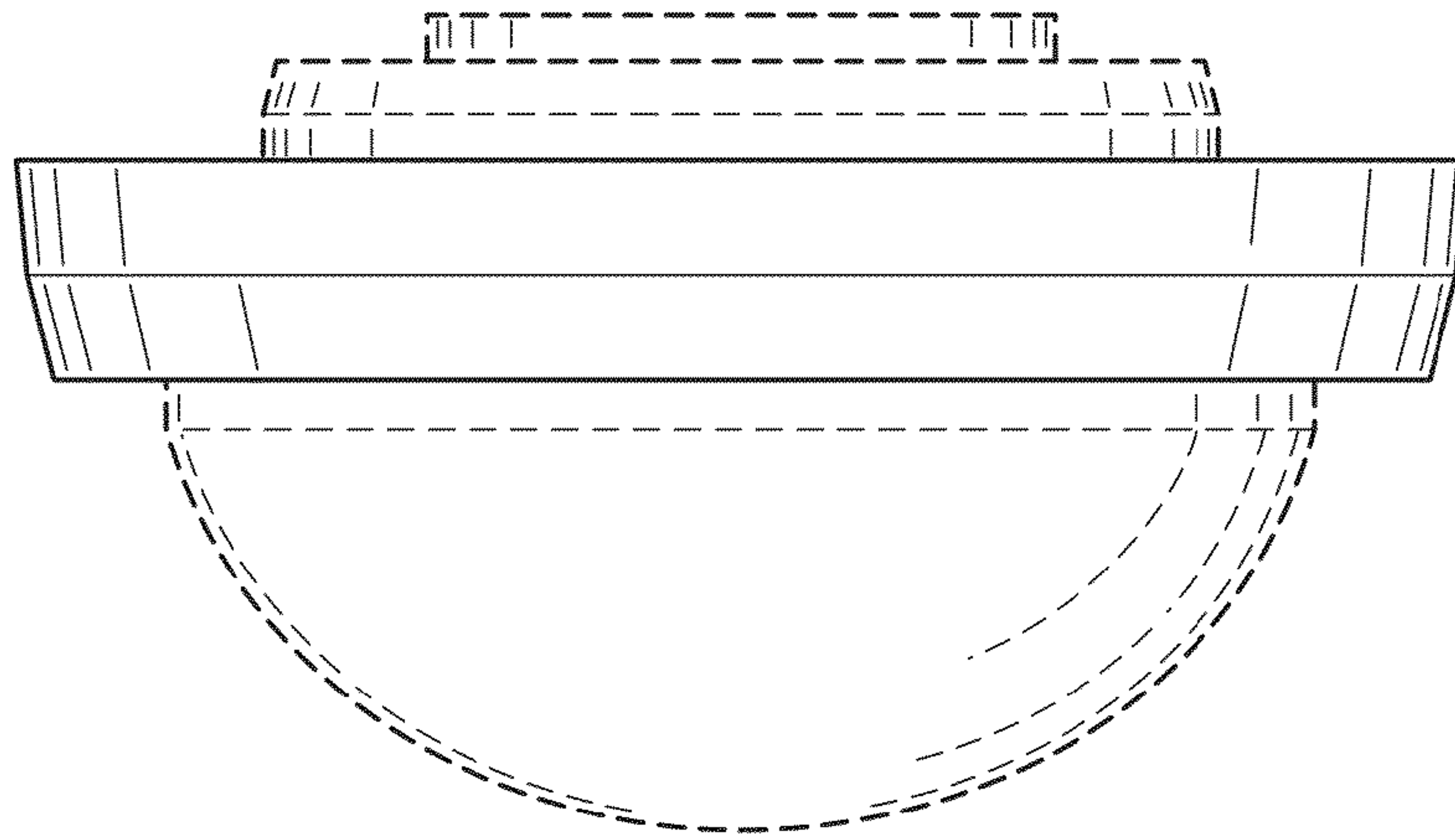
**FIG. 15**



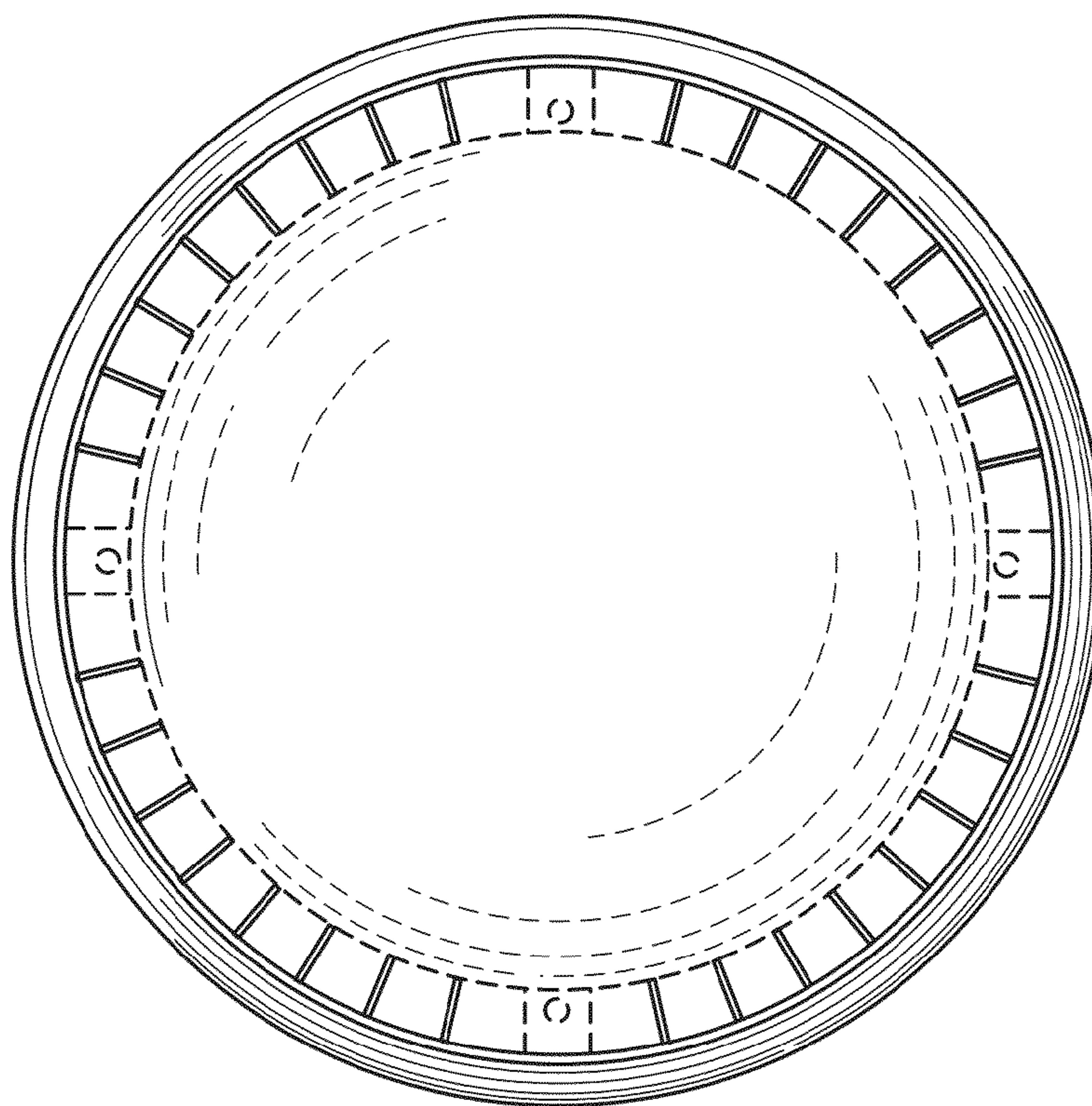
**FIG. 16**

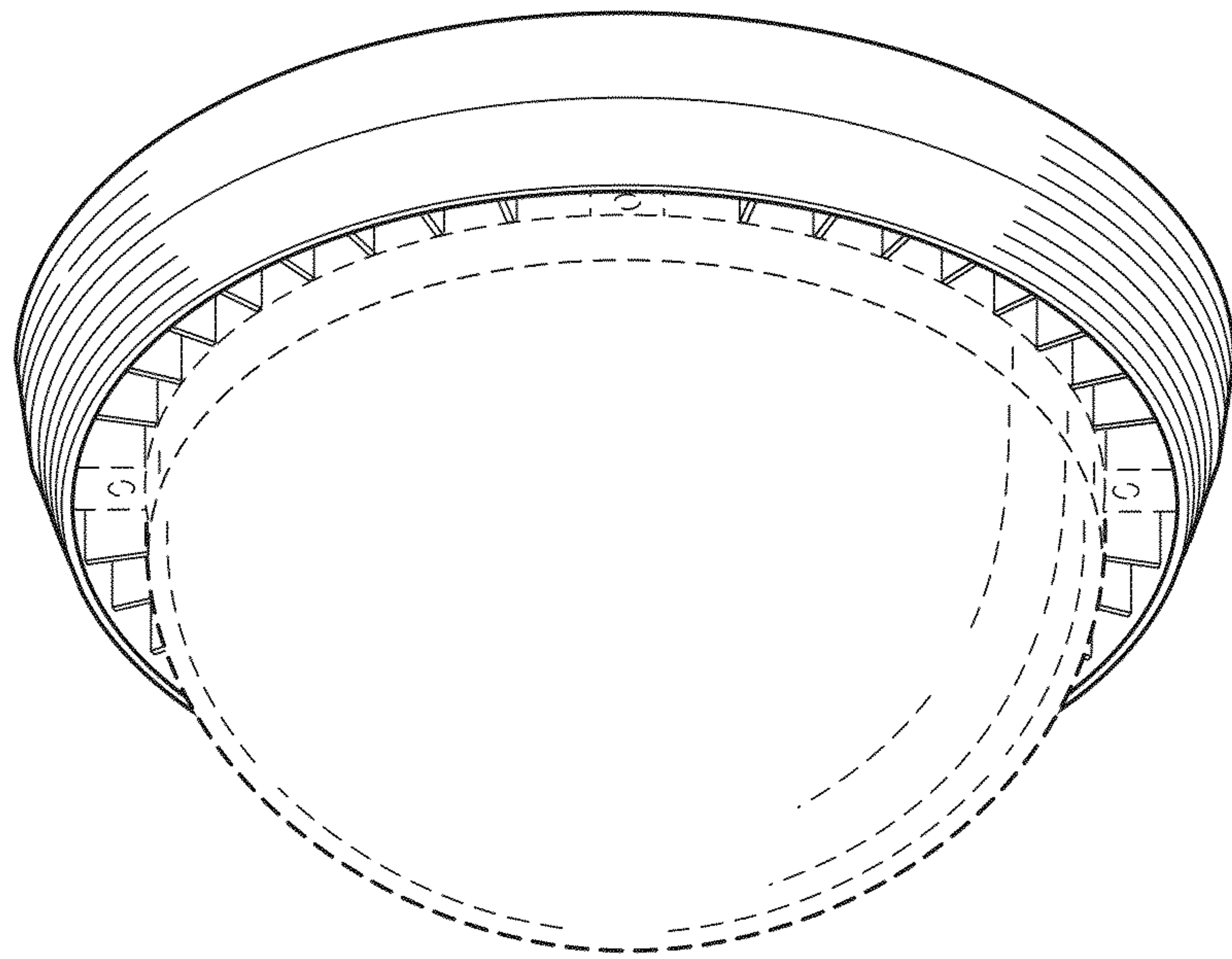


**FIG. 17**

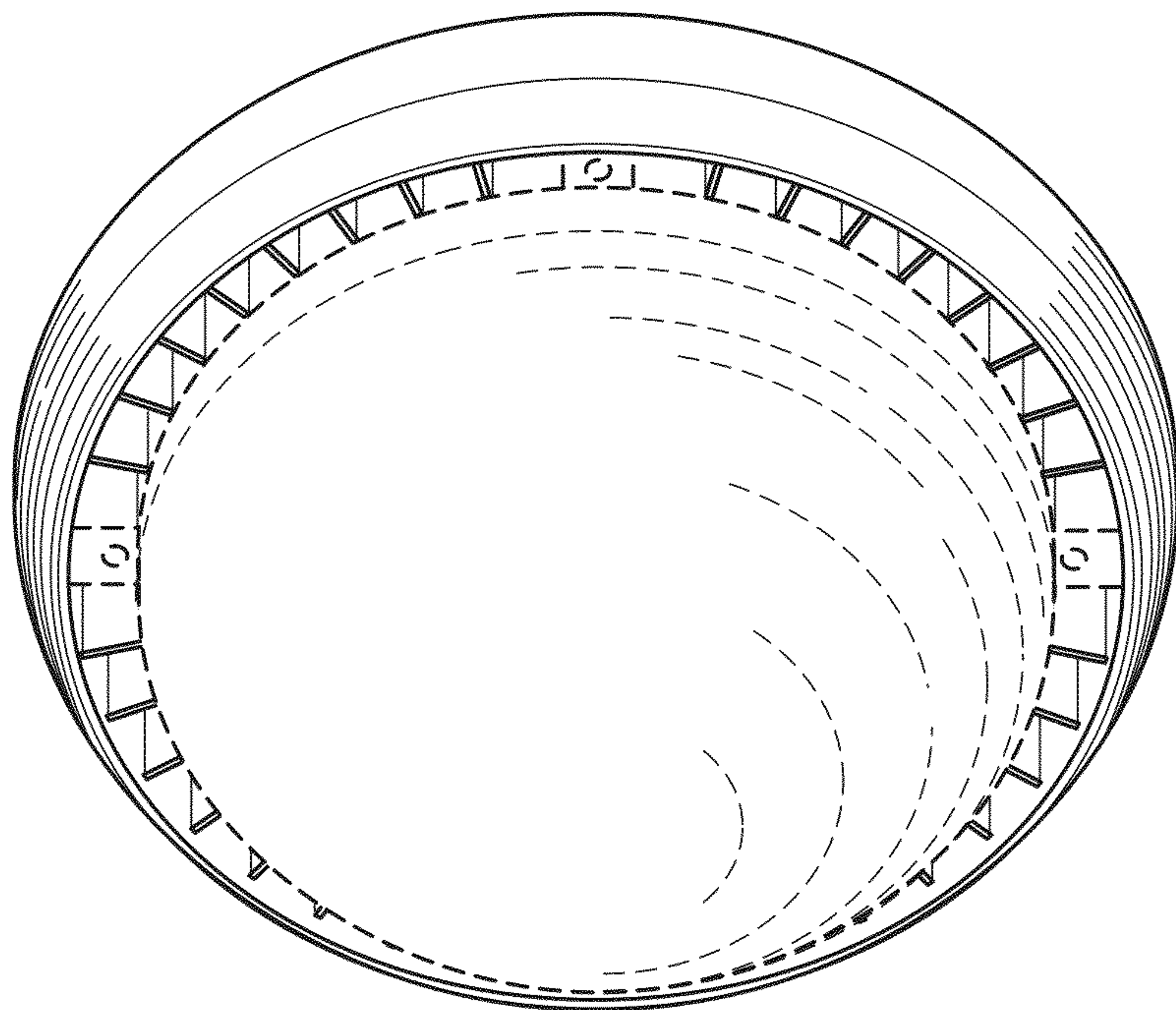


**FIG. 18**





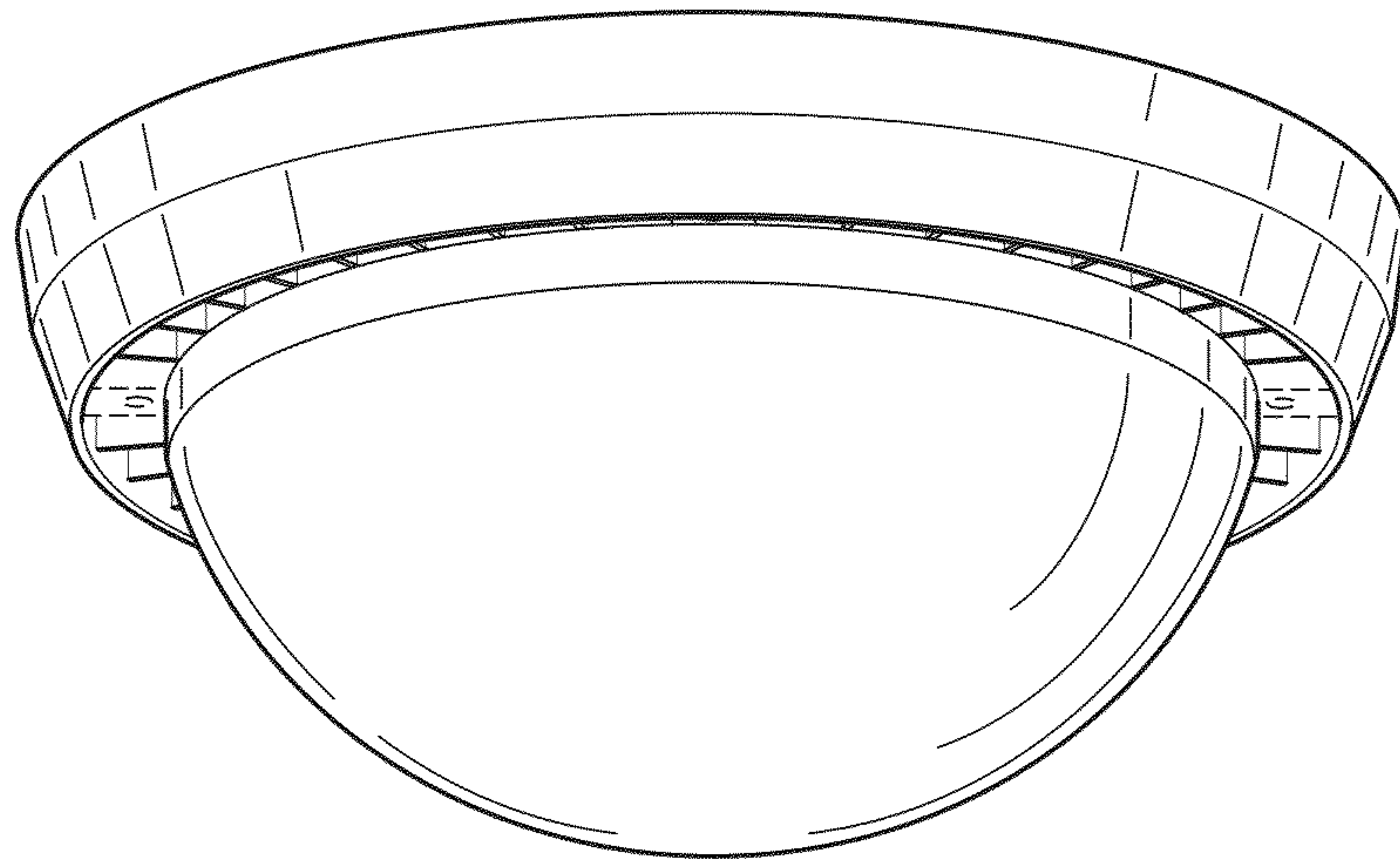
**FIG. 19**



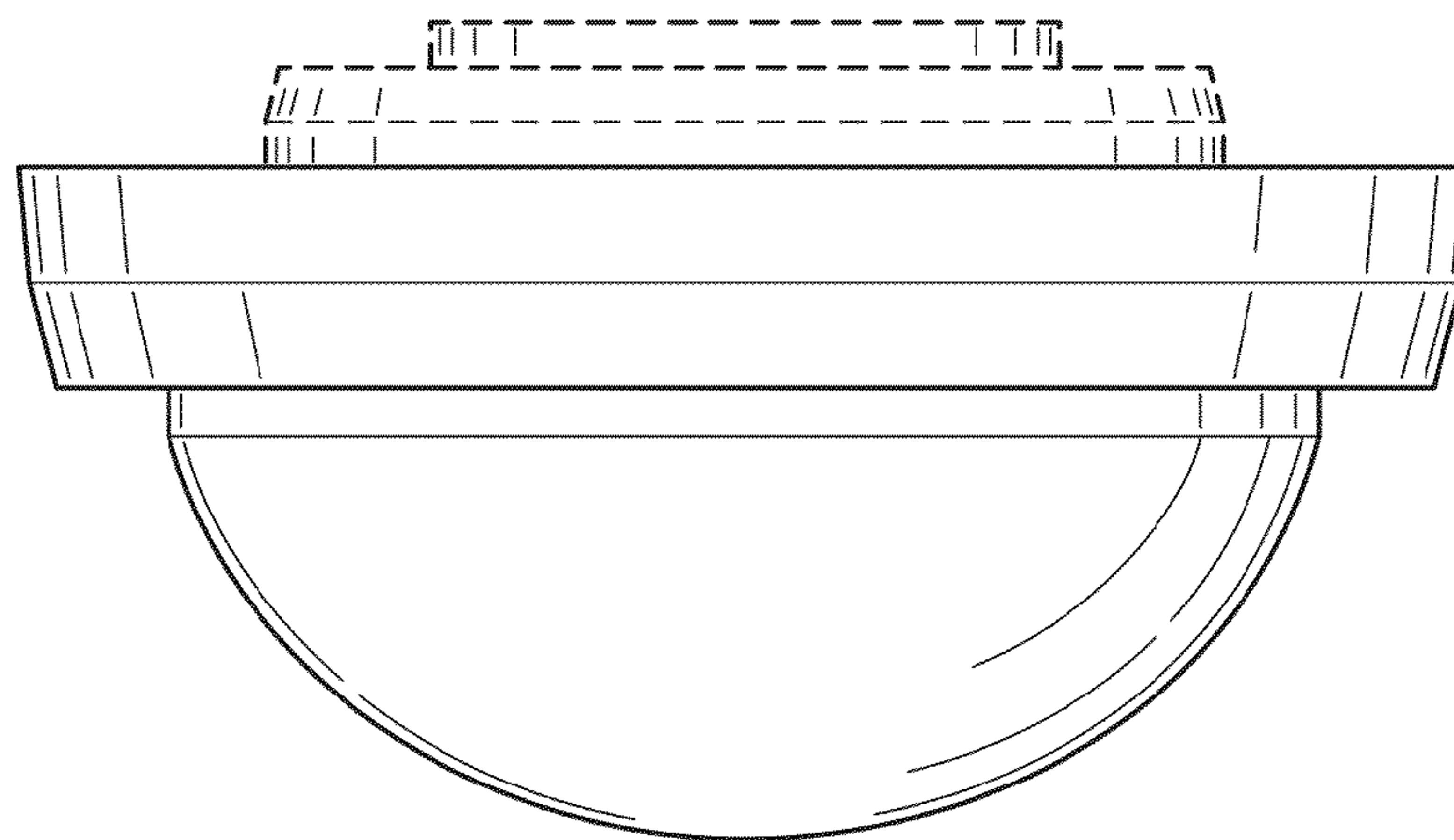
**FIG. 20**



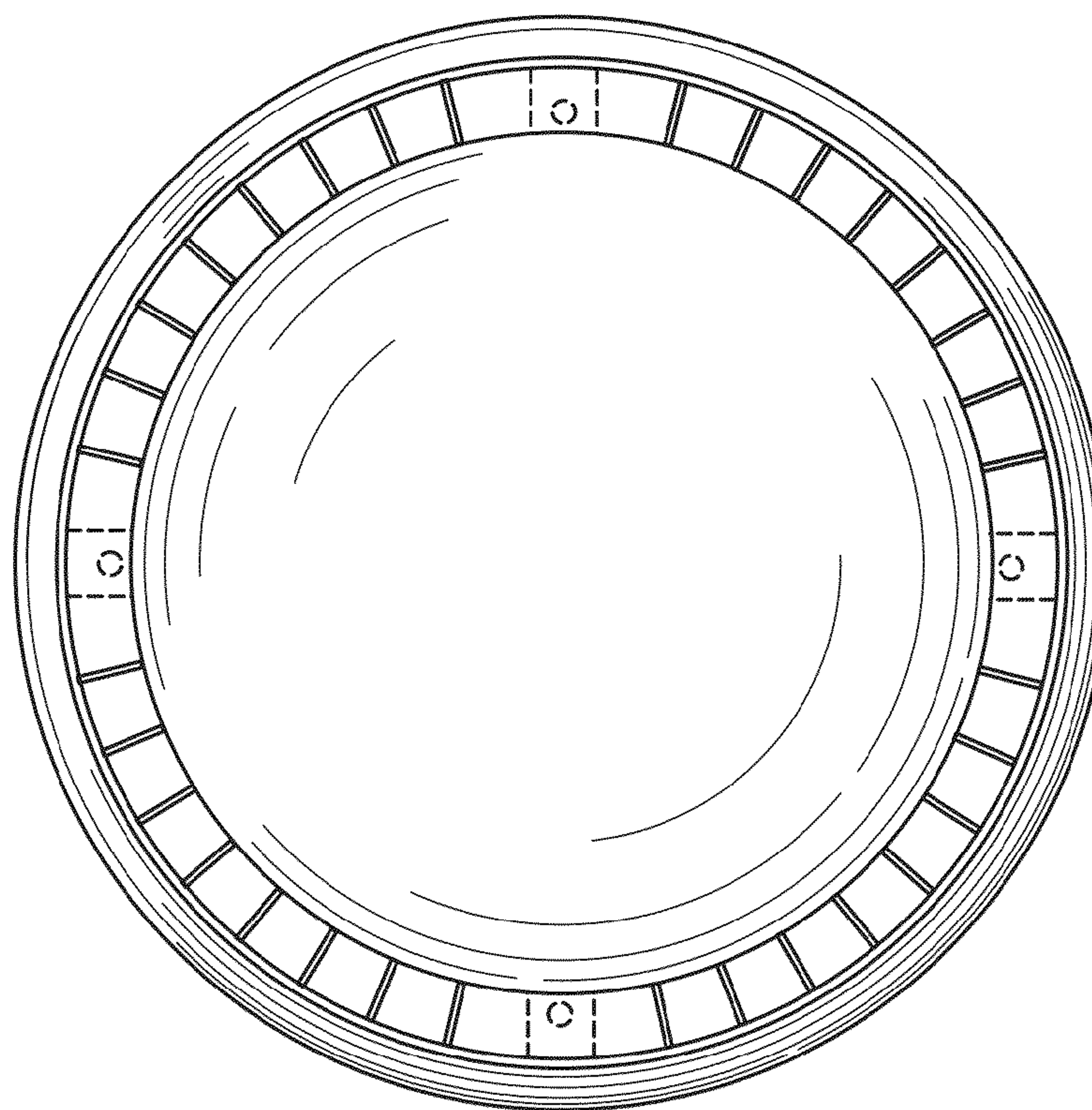
**FIG. 21**

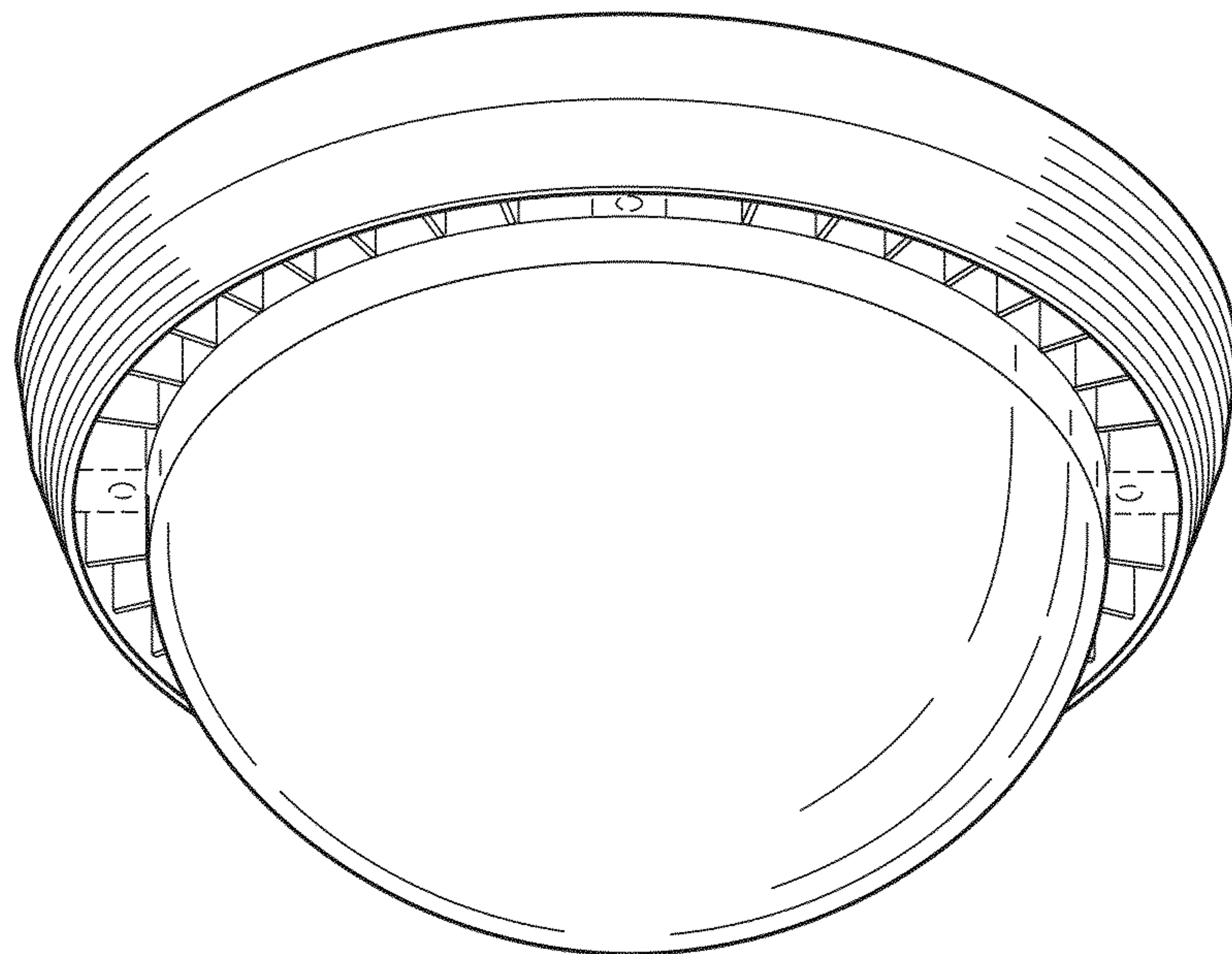


**FIG. 22**

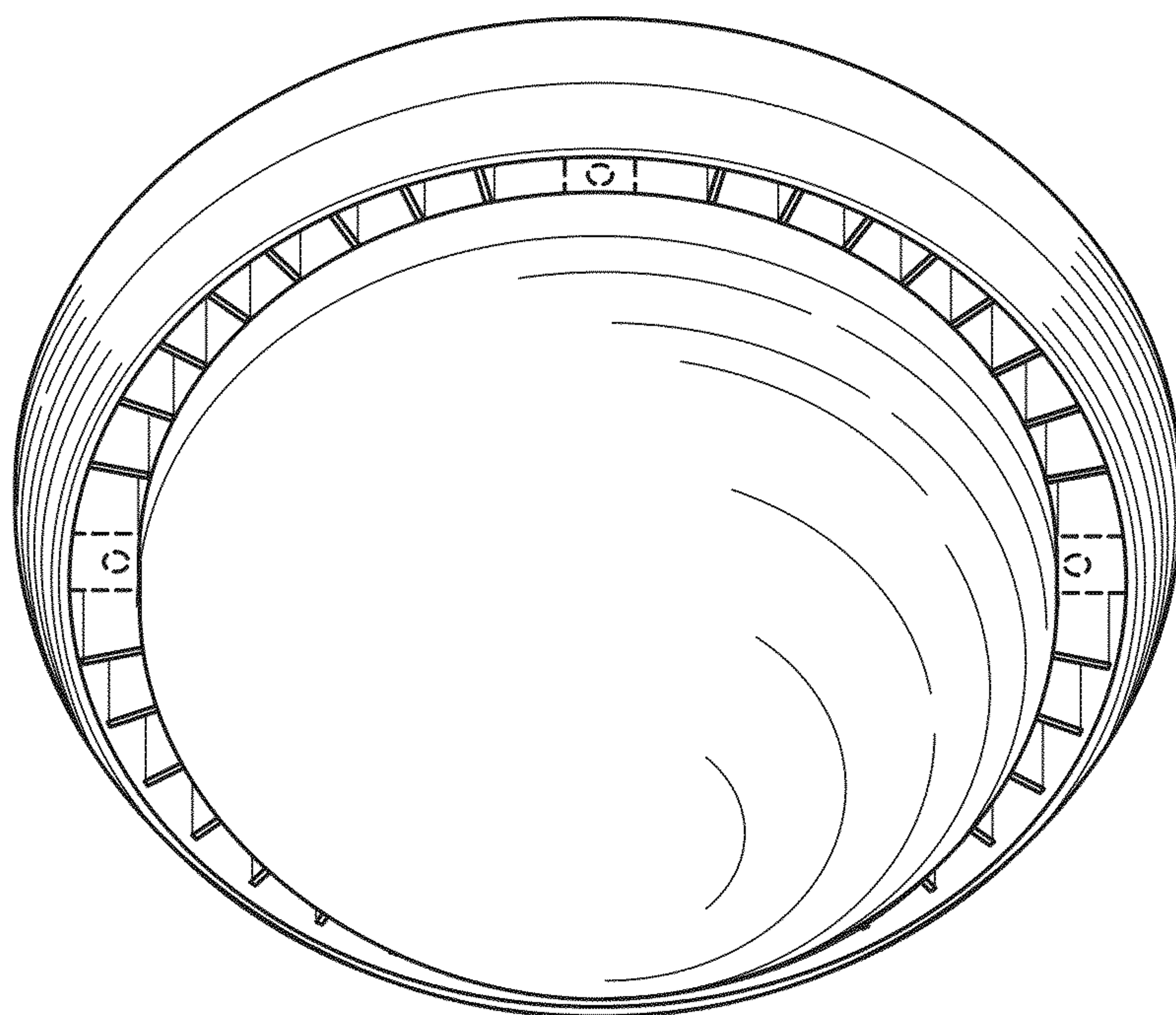


**FIG. 23**





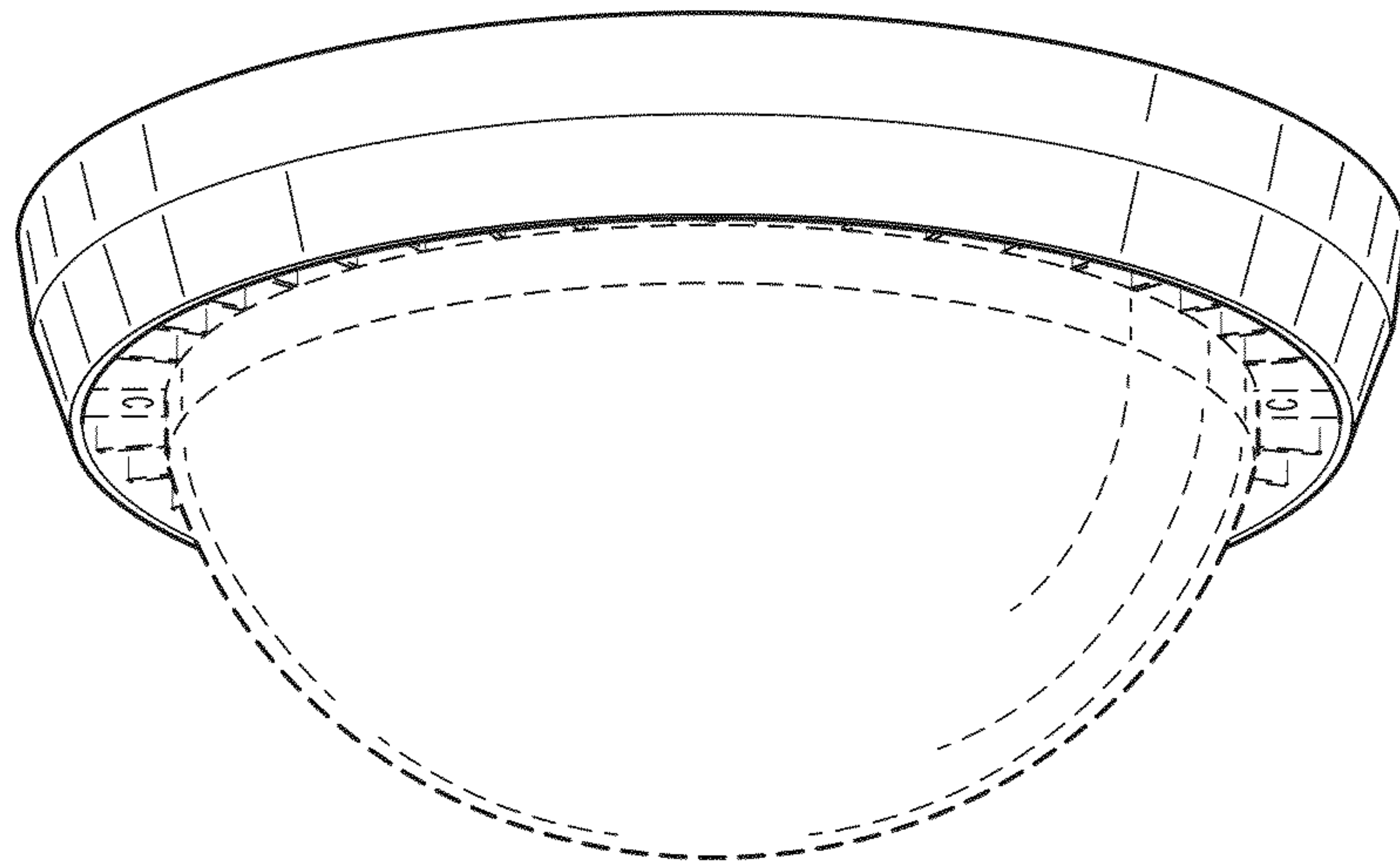
**FIG. 24**



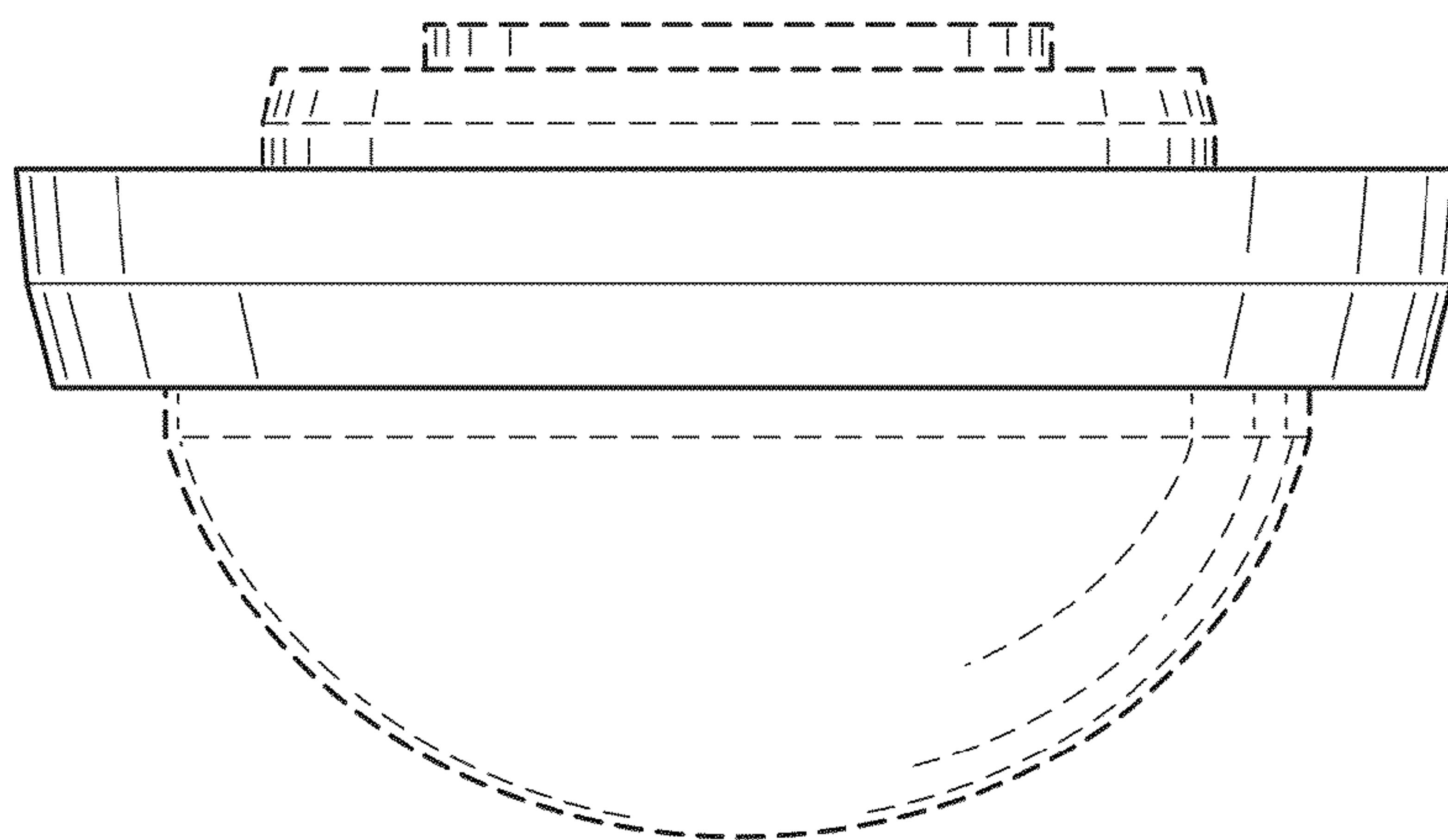
**FIG. 25**



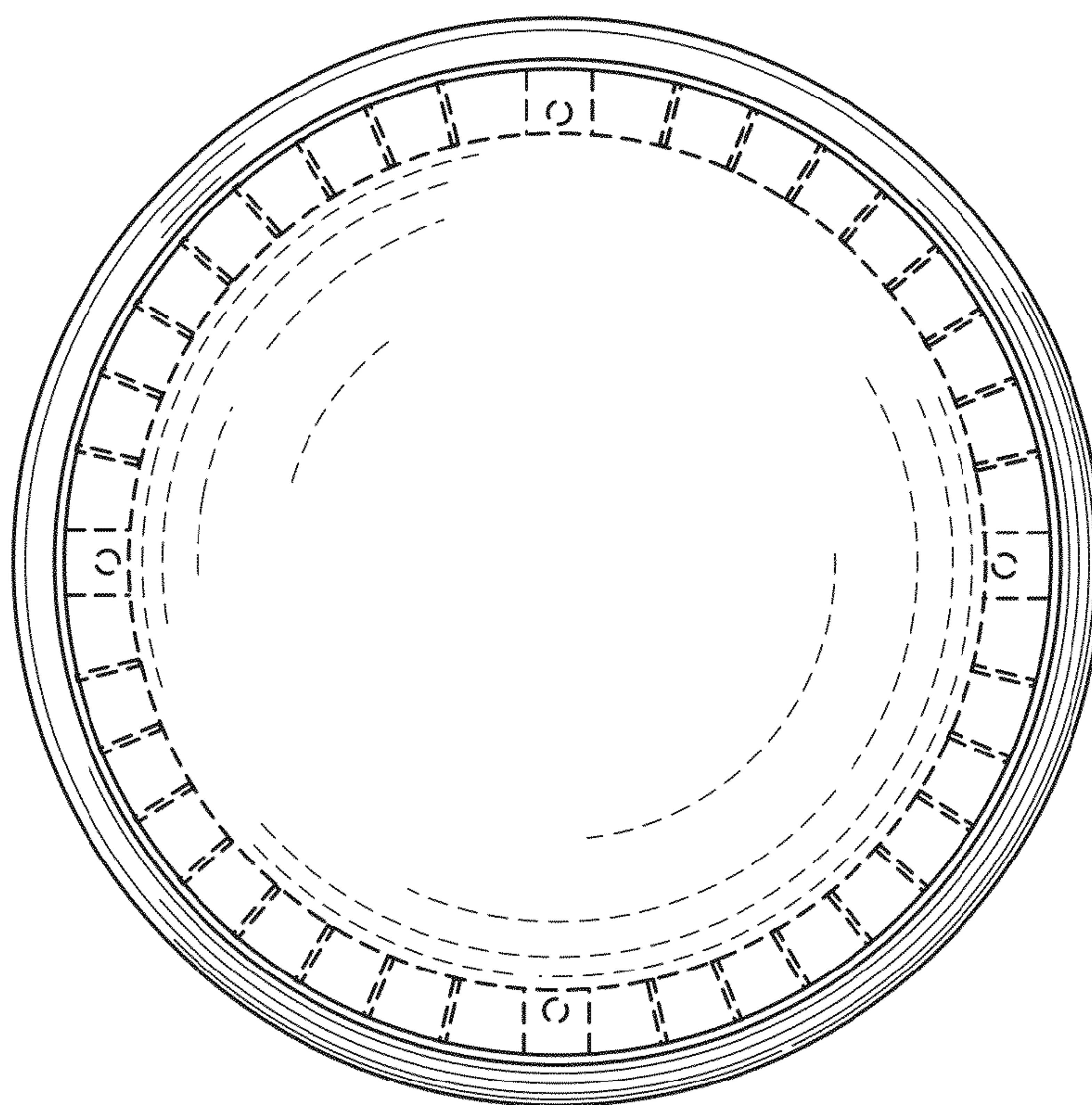
**FIG. 26**

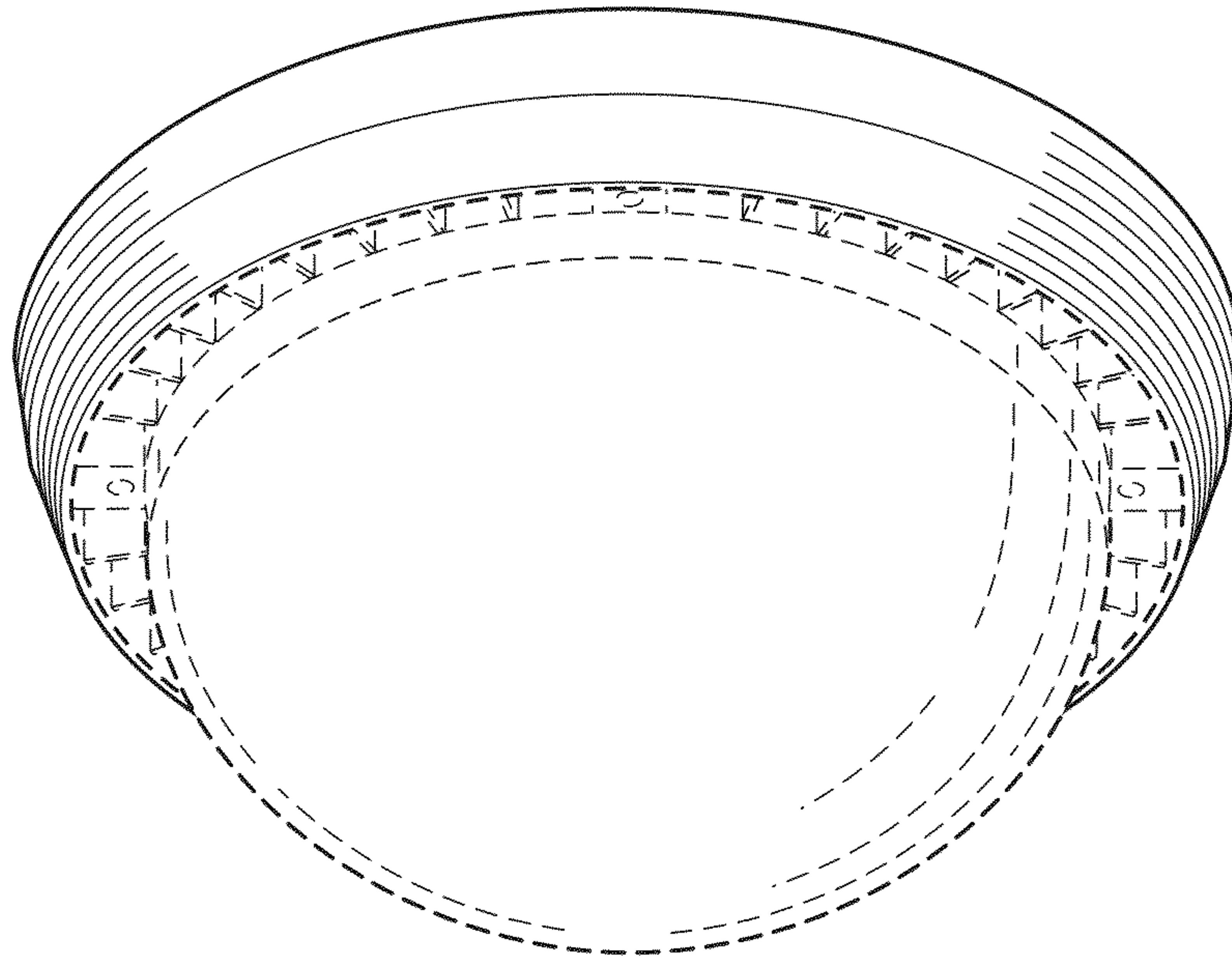


**FIG. 27**

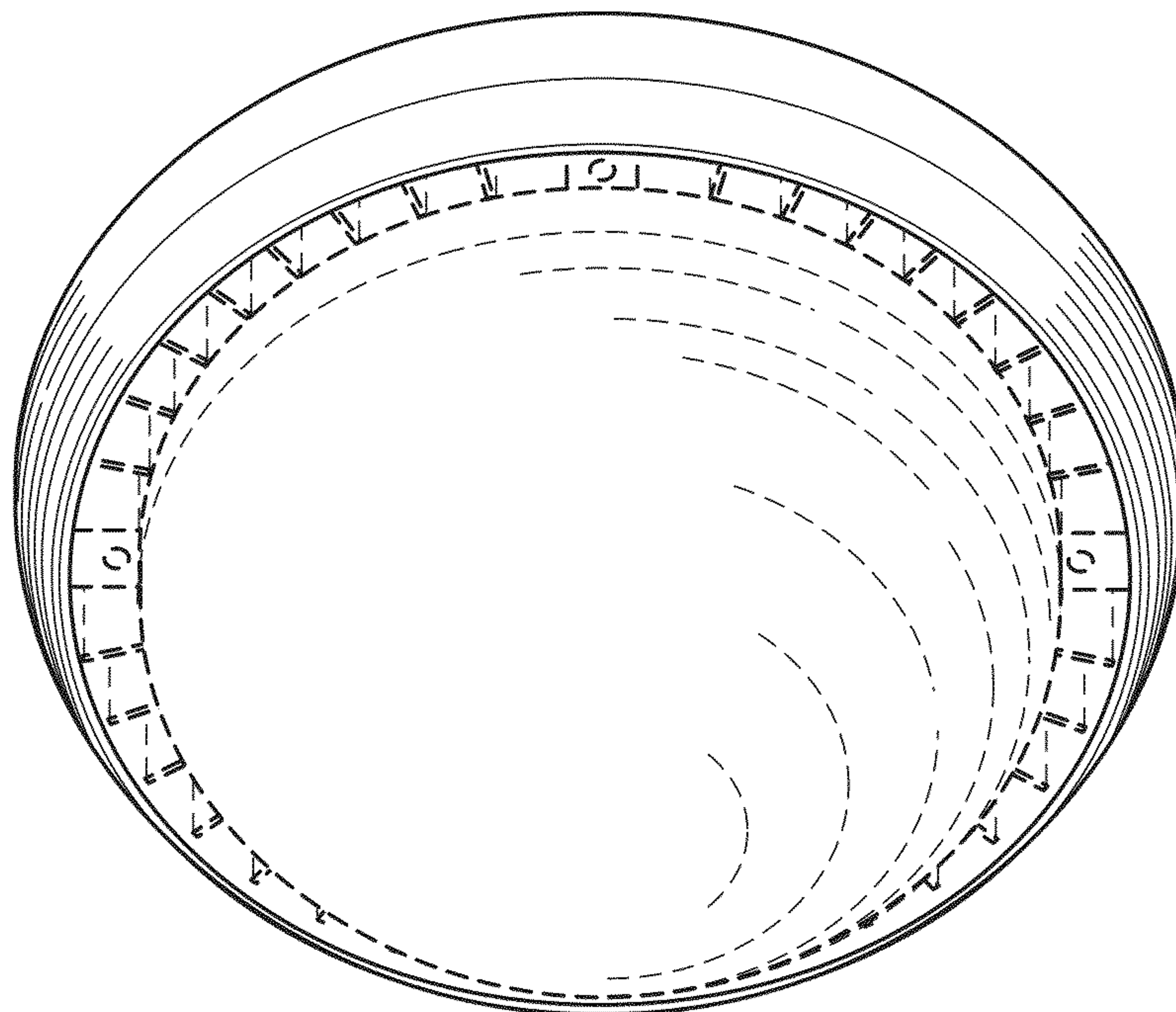


**FIG. 28**





**FIG. 29**



**FIG. 30**