



US00D706692S

(12) **United States Design Patent**  
**Wheel et al.**

(10) **Patent No.:** **US D706,692 S**  
(45) **Date of Patent:** **\*\* Jun. 10, 2014**

(54) **VEHICLE COMPONENT**

FOREIGN PATENT DOCUMENTS

(71) Applicant: **Jaguar Land Rover Limited**, Coventry (GB)

EM 000071220-0007 \* 9/2003  
EM 0020000414-0002 \* 2/2012

(72) Inventors: **Andrew Wheel**, Coventry (GB); **Jeremy Waterman**, Coventry (GB)

OTHER PUBLICATIONS

(73) Assignee: **Jaguar Land Rover Limited** (GB)

(\*\*) Term: **14 Years**

(21) Appl. No.: **29/466,419**

(22) Filed: **Sep. 6, 2013**

(30) **Foreign Application Priority Data**

Mar. 8, 2013 (EM) ..... 002199216

(51) **LOC (10) Cl.** ..... **12-16**

(52) **U.S. Cl.**  
USPC ..... **D12/196**

(58) **Field of Classification Search**  
USPC ..... D12/169, 196, 171, 216, 90-92, 86;  
296/180.1, 180.2; 293/102, 113, 115,  
293/117, 120  
See application file for complete search history.

Range Rover Sport, announced Mar. 26, 2013, [online], [site visited Dec. 4, 2013]. Available from Internet, <URL: http://www.landrover.com/us/en/lr/#>.\*

2012 Land Rover Range Rover Evoque, article date Dec. 2011, [online], [site visited Dec. 5, 2013]. Available from internet, <URL:http://www.motortrend.com/oftheyear/suv/1112\_2012\_suv\_of\_the\_year\_land\_rover\_range\_rover\_evoque/>.\*

2013 Land Rover Range Rover, article date Nov. 2012, [online], [site visited Dec. 5, 2013]. Available from internet, <URL: http://www.motortrend.com/roadtests/suvs/1211\_2013\_range\_rover\_first\_drive/>.\*

\* cited by examiner

*Primary Examiner* — Eric Goodman

*Assistant Examiner* — Jennifer Watkins

(74) *Attorney, Agent, or Firm* — Rader, Fishman & Grauer PLLC

(57) **CLAIM**

The ornamental design for a vehicle component, as shown and described.

(56) **References Cited**

**DESCRIPTION**

U.S. PATENT DOCUMENTS

- D374,415 S \* 10/1996 Thomson ..... D12/91
- D458,189 S \* 6/2002 Wyatt ..... D12/91
- D468,237 S \* 1/2003 Murkett ..... D12/91
- D494,913 S \* 8/2004 Chapman ..... D12/196
- D556,662 S \* 12/2007 Murkett ..... D12/196
- D556,663 S \* 12/2007 Murkett ..... D12/196
- D630,972 S \* 1/2011 Fujiwara et al. .... D12/91
- D641,291 S \* 7/2011 Sperling et al. .... D12/91
- D650,313 S \* 12/2011 Fetherston et al. .... D12/164
- D668,999 S \* 10/2012 Ito et al. .... D12/91
- D670,621 S \* 11/2012 Frenzel et al. .... D12/164
- D693,737 S \* 11/2013 Hammoud et al. .... D12/91
- 2012/0169085 A1 \* 7/2012 Verhee et al. .... 296/180.1

FIG. 1 is a left rear perspective view of a rear portion of a vehicle;  
FIG. 2 is a right rear perspective view of a rear portion of a vehicle;  
FIG. 3 is a left side view of a rear portion of a vehicle;  
FIG. 4 is a right side view of a rear portion of a vehicle; and,  
FIG. 5 is a rear view of a rear portion of a vehicle.  
Portions of FIGS. 1-5 that are shown with diagonal lines are for illustrative purpose only and form no part of the claimed design.

**1 Claim, 5 Drawing Sheets**

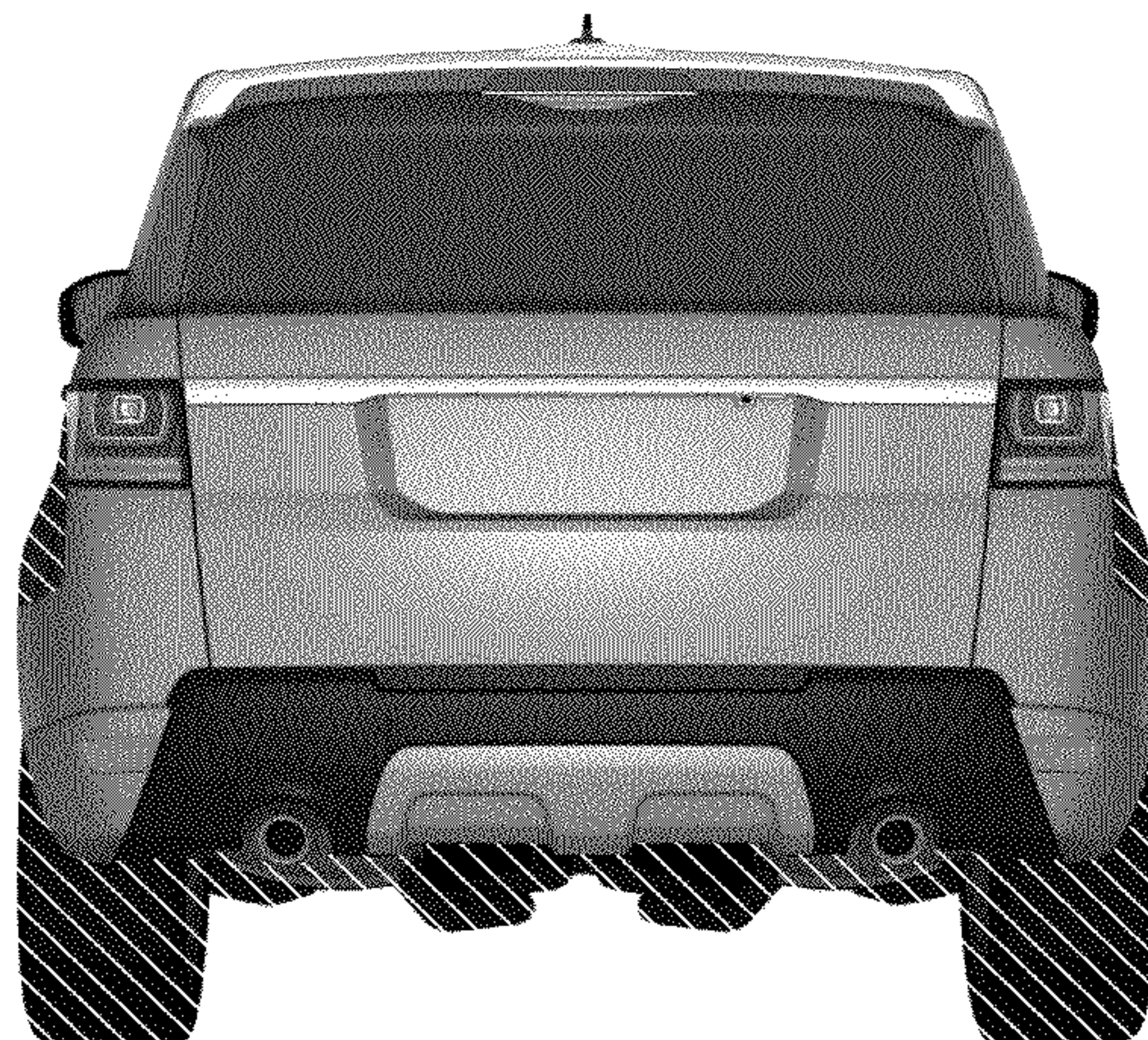





FIG. 1



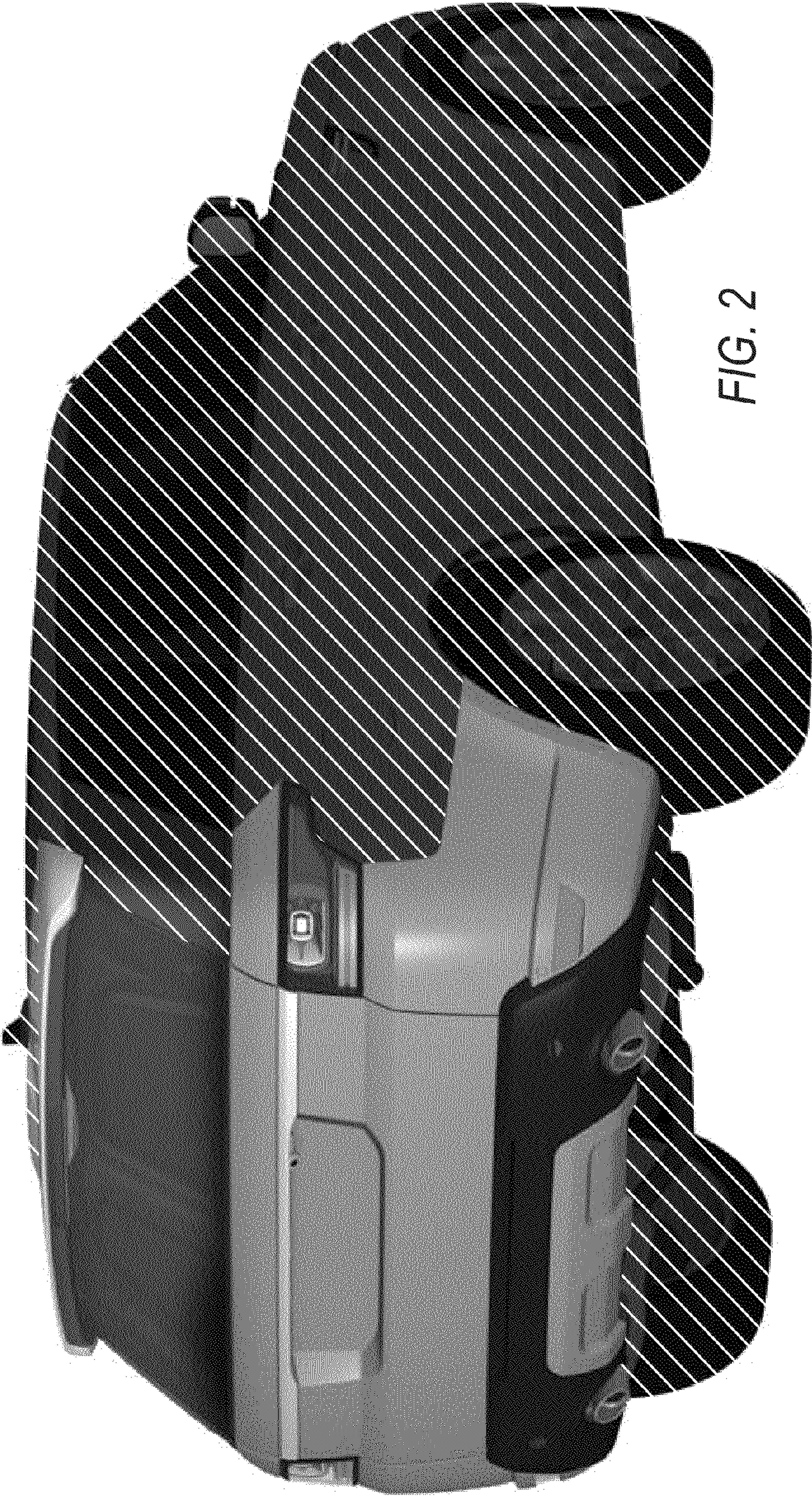

FIG. 2



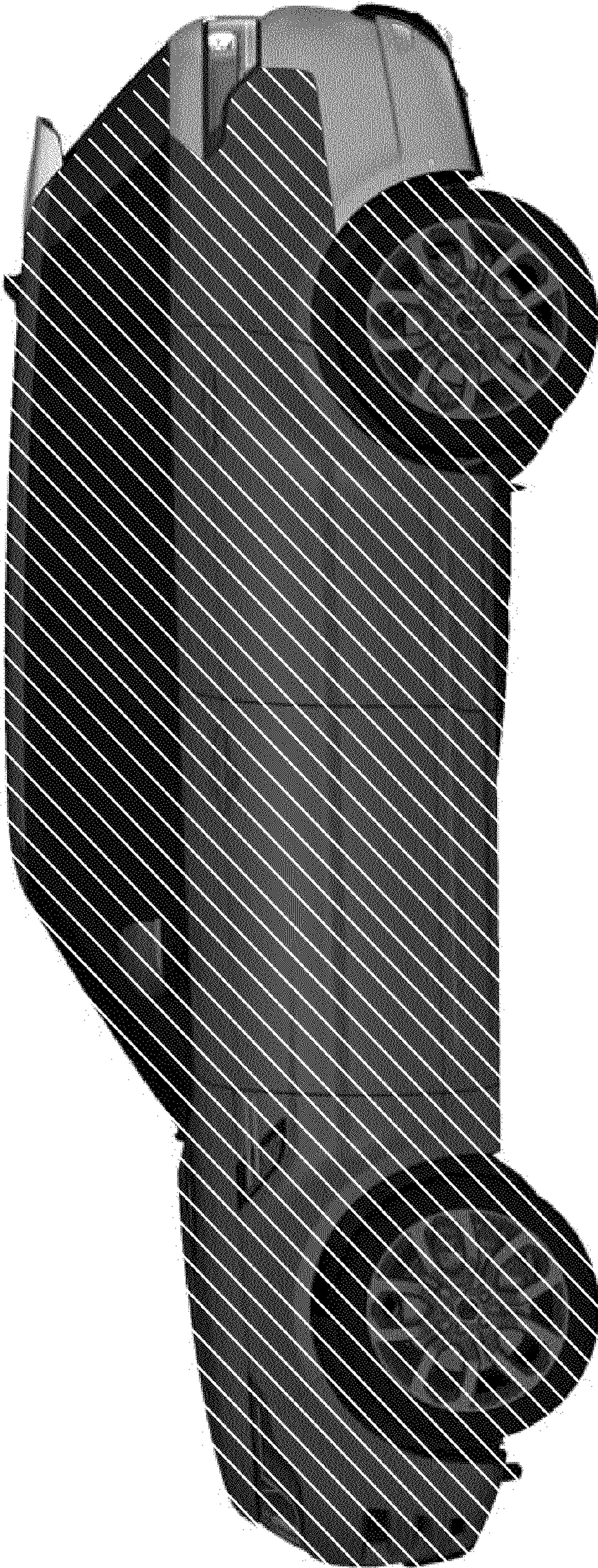

FIG. 3



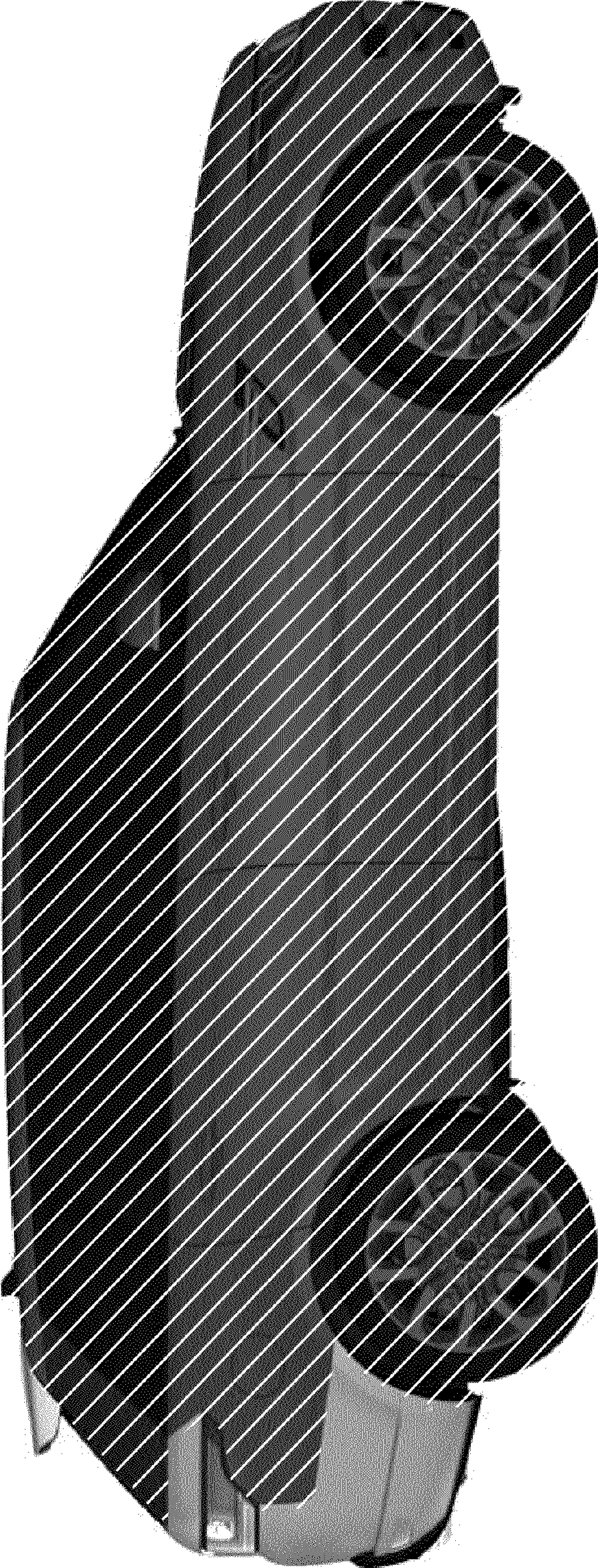

FIG. 4





FIG. 5