



US00D706559S

(12) **United States Design Patent**  
**Muller**

(10) **Patent No.:** **US D706,559 S**  
(45) **Date of Patent:** **\*\* Jun. 10, 2014**

- (54) **BOOKCASE**
- (71) Applicant: **Elite Manufacturing Corporation**,  
Santa Fe Springs, CA (US)
- (72) Inventor: **Carl Muller**, Huntington Beach, CA  
(US)
- (73) Assignee: **Elite Manufacturing Corporation**,  
Santa Fe Springs, CA (US)

5,035,334 A *	7/1991	Messick, Jr.	211/134
D364,763 S *	12/1995	Sielaff	D6/479
D401,084 S *	11/1998	Martin	D6/474
D431,937 S *	10/2000	Heiny et al.	D6/479
D433,846 S *	11/2000	Chang	D6/474
D492,861 S *	7/2004	Lenger	D6/474
D492,862 S *	7/2004	Gay, II	D6/479
D547,585 S *	7/2007	Netto et al.	D6/574
D560,402 S *	1/2008	Lev	D6/479
D617,121 S *	6/2010	Walsh	D6/477
D633,313 S *	3/2011	Ma	D6/397
D638,639 S *	5/2011	Ma	D6/449
D657,591 S *	4/2012	Sanchez	D6/479

(\*\*) Term: **14 Years**

\* cited by examiner

(21) Appl. No.: **29/478,386**

*Primary Examiner* — Kelley Donnelly

(22) Filed: **Jan. 3, 2014**

(74) *Attorney, Agent, or Firm* — Stetina Brunda Garred & Brucker

(51) **LOC (10) Cl.** ..... **06-06**

(52) **U.S. Cl.**  
USPC ..... **D6/678.1**

(57) **CLAIM**

The ornamental design for a bookcase, as shown and described.

(58) **Field of Classification Search**  
USPC ..... D6/460–461, 468, 474, 477–479, 407,  
D6/675, 675.1–675.3, 678, 678.1;  
108/59–60, 91–92, 147.11, 149;  
211/153, 186, 188, 194; 312/9.1, 7.2,  
312/223.1

**DESCRIPTION**

See application file for complete search history.

FIG. 1 is a front perspective view of the bookcase of the present invention showing my new design; FIG. 2 is a top plan view thereof; FIG. 3 is a front elevational view thereof; FIG. 4 is a left side elevational view thereof; FIG. 5 is a bottom plan view thereof; and, FIG. 6 is a rear elevational view thereof.

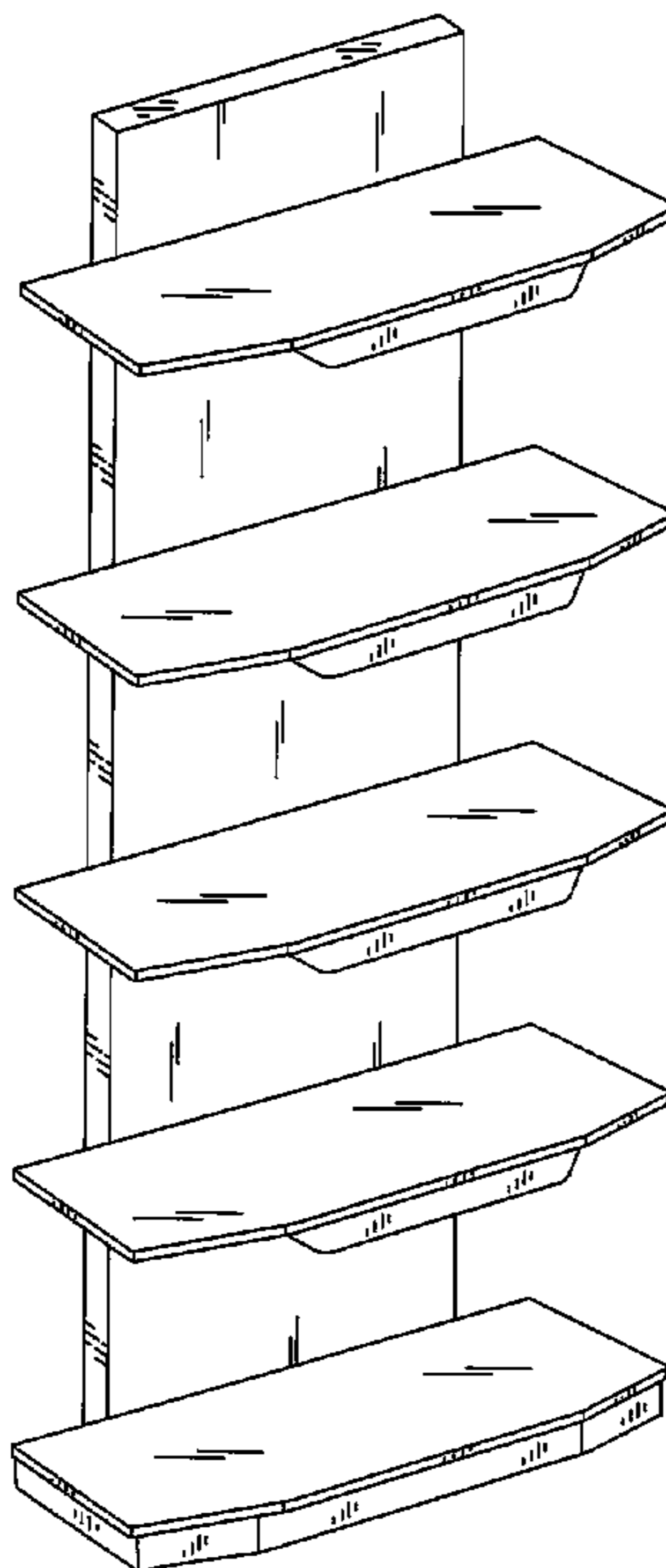
The broken lines are for the purpose of illustrating the environment of the article only and form no part of the claimed design.

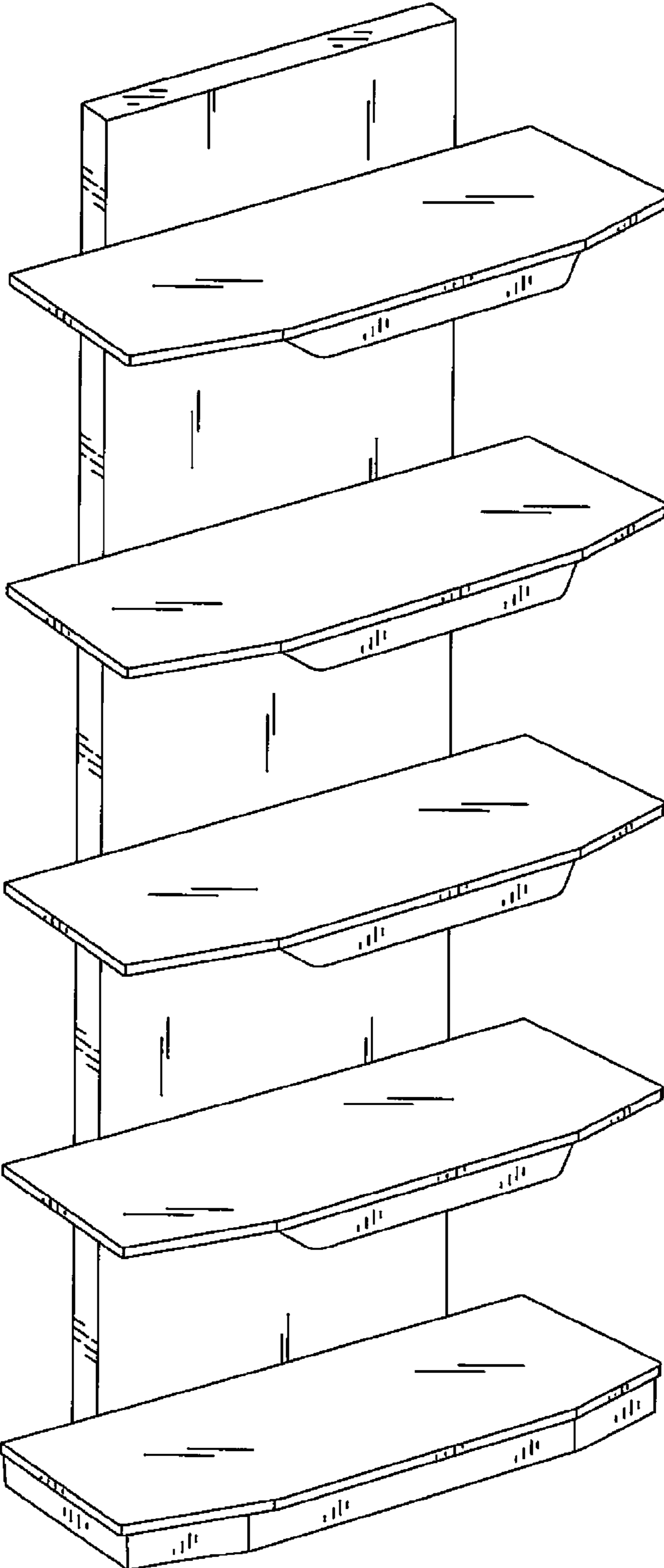
(56) **References Cited**

**U.S. PATENT DOCUMENTS**

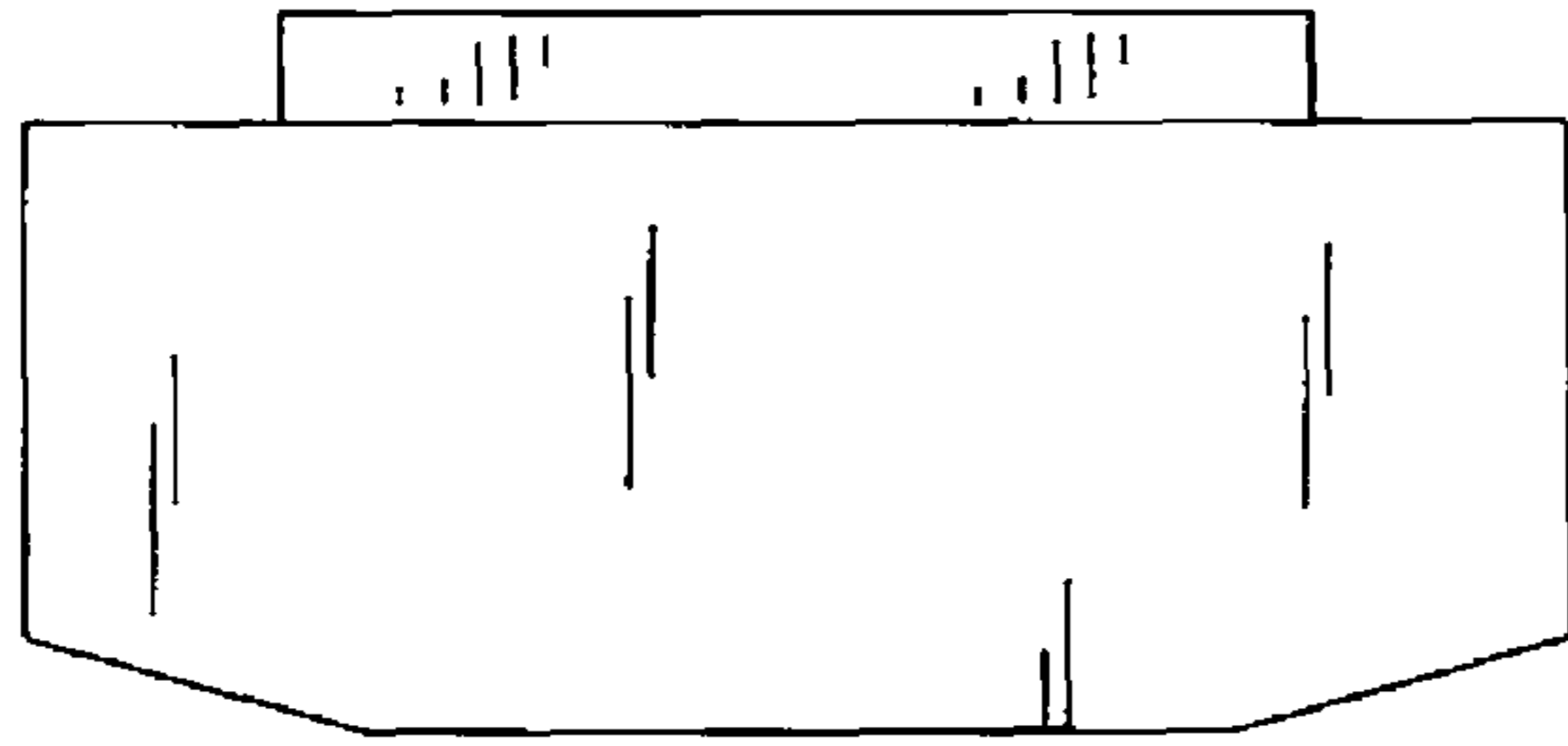
D243,891 S *	4/1977	Snyder	D6/431
D269,754 S *	7/1983	Kates	D6/429
4,620,489 A *	11/1986	Albano	108/105
4,785,946 A *	11/1988	Sorensen	211/187

**1 Claim, 3 Drawing Sheets**

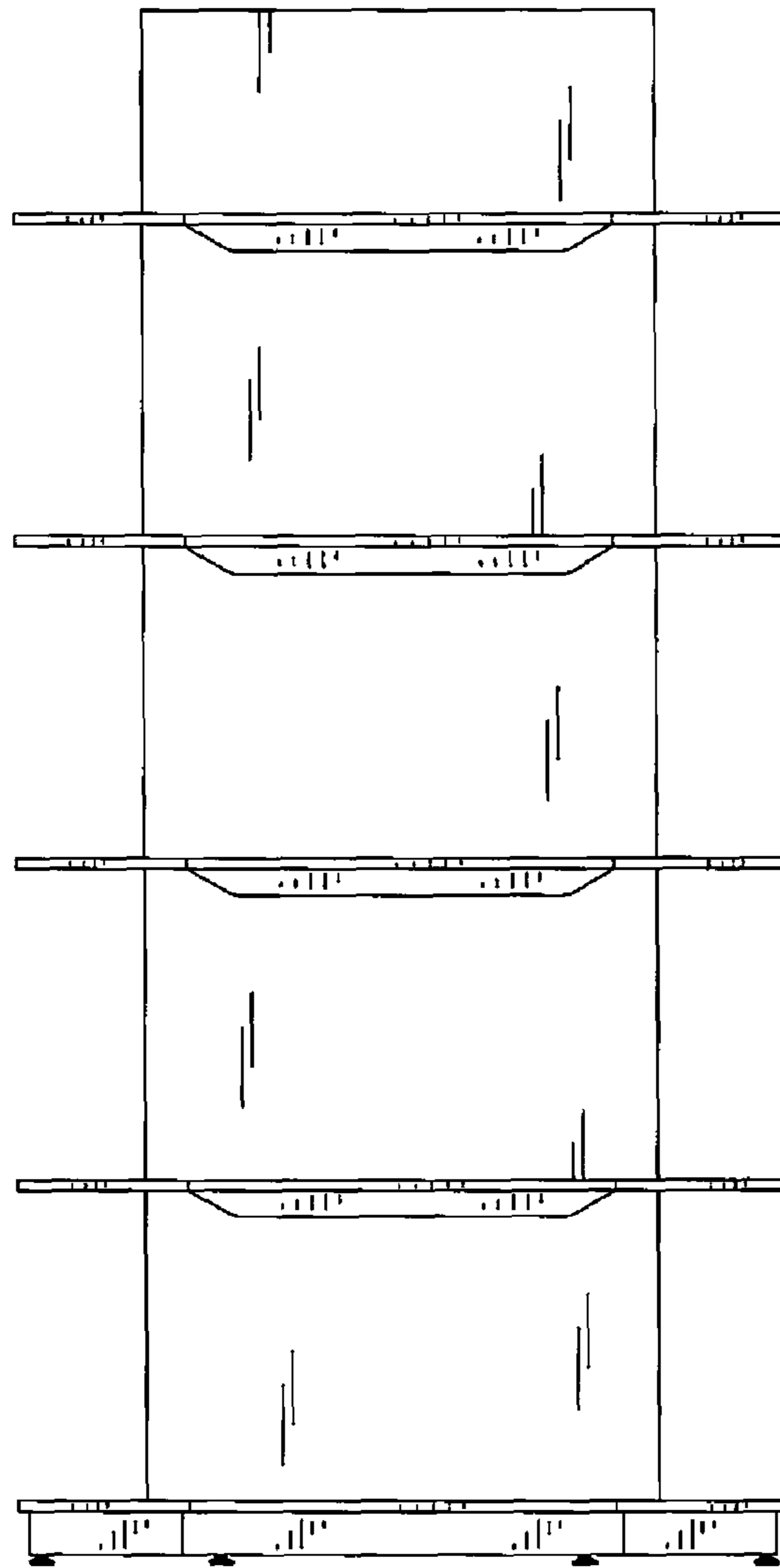




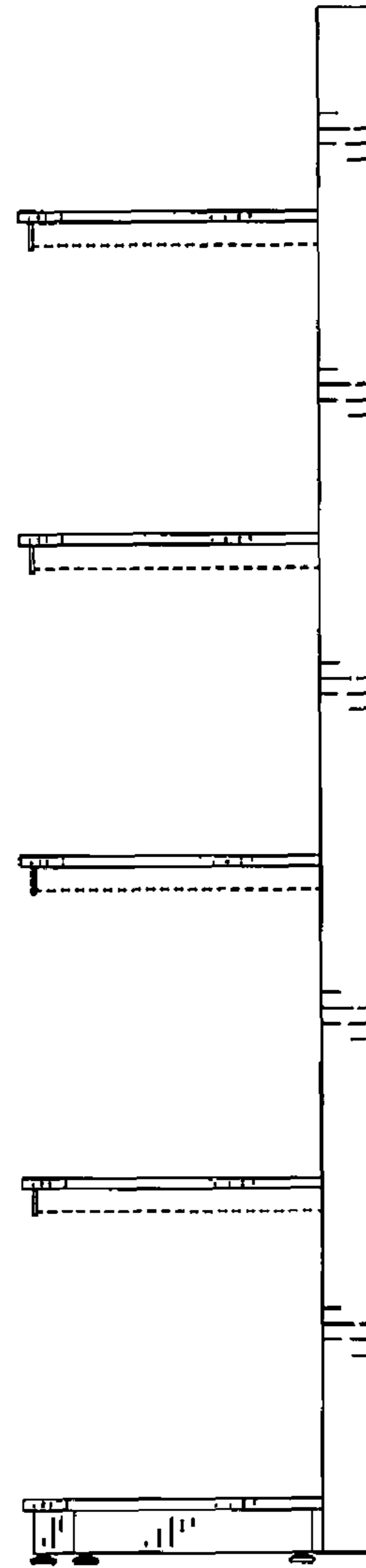
*Fig. 1*



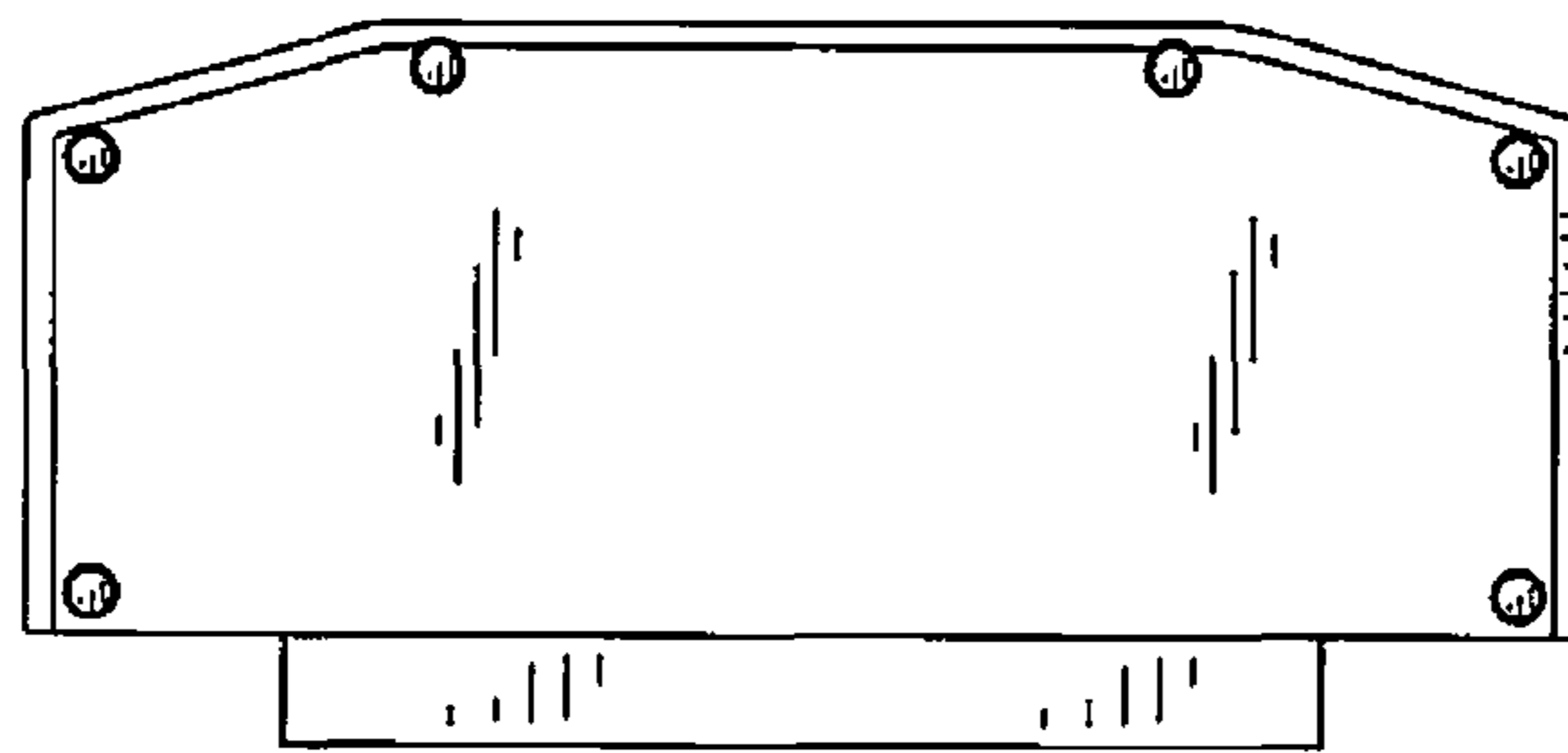
*Fig. 2*



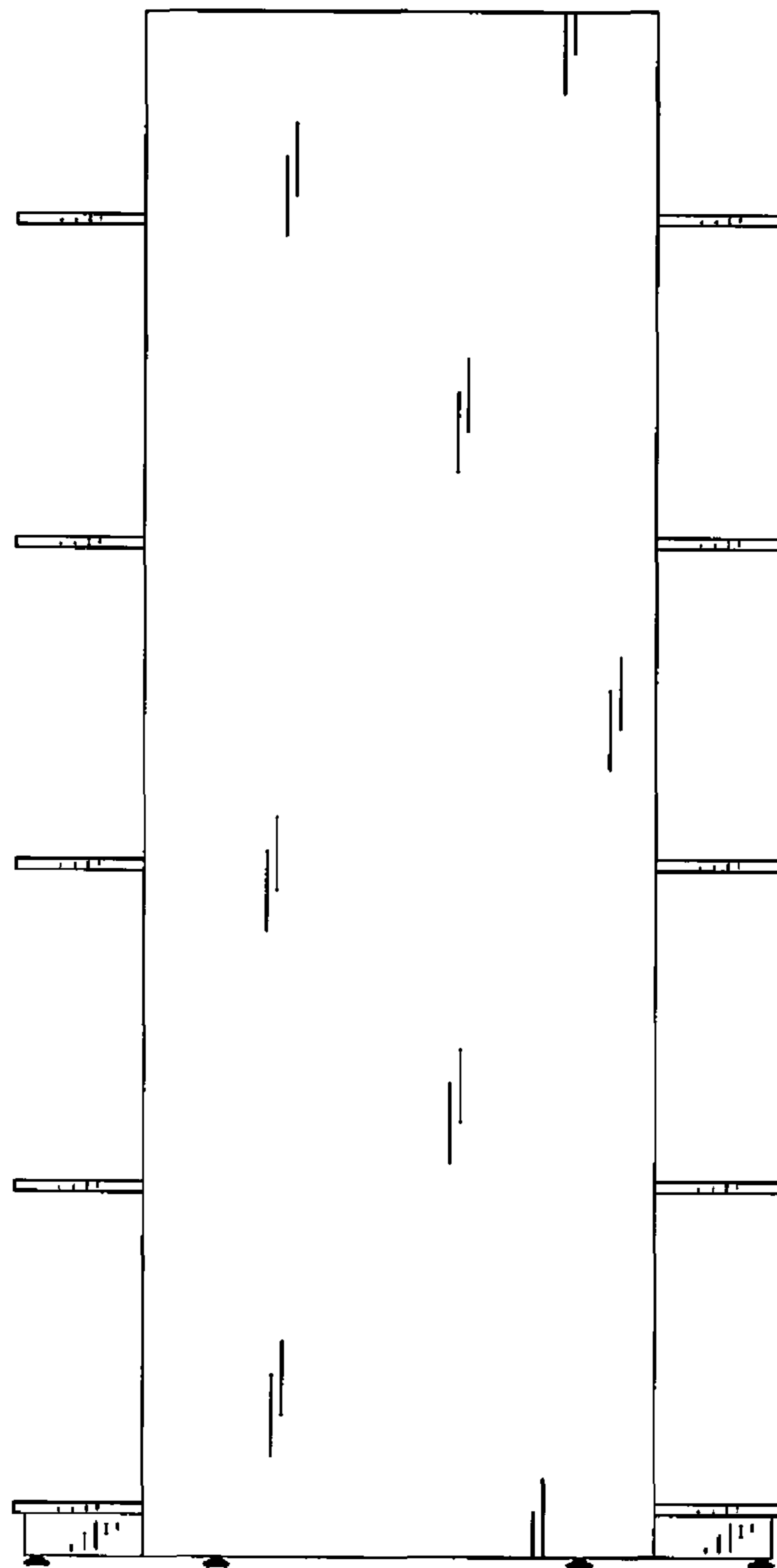
*Fig. 3*



*Fig. 4*



*Fig. 5*



*Fig. 6*