



US00D706485S

(12) **United States Design Patent**  
**Waldmann**

(10) **Patent No.:** **US D706,485 S**  
(45) **Date of Patent:** **\*\* Jun. 3, 2014**

(54) **LAMP**

(71) Applicant: **Gerhard Waldmann**, Stein am Rhein  
(CH)

(72) Inventor: **Gerhard Waldmann**, Stein am Rhein  
(CH)

(73) Assignee: **Herbert Waldmann GmbH & Co. KG**,  
Villingen-Schwenningen (DE)

(\*\*) Term: **14 Years**

(21) Appl. No.: **29/444,215**

(22) Filed: **Jan. 28, 2013**

(30) **Foreign Application Priority Data**

Aug. 13, 2012 (WO) ..... DM/079 031

(51) **LOC (10) Cl.** ..... **26-99**

(52) **U.S. Cl.**  
USPC ..... **D26/138**

(58) **Field of Classification Search**  
USPC ..... D26/3, 24, 35, 39, 42, 71, 72, 75, 76,  
D26/78, 79, 80, 81, 82, 83, 85, 88, 90, 118,  
D26/119, 120, 121, 122, 138; 362/23.07,  
362/23.09, 23.16, 217.01, 217.02, 217.05,  
362/217.08, 217.09, 249.02, 260, 311.02,  
362/555, 612, 614, 800

See application file for complete search history.

(56) **References Cited**

**U.S. PATENT DOCUMENTS**

D123,761 S \* 12/1940 Pieper ..... D26/24  
D262,659 S \* 1/1982 Latta et al. .... D26/35  
D312,978 S \* 12/1990 Foster ..... D26/35

D326,621 S \* 6/1992 Jincks et al. .... D26/35  
D345,316 S \* 3/1994 Green et al. .... D26/35  
D399,587 S \* 10/1998 Compton et al. .... D26/76  
D466,244 S \* 11/2002 Lewis et al. .... D26/76  
D476,753 S \* 7/2003 Chelf et al. .... D26/3  
D521,172 S \* 5/2006 Chen ..... D26/76  
D576,332 S \* 9/2008 Ruud et al. .... D26/72  
D609,841 S \* 2/2010 Bush ..... D26/76  
D636,108 S \* 4/2011 Nguyen et al. .... D26/76  
D669,204 S \* 10/2012 Snell et al. .... D26/76  
2013/0021792 A1 \* 1/2013 Snell et al. .... 362/218

\* cited by examiner

*Primary Examiner* — Deanna L Pratt

*Assistant Examiner* — Natasha Vujcic

(74) *Attorney, Agent, or Firm* — Andrew F. Young, Esq.;  
Lackebach Siegel, LLP

(57) **CLAIM**

The ornamental design for a lamp, as shown and described.

**DESCRIPTION**

FIG. 1 is a front perspective view of the invention.

FIG. 2 is a top plan view of FIG. 1.

FIG. 3 is a bottom plan view of FIG. 1.

FIG. 4 is a right side elevation view of FIG. 1.

FIG. 5 is a left side elevation view of FIG. 1.

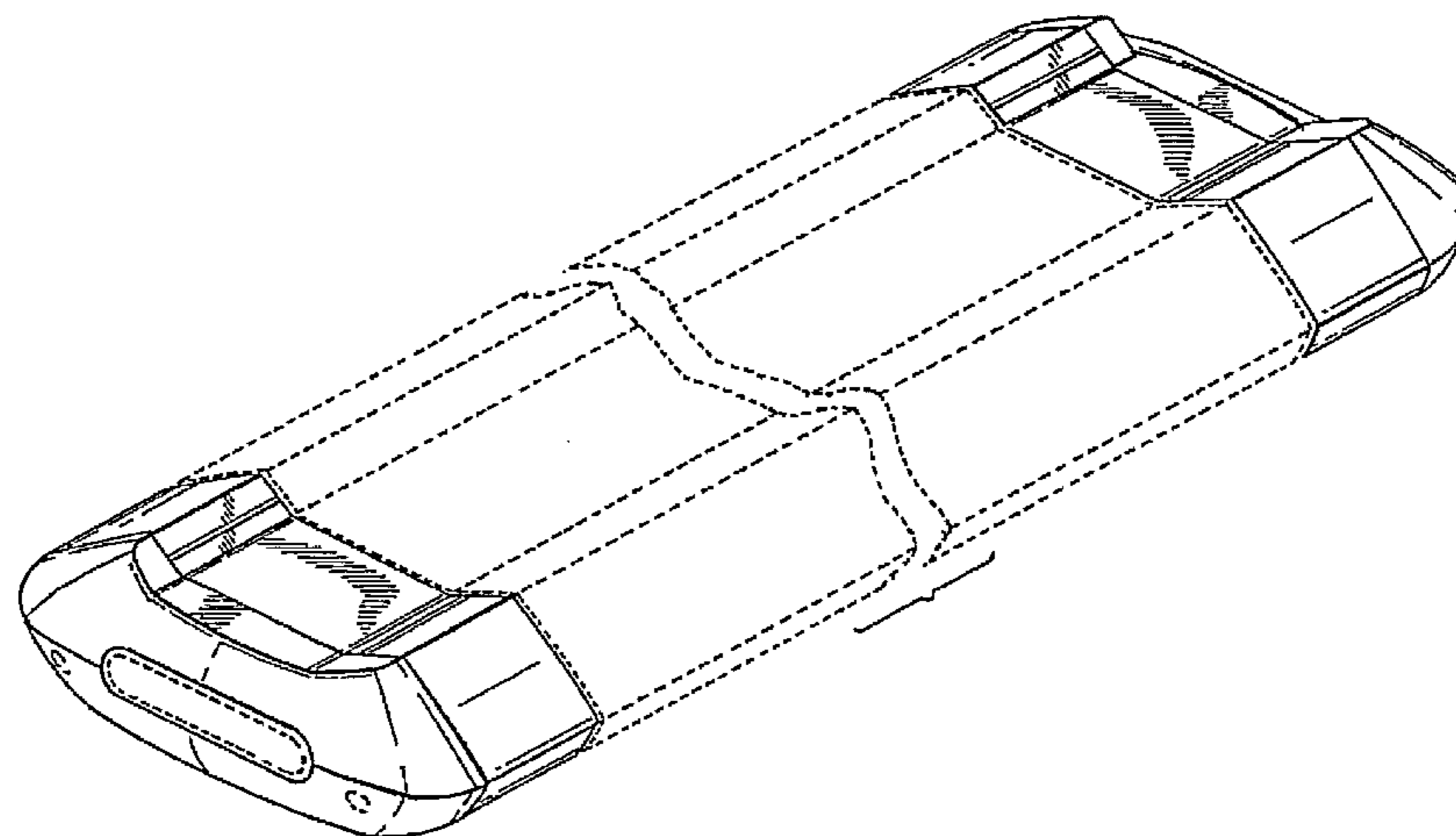
FIG. 6 is a front elevation view of FIG. 1; and,

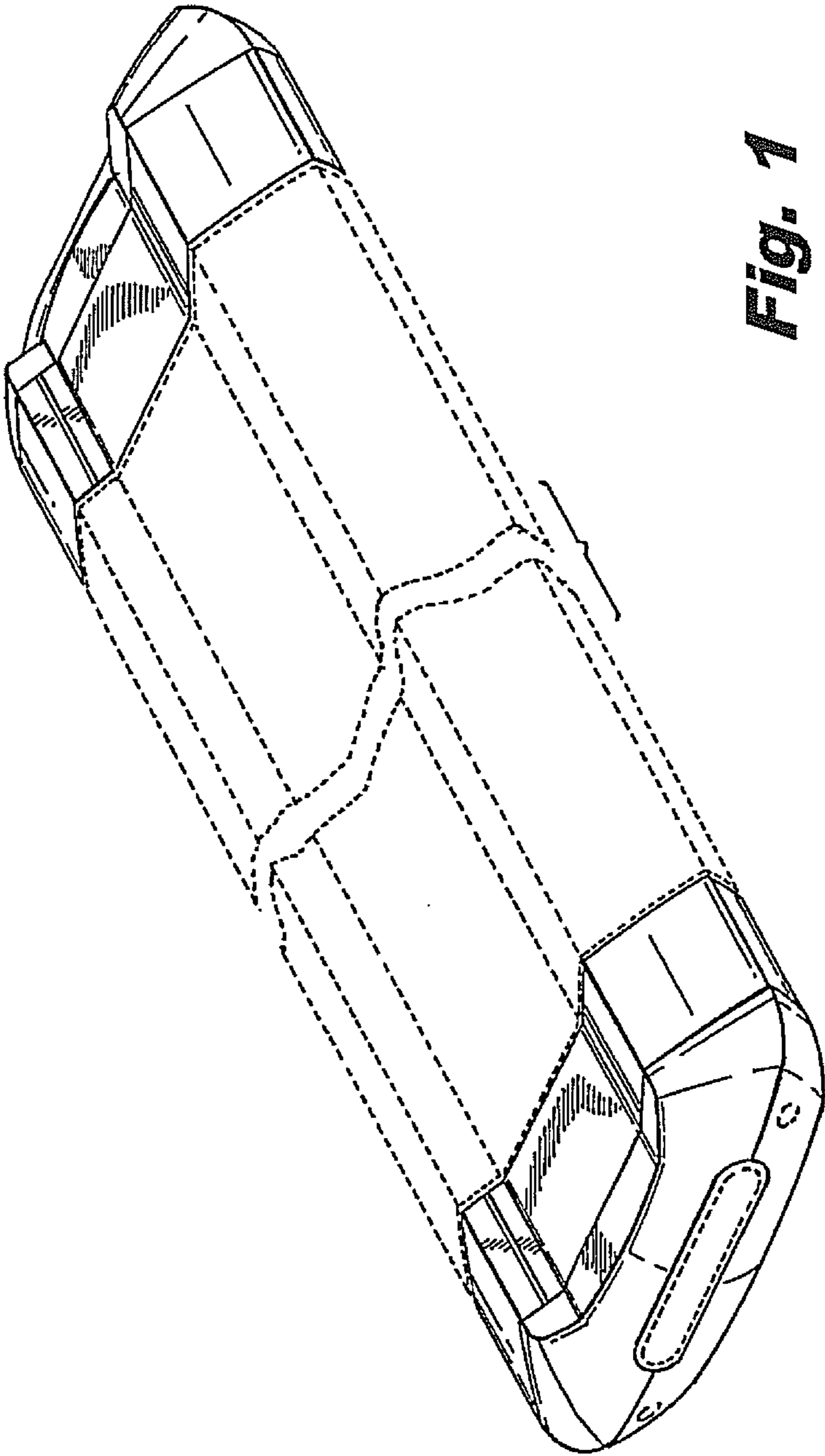
FIG. 7 is a rear elevation view of FIG. 1.

The broken lines in the drawings illustrate portions of the lamp which form no part of the claimed design, and these include without limitation: the central regions between the end portions, portions on either end, screw-hole features, and switch feature.

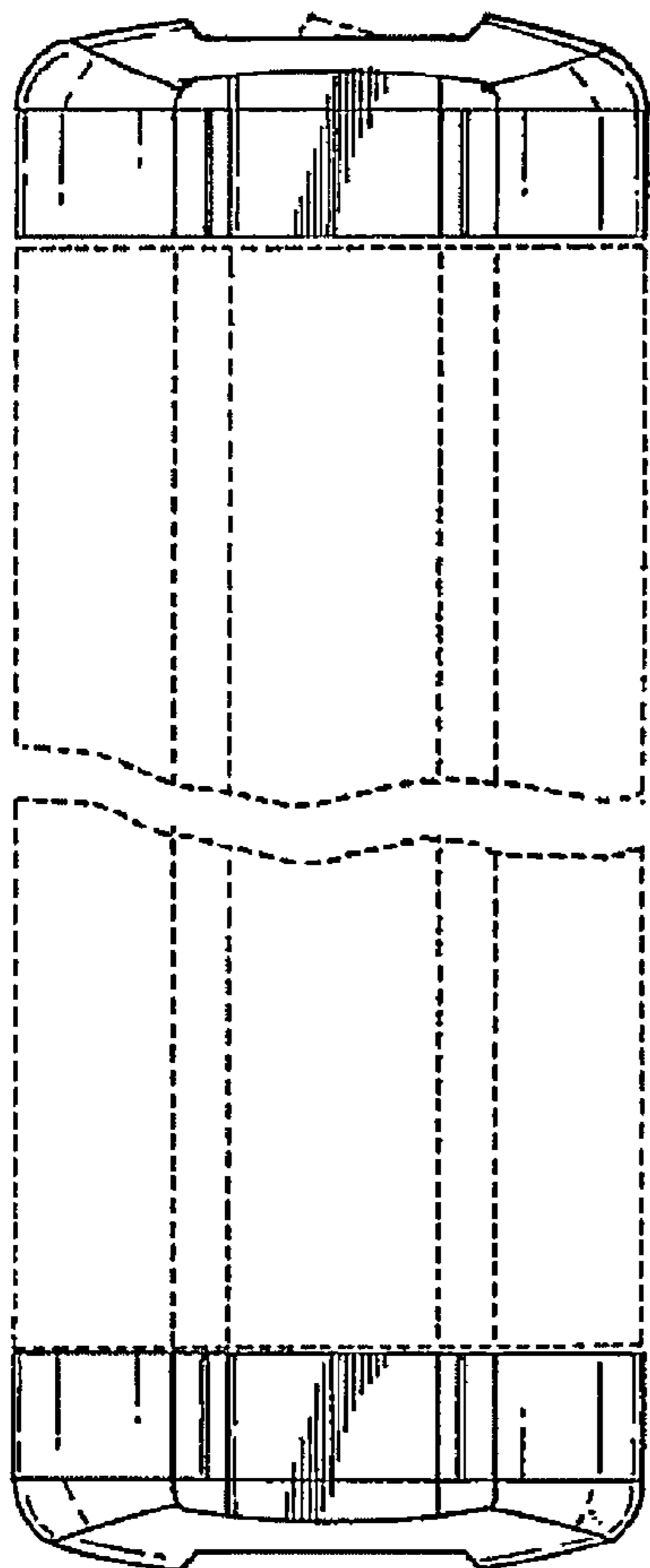
The break lines in the drawings indicate that the appearance of any portion of the lamp between the break lines forms no part of the claimed design.

**1 Claim, 3 Drawing Sheets**

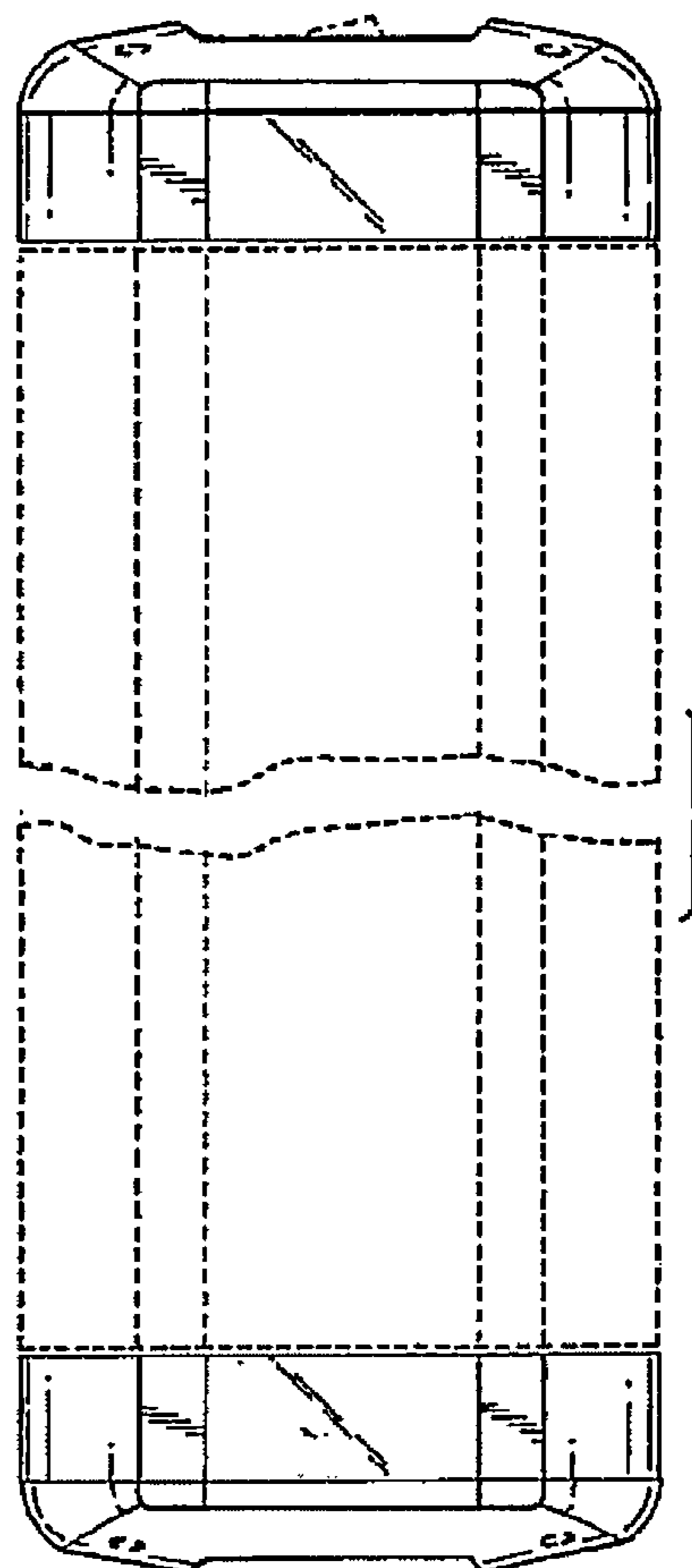




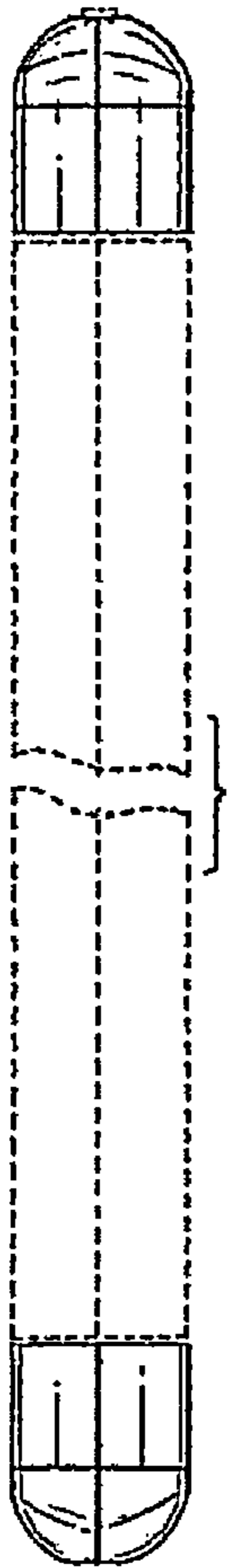
**Fig. 1**



**Fig. 2**



**Fig. 3**



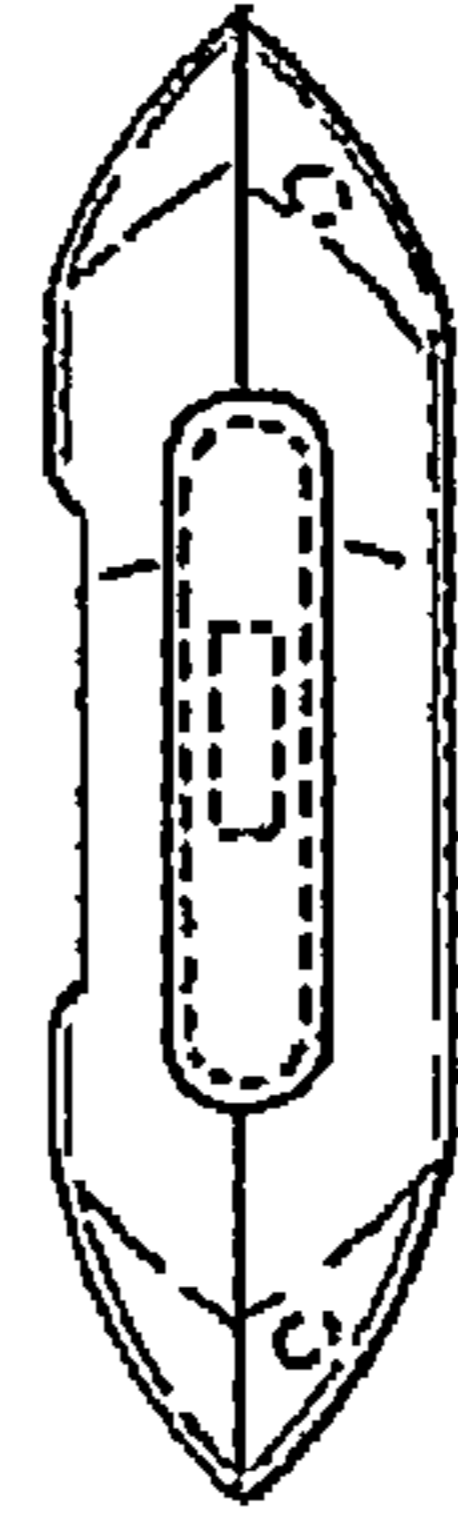
**Fig. 4**



**Fig. 5**



**Fig. 6**



**Fig. 7**