



US00D706390S

(12) **United States Design Patent**
McLauchlan et al.

(10) **Patent No.:** **US D706,390 S**
(45) **Date of Patent:** **** Jun. 3, 2014**

(54) **FUEL TANK ISOLATION VALVE**

(56) **References Cited**

(75) Inventors: **Raymond Bruce McLauchlan**,
Macomb Township, MI (US); **Vaughn**
Kevin Mills, Chelsea, MI (US); **Ronald**
Earl Sexton, South Lyon, MI (US);
Steven Lee Ambrose, Farmington Hills,
MI (US); **Robert Dean Keller**,
Davisburg, MI (US); **Daniel Lee Pifer**,
Chelsea, MI (US)

U.S. PATENT DOCUMENTS

4,227,674	A	*	10/1980	Grant, Jr.	251/15
4,231,542	A	*	11/1980	Grenier	251/15
4,685,156	A	*	8/1987	Brabazon	4/676
4,865,078	A	*	9/1989	Ensign	137/636.1
D314,229	S	*	1/1991	Nestich	D23/233
5,218,995	A	*	6/1993	Lee	137/557
5,996,603	A	*	12/1999	Dupler	137/1
D502,762	S	*	3/2005	Kriegshauser	D23/233
D585,959	S	*	2/2009	Caron et al.	D23/233
D621,003	S	*	8/2010	Gramegna et al.	D23/233
D686,699	S	*	7/2013	Evans et al.	D23/233

(73) Assignee: **Eaton Corporation**, Cleveland, OH
(US)

* cited by examiner

(**) Term: **14 Years**

Primary Examiner — Cynthia Ramirez

(21) Appl. No.: **29/412,051**

(74) *Attorney, Agent, or Firm* — Quinn Law Group, PLLC

(22) Filed: **Jan. 30, 2012**

(57) **CLAIM**

The ornamental design for a fuel tank isolation valve, as shown and described herein.

Related U.S. Application Data

DESCRIPTION

(63) Continuation-in-part of application No. 29/404,911, filed on Oct. 20, 2011, which is a continuation-in-part of application No. 13/011,676, filed on Jan. 21, 2011, now Pat. No. 8,573,255, which is a continuation-in-part of application No. 12/749,924, filed on Mar. 30, 2010, now Pat. No. 8,584,704.

FIG. 1 is a right side view of a fuel tank isolation valve in accordance with the present disclosure.

FIG. 2 is a left side view of the fuel tank isolation valve of FIG. 1.

FIG. 3 is a top view of the fuel tank isolation valve of FIG. 1.

FIG. 4 is a bottom view of the fuel tank isolation valve of FIG. 1.

(51) **LOC (10) Cl.** **23-01**

FIG. 5 is a front view of the fuel tank isolation valve of FIG. 1.

(52) **U.S. Cl.**
USPC **D23/233**

FIG. 6 is a rear view of the fuel tank isolation valve of FIG. 1.

(58) **Field of Classification Search**
USPC D23/233–237, 244–249; 192/87.13,
192/3.57, 87.18; 251/129.01, 137, 282,
251/324–325, 321, 355, 129.08, 129.07;
137/398, 545, 547, 549, 556.3, 553,
137/556.6, 625.65, 625.25

FIG. 7 is a top right rear perspective view of the fuel tank isolation valve of FIG. 1; and,

FIG. 8 is a bottom left front perspective view of the fuel tank isolation valve of FIG. 1.

The broken lines showing portions of the fuel tank isolation valve form no part of the claimed design.

See application file for complete search history.

1 Claim, 6 Drawing Sheets

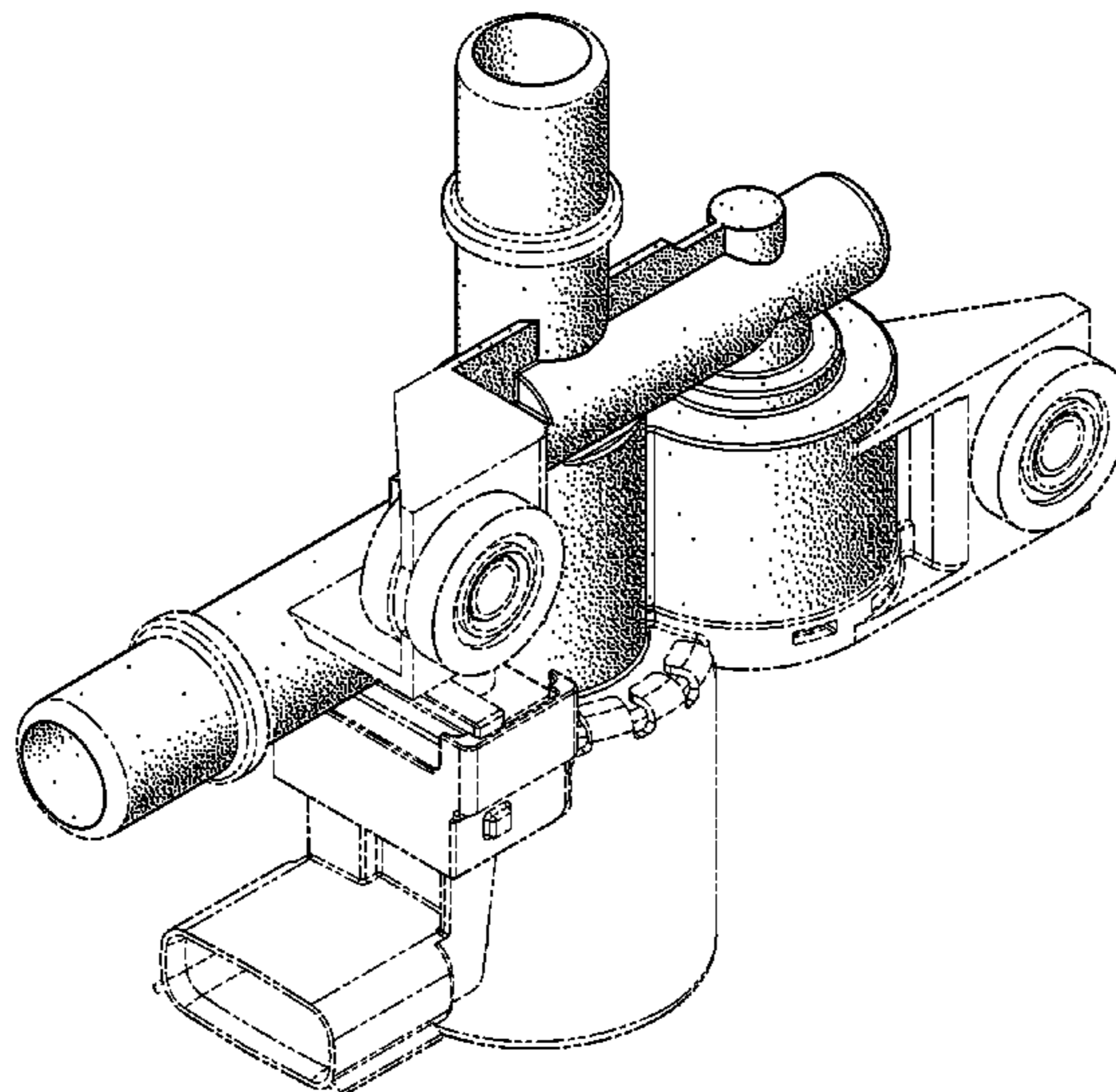

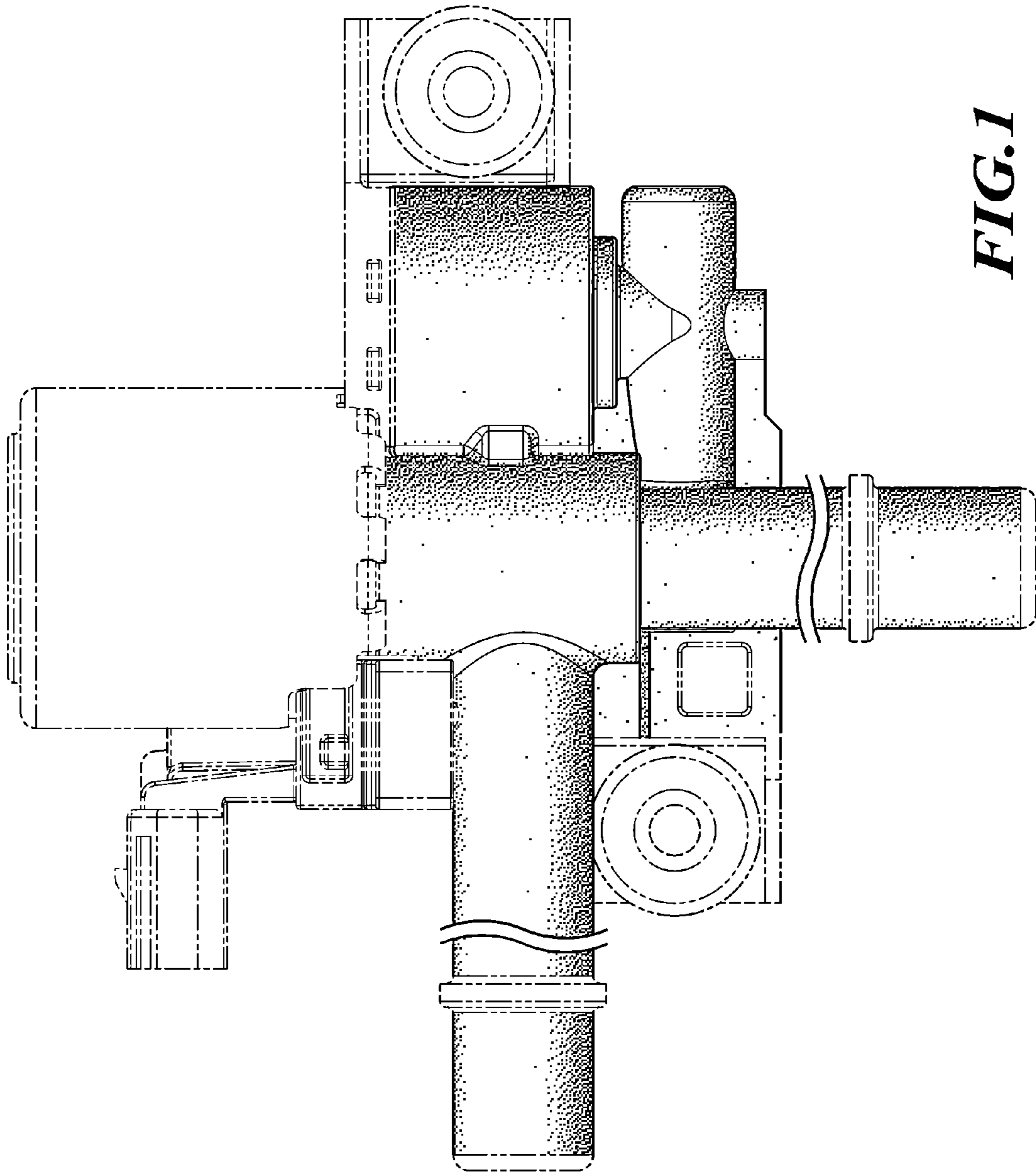

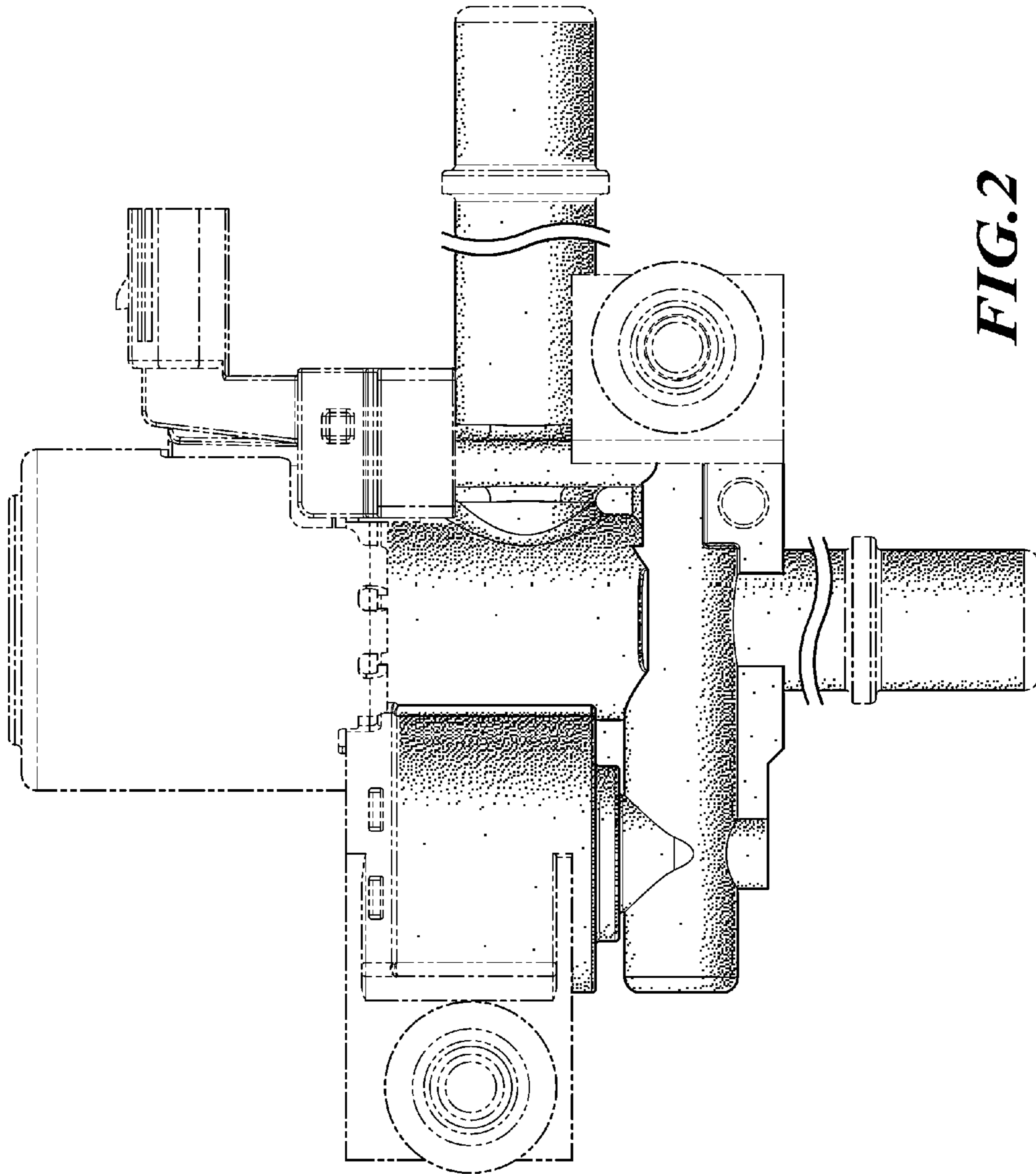

FIG. 2

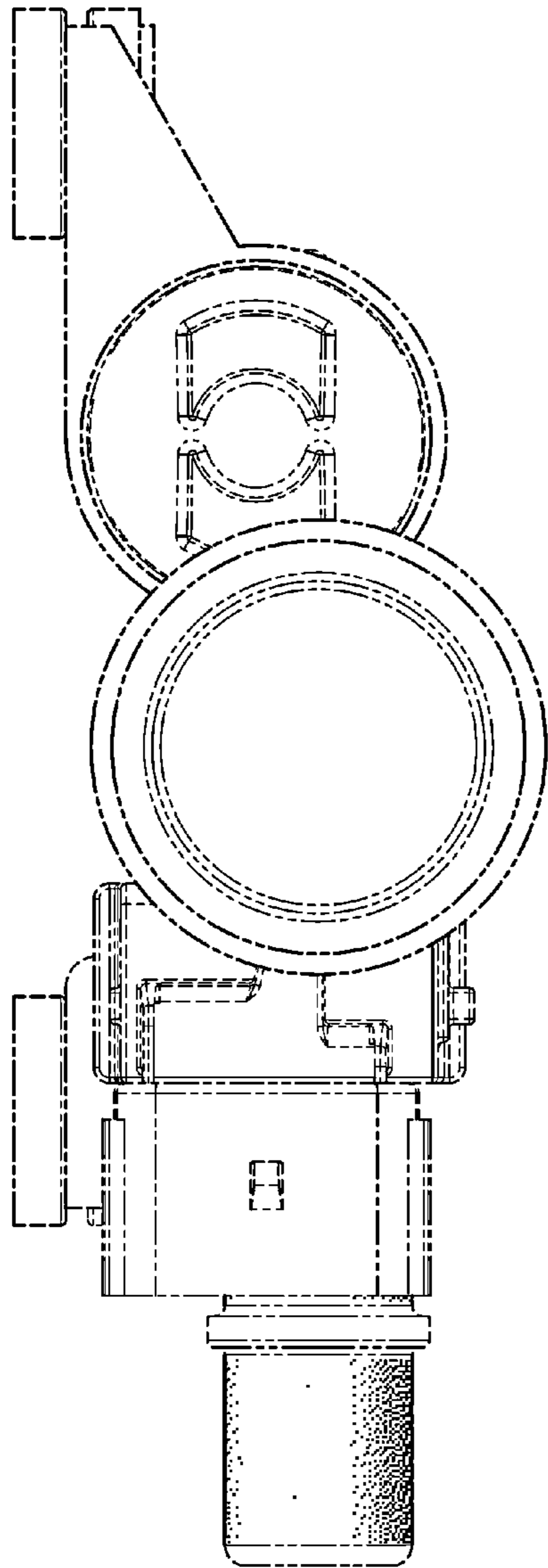

FIG. 3

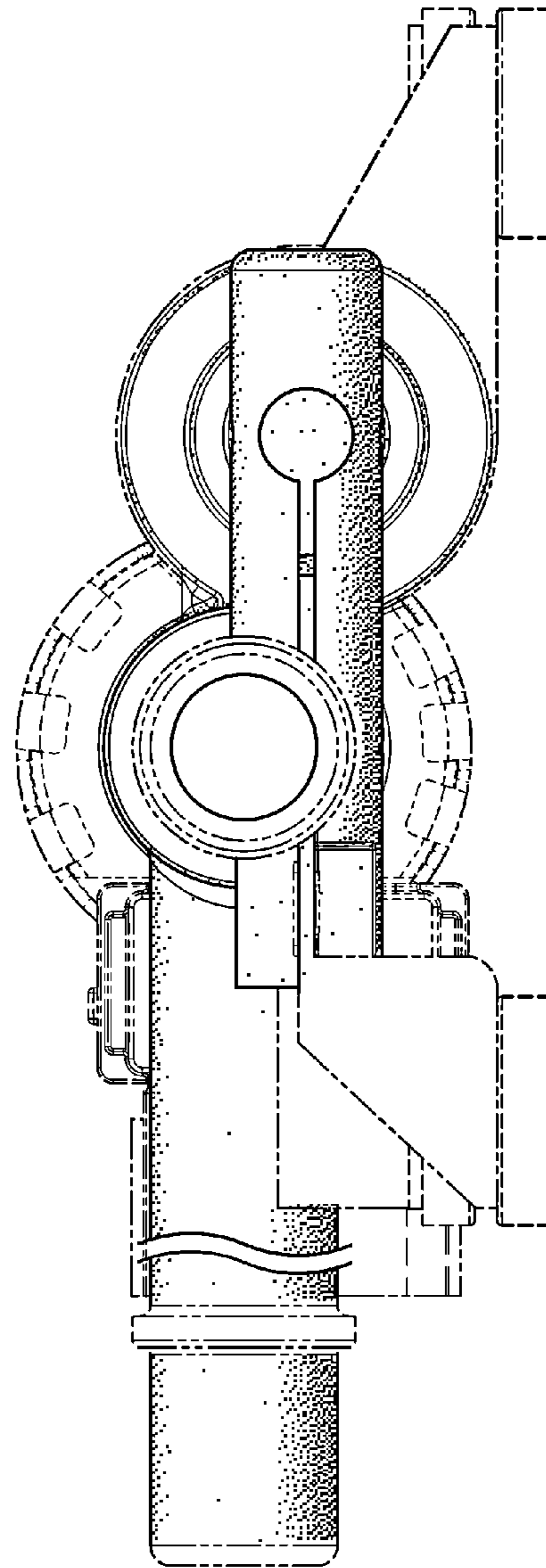

FIG. 4

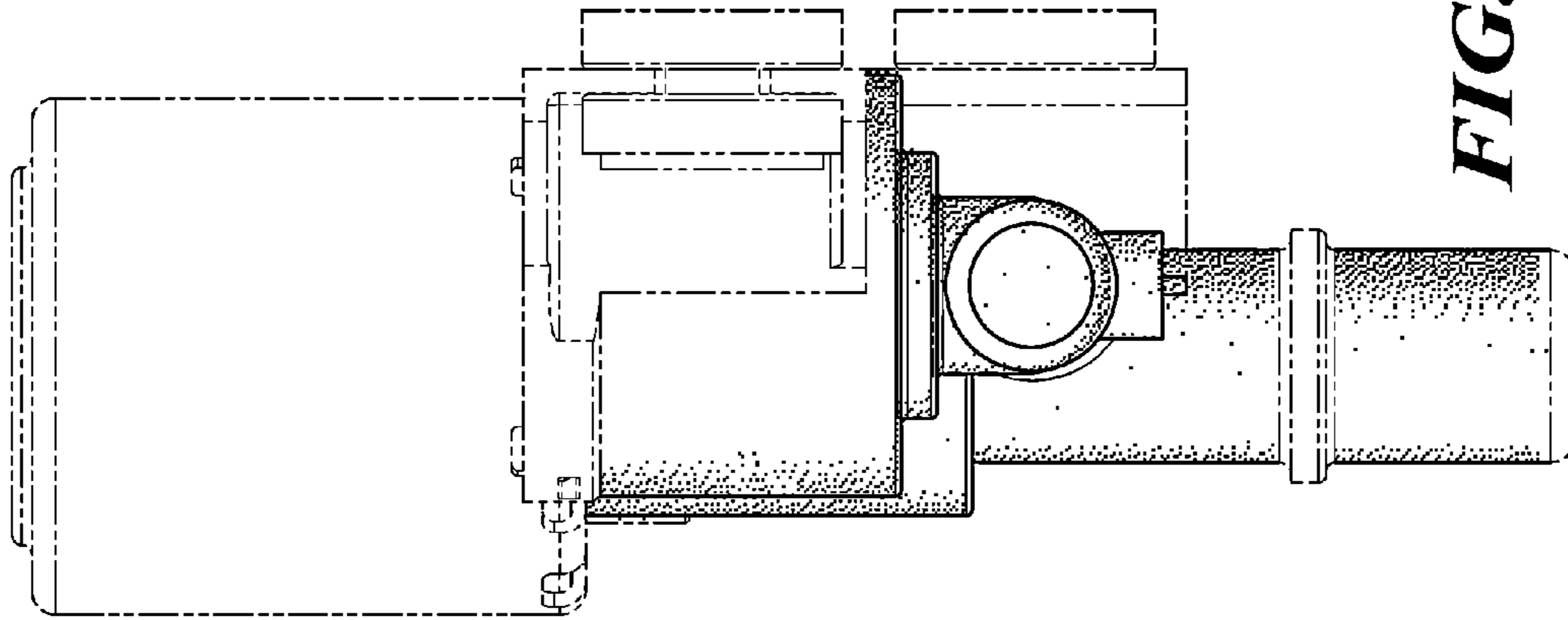

FIG. 6

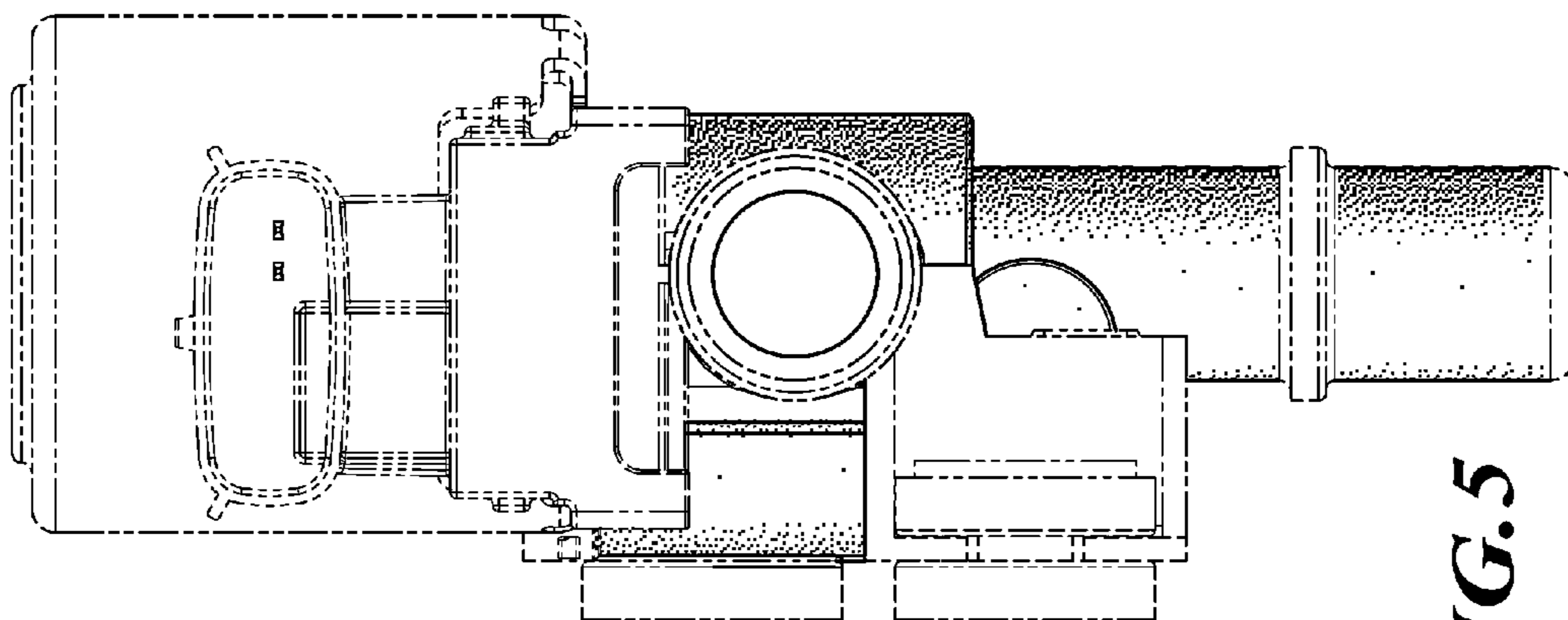

FIG. 5

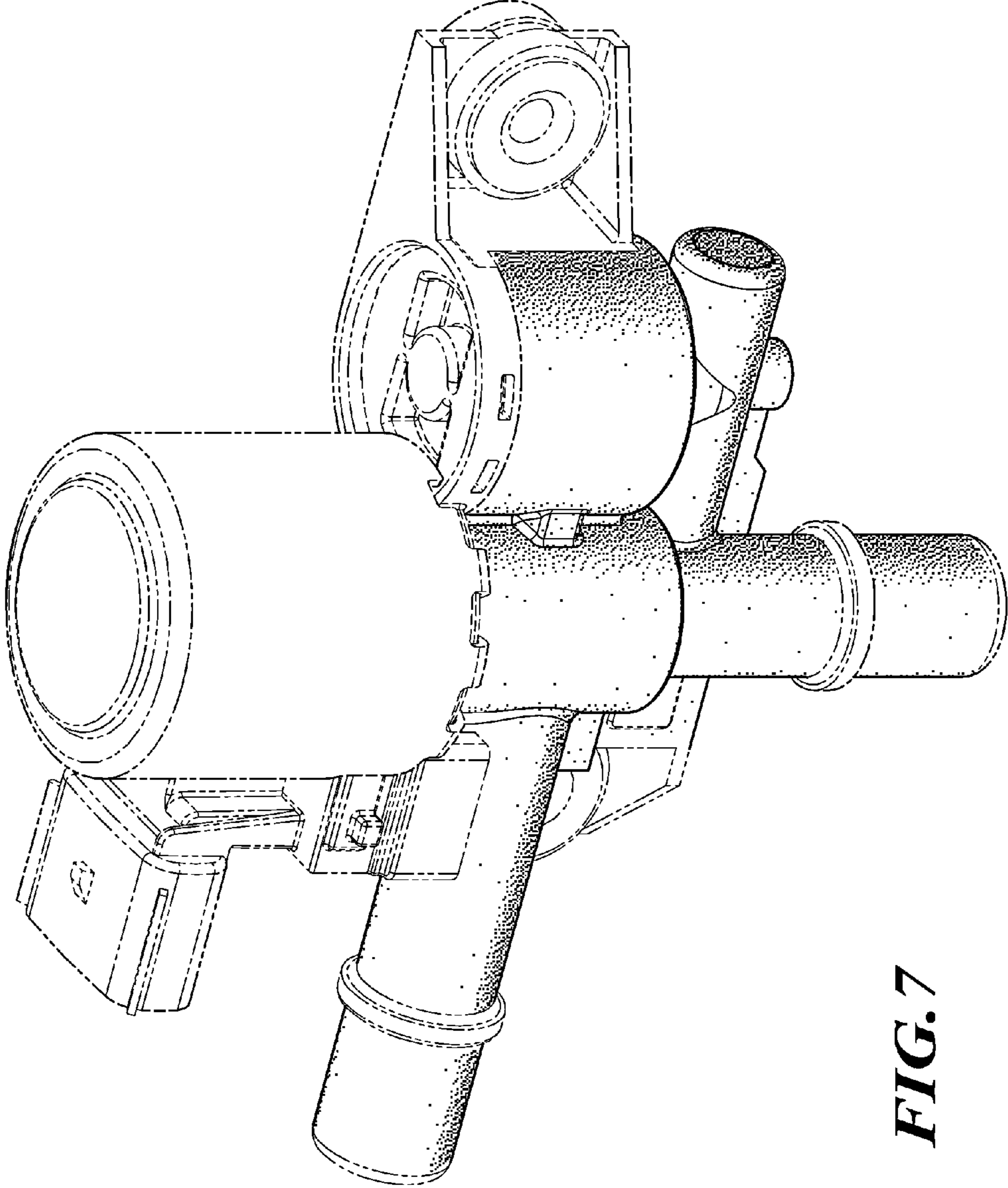

FIG. 7

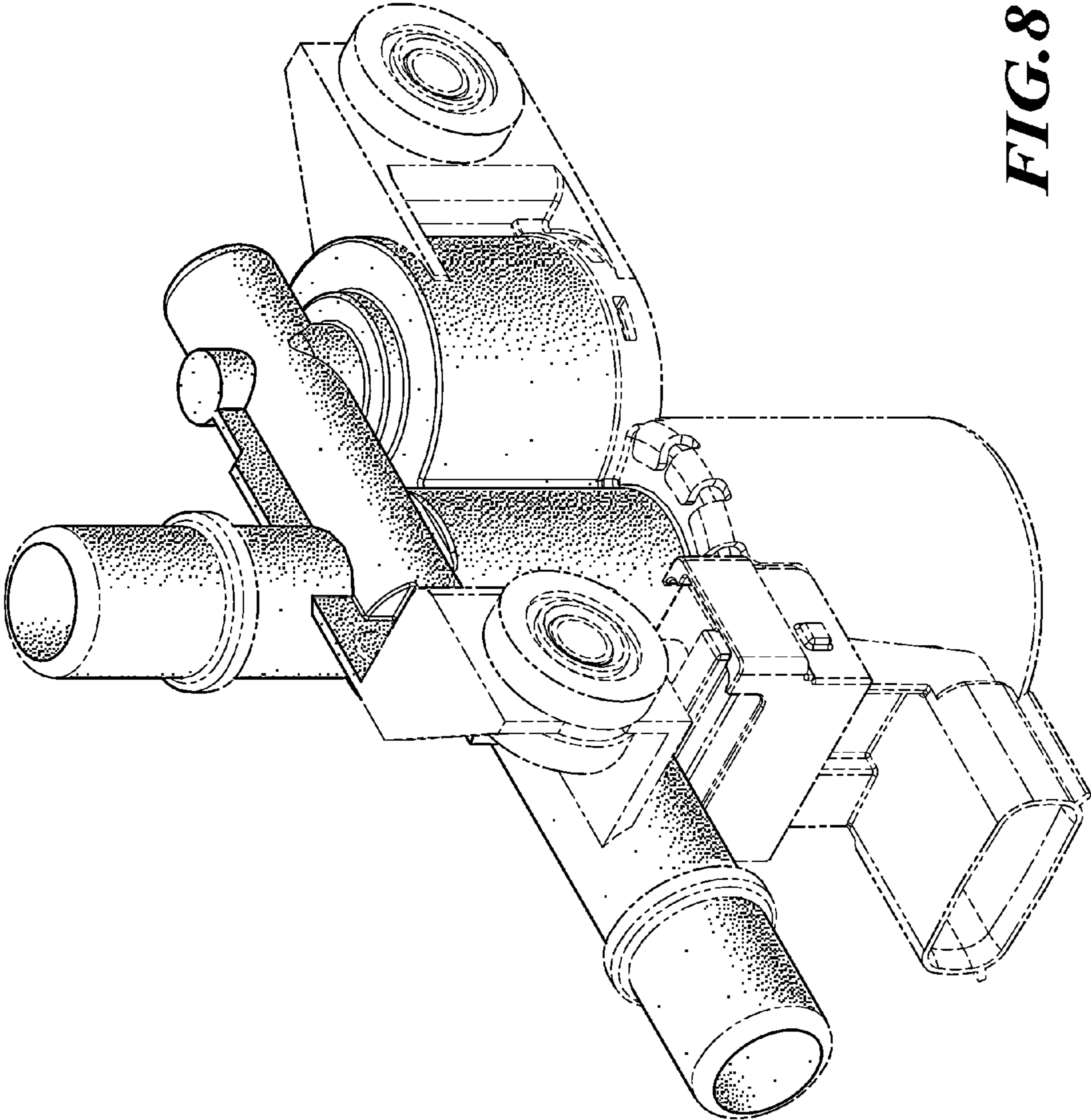

FIG. 8