



US00D706210S

(12) **United States Design Patent**
Broughton

(10) **Patent No.:** **US D706,210 S**
(45) **Date of Patent:** **** Jun. 3, 2014**

- (54) **SEAT BELT CUSHION**
- (76) Inventor: **Marcela Broughton**, N. Miami, FL (US)
- (**) Term: **14 Years**
- (21) Appl. No.: **29/386,956**
- (22) Filed: **Mar. 7, 2011**
- (51) **LOC (10) Cl.** **12-16**
- (52) **U.S. Cl.**
USPC **D12/422**
- (58) **Field of Classification Search**
USPC D12/407, 415-16, 422-424; D3/276,
D3/273-274, 284, 289, 301-305, 299,
D3/216; 224/542-543, 402-406, 563, 311,
224/313, 901.8, 925, 497, 545, 223, 920;
296/37.1-37.8, 37.16; 114/361, 343;
211/201, 12; 206/315.11; 297/228.1
See application file for complete search history.

D404,767 S *	1/1999	Joun	D19/86
D504,767 S *	5/2005	DiMarchi et al.	D3/215
D543,032 S *	5/2007	Owenby	D3/303
D596,172 S *	7/2009	Ahlqvist	D14/251
D651,800 S *	1/2012	Scott	D3/303
D652,215 S *	1/2012	Baas et al.	D3/303
D655,702 S *	3/2012	Saxton	D14/253
D656,071 S *	3/2012	Treon	D12/133

* cited by examiner

Primary Examiner — Katrina A Betton
(74) *Attorney, Agent, or Firm* — Christopher J. Vandam, PA;
Chris Vandam

(57) **CLAIM**
I claim the ornamental design for a seat belt cushion, as shown and described.

DESCRIPTION

FIG. 1 shows a perspective view of the front side of the seat belt cushion. The rear of the seatbelt cushion in broken lines is not claimed.
FIG. 2 shows a perspective view thereof also showing in broken lines non-elements consisting of a seat belt, pen, gum and phone. The rear of the seatbelt cushion in broken lines is not claimed; and,
FIG. 3 shows a perspective view thereof unfolded as the device might be configured for storage.

1 Claim, 2 Drawing Sheets

- (56) **References Cited**
U.S. PATENT DOCUMENTS
D311,919 S * 11/1990 Klaczak et al. D14/256
D313,694 S * 1/1991 Mawhinney et al. D12/422
D318,641 S * 7/1991 Schwartz D12/422
D384,030 S * 9/1997 Lazzeroni et al. D12/422
D388,611 S * 1/1998 Shaw D3/303

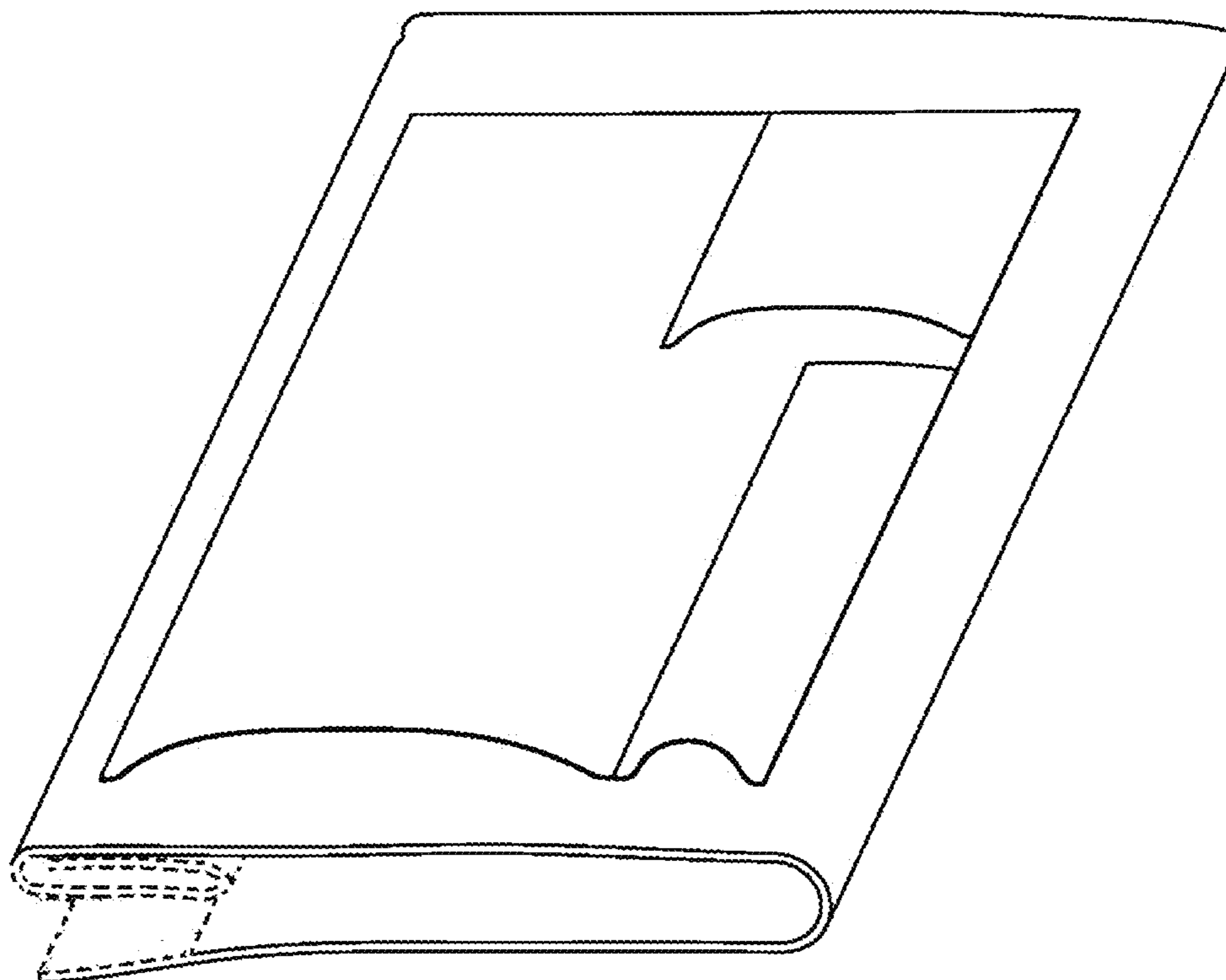

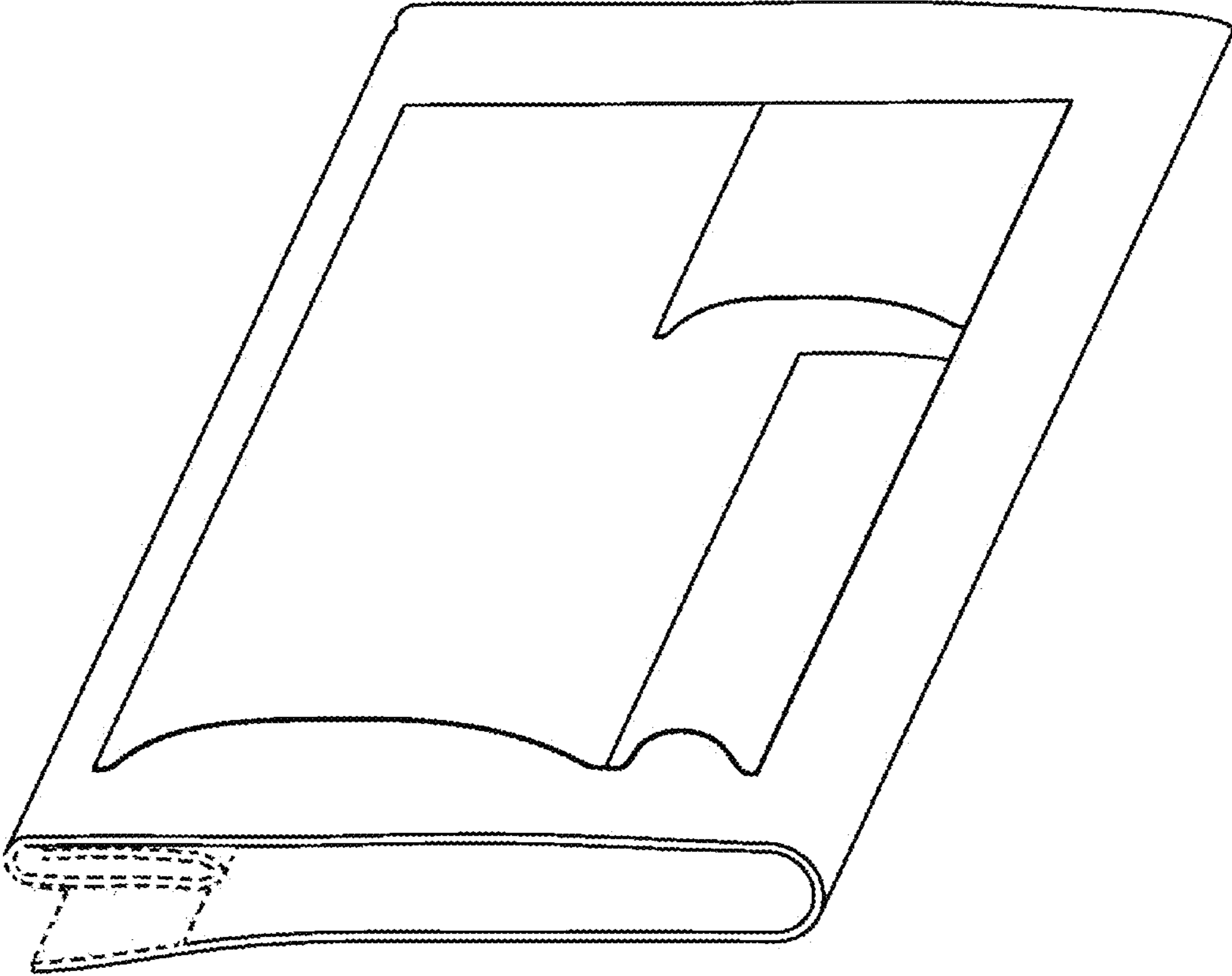

Fig. 1

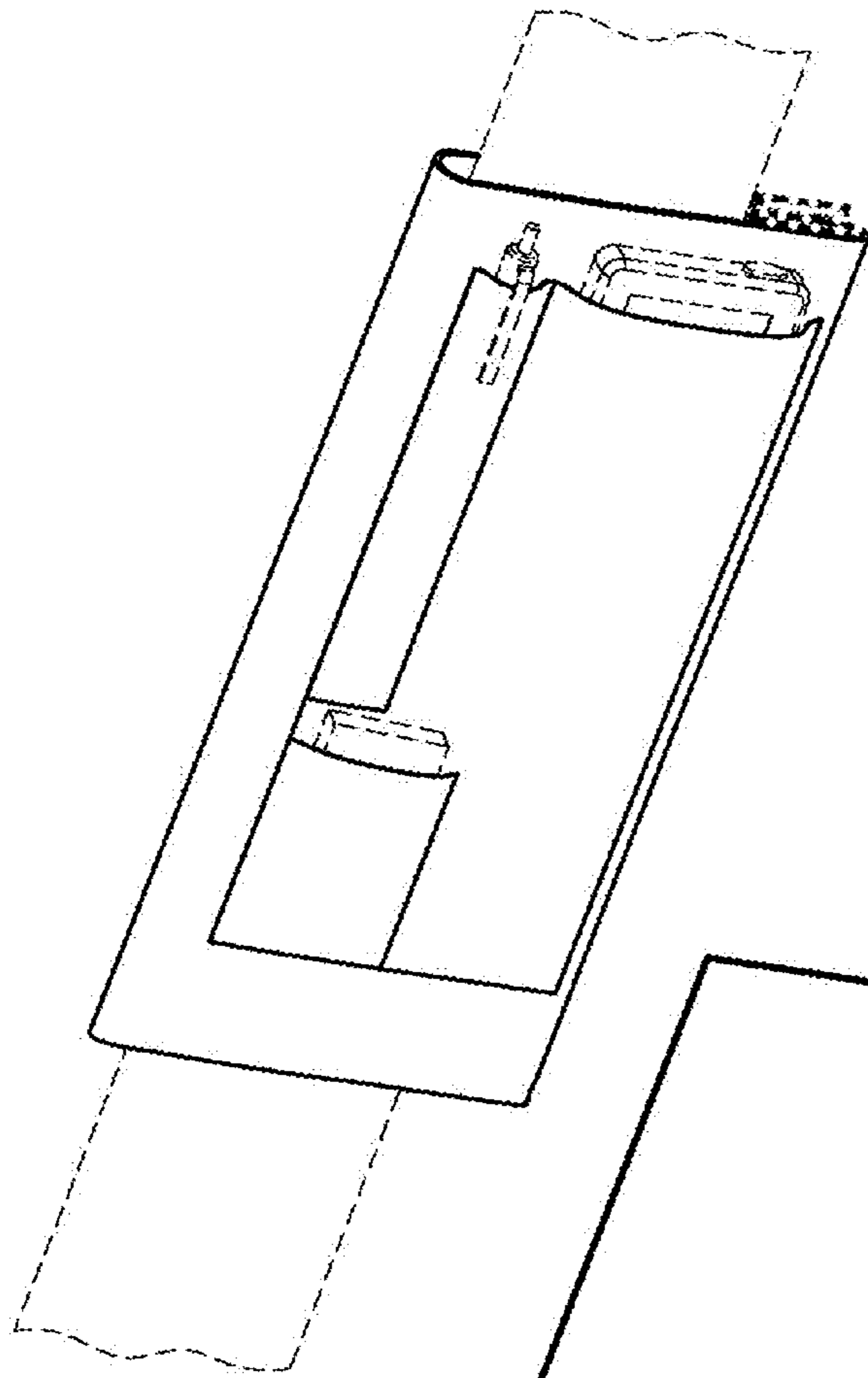

Fig. 2

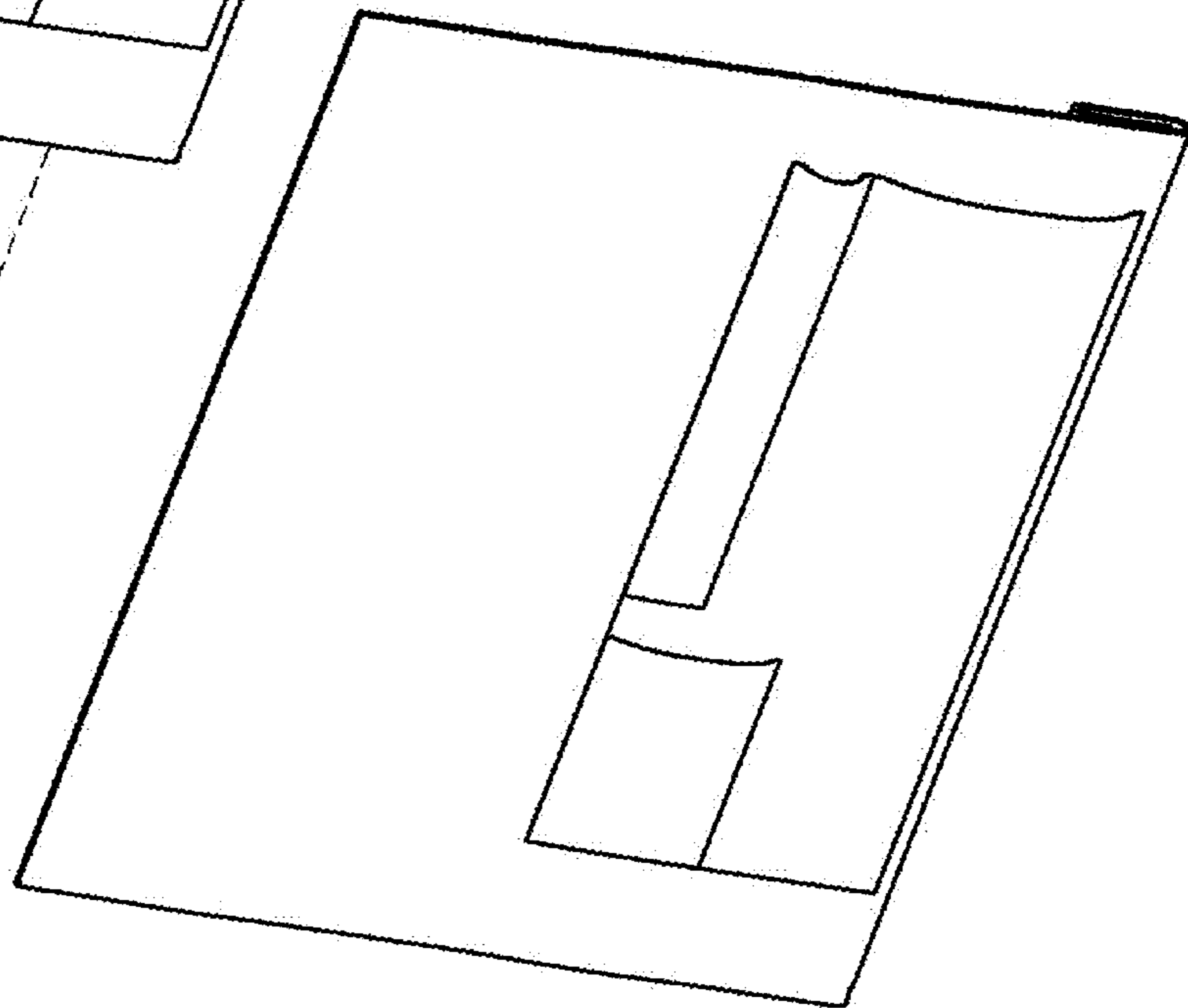

Fig. 3