



US00D706178S

(12) **United States Design Patent**
Shirk, Jr.

(10) **Patent No.:** **US D706,178 S**
(45) **Date of Patent:** **** Jun. 3, 2014**

- (54) **SAFETY CATCH**
- (71) Applicant: **Paul W. Shirk, Jr.**, Goshen, IN (US)
- (72) Inventor: **Paul W. Shirk, Jr.**, Goshen, IN (US)
- (73) Assignee: **Integrity Innovations Group, LLC**
- (**) Term: **14 Years**
- (21) Appl. No.: **29/439,299**
- (22) Filed: **Dec. 10, 2012**
- (51) **LOC (10) Cl.** **12-16**
- (52) **U.S. Cl.**
USPC **D12/162**
- (58) **Field of Classification Search**
USPC D12/159, 160, 161, 162; D8/330-331,
D8/339, 342, 344; 280/433-437, 438.1,
280/439-441; 16/49, 71, 82
See application file for complete search history.

2,826,429	A *	3/1958	Holland	280/429
5,876,055	A *	3/1999	Fontaine	280/437
6,491,317	B1 *	12/2002	Breese et al.	280/432

* cited by examiner

Primary Examiner — Michael A Pratt
(74) *Attorney, Agent, or Firm* — Botkin & Hall, LLP

(57) **CLAIM**
The ornamental design for a safety catch, as shown and described.

DESCRIPTION

FIG. 1 is a perspective view of the safety catch showing a top side;
FIG. 2 is a top view of the safety catch shown in FIG. 1;
FIG. 3 is a side view of the safety catch shown in FIG. 1;
FIG. 4 is a rear view of safety catch shown in FIG. 1;
FIG. 5 is a front view safety catch shown in FIG. 1; and,
FIG. 6 is a bottom view of the safety catch shown in FIG. 1.
The broken line showing of aspects of safety catch shown in FIGS. 1 through 7 is included for the purpose of illustrating aspects of the claimed design that forms no part of the claimed design. The broken lines showing in FIG. 7 is included for the purpose of illustrating environment and does not form a part of the claimed design.

- (56) **References Cited**
U.S. PATENT DOCUMENTS
1,968,623 A * 7/1934 Swift 280/437
2,194,005 A * 3/1940 Campbell 292/33

1 Claim, 3 Drawing Sheets

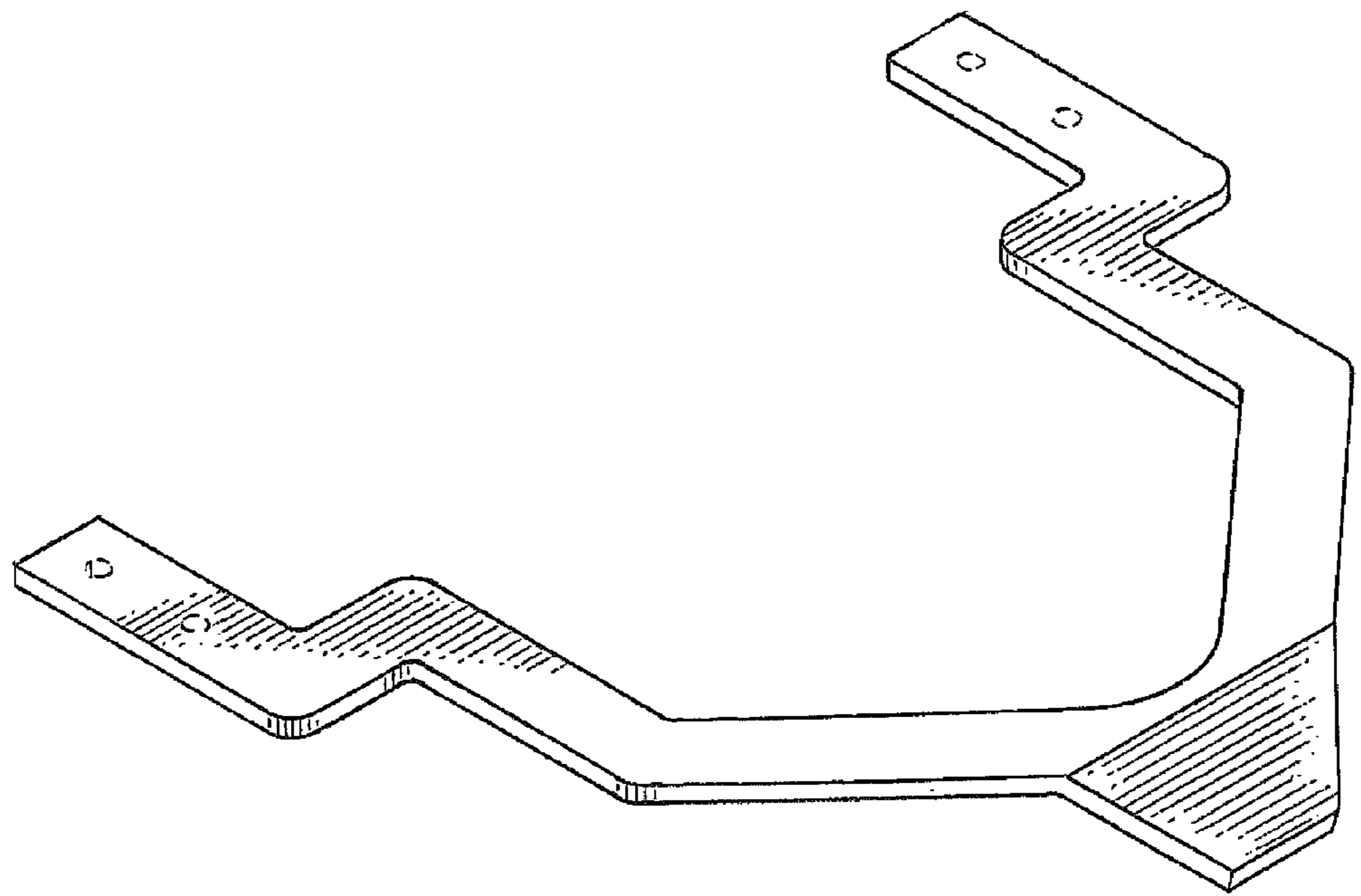

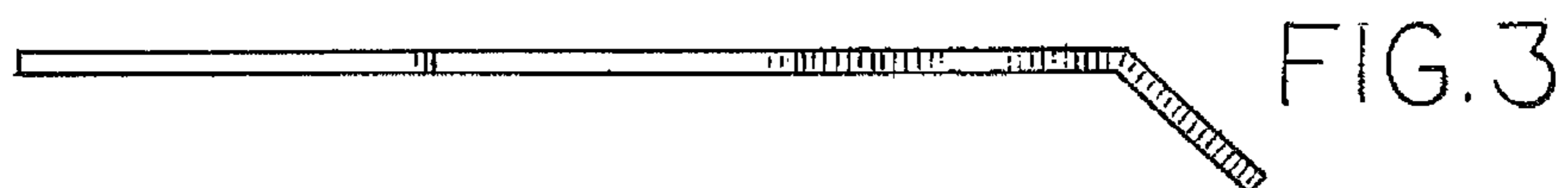
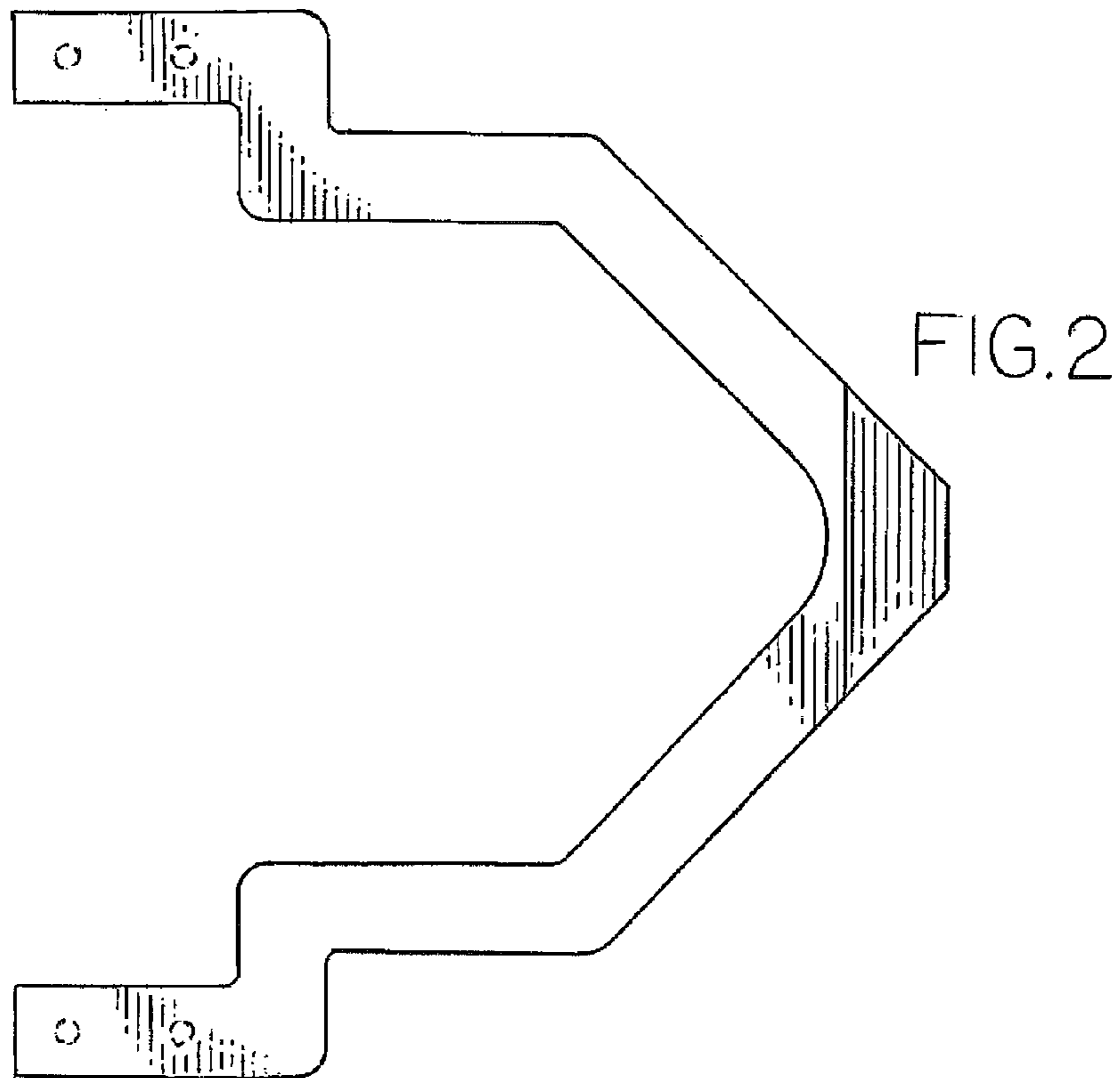
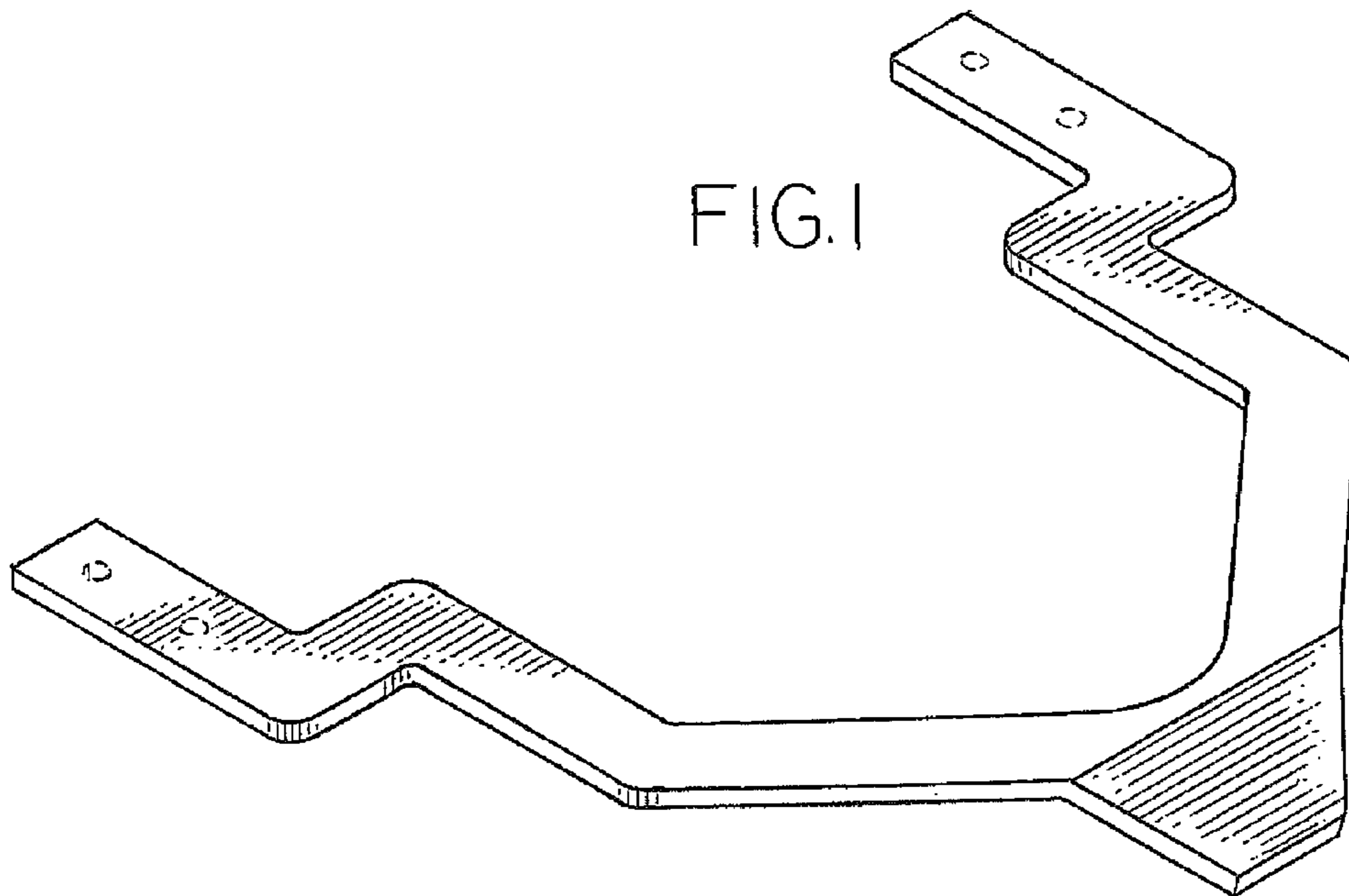

FIG.4

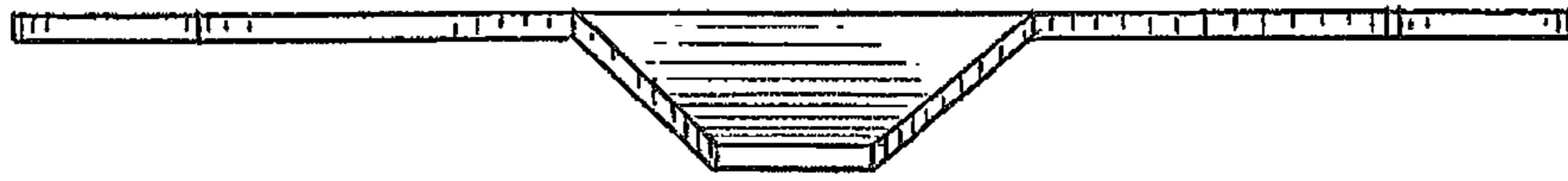

FIG.5

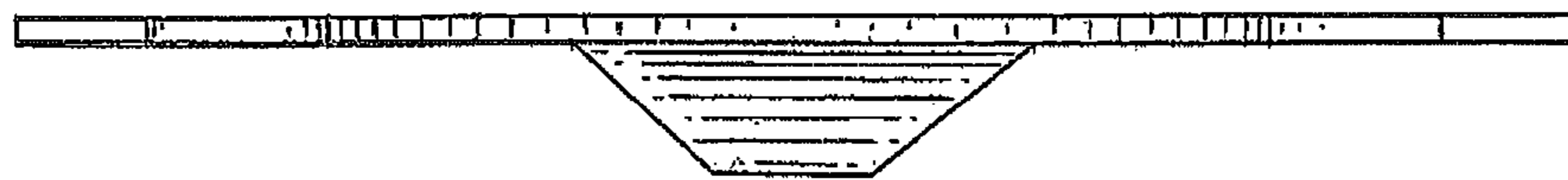

FIG.6

