



US00D705841S

(12) **United States Design Patent**
Hasuda

(10) **Patent No.:** **US D705,841 S**

(45) **Date of Patent:** **** May 27, 2014**

(54) **INTERMEDIATE ADAPTER FOR A CAMERA**

(56)

References Cited

(71) Applicant: **Nikon Corporation**, Tokyo (JP)

(72) Inventor: **Masanori Hasuda**, Fujisawa (JP)

(73) Assignee: **Nikon Corporation**, Tokyo (JP)

(**) Term: **14 Years**

(21) Appl. No.: **29/451,766**

(22) Filed: **Apr. 8, 2013**

U.S. PATENT DOCUMENTS

4,063,264	A	*	12/1977	Ando et al.	396/531
4,118,713	A		10/1978	Murakami et al.	
D251,669	S	*	4/1979	Ueda et al.	D16/134
5,262,899	A	*	11/1993	Iizuka	359/811
5,481,406	A	*	1/1996	Yamazaki et al.	359/694
5,570,153	A	*	10/1996	Shono	396/531
D375,969	S	*	11/1996	Watanabe	D16/134
D390,857	S	*	2/1998	Hayamizu	D16/134

(Continued)

OTHER PUBLICATIONS

The Restriction Requirement in U.S. Appl. No. 29/451,771, dated Dec. 2, 2013, pp. 1-8.

Primary Examiner — Phillip S Hyder

(74) *Attorney, Agent, or Firm* — Wolf, Greenfield & Sacks, P.C.; Randy J. Pritzker

Related U.S. Application Data

(62) Division of application No. 29/412,567, filed on Feb. 6, 2012.

Foreign Application Priority Data

Aug. 10, 2011	(JP)	2011-018386
Sep. 15, 2011	(JP)	2011-021121
Sep. 15, 2011	(JP)	2011-021122
Sep. 15, 2011	(JP)	2011-021123
Sep. 15, 2011	(JP)	2011-021124
Sep. 15, 2011	(JP)	2011-021125
Sep. 15, 2011	(JP)	2011-021126
Sep. 15, 2011	(JP)	2011-021127

(51) **LOC (10) Cl.** **16-06**

(52) **U.S. Cl.**
USPC **D16/134**

(58) **Field of Classification Search**
USPC D16/130, 134, 136, 200, 202, 204, 218,
D16/219; 359/642, 811, 819, 827, 828, 830;
396/529, 530, 531, 532; 348/373, 374,
348/375, 376; 358/909.1

See application file for complete search history.

(57) **CLAIM**

The ornamental design for an intermediate adapter for a camera, as shown and described.

DESCRIPTION

FIG. 1 is a perspective view of an embodiment of an intermediate adapter for a camera showing my new design; FIG. 2 is a rear elevational view thereof; FIG. 3 is a top plan view thereof; FIG. 4 is a bottom plan view thereof, rotated 180 degrees relative to FIG. 3; FIG. 5 is a right side elevational view thereof; and, FIG. 6 is a left side elevational view thereof. The features shown in broken lines in the drawings depict environmental subject matter only and form no part of the claimed design. The dot-dashed lines denote the boundary of the claim and form no part of the claimed design.

1 Claim, 6 Drawing Sheets

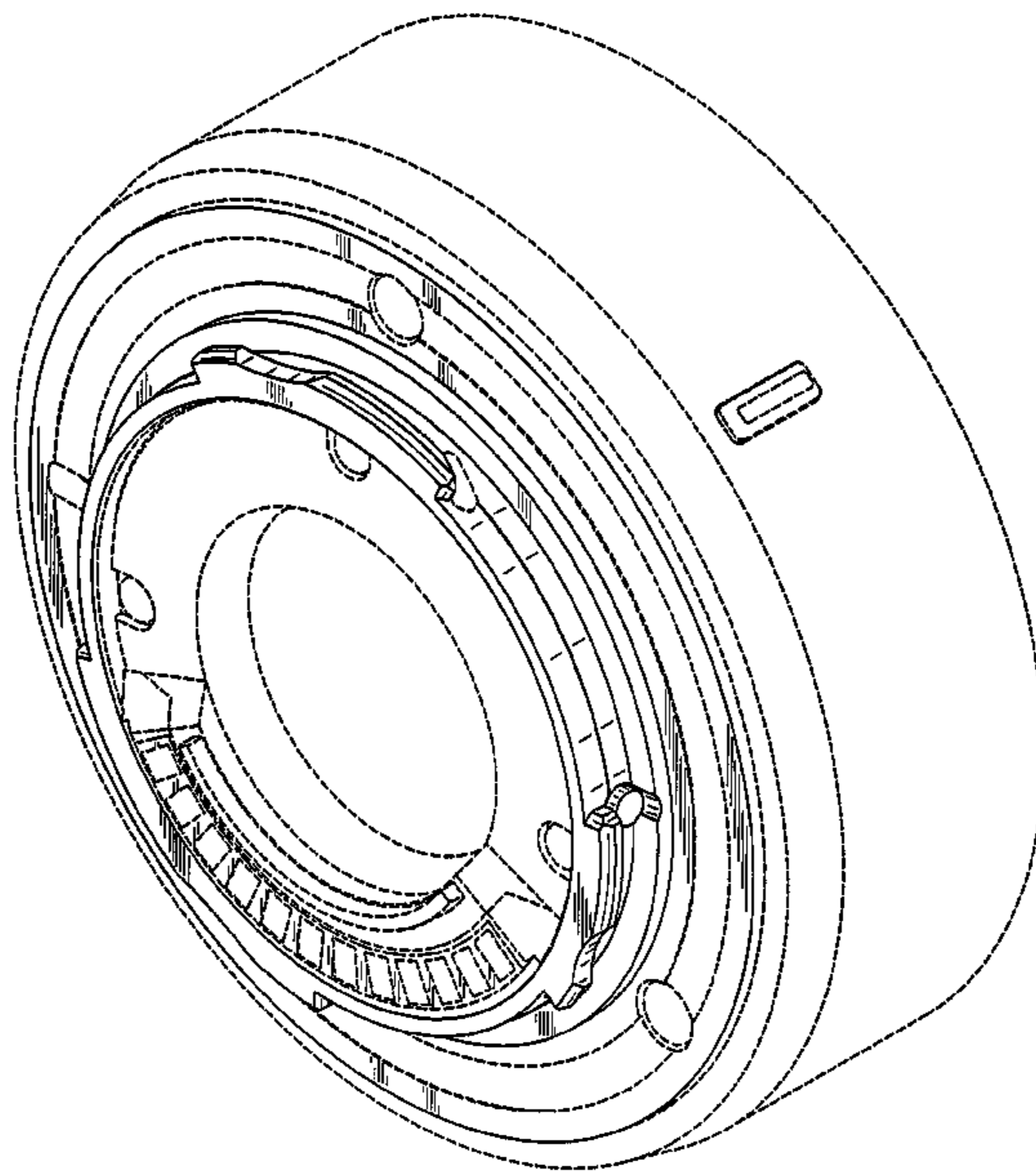

(56)

References Cited

U.S. PATENT DOCUMENTS

D420,029 S *	2/2000	Kimura et al.	D16/134	D559,884 S *	1/2008	Tokiwa	D16/219
D425,088 S *	5/2000	Watanabe	D16/134	7,593,169 B2 *	9/2009	Ouchi	359/702
D433,044 S *	10/2000	Nagaoka et al.	D16/134	7,625,144 B2 *	12/2009	Kranz et al.	396/529
D441,382 S *	5/2001	Konno et al.	D16/134	7,798,137 B2 *	9/2010	Ewing	124/86
6,369,960 B2 *	4/2002	Azegami	359/819	7,798,731 B2	9/2010	Kurosawa	
6,554,503 B2 *	4/2003	Imanari et al.	396/531	7,848,634 B2 *	12/2010	Kranz et al.	396/310
D482,377 S *	11/2003	Tajima	D16/134	7,853,137 B2 *	12/2010	Yang	396/71
D523,057 S *	6/2006	Watanabe	D16/219	7,961,411 B2 *	6/2011	Lee	359/819
D537,096 S *	2/2007	Tokiwa et al.	D16/219	7,988,372 B2 *	8/2011	Lee et al.	396/531
D537,461 S	2/2007	Tokiwa et al.		8,002,483 B2 *	8/2011	Fujiwara et al.	396/531
D539,320 S *	3/2007	Tokiwa et al.	D16/219	8,027,576 B2 *	9/2011	Lai	396/25
D540,363 S *	4/2007	Tokiwa et al.	D16/219	D665,837 S	8/2012	Tainaka	
D549,263 S	8/2007	Tokiwa et al.		D670,751 S	11/2012	Koyama et al.	
D549,264 S *	8/2007	Tokiwa	D16/219	D671,586 S	11/2012	Asano et al.	
D552,147 S *	10/2007	Tajima	D16/219	2010/0226023 A1	9/2010	Lee	
				2011/0274424 A1	11/2011	Fujiwara et al.	
				2012/0039595 A1	2/2012	Youn	

* cited by examiner

FIG. 1

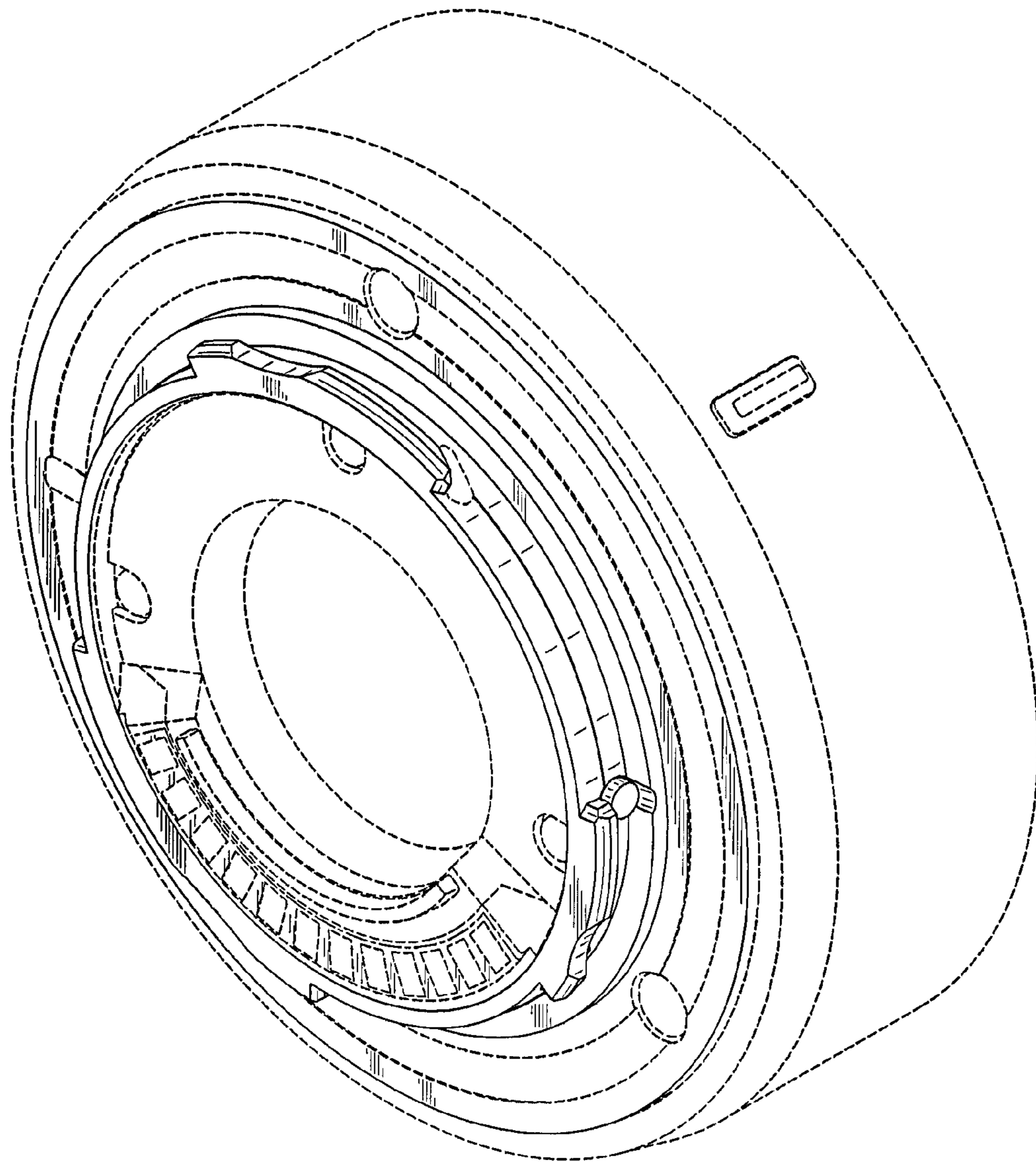

FIG. 2

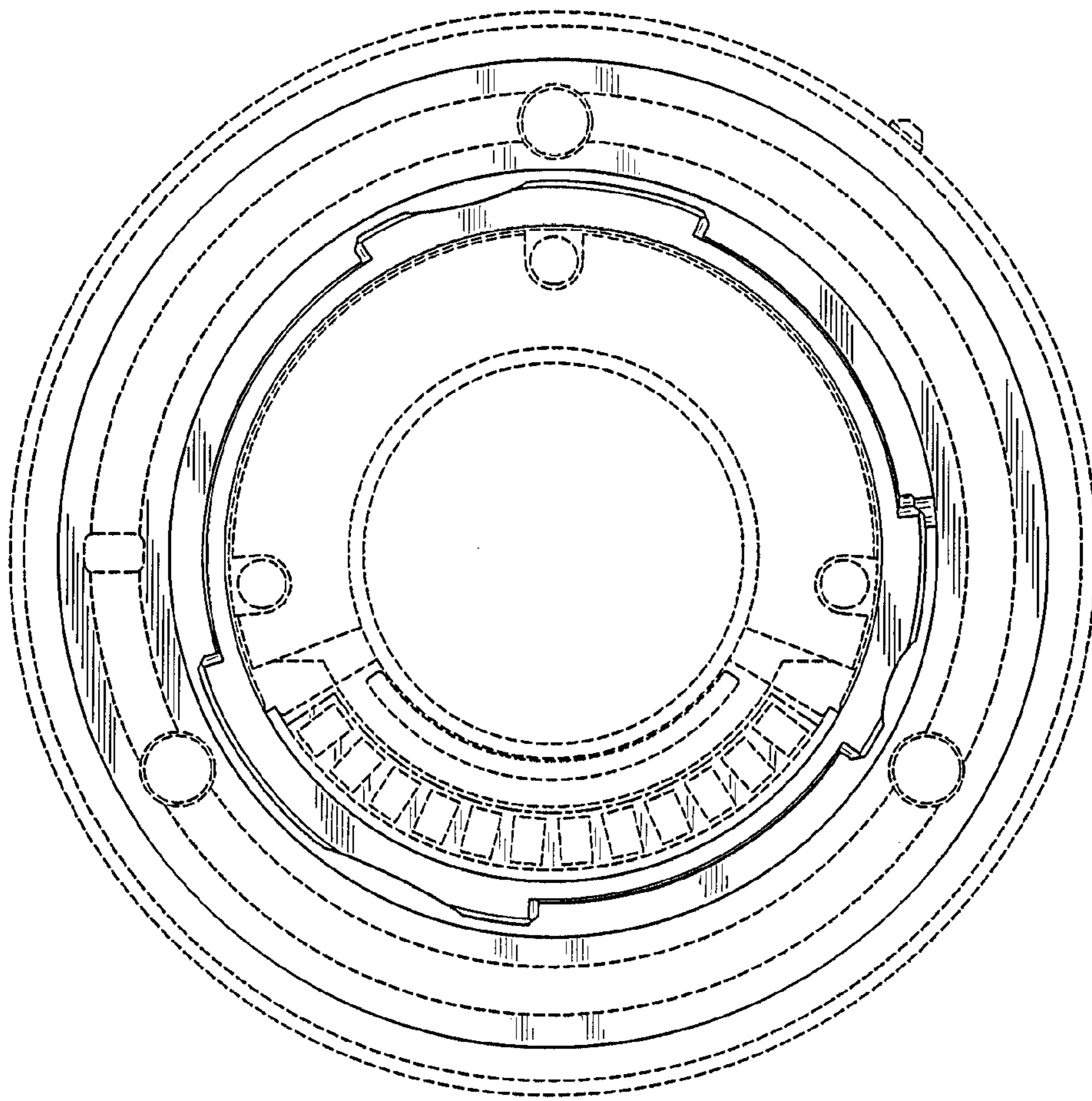

FIG. 3

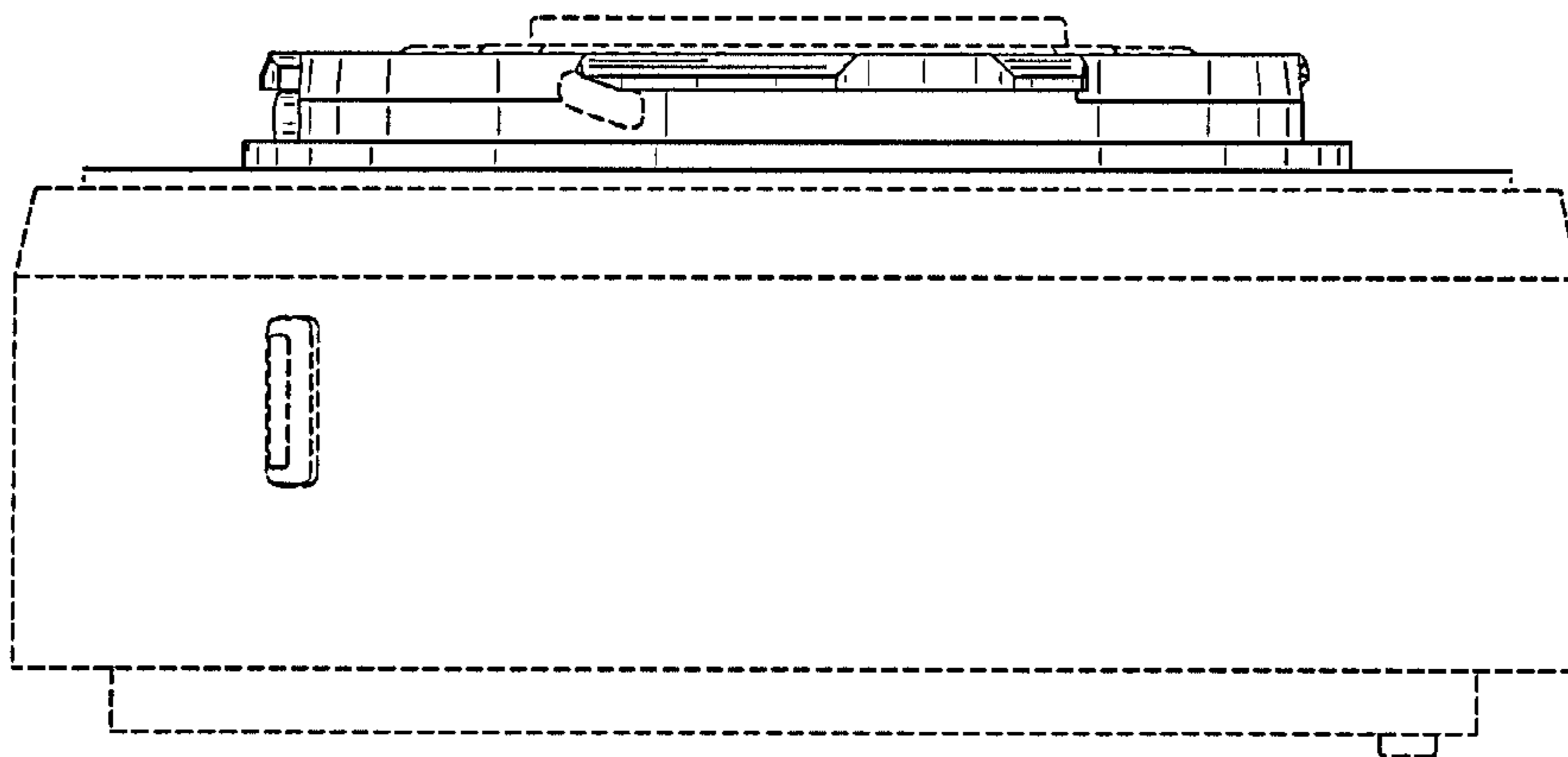

FIG. 4

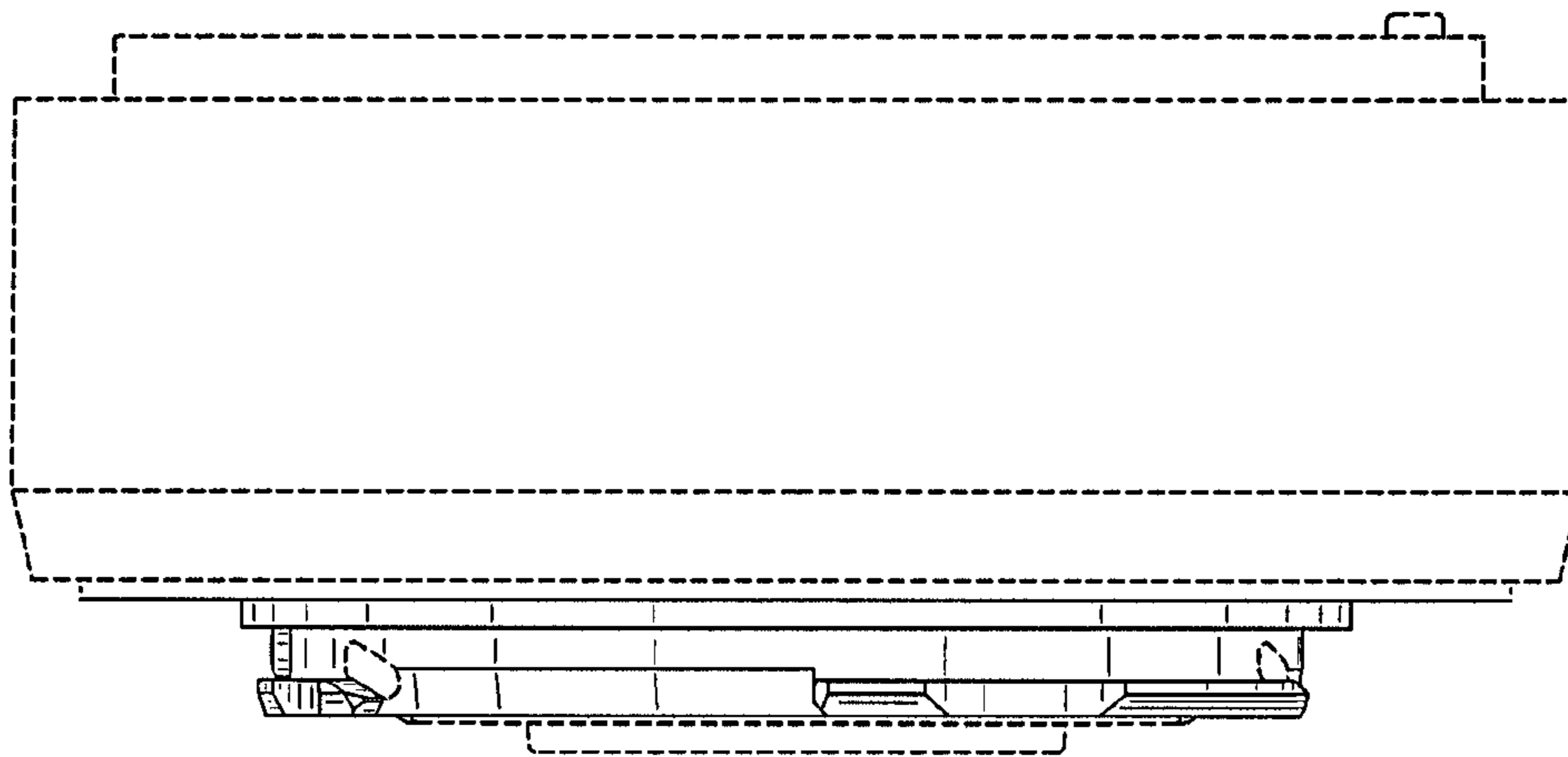

FIG. 5

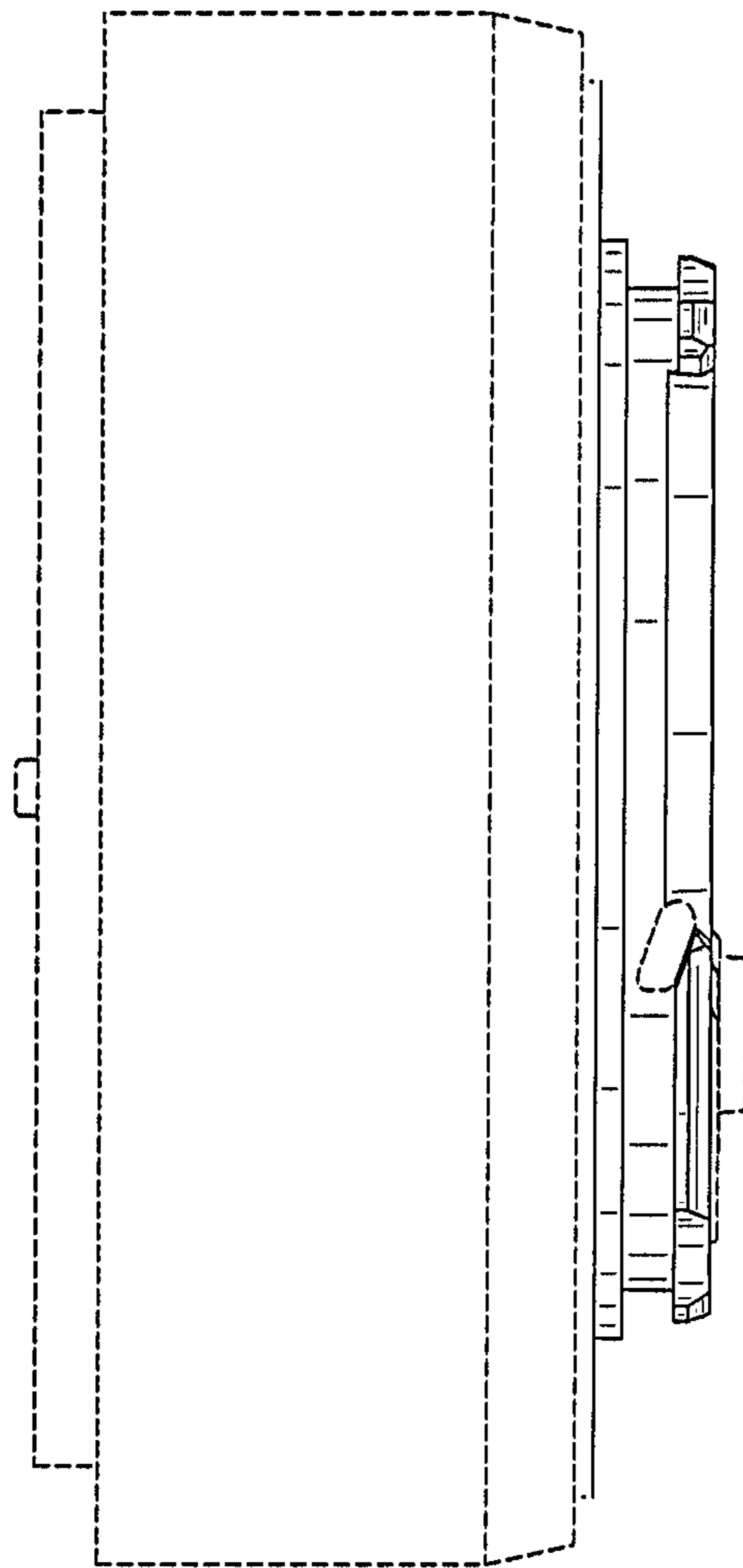

FIG. 6

