



US00D705825S

(12) **United States Design Patent**  
**Lafond et al.**

(10) **Patent No.:** **US D705,825 S**

(45) **Date of Patent:** **\*\* May 27, 2014**

(54) **ICE MACHINE INTERFACE**

62/467, 529, 531; D7/406; D13/162,  
D13/162.1, 164; D14/257

(71) Applicant: **Manitowoc Foodservice Companies, LLC**, Manitowoc, WI (US)

See application file for complete search history.

(72) Inventors: **Marty James Lafond**, Algoma, WI (US); **Mark Paul Giebel**, Manitowoc, WI (US); **Steve David Herning**, Marinette, WI (US); **John Phillip Myers**, Manitowoc, WI (US); **Paula Forseth Dick**, Sheboygan, WI (US); **Curt Richard Cayemberg**, Manitowoc, WI (US)

(56) **References Cited**

U.S. PATENT DOCUMENTS

D563,998	S	*	3/2008	Doberstein et al.	.....	D15/89
D575,310	S	*	8/2008	Bruzelius et al.	.....	D15/89
D577,745	S	*	9/2008	Bruzelius	.....	D15/89
D660,328	S	*	5/2012	Doberstein et al.	.....	D15/89

\* cited by examiner

*Primary Examiner* — Mitchell Siegel

(73) Assignee: **Manitowoc Foodservice Companies, LLC**, Manitowoc, WI (US)

(74) *Attorney, Agent, or Firm* — Ohlandt, Greeley, Ruggiero & Perle, LLP

(\*\*) Term: **14 Years**

(57) **CLAIM**

(21) Appl. No.: **29/464,734**

The ornamental design for an ice machine interface, as shown and described.

(22) Filed: **Aug. 20, 2013**

**DESCRIPTION**

**Related U.S. Application Data**

(63) Continuation of application No. 29/426,885, filed on Jul. 11, 2012, now Pat. No. Des. 690,743.

(51) **LOC (10) Cl.** ..... **15-07**

(52) **U.S. Cl.**  
USPC ..... **D15/89**

(58) **Field of Classification Search**  
USPC ..... D15/79-89; 312/9.1, 236, 352,  
312/400-408, 116, 138.1; 62/3.1, 3.6-3.64,  
62/98, 125, 275, 293, 331, 344, 371, 440,

FIG. 1 is a top side perspective view of an ice machine interface according to the present design in use;  
FIG. 2 is an enlarged top side perspective view of the ice machine interface of FIG. 1;  
FIG. 3 is a side view of the ice machine interface of FIG. 2, the cross-section taken along line 11-11 of FIG. 2; and,  
FIG. 4 is a front view of the ice machine interface of FIG. 2, the cross-section taken along line 12-12 of FIG. 3.  
The broken line showing is included for the purpose of illustrating and forms no part of the claimed design.

**1 Claim, 4 Drawing Sheets**

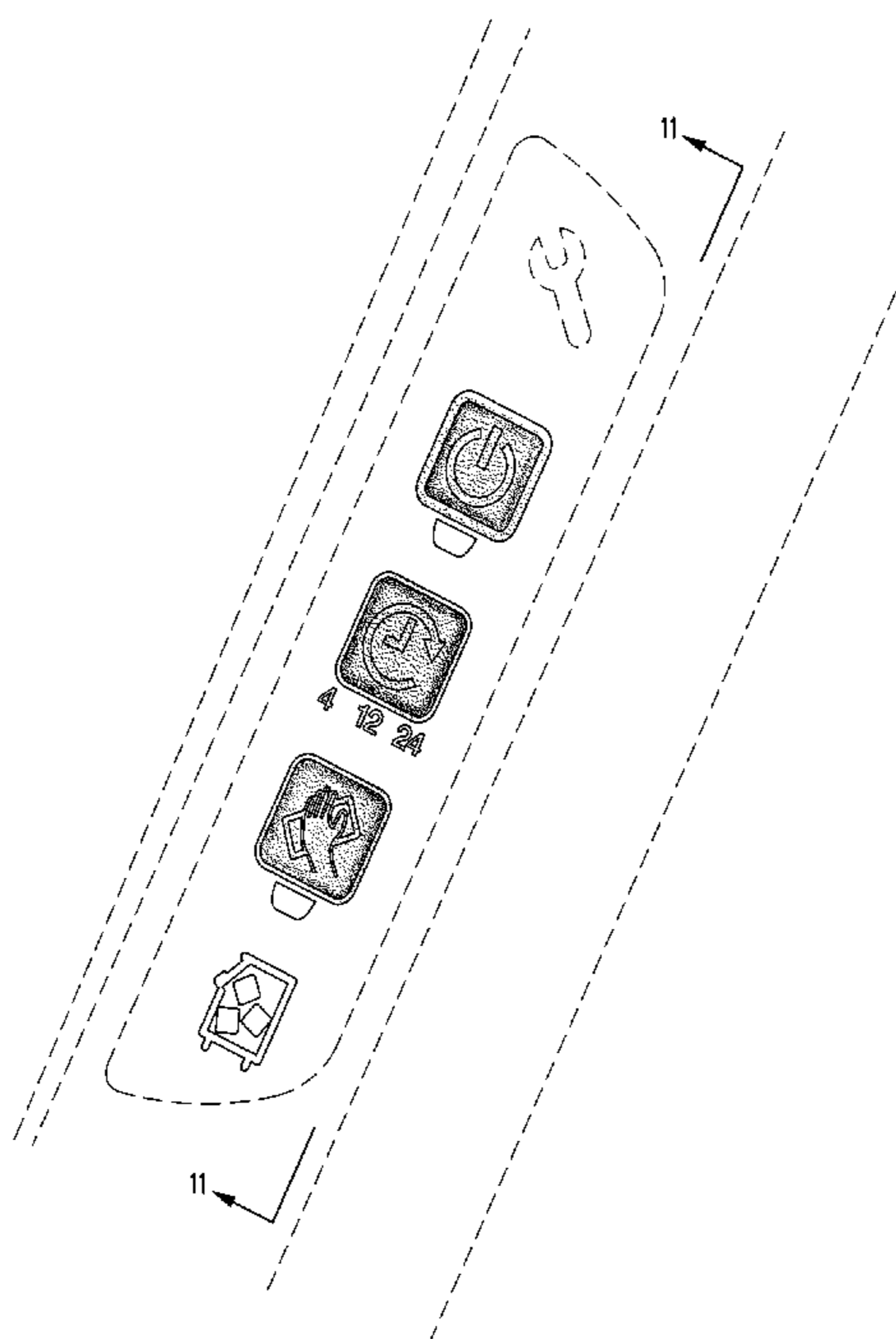

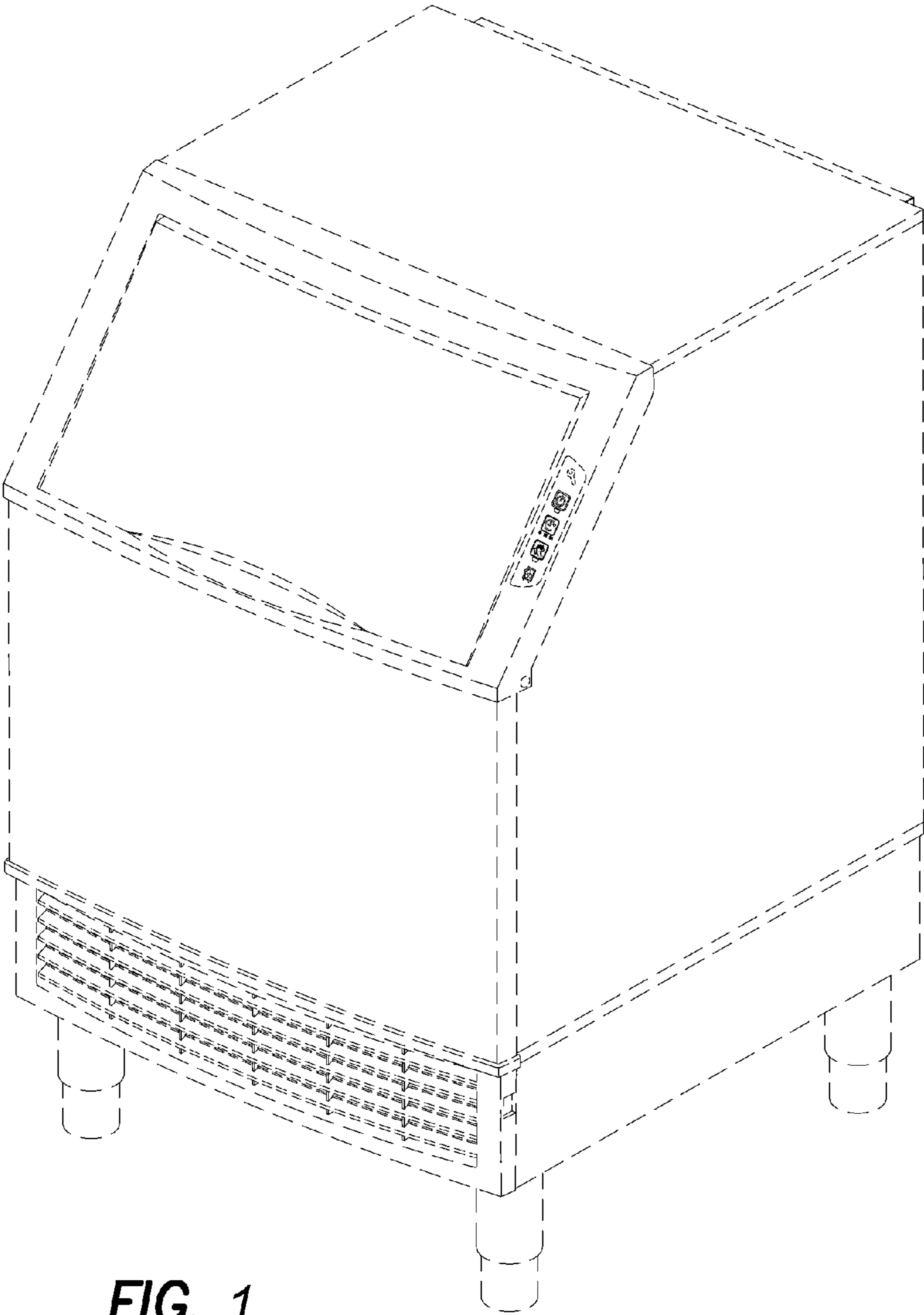

**FIG. 1**

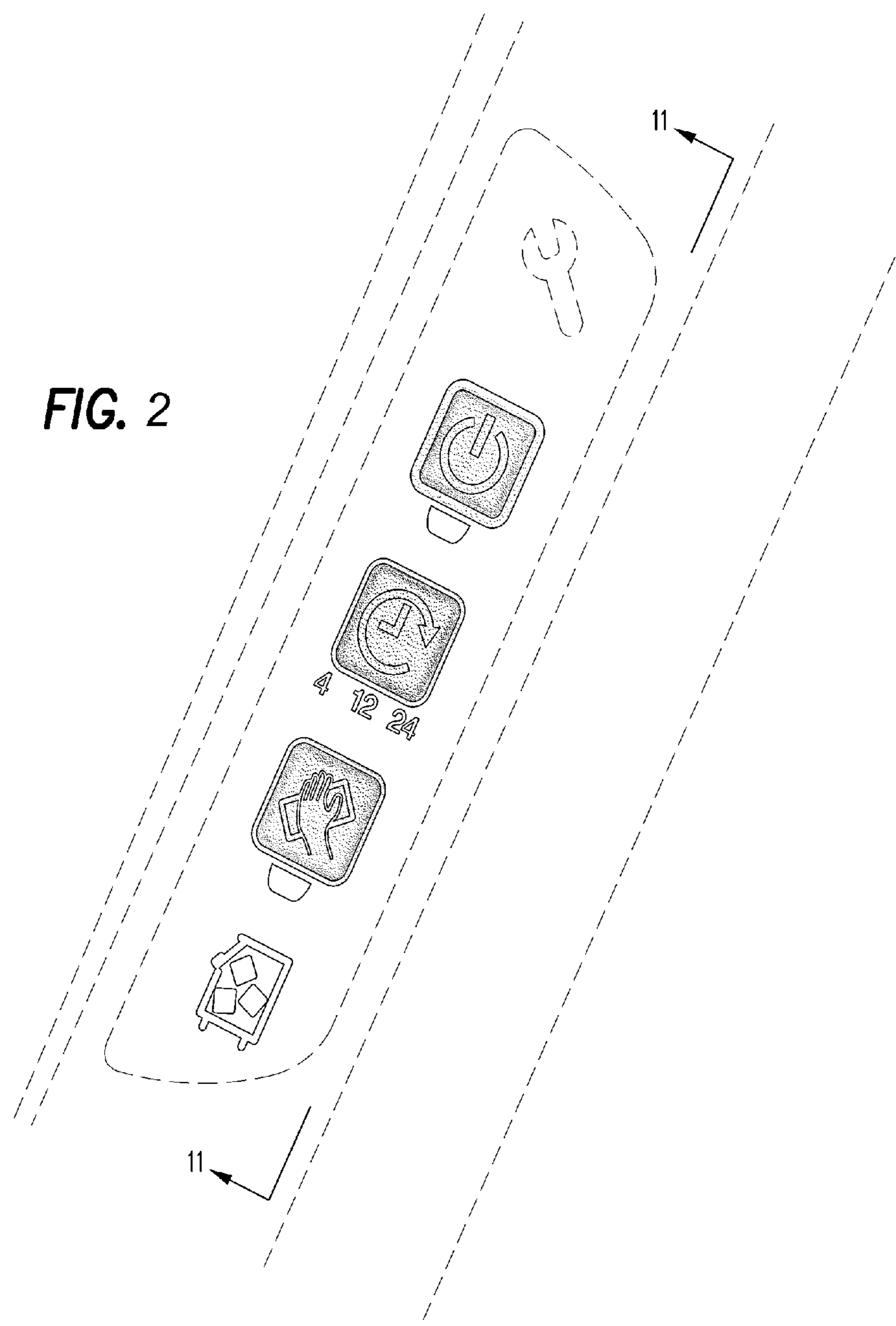
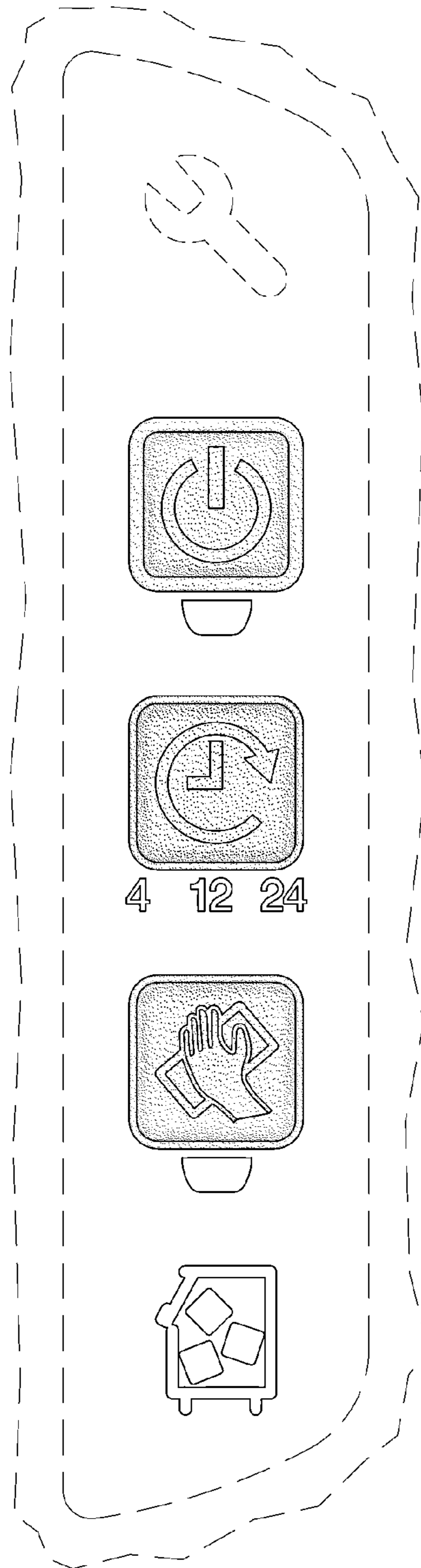



FIG. 3



**FIG. 4**