



US00D705822S

(12) **United States Design Patent**  
**Higashikawa et al.**

(10) **Patent No.:** **US D705,822 S**  
(45) **Date of Patent:** **\*\* May 27, 2014**

(54) **VEHICLE FOR WORK MACHINE**  
(71) Applicant: **Kubota Corporation, Osaka (JP)**  
(72) Inventors: **Yoshitaka Higashikawa, Sakai (JP); Akari Kakudate, Sakai (JP)**  
(73) Assignee: **Kubota Corporation, Osaka (JP)**  
(\*\*) Term: **14 Years**  
(21) Appl. No.: **29/446,763**  
(22) Filed: **Feb. 27, 2013**  
(51) **LOC (10) Cl.** ..... **15-03**  
(52) **U.S. Cl.**  
USPC ..... **D15/22; D15/15**  
(58) **Field of Classification Search**  
USPC ..... D15/14, 15, 17, 21-26, 28, 31, 33;  
180/89.1, 89.12, 900; 56/15.8, 255,  
56/294, 295, 13.3, 13.4, 16.6, 16.7, 17.1,  
56/202, 320.1, 320.2  
See application file for complete search history.

5,915,496 A \* 6/1999 Bednar et al. .... 180/305  
D442,972 S \* 5/2001 Wolf ..... D15/15  
D455,156 S \* 4/2002 Rittfeldt ..... D15/10  
D538,302 S \* 3/2007 Higashikawa ..... D15/15  
D560,690 S \* 1/2008 Higashikawa ..... D15/10  
D583,836 S \* 12/2008 Matsumoto et al. .... D15/28  
D584,321 S \* 1/2009 Matsumoto et al. .... D15/28  
D594,885 S \* 6/2009 Kuwae et al. .... D15/28  
D626,572 S \* 11/2010 Moriguchi et al. .... D15/15  
D636,001 S \* 4/2011 Martin et al. .... D15/33  
D637,625 S \* 5/2011 Thunstrom et al. .... D15/15  
D654,512 S \* 2/2012 Naslund ..... D15/17  
D656,965 S \* 4/2012 Ortlund et al. .... D15/17  
D669,504 S \* 10/2012 Higashikawa ..... D15/28  
D681,685 S \* 5/2013 Higashikawa ..... D15/15  
D692,466 S \* 10/2013 Takagi et al. .... D15/28

\* cited by examiner

*Primary Examiner* — Mark Goodwin  
(74) *Attorney, Agent, or Firm* — The Webb Law Firm

(57) **CLAIM**  
The ornamental design for a vehicle for work machine, as shown and described.

**DESCRIPTION**

FIG. 1 is a left side view of a vehicle for work machine showing our new design;  
FIG. 2 is a right side view thereof;  
FIG. 3 is a rear view thereof;  
FIG. 4 is a front view thereof;  
FIG. 5 is a top view thereof;  
FIG. 6 is an upper left front perspective view thereof; and,  
FIG. 7 is an upper right rear perspective view thereof.  
A bottom view is omitted because it is plain and unornamental and forms no part of the subject matter of the claimed design.

**1 Claim, 7 Drawing Sheets**

(56) **References Cited**  
U.S. PATENT DOCUMENTS  
D242,940 S \* 1/1977 Ehrlin et al. .... D15/15  
D249,267 S \* 9/1978 Brackin et al. .... D15/15  
D271,020 S \* 10/1983 Malmberg et al. .... D15/15  
D326,662 S \* 6/1992 Holm et al. .... D15/17  
D340,459 S \* 10/1993 Kawakita et al. .... D15/15  
D340,936 S \* 11/1993 Matsuda et al. .... D15/15  
D362,447 S \* 9/1995 Lamb ..... D15/15  
D363,495 S \* 10/1995 Good et al. .... D15/15  
5,540,037 A \* 7/1996 Lamb et al. .... 56/7  
D380,761 S \* 7/1997 Saylor ..... D15/15  
D389,490 S \* 1/1998 Shimamura et al. .... D15/15  
D392,981 S \* 3/1998 Smith ..... D15/15  
D397,121 S \* 8/1998 Smith ..... D15/15

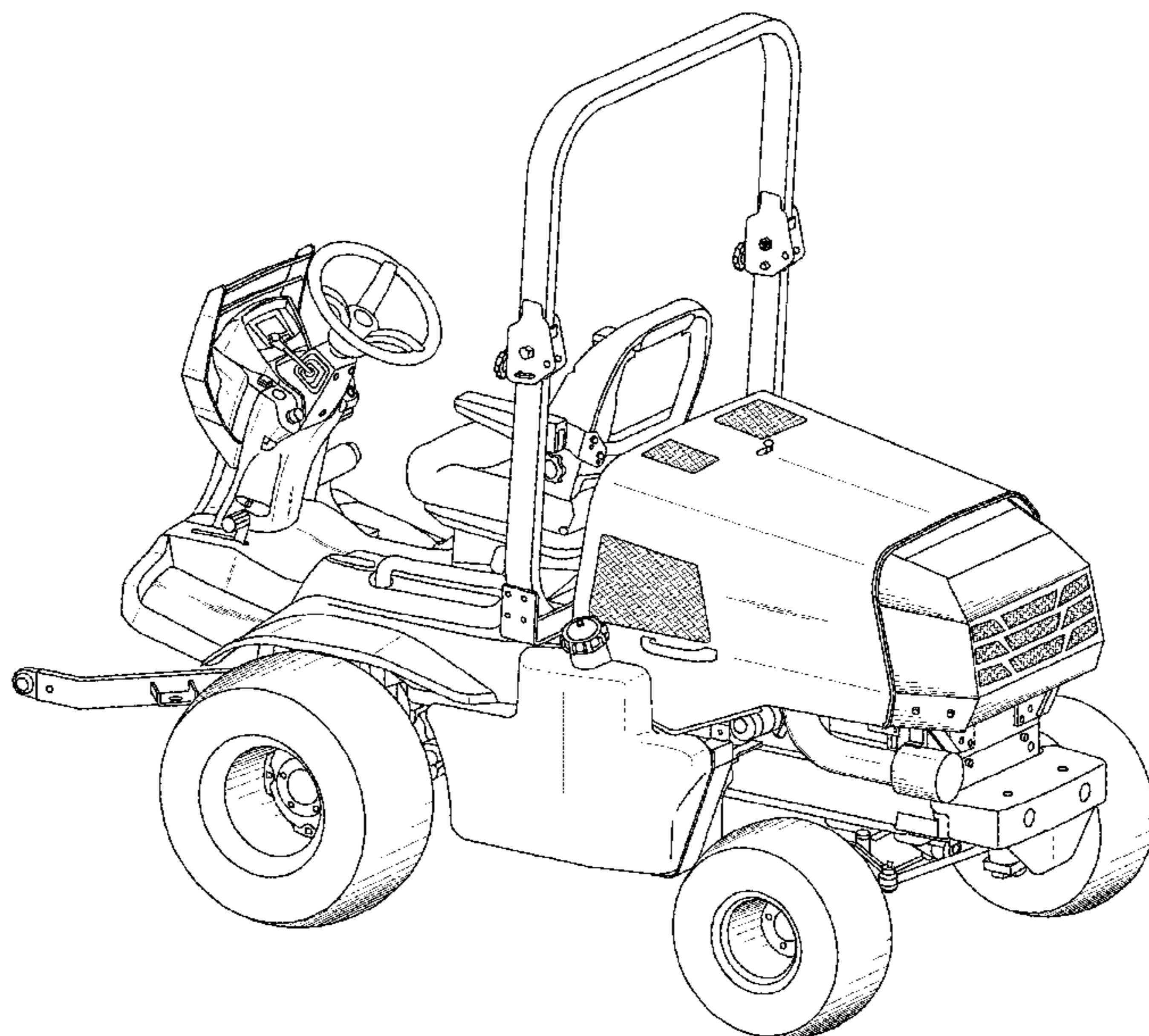

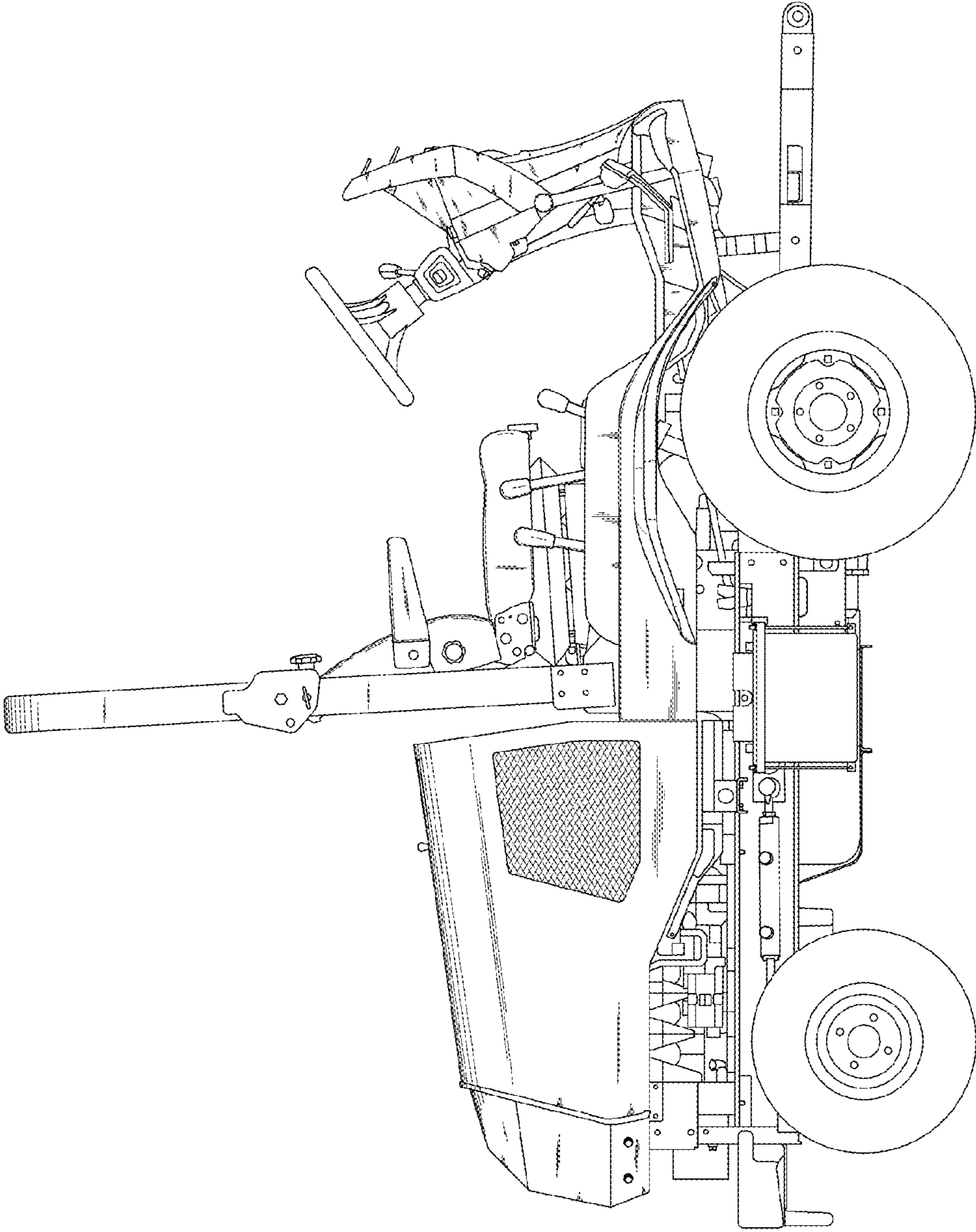

FIG. 1

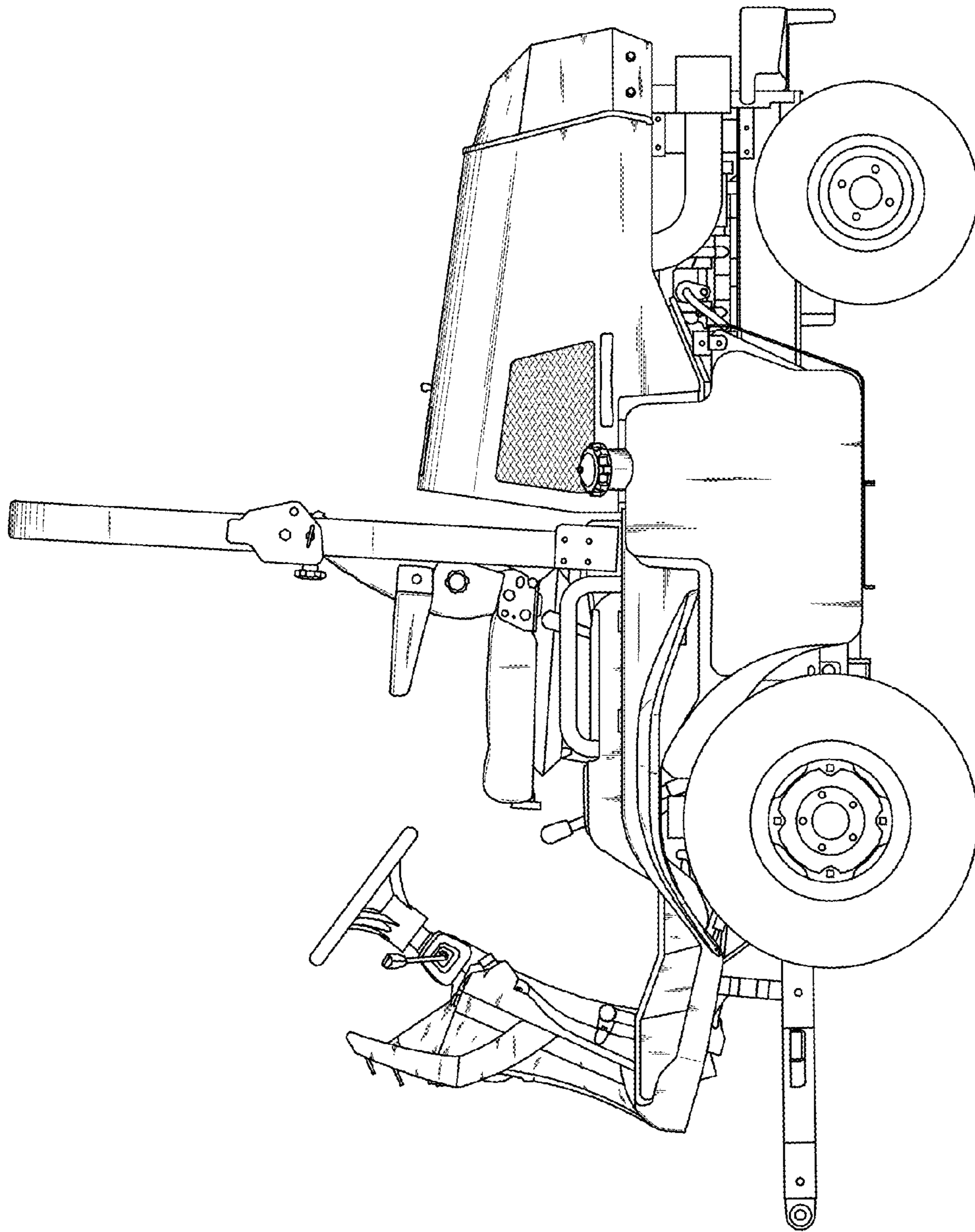
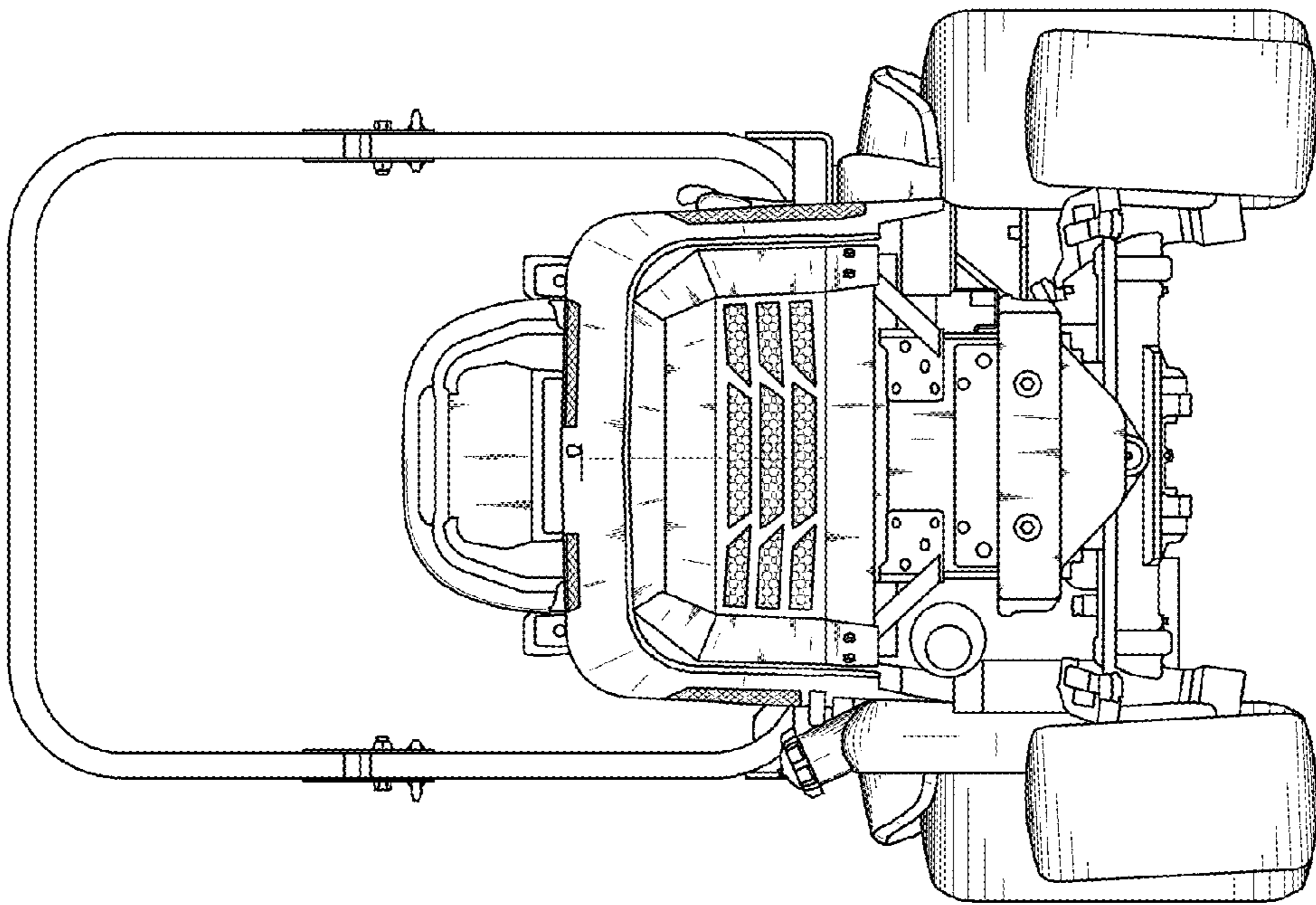
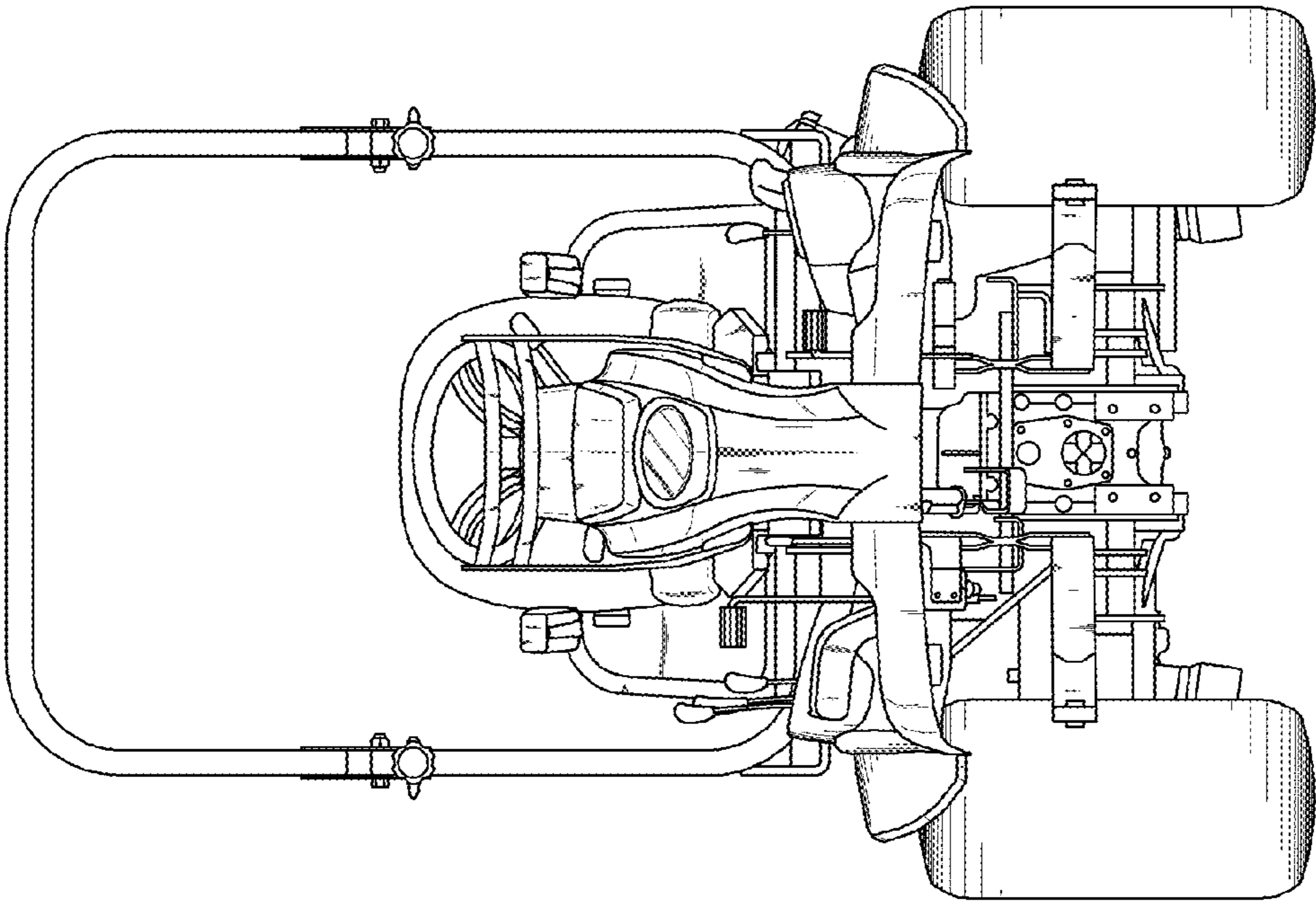

FIG. 2

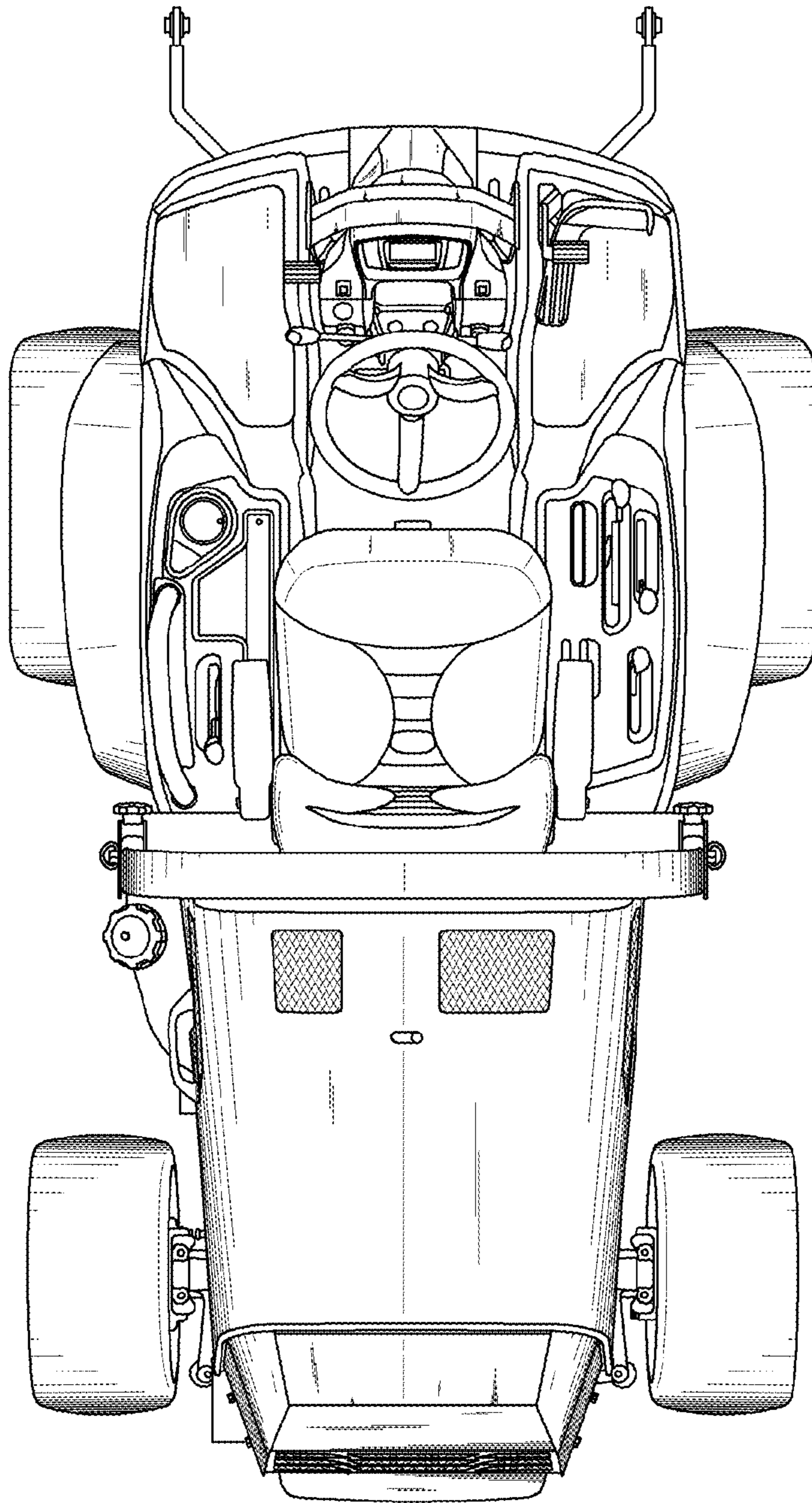



**FIG. 3**



**FIG. 4**



**FIG. 5**

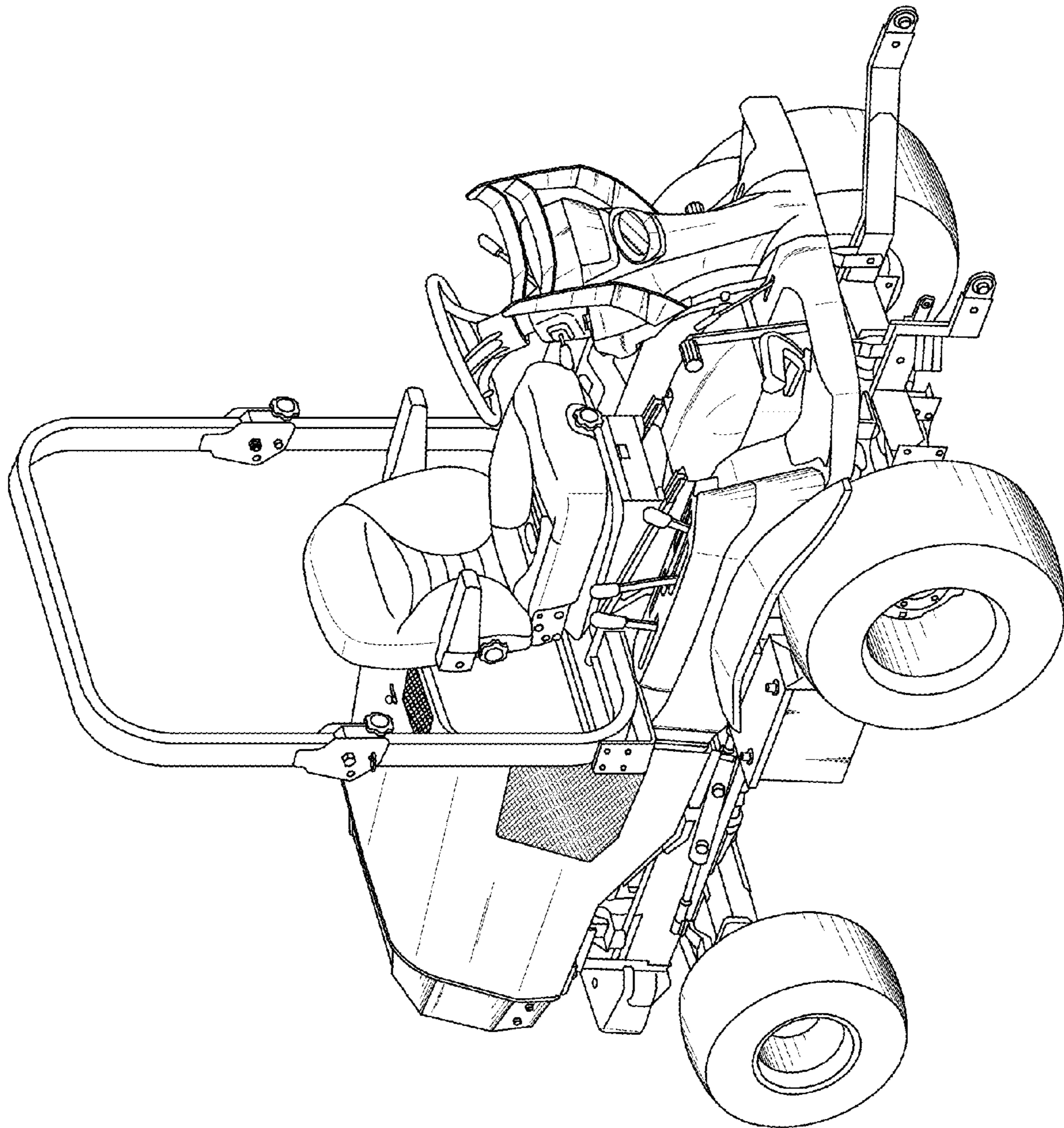

**FIG. 6**



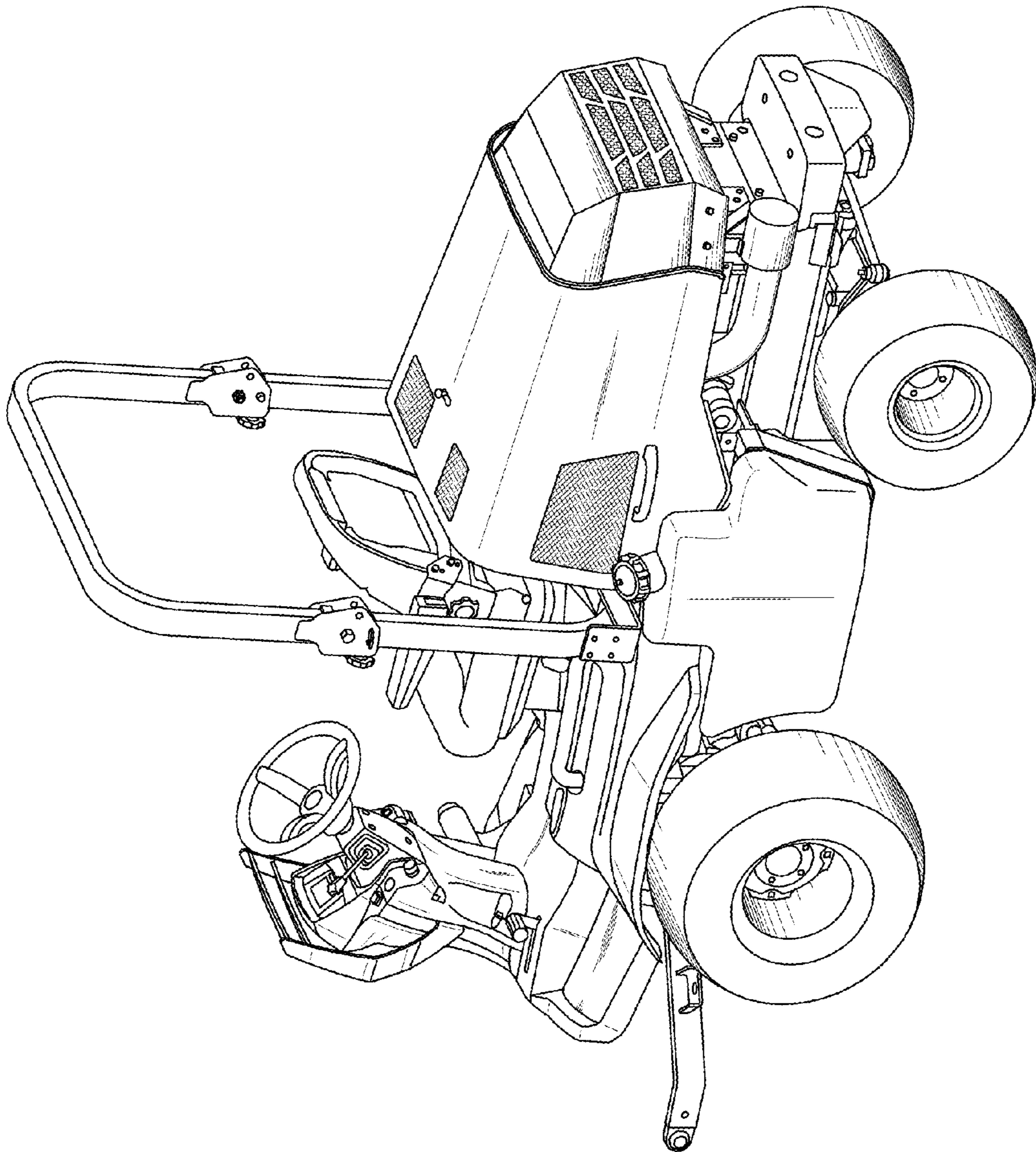

FIG. 7