



US00D705714S

(12) **United States Design Patent**
Hanaoka

(10) **Patent No.:** **US D705,714 S**

(45) **Date of Patent:** **** May 27, 2014**

(54) **WHEEL FOR AN AUTOMOBILE**

(71) Applicant: **Honda Motor Co., Ltd.**, Tokyo (JP)

(72) Inventor: **Hisakazu Hanaoka**, Saitama (JP)

(73) Assignee: **Honda Motor Co., Ltd.**, Tokyo (JP)

(**) Term: **14 Years**

(21) Appl. No.: **29/475,059**

(22) Filed: **Nov. 27, 2013**

(30) **Foreign Application Priority Data**

May 31, 2013 (JP) 2013-012171

(51) **LOC (10) Cl.** **12-16**

(52) **U.S. Cl.**
USPC **D12/209**

(58) **Field of Classification Search**
USPC D12/204-213; 301/37.101, 64.101, 65,
301/64.201

See application file for complete search history.

(56) **References Cited**

U.S. PATENT DOCUMENTS

D497,861 S * 11/2004 Brintouch et al. D12/209
D504,096 S * 4/2005 Nakagawa et al. D12/209

D619,524 S * 7/2010 Gabath D12/209
D619,951 S * 7/2010 Baum D12/209
D652,361 S * 1/2012 Forschner D12/209
D654,842 S * 2/2012 Blasi D12/209
D663,248 S * 7/2012 Kogawa D12/209
D665,322 S * 8/2012 Kim D12/204
D671,478 S * 11/2012 Baum et al. D12/209
D685,710 S * 7/2013 Hanaoka D12/209
D695,184 S * 12/2013 Pollmann D12/209
D695,190 S * 12/2013 Goto D12/209
D695,191 S * 12/2013 Kogawa D12/209

* cited by examiner

Primary Examiner — Stacia Cadmus

(74) *Attorney, Agent, or Firm* — Westerman, Hattori,
Daniels & Adrian, LLP

(57) **CLAIM**

The ornamental design for a wheel for an automobile, as shown and described.

DESCRIPTION

FIG. 1 is a front perspective view of a wheel for an automobile showing my new design;

FIG. 2 is an enlarged front perspective view of a portion thereof; and,

FIG. 3 is a front elevational view thereof.

The broken lines illustrate environmental structure only and form no part of the claimed design.

1 Claim, 3 Drawing Sheets

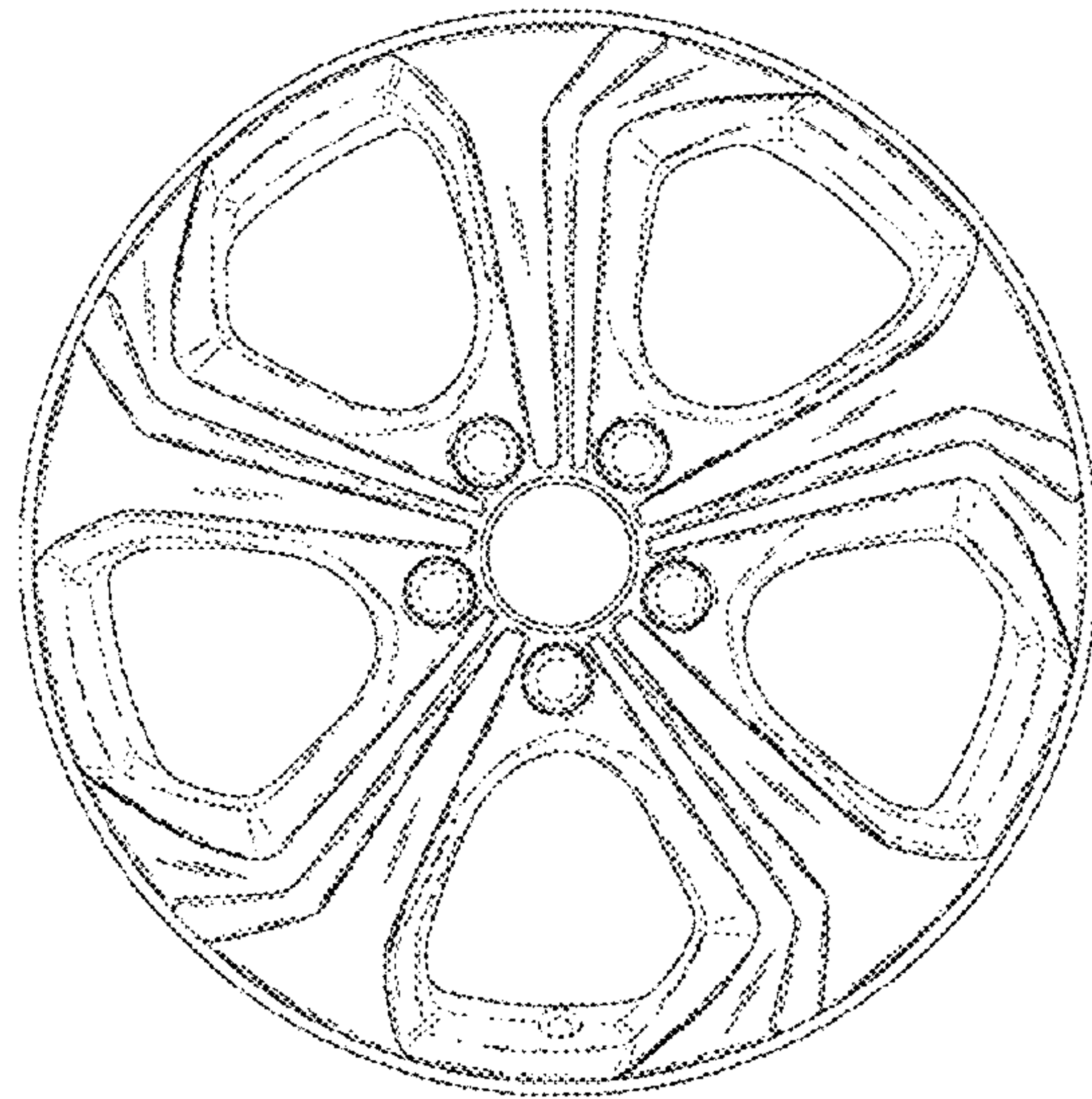
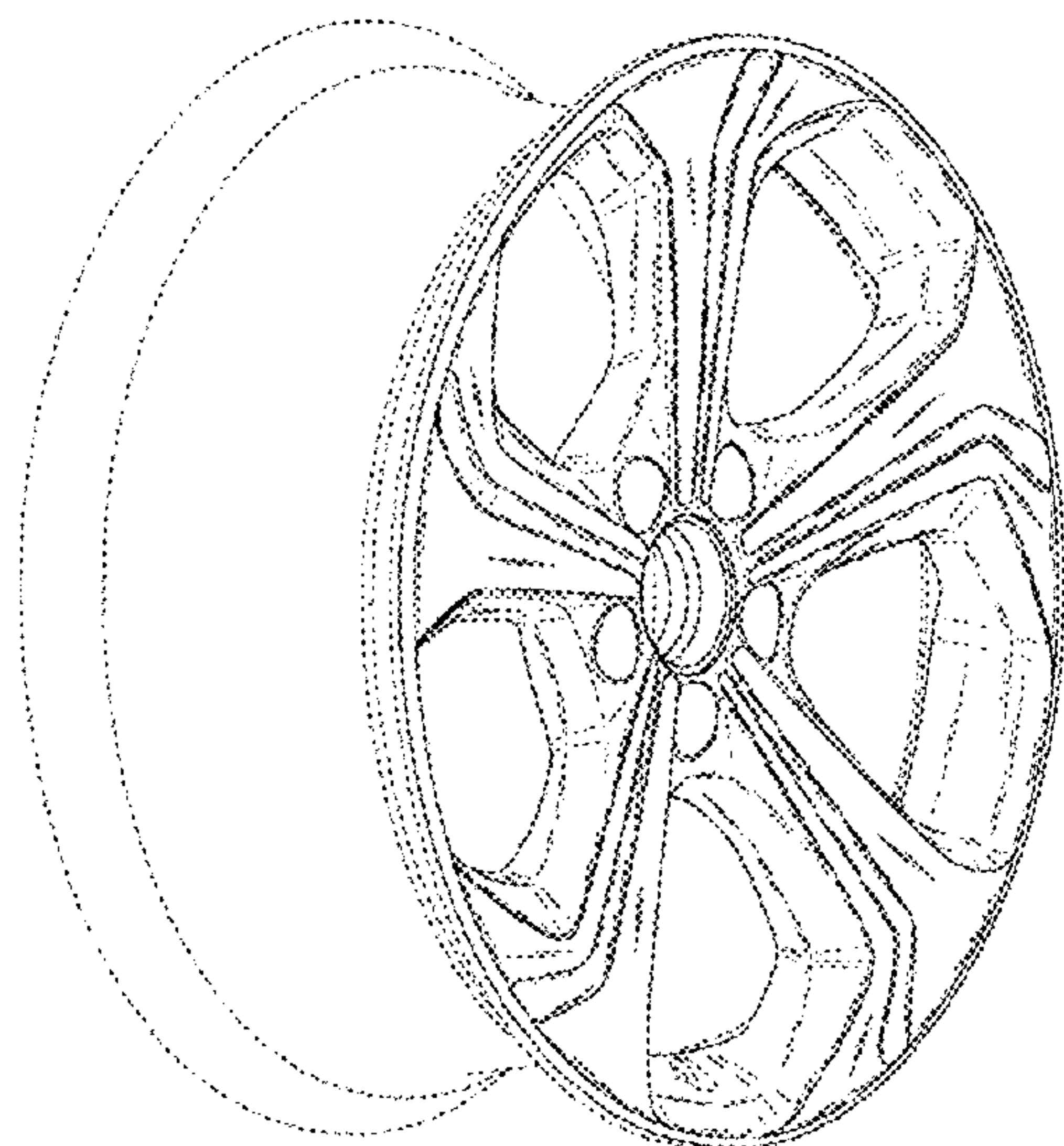

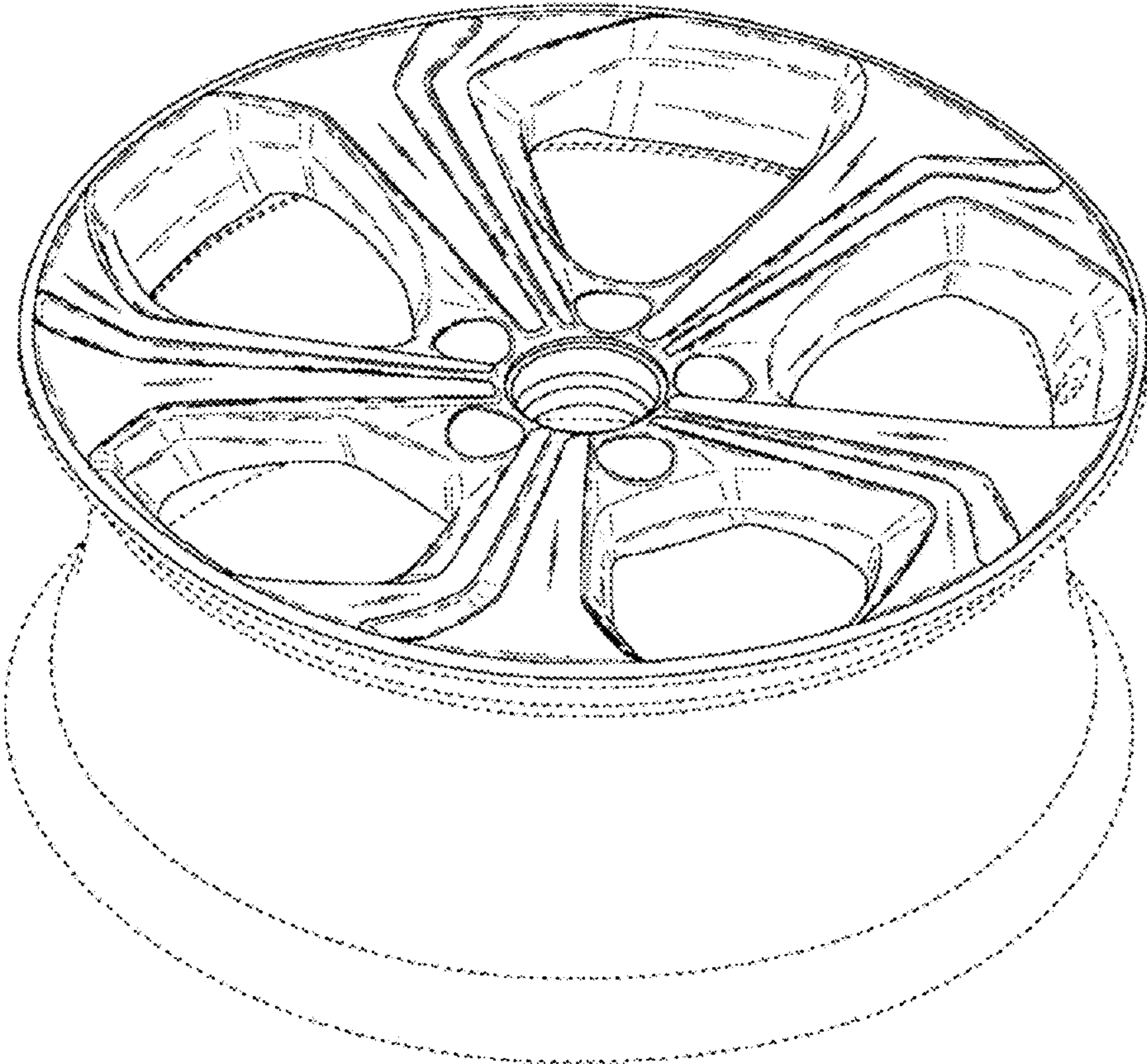

FIG.1

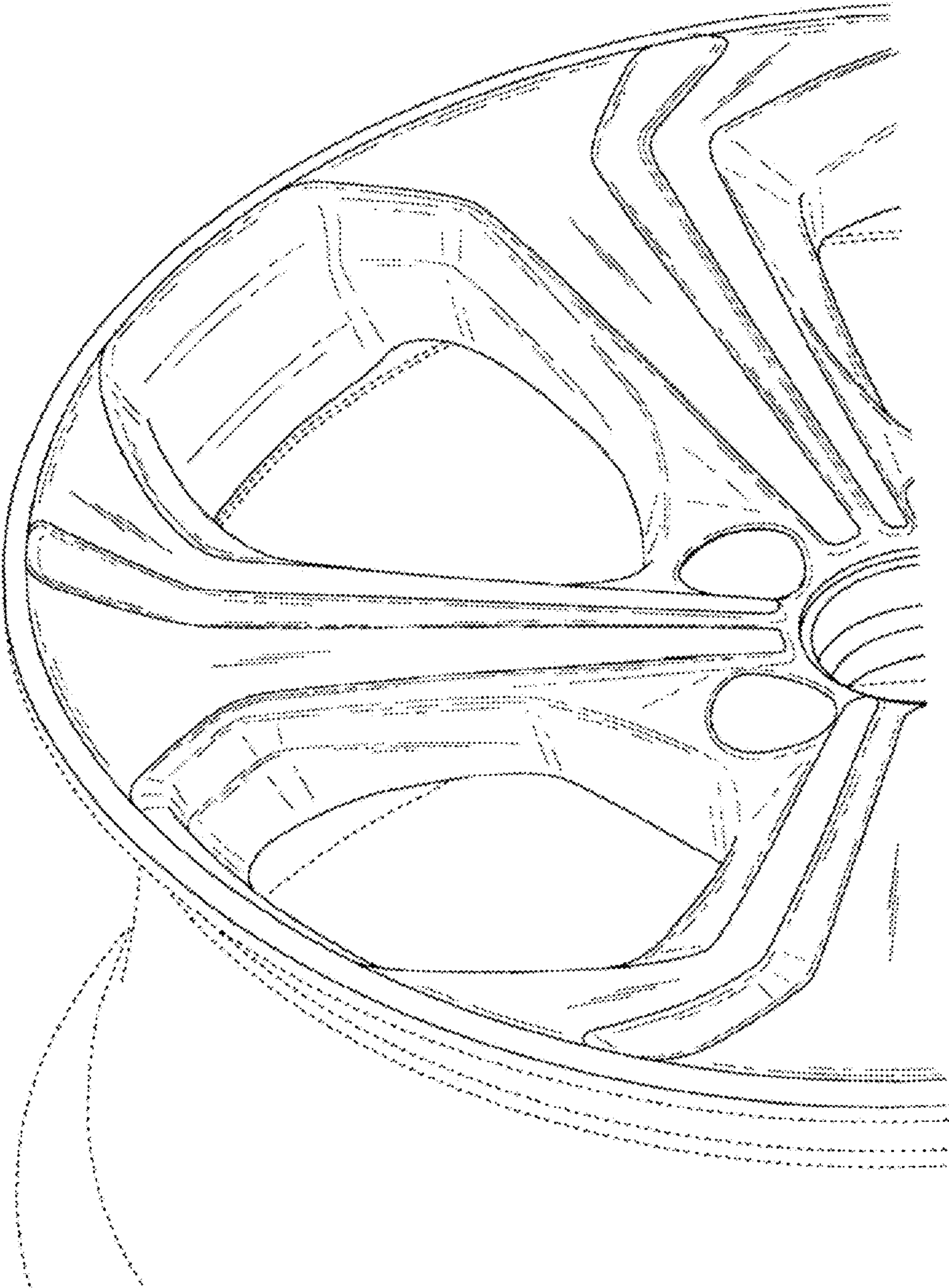

FIG.2

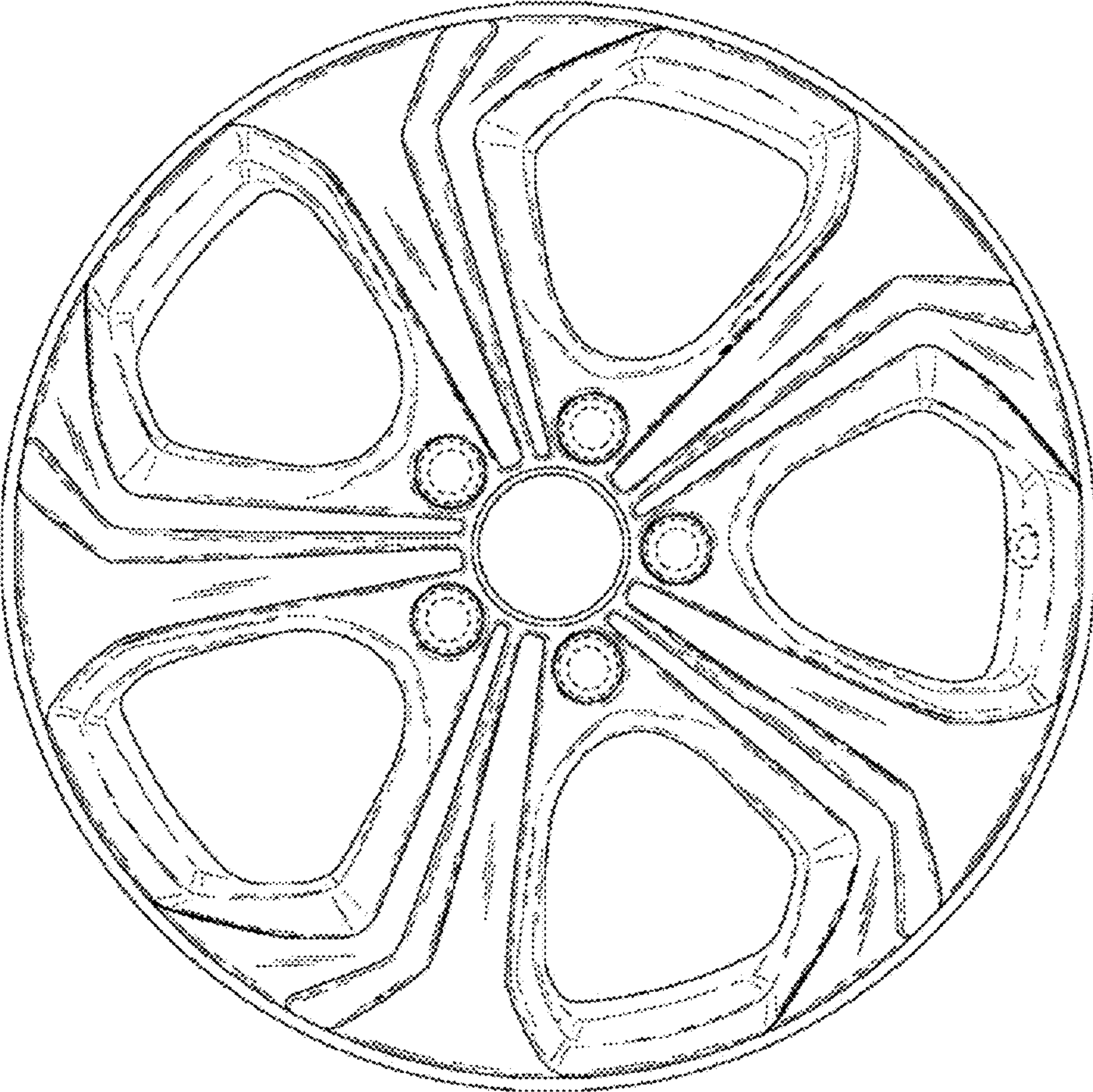

FIG.3