



US00D705682S

(12) **United States Design Patent**  
**Stowers**

(10) **Patent No.:** **US D705,682 S**

(45) **Date of Patent:** **\*\* May 27, 2014**

- (54) **AUTOMOTIVE SAFETY DEVICE**
- (71) Applicant: **Measurement Ltd.**, Grand Cayman (KY)
- (72) Inventor: **David C. Stowers**, Morristown, NJ (US)
- (73) Assignee: **Measurement Ltd.**, Grand Cayman (KY)
- (\*\*) Term: **14 Years**
- (21) Appl. No.: **29/435,766**
- (22) Filed: **Oct. 28, 2012**
- (51) **LOC (10) Cl.** ..... **10-04**
- (52) **U.S. Cl.**  
USPC ..... **D10/86; D8/105; D10/113.4; D26/51**
- (58) **Field of Classification Search**  
USPC ..... **D10/85-86, 109.1, 109.2, 113.4, 114.1, D10/114.9; 73/146.3, 146.8, 700-713, 717; D8/81, 105; D26/93, 104, 110, 51, D26/144; 404/9, 10, 72, 16, 12-15; 362/8, 362/311, 153, 153.1, 431, 410-414; 359/547, 531; 340/908, 908.1, 815.45, 340/332, 468; 116/63; 248/165, 164, 163, 248/162, 170, 171, 176.1, 122.1, 219.3; 182/18; 40/607.11, 610**  
See application file for complete search history.

(56) **References Cited**

**U.S. PATENT DOCUMENTS**

- D279,770 S \* 7/1985 Parker ..... D10/114.1
- 4,631,831 A 12/1986 Bacher et al.

(Continued)

*Primary Examiner* — Antoine D Davis

(74) *Attorney, Agent, or Firm* — Howard IP Law Group, PC

(57) **CLAIM**

The ornamental design for an automotive safety device, as shown and described.

**DESCRIPTION**

FIG. 1 is a perspective view of an automotive safety device showing my new design in a closed configuration, according to an embodiment of the invention;

FIG. 2 is a right side elevational view of the automotive safety device of FIG. 1;

FIG. 3 is a top view of the automotive safety device of FIG. 1;

FIG. 4 is a bottom view of the automotive safety device of FIG. 1;

FIG. 5 is a rear elevational view of the automotive safety device of FIG. 1;

FIG. 6 is a front elevational view of the automotive safety device of FIG. 1;

FIG. 7 is a perspective view of the automotive safety device of FIG. 1, shown in an open configuration;

FIG. 8 is a right side elevational view of the automotive safety device of FIG. 7;

FIG. 9 is a top view of the automotive safety device of FIG. 7;

FIG. 10 is a bottom view of the automotive safety device of FIG. 7;

FIG. 11 is a rear elevational view of the automotive safety device of FIG. 7;

FIG. 12 is a front elevational view of the automotive safety device of FIG. 7;

FIG. 13 is a perspective view of an automotive safety device according to another embodiment of the present invention shown in an open configuration;

FIG. 14 is a right side elevational view of the automotive safety device of FIG. 13;

FIG. 15 is a top view of the automotive safety device of FIG. 13;

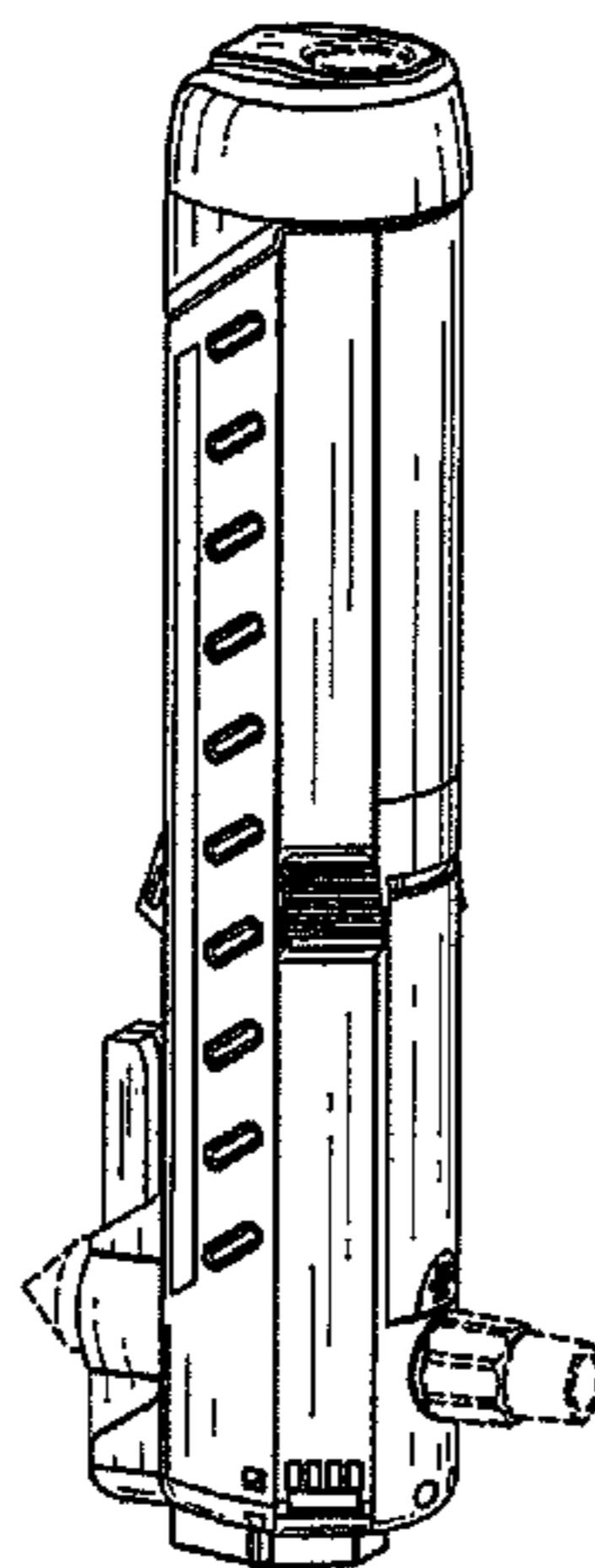
FIG. 16 is a bottom view of the automotive safety device of FIG. 13;

FIG. 17 is a rear elevational view of the automotive safety device of FIG. 13; and,

FIG. 18 is a front elevational view of the automotive safety device of FIG. 13.

The matter shown in dashed lines is environmental structure and forms no part of the claimed design.

**1 Claim, 15 Drawing Sheets**



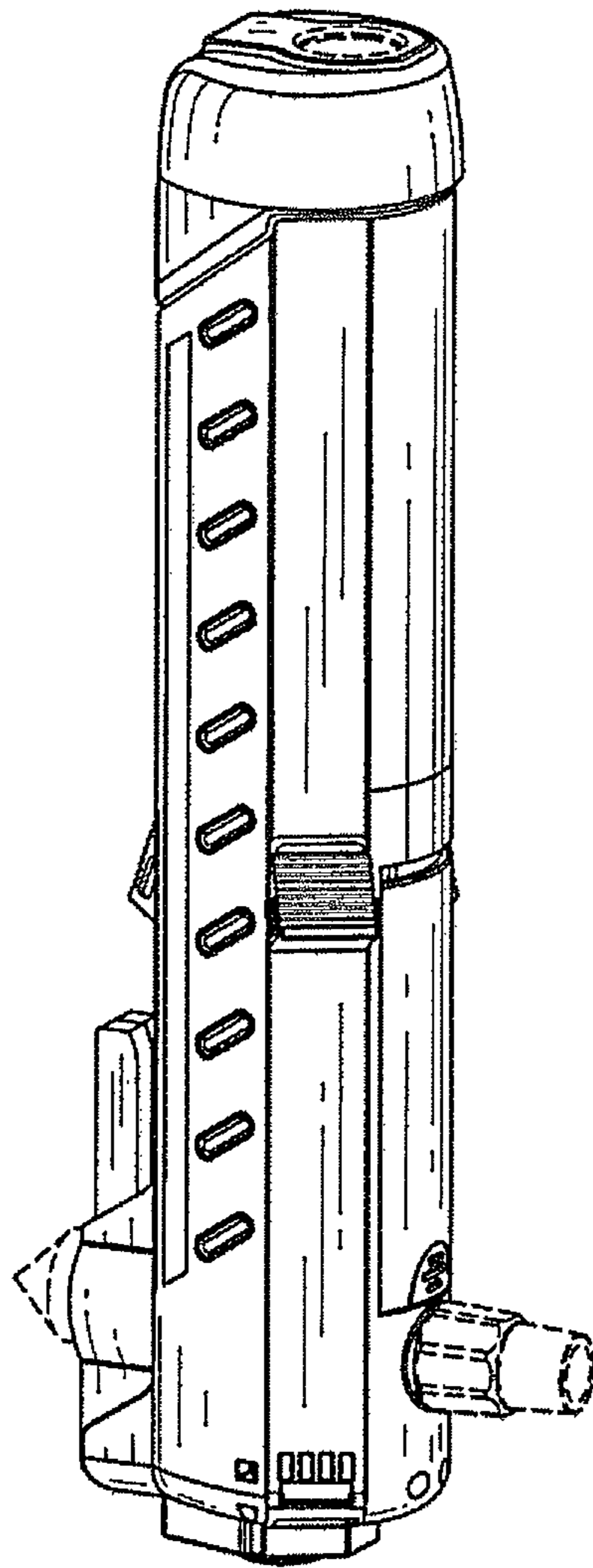
(56)

References Cited

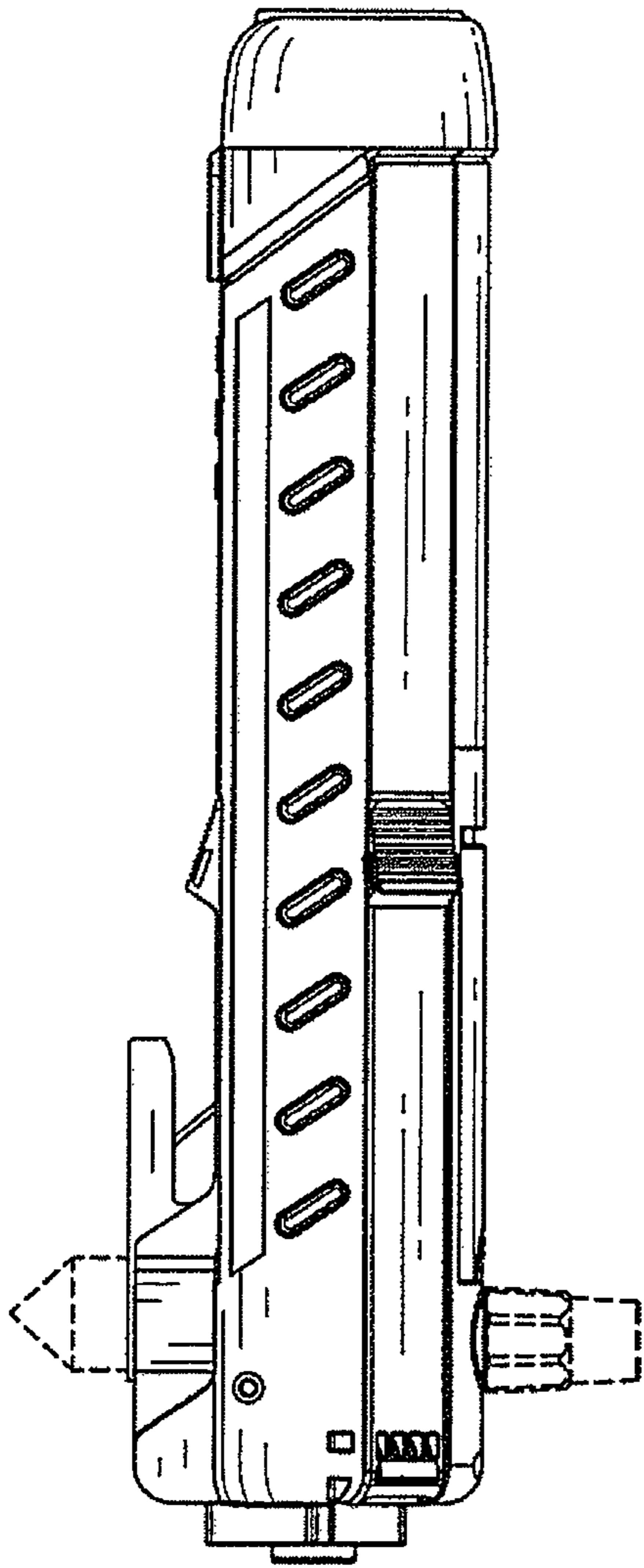
U.S. PATENT DOCUMENTS

4,800,931 A *	1/1989	Petkovsek .....	141/65	D462,627 S	9/2002	Petrucelli	
4,970,894 A	11/1990	Huang		6,634,223 B2	10/2003	Hartmann et al.	
D317,880 S	7/1991	Meehan		D514,009 S *	1/2006	Parr et al. ....	D10/113.2
D366,846 S	2/1996	Handfield et al.		7,010,969 B1	3/2006	Huang	
D383,867 S *	9/1997	Shalvi .....	D26/68	D522,894 S	6/2006	Stowers et al.	
D390,140 S	2/1998	Germanton		D524,667 S	7/2006	Fujioka	
D395,835 S	7/1998	Okuyama et al.		D524,669 S	7/2006	Stowers et al.	
5,883,306 A	3/1999	Hwang		D526,229 S	8/2006	Stowers et al.	
5,895,845 A	4/1999	Burger		D526,589 S	8/2006	Stowers et al.	
D409,509 S	5/1999	Petrucelli et al.		D526,922 S	8/2006	Stowers et al.	
D409,931 S	5/1999	Petrucelli et al.		D528,934 S	9/2006	Stowers et al.	
5,987,978 A	11/1999	Whitehead		D534,092 S	12/2006	Kuskovsky	
D440,893 S *	4/2001	Van Zeyl .....	D10/86	D564,383 S	3/2008	Petrucelli et al.	
D440,894 S	4/2001	Van Zeyl		D596,970 S	7/2009	Petrucelli	
D440,895 S	4/2001	Van Zeyl		D603,733 S	11/2009	Stowers et al.	
D441,674 S	5/2001	Van Zeyl		D606,435 S	12/2009	Zheng	
D447,970 S	9/2001	Cappiello et al.		D631,766 S	2/2011	Petrucelli	
D450,257 S	11/2001	Bressler et al.		D631,768 S	2/2011	Petrucelli et al.	
D455,666 S	4/2002	Cappiello et al.		7,928,960 B2	4/2011	Baldo et al.	
D459,257 S	6/2002	Petrucelli		D648,236 S	11/2011	Rodrig	
D459,668 S	7/2002	Petrucelli		D671,017 S	11/2012	Petrucelli et al.	
				D671,025 S	11/2012	Stowers	
				8,319,662 B1 *	11/2012	Bontemps et al. ....	340/908
				D683,643 S	6/2013	Stowers et al.	

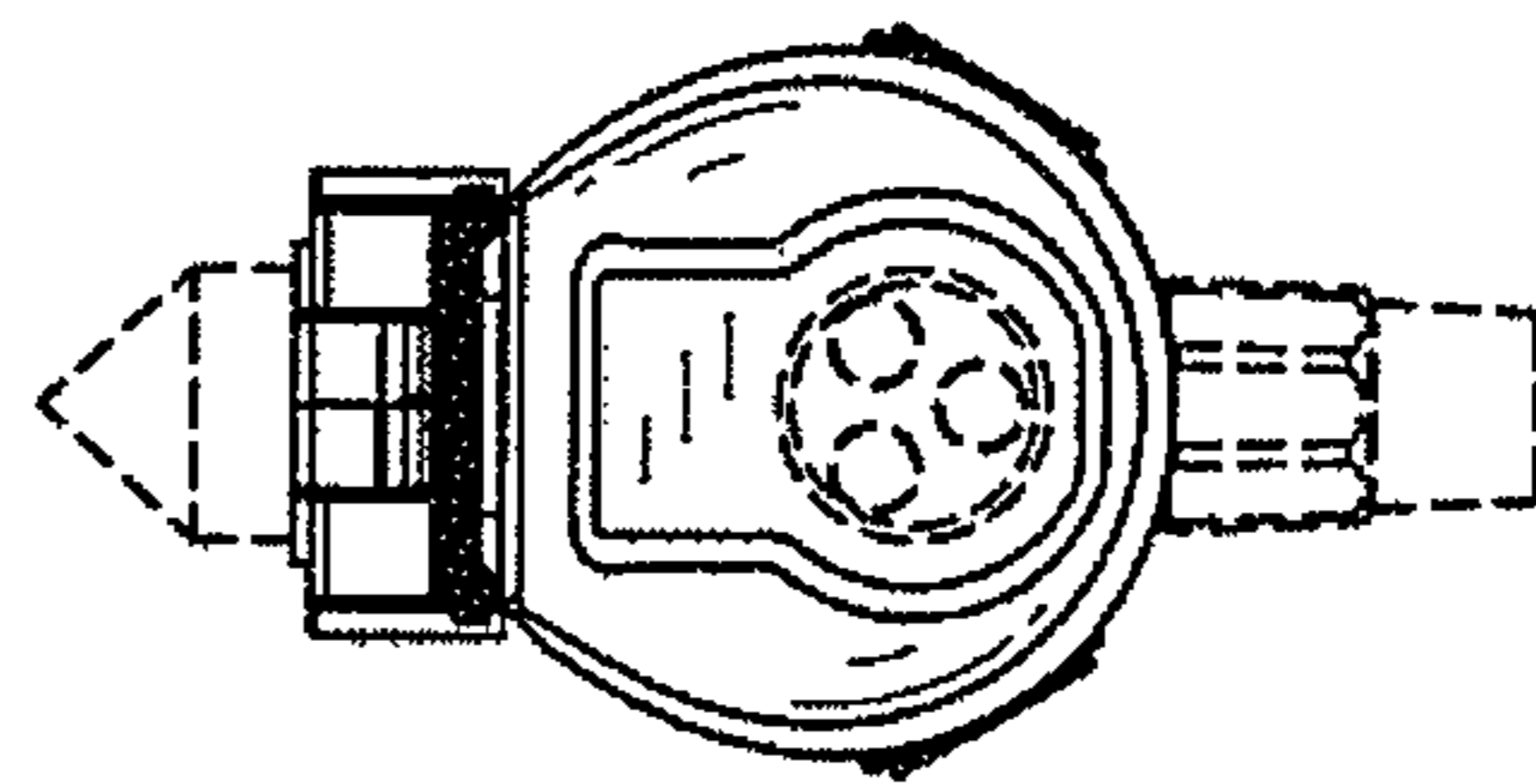
\* cited by examiner



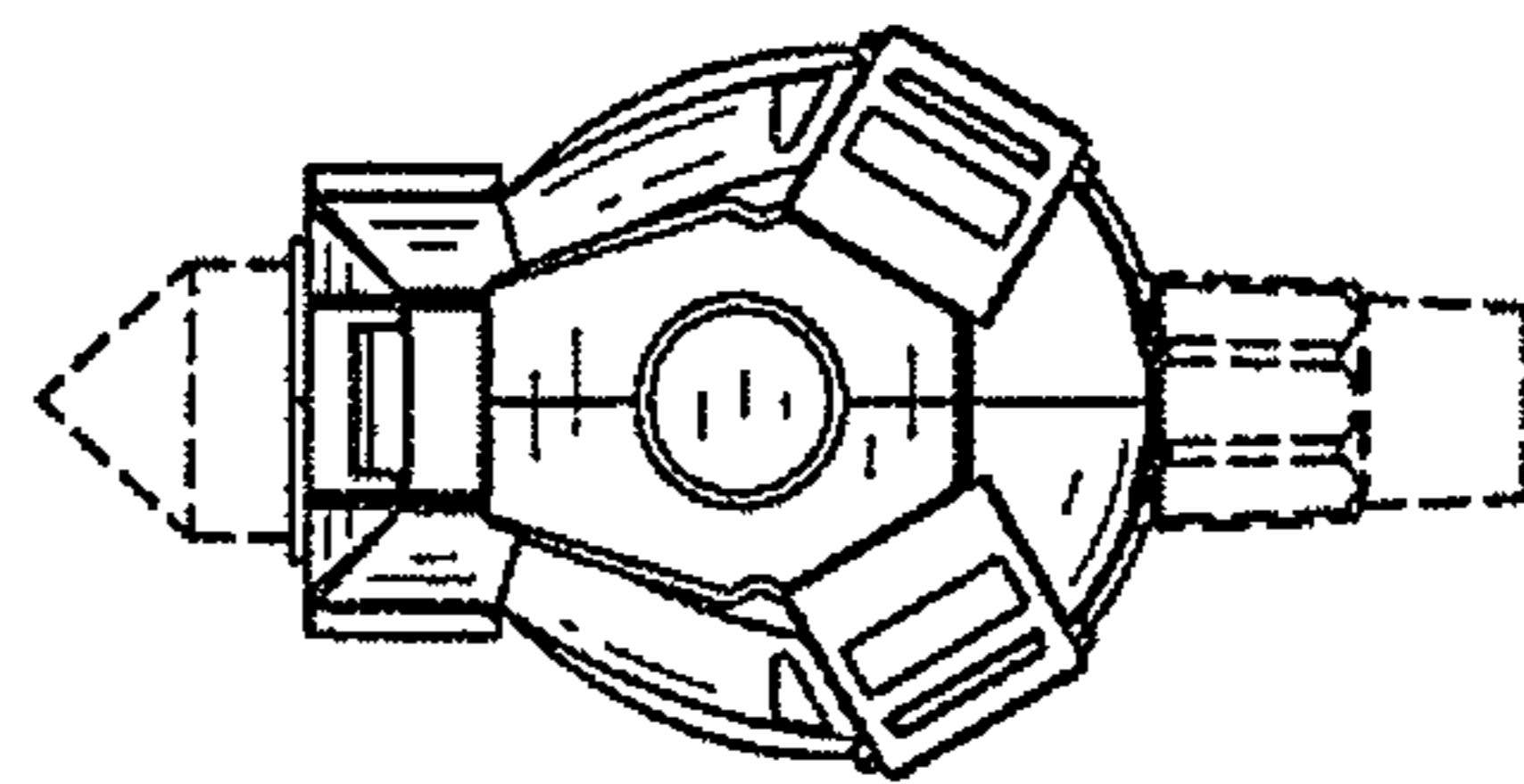
*Fig. 1*



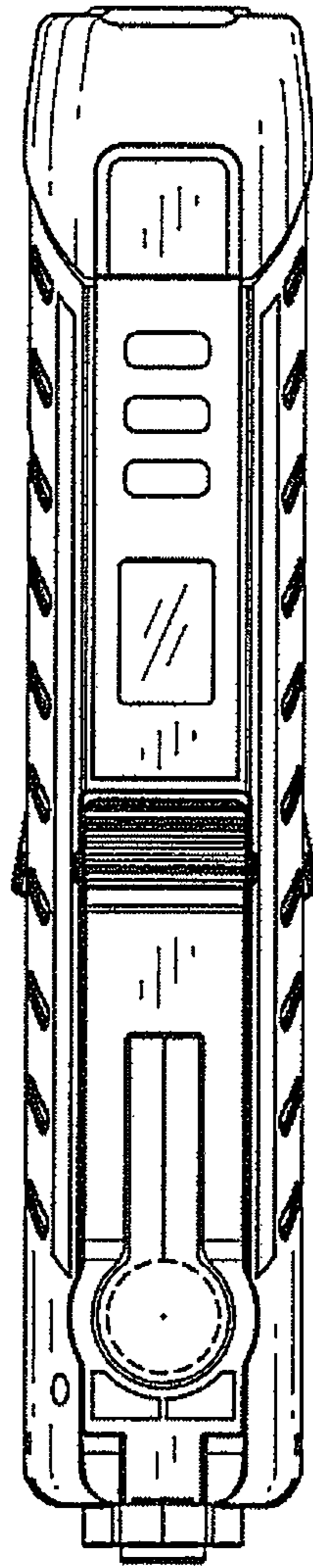
*Fig. 2*



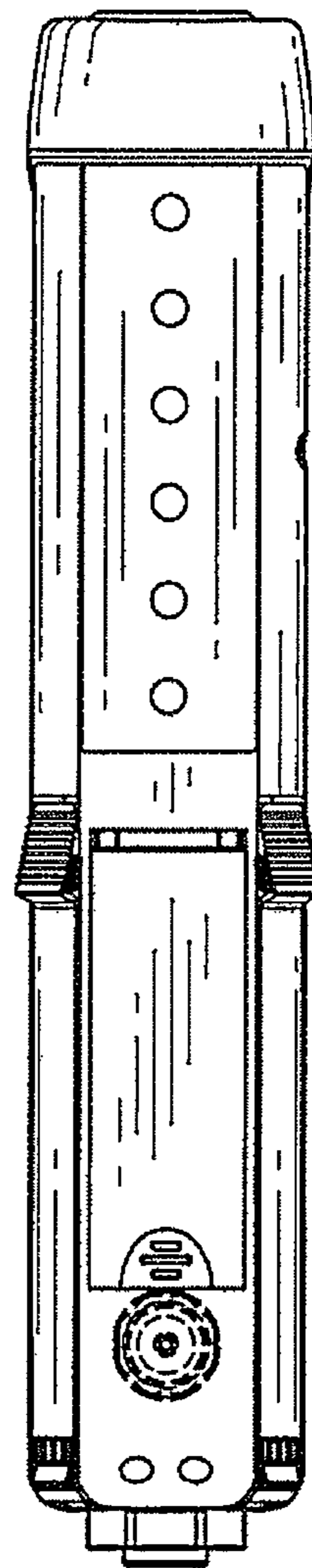
*Fig. 3*



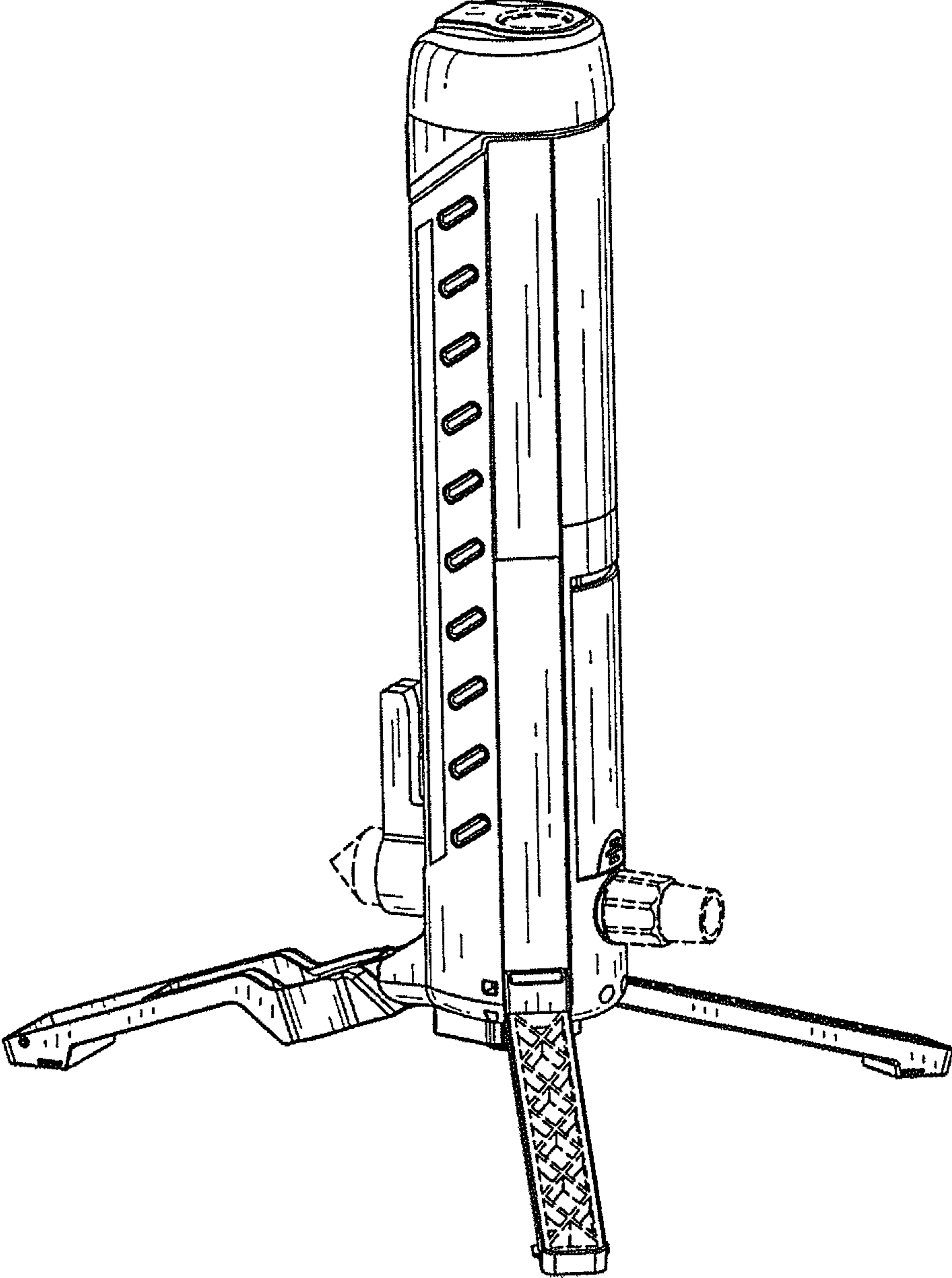
*Fig. 4*



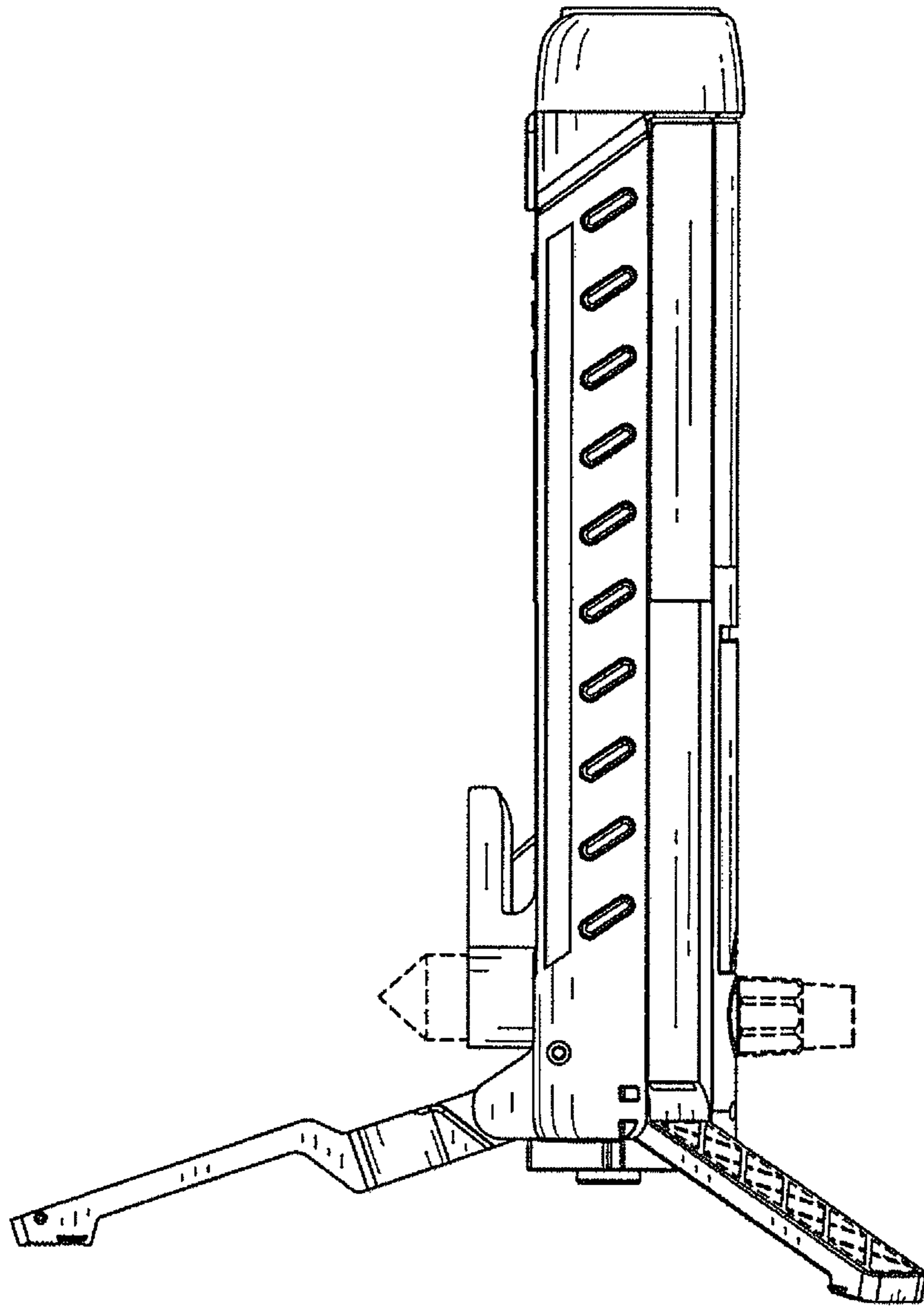
*Fig. 5*



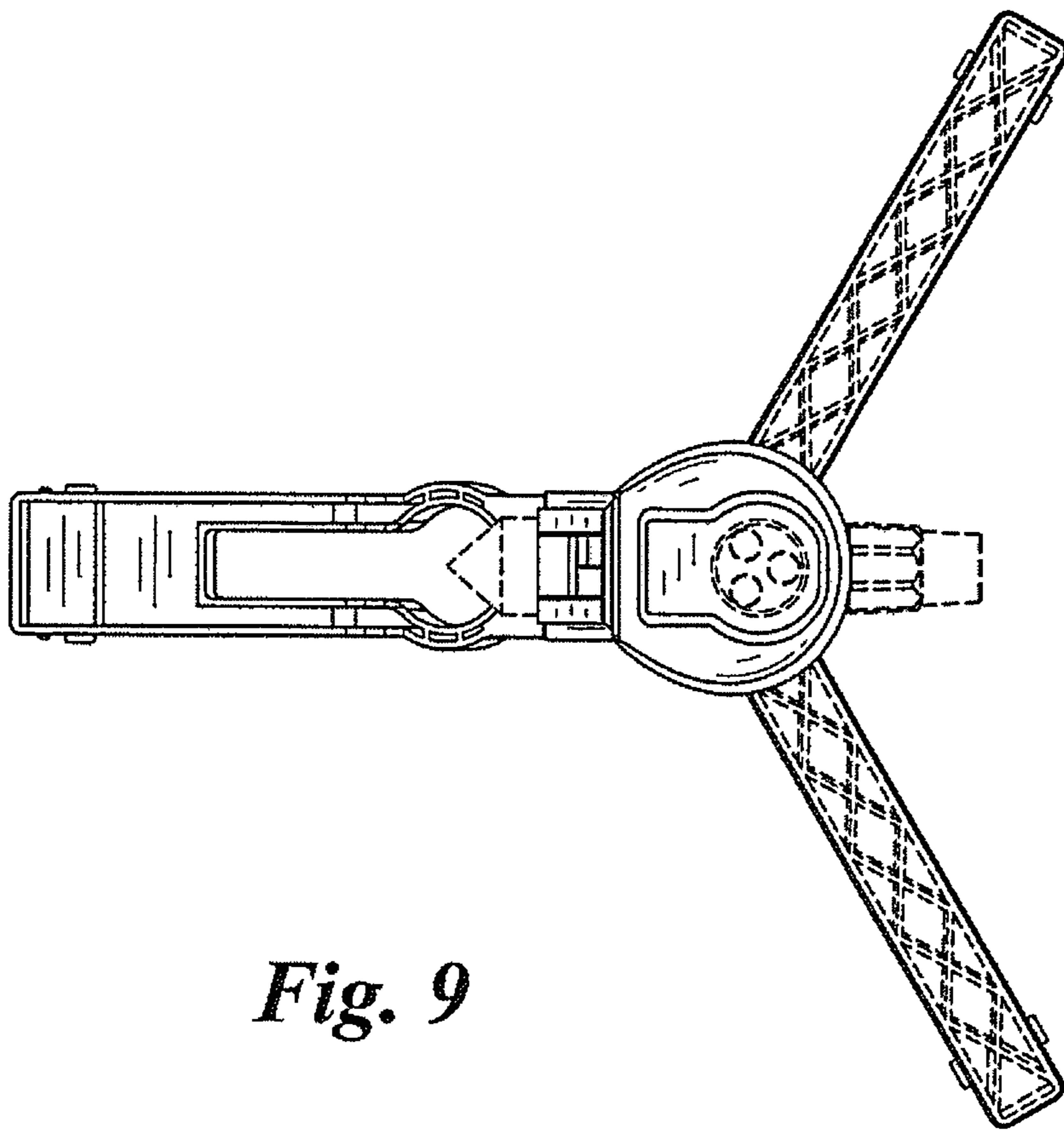
*Fig. 6*



*Fig. 7*

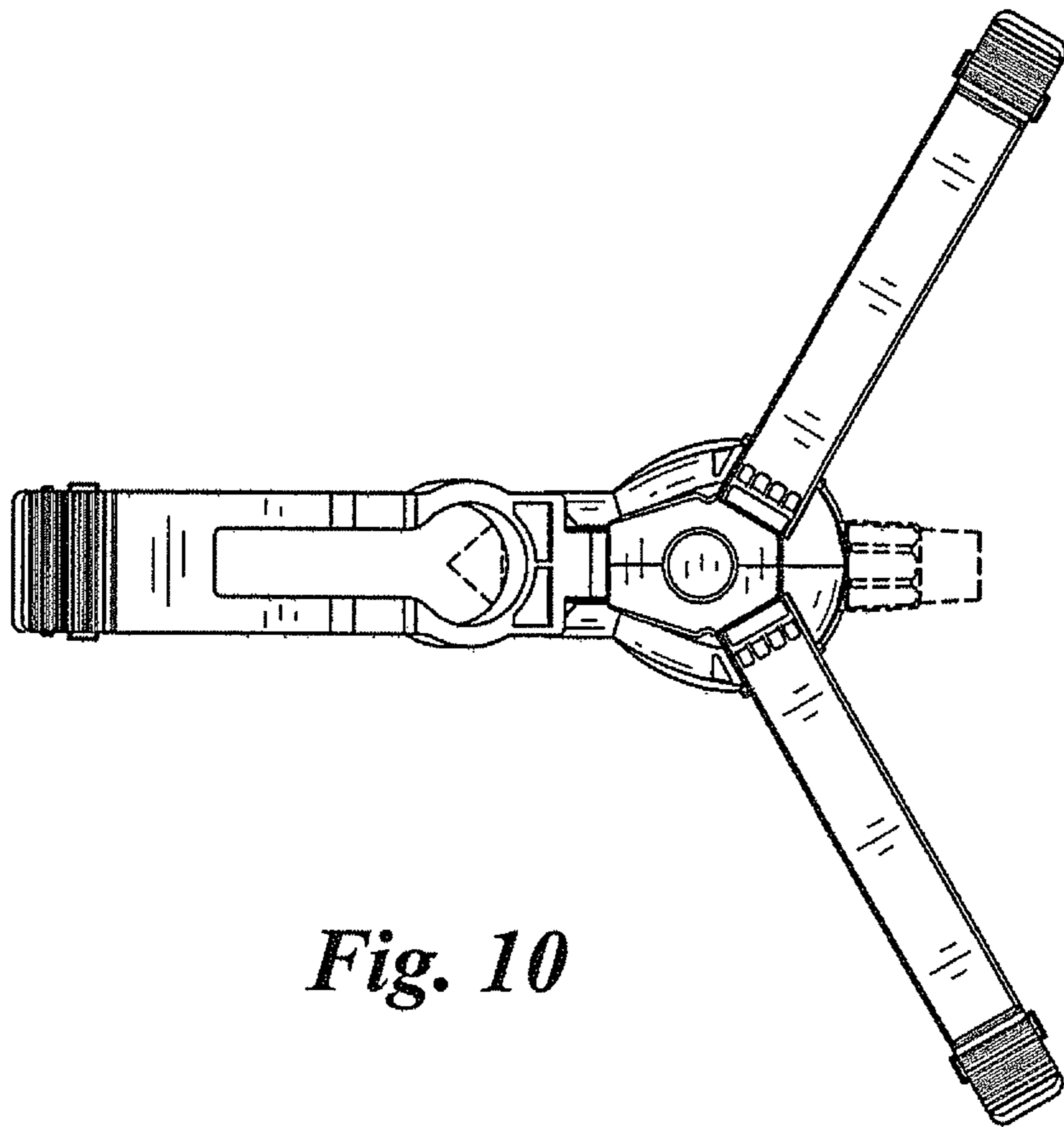


*Fig. 8*

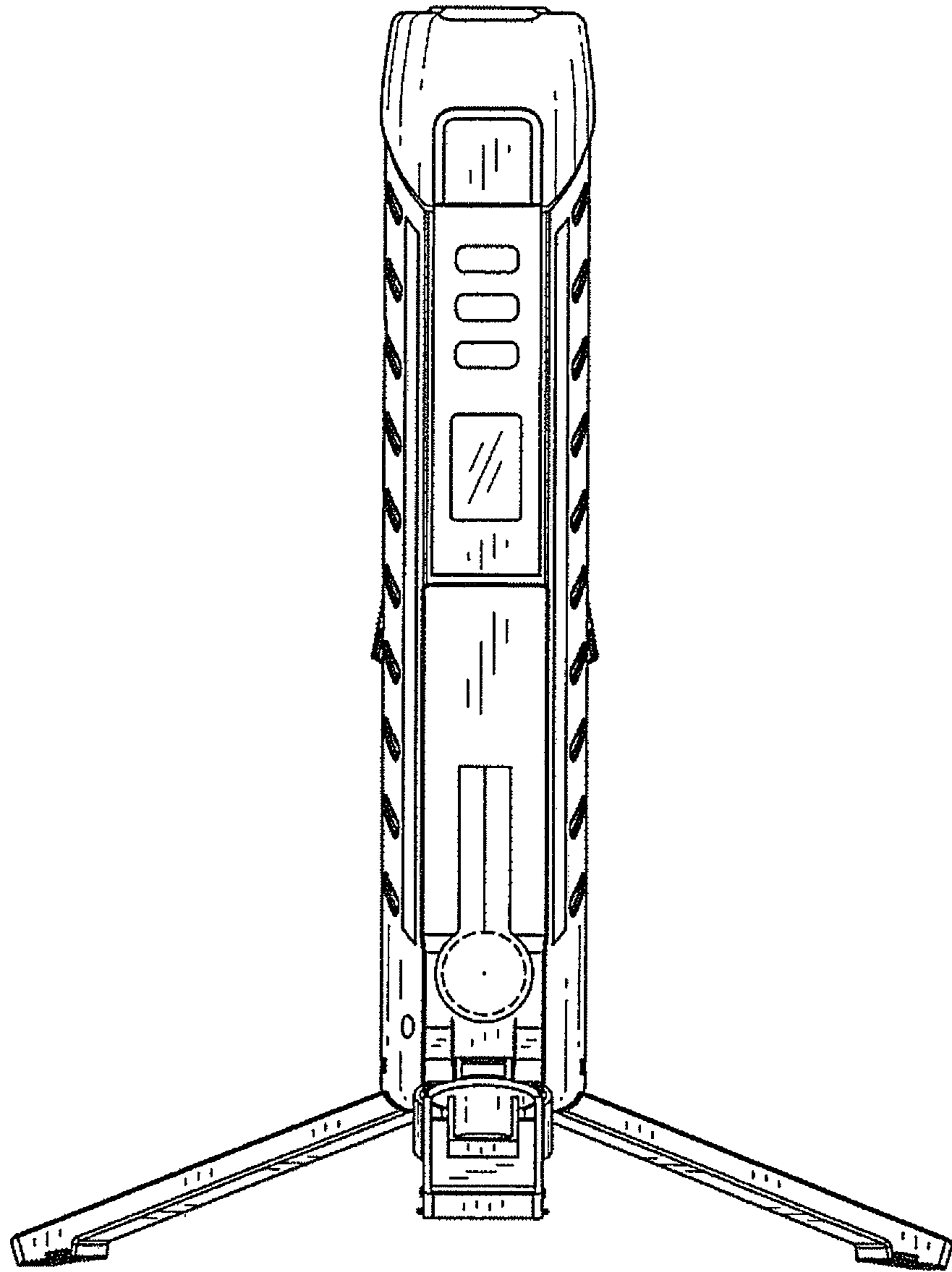


*Fig. 9*

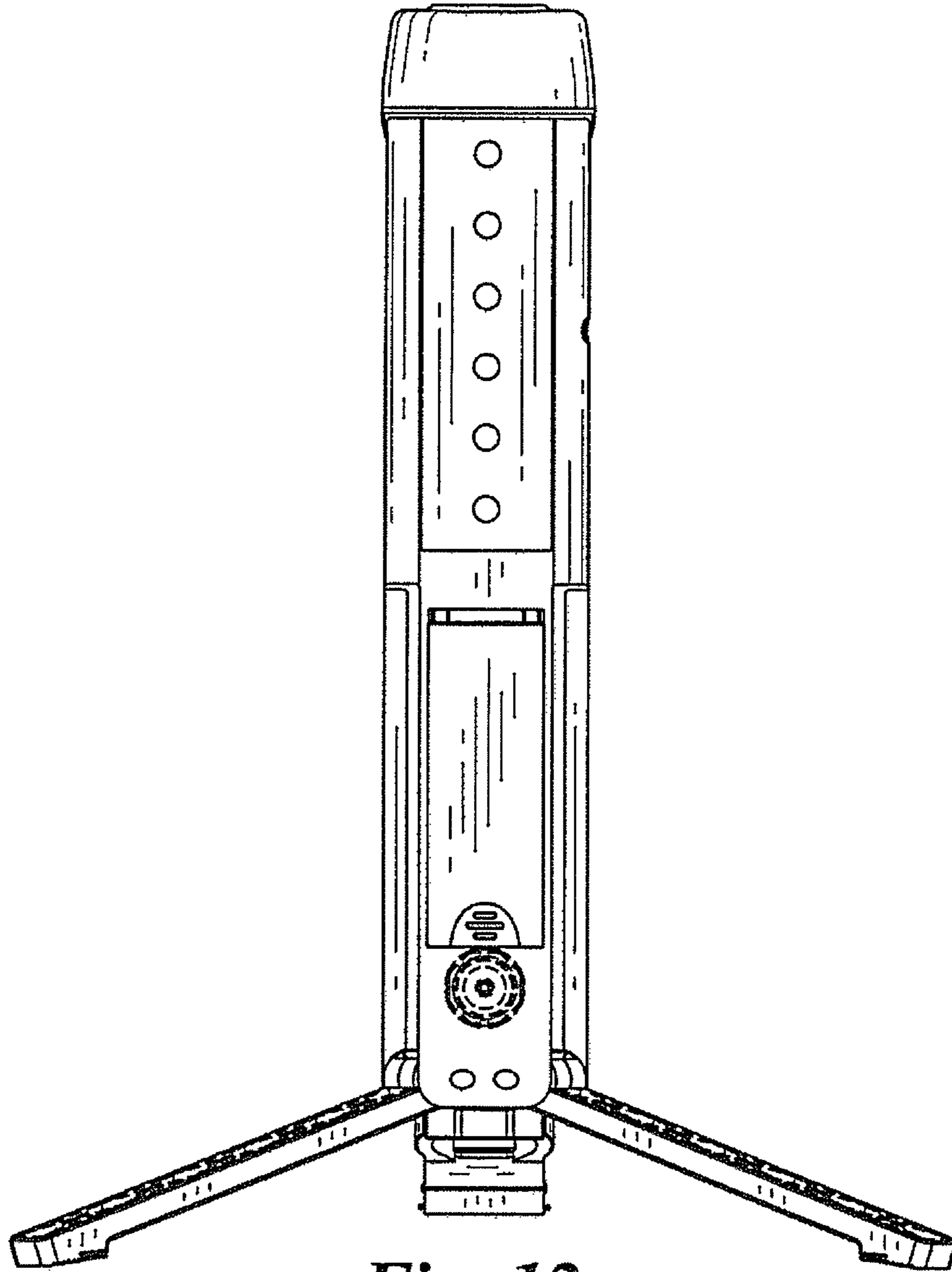




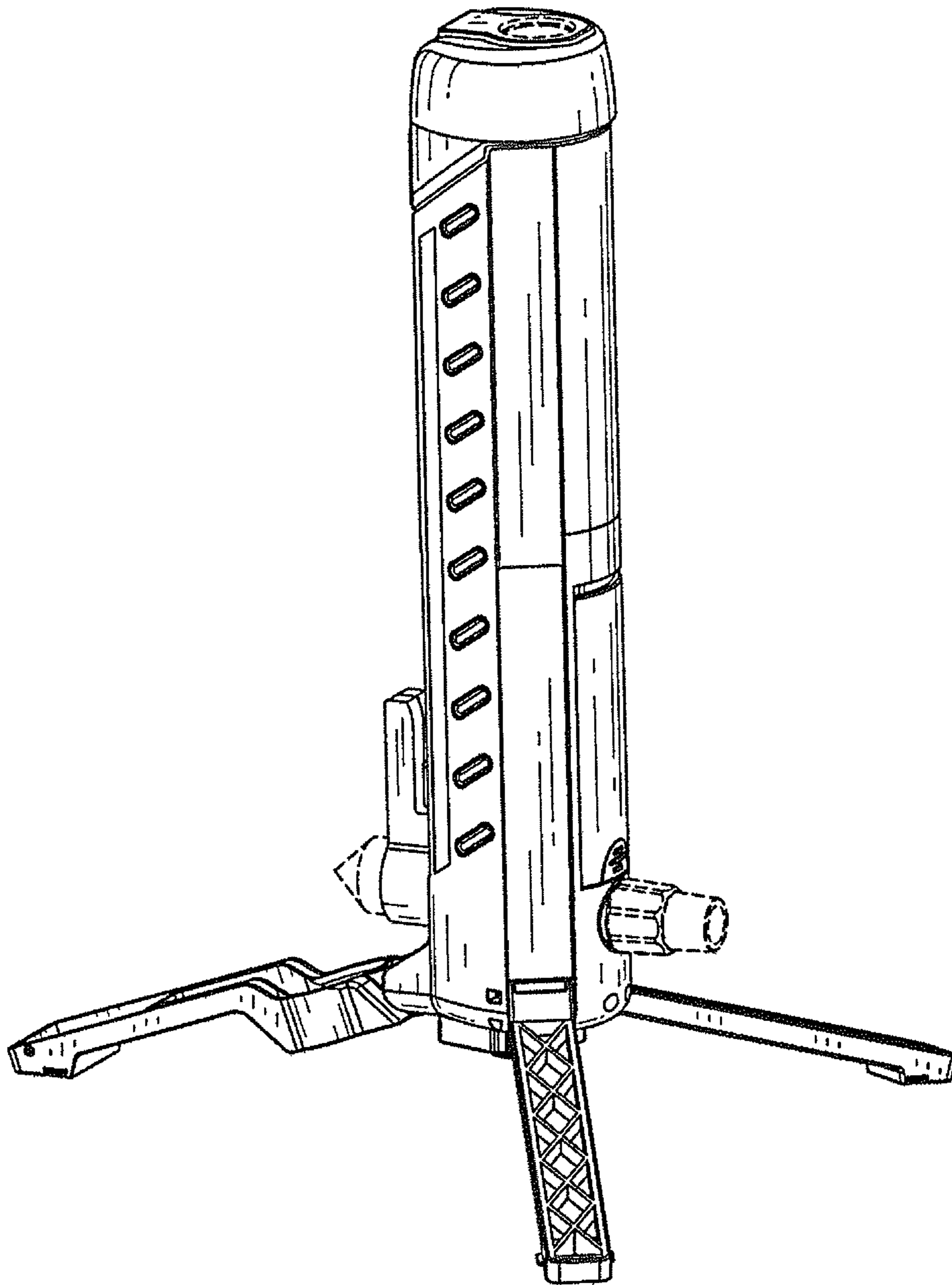
*Fig. 10*



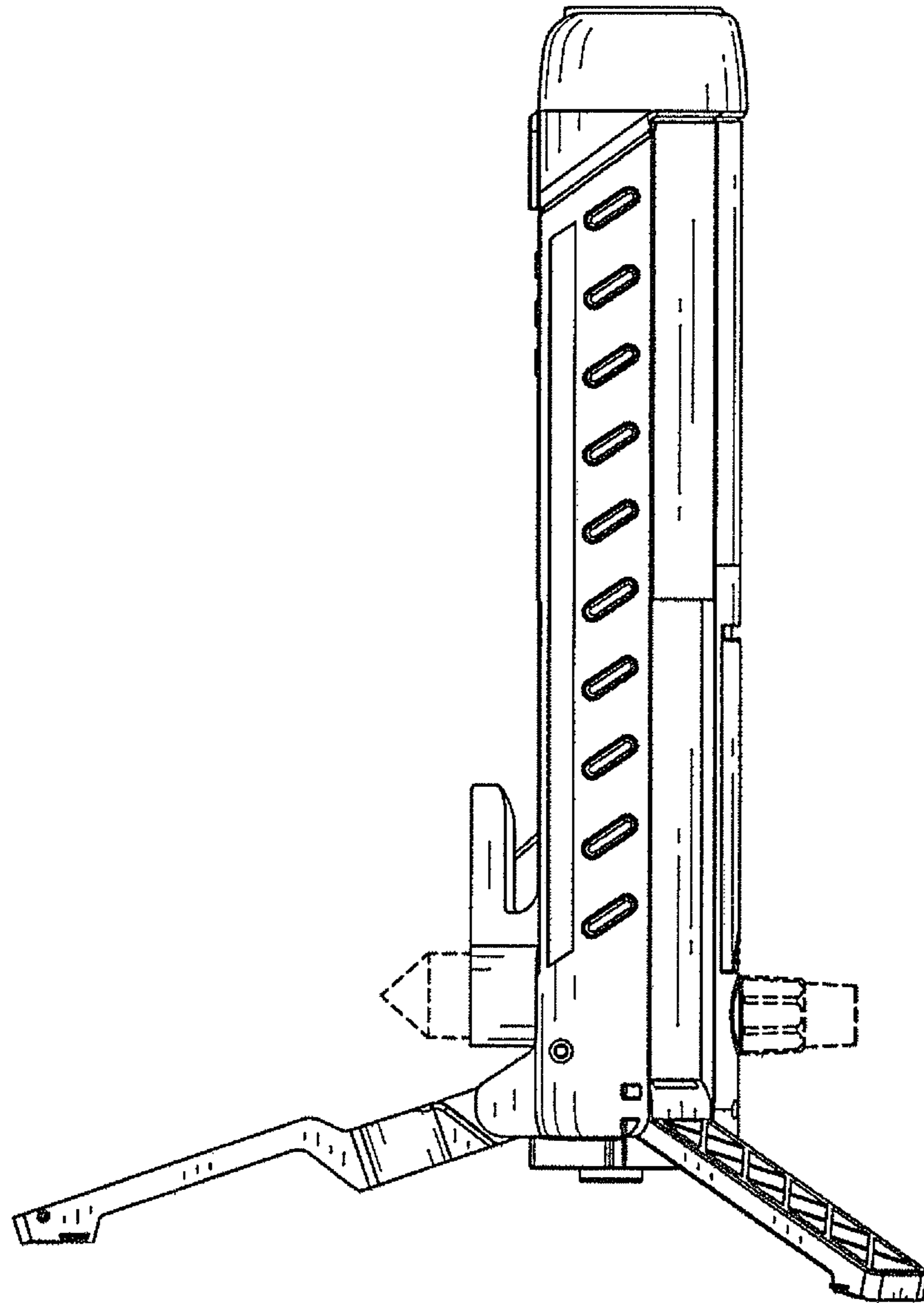
*Fig. 11*



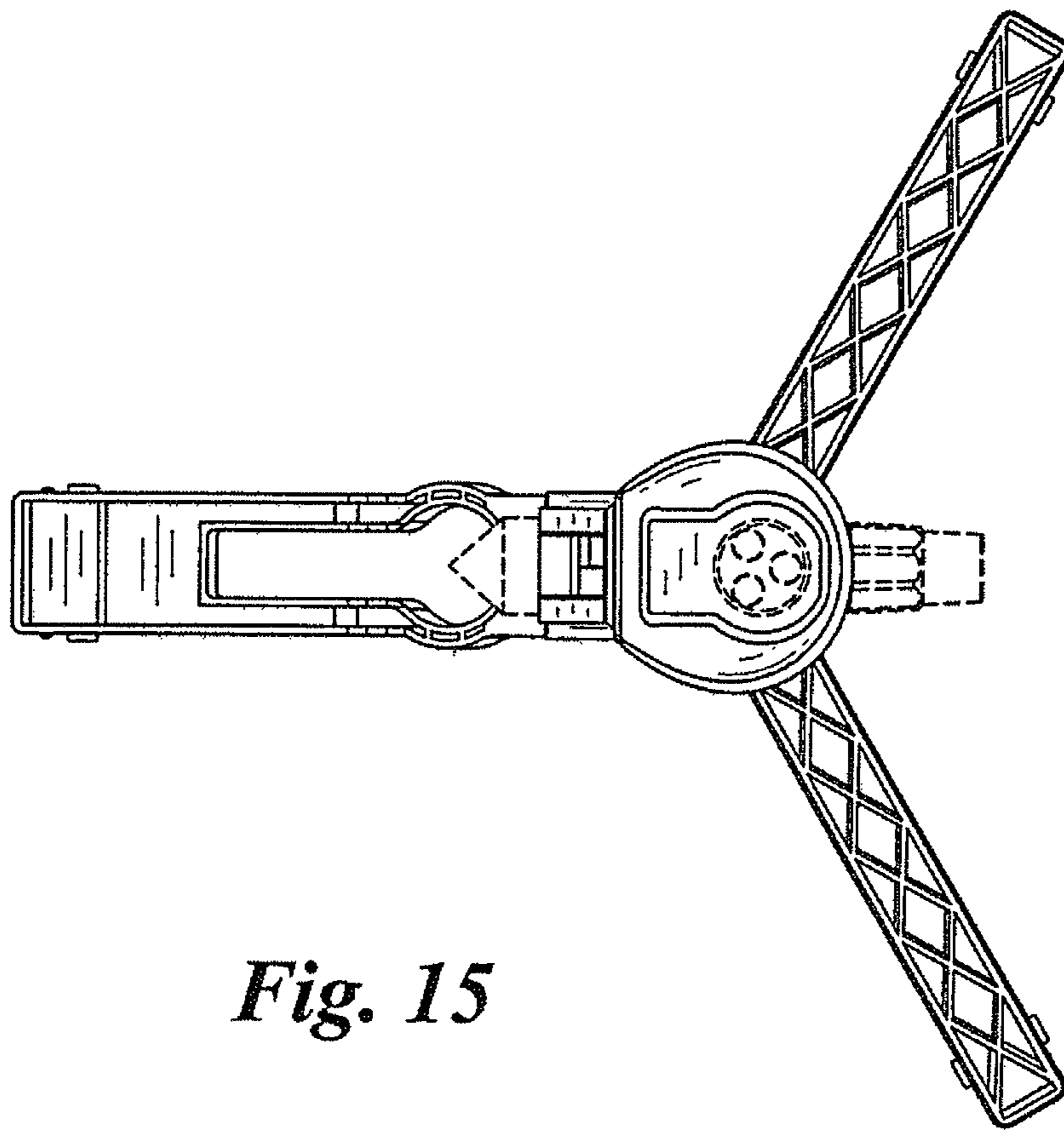
*Fig. 12*



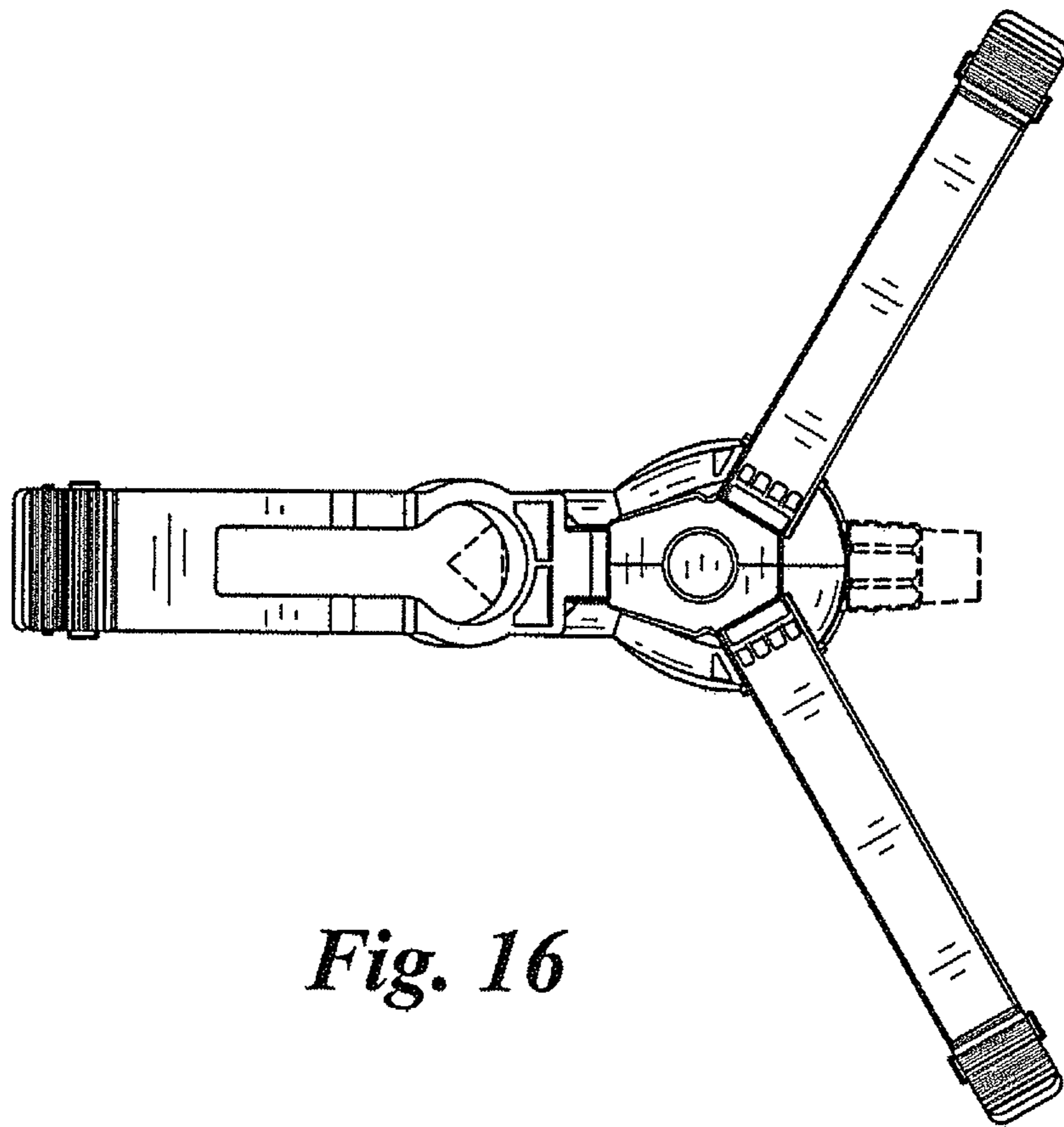
*Fig. 13*



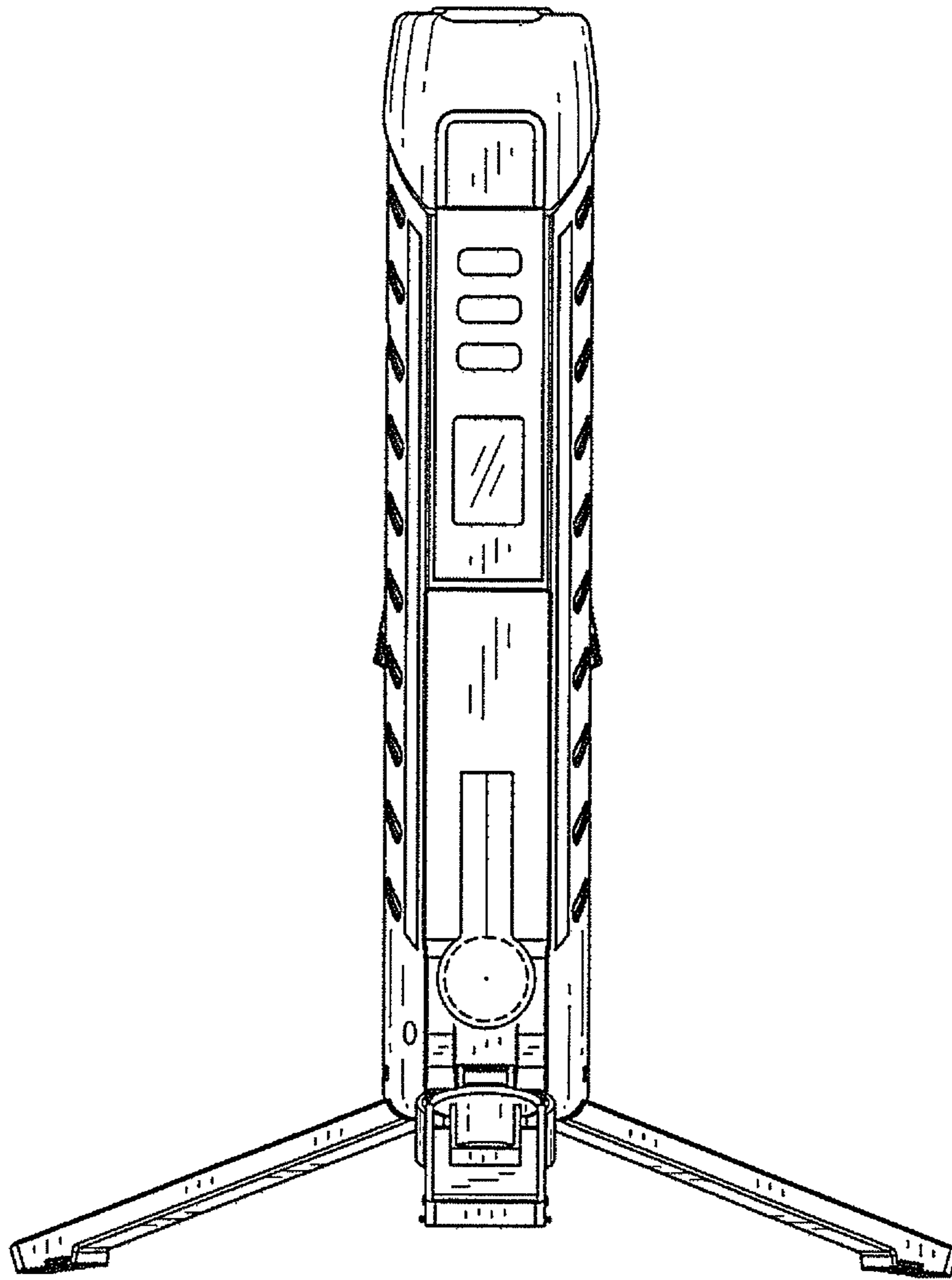
*Fig. 14*



*Fig. 15*

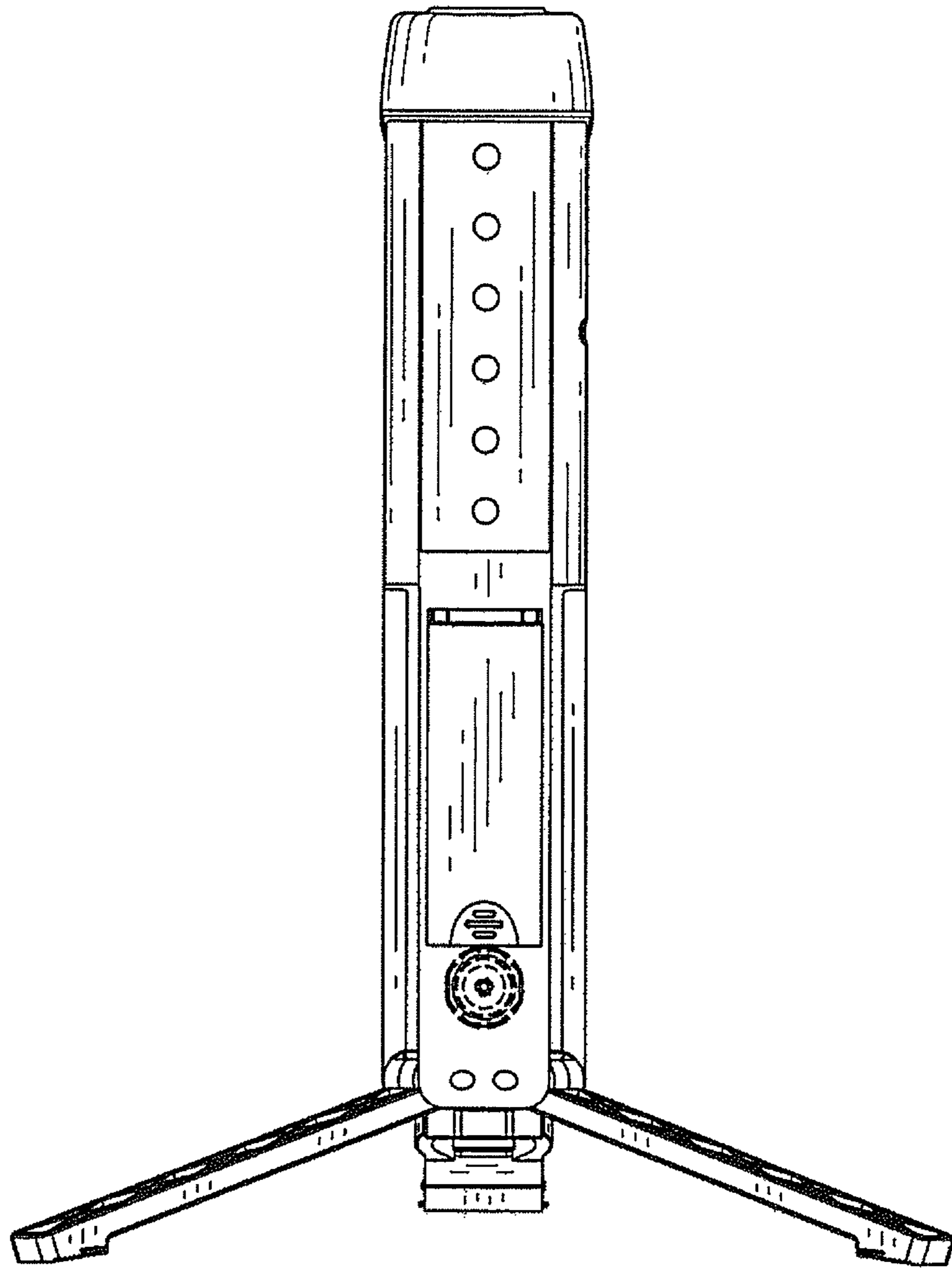


*Fig. 16*



*Fig. 17*





*Fig. 18*