



US00D705638S

(12) **United States Design Patent**
Aruga

(10) **Patent No.:** **US D705,638 S**

(45) **Date of Patent:** **** May 27, 2014**

- (54) **ASSIST HANDLE FOR AIRCRAFT**
- (71) Applicant: **Mitsubishi Aircraft Corporation,**
Nagoya (JP)
- (72) Inventor: **Hiroyasu Aruga,** Tokyo (JP)
- (73) Assignee: **Mitsubishi Aircraft Corporation,**
Nagoya-Shi (JP)
- (**) Term: **14 Years**
- (21) Appl. No.: **29/451,143**
- (22) Filed: **Mar. 28, 2013**

- (30) **Foreign Application Priority Data**
Jan. 22, 2013 (JP) 2013-000960
- (51) **LOC (10) Cl.** **08-06**
- (52) **U.S. Cl.**
CPC **B25G 1/04** (2013.01)
USPC **D8/300; D8/303**
- (58) **Field of Classification Search**
CPC B65G 1/04
USPC D8/300, 303, 94, 107, 315, 316, 317,
D8/318, 319, 320; 16/110.1, 412, 436;
4/576.1; D6/549
See application file for complete search history.

- (56) **References Cited**
U.S. PATENT DOCUMENTS
1,311,635 A * 7/1919 Baker 52/27
1,509,807 A * 9/1924 Gray 15/235.4
1,544,368 A * 6/1925 Brennan 15/235.4
1,652,018 A * 12/1927 Kubelka 16/436
2,151,182 A * 3/1939 Birdsall 16/444
D125,452 S * 2/1941 Marshall et al. D8/318
D175,751 S * 10/1955 Aleks D8/317
3,156,977 A * 11/1964 Logan 228/170
D199,839 S * 12/1964 Simpson D8/316

- 3,183,549 A * 5/1965 Hammesfahr 16/442
- 5,050,252 A * 9/1991 Cuttriss 4/576.1
- 5,303,451 A * 4/1994 Graviss et al. 16/412
- D370,617 S * 6/1996 Decursu et al. D8/316
- D380,956 S * 7/1997 Collins D8/316
- 5,690,237 A * 11/1997 Marzec 211/105.1
- D388,272 S * 12/1997 Moore D6/549

(Continued)

Primary Examiner — Paula Greene
(74) *Attorney, Agent, or Firm* — Birch, Stewart, Kolasch & Birch, LLP

(57) **CLAIM**
The ornamental design for an assist handle for aircraft, as shown and described.

DESCRIPTION

FIG. 1 is a perspective view of an assist handle for aircraft. FIG. 2 is a perspective view thereof. FIG. 3 is a front elevation view thereof. A rear elevation view is identical to the front elevation view. FIG. 4 is a top plan view thereof. FIG. 5 is a bottom plan view thereof. FIG. 6 is a left side elevation view thereof. A right side elevation view is identical to the left side elevation view. FIG. 7 is a cross-sectional view taken along the line 7-7 in FIG. 6. FIG. 8 is a cross-sectional view taken along the line 8-8 in FIG. 3. FIG. 9 is a referential view showing use thereof on the lavatory wall. FIG. 10 is a referential view showing use thereof around the door; and, FIG. 11 is a referential view showing use thereof in the cockpit. The portions shown in broken lines are for the purpose of showing environmental structure only and form no part of the claimed design.

1 Claim, 11 Drawing Sheets

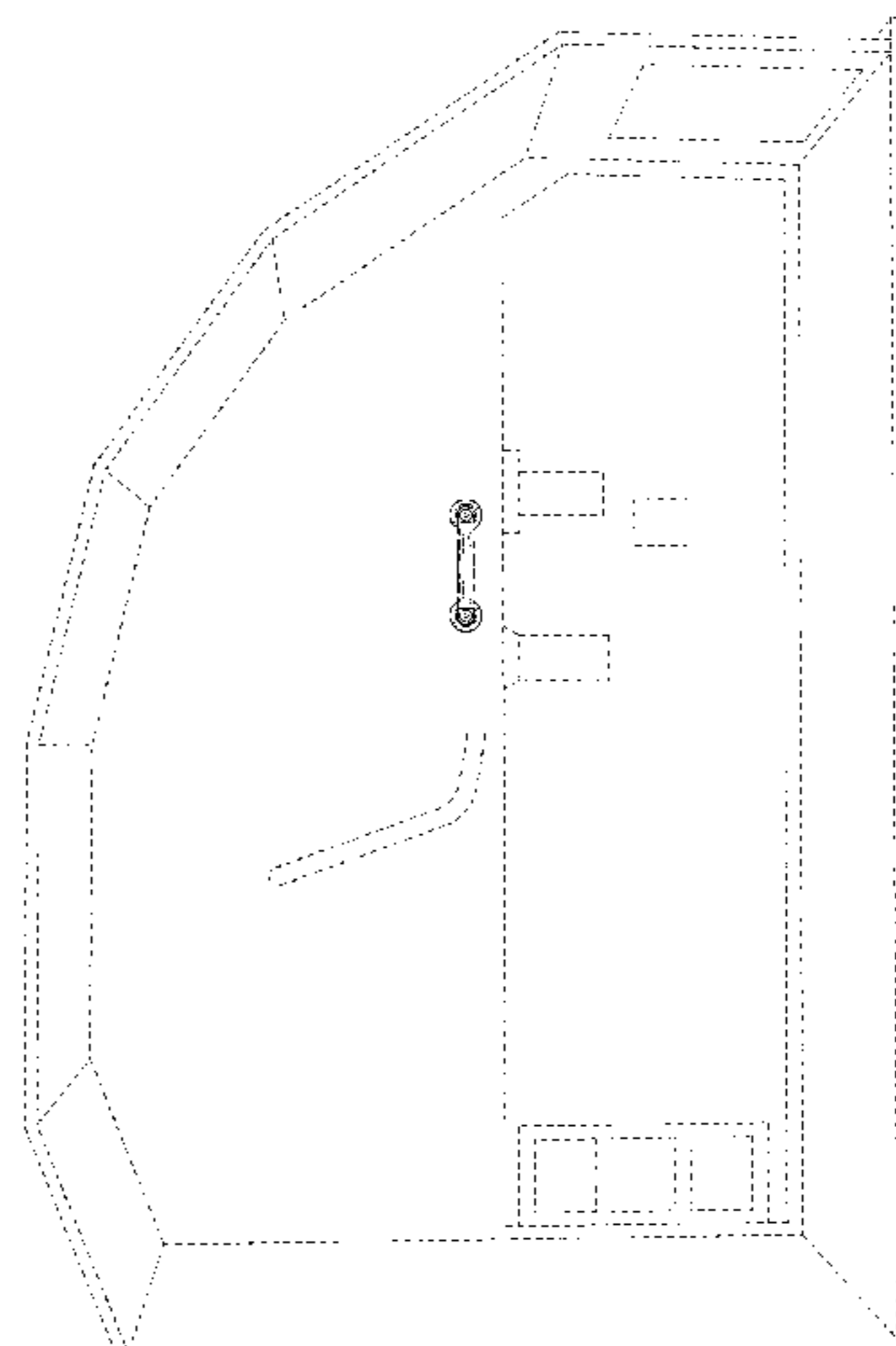
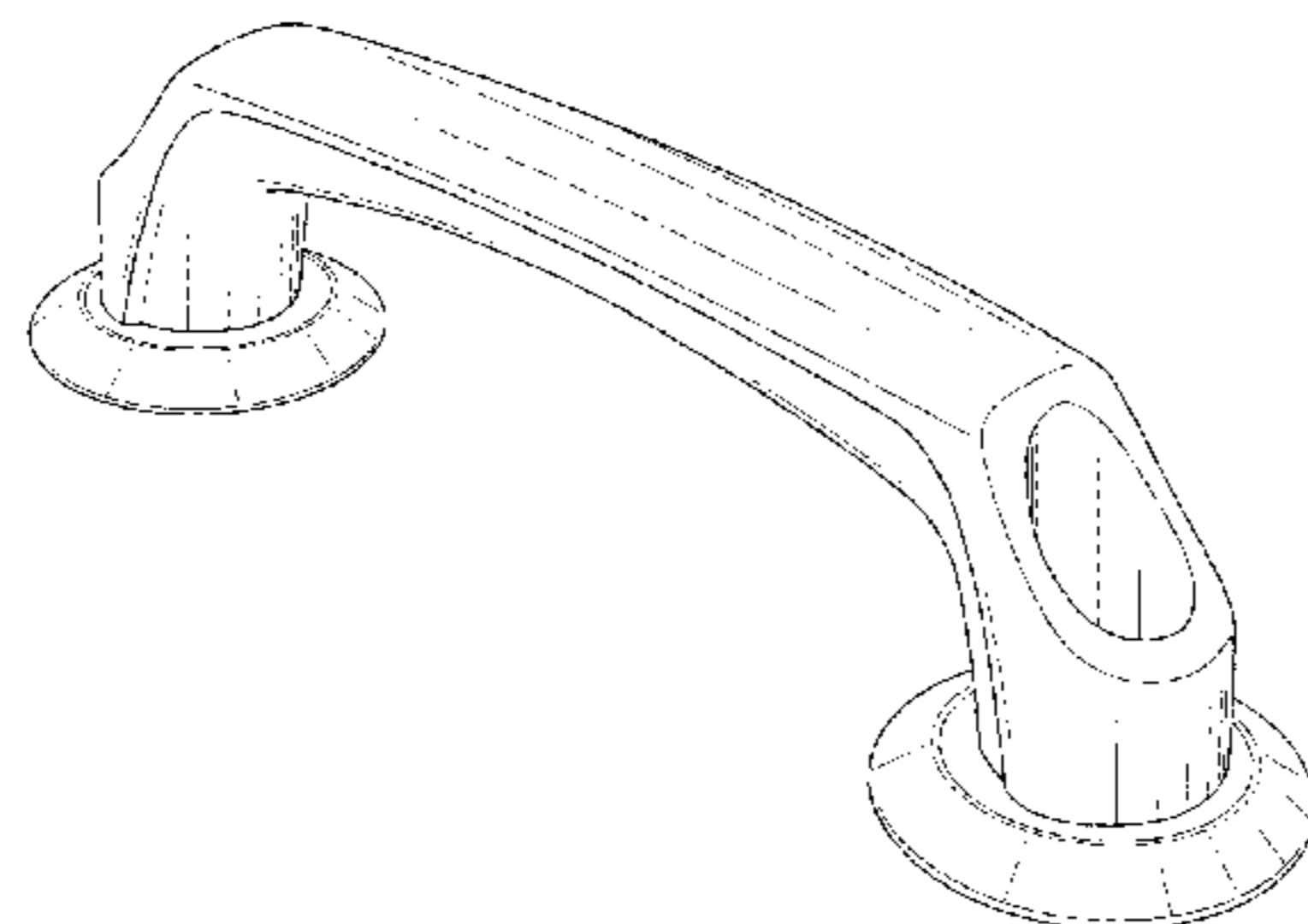

(56)

References Cited

U.S. PATENT DOCUMENTS

D389,721 S * 1/1998 Zemel D8/300
D399,406 S * 10/1998 Decursu et al. D8/317
5,920,957 A * 7/1999 Wagner 16/408
D426,134 S * 6/2000 Pytlewski D8/107
D449,215 S * 10/2001 Bertani D8/316
D516,406 S * 3/2006 Brammer et al. D8/300

D531,876 S * 11/2006 Jimenez D8/94
D562,104 S * 2/2008 Griffis D8/300
D568,142 S * 5/2008 Zhang et al. D8/320
D573,868 S * 7/2008 Ricereto D8/315
D579,534 S * 10/2008 Genord et al. D23/304
D582,750 S * 12/2008 Heidrich et al. D8/316
D602,138 S * 10/2009 Gilbert et al. D23/304
D664,022 S * 7/2012 Gilbert D8/316
8,533,912 B2 * 9/2013 Tran 16/110.1

* cited by examiner

FIG. 1

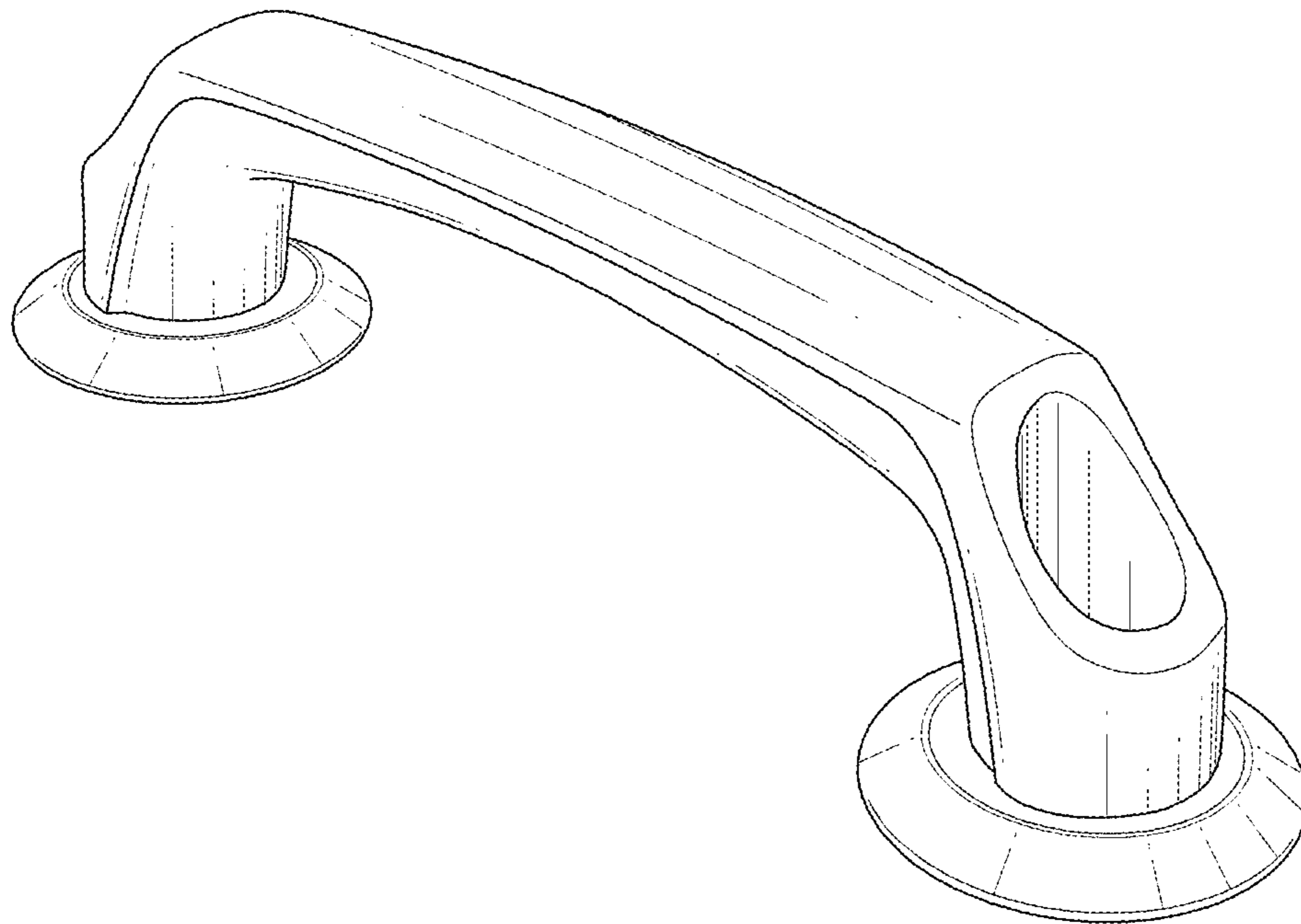

FIG. 2

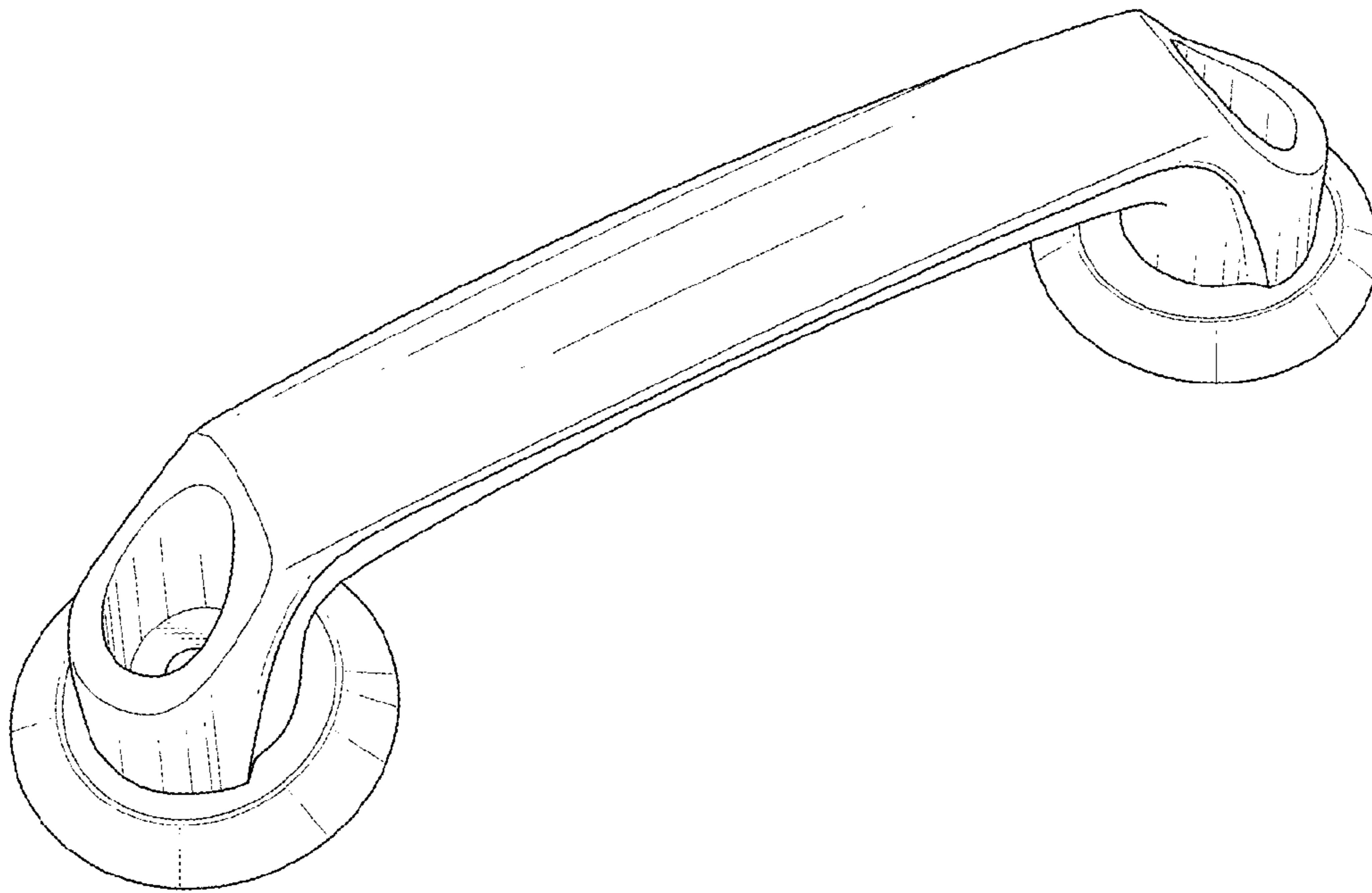

FIG. 3

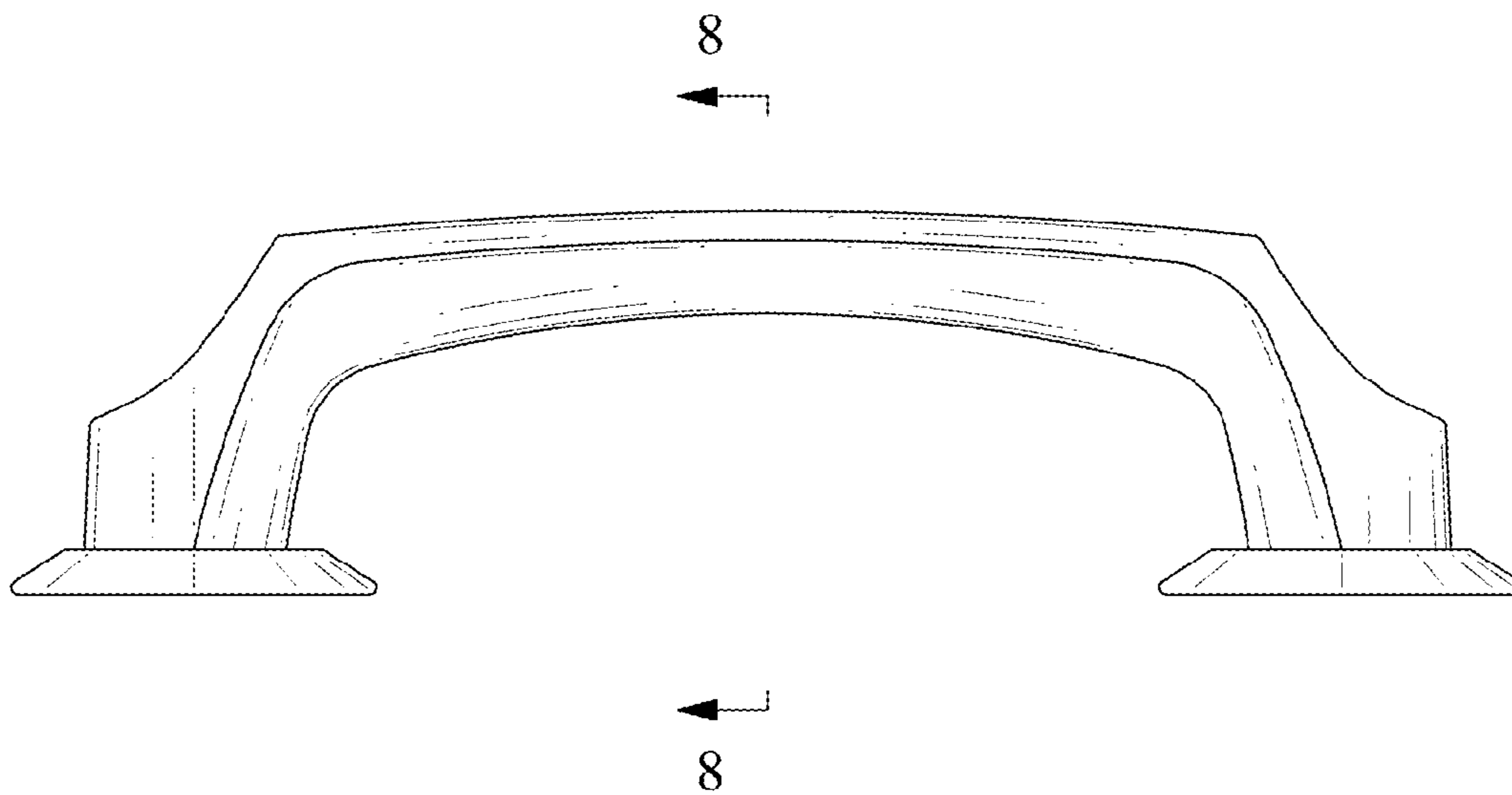

FIG. 4

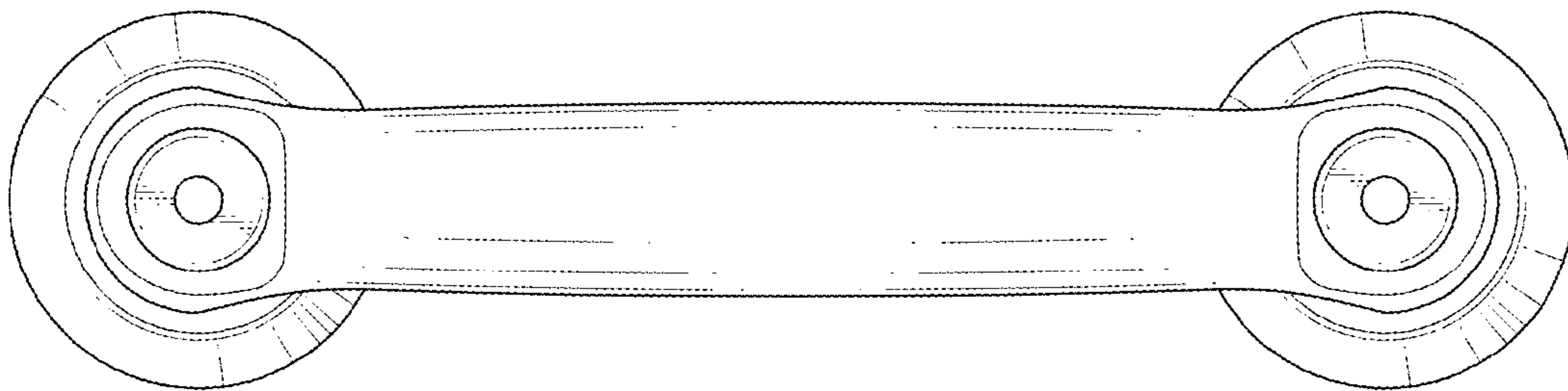

FIG. 5

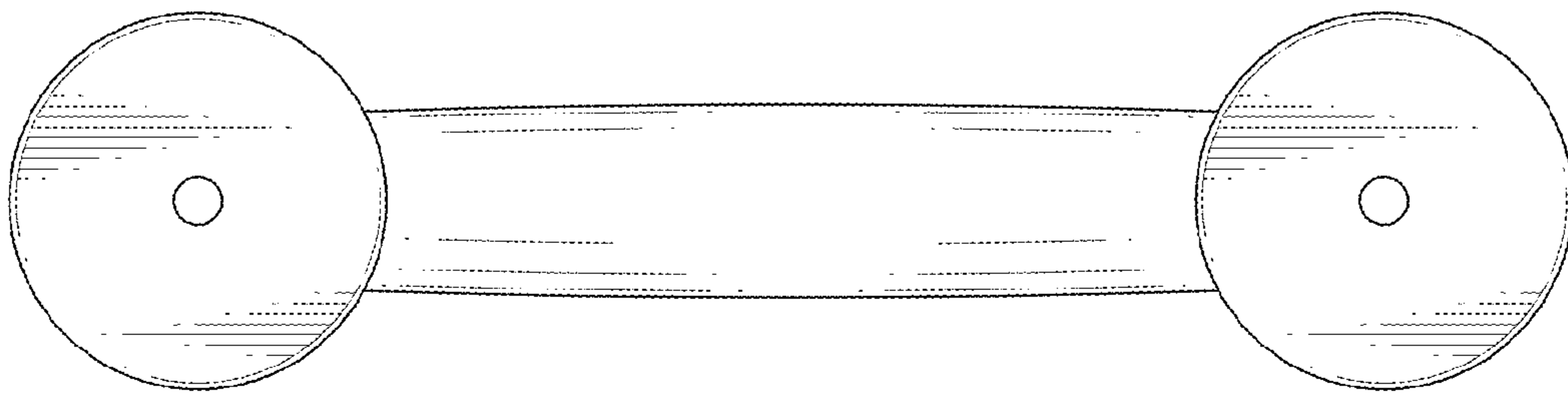

FIG. 6

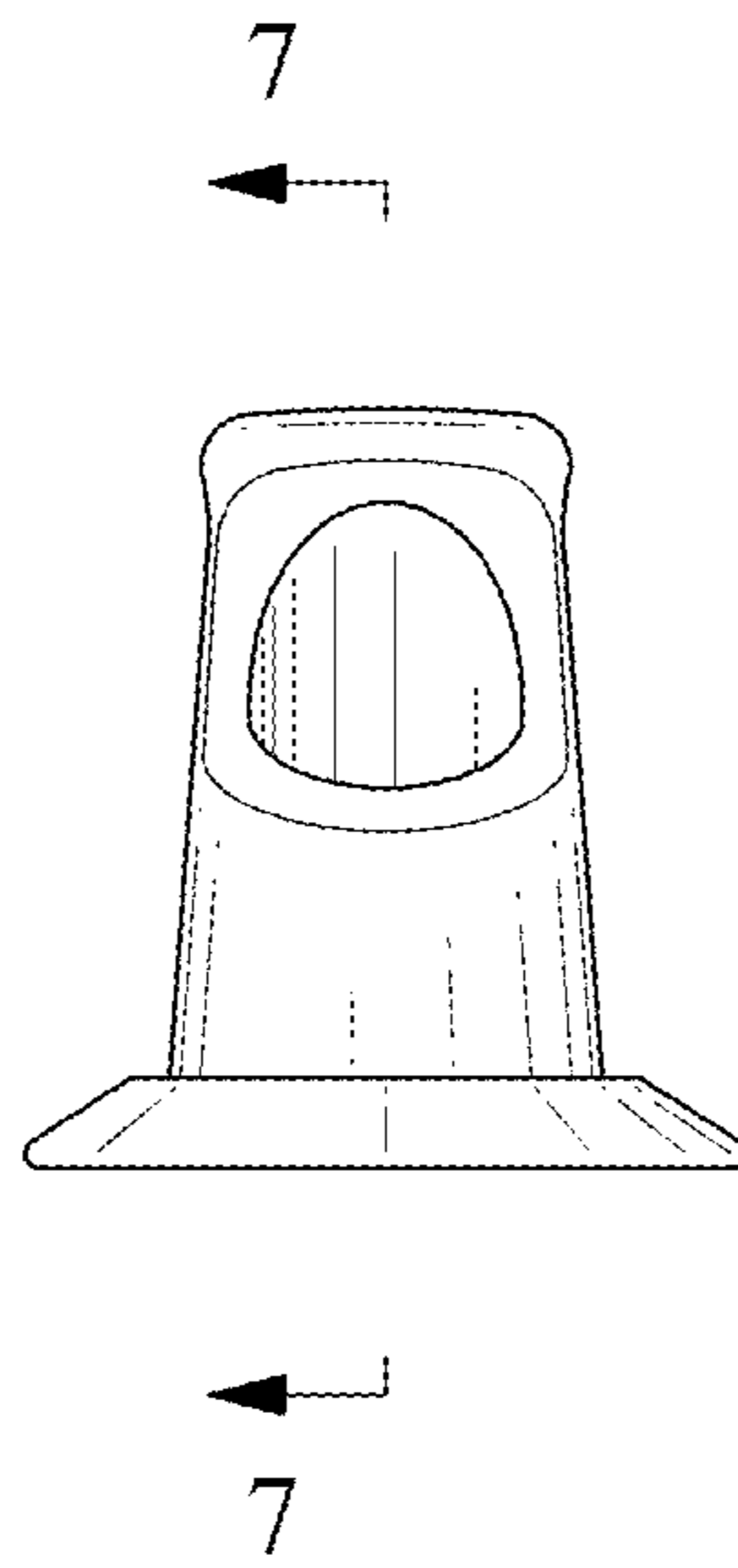

FIG. 7

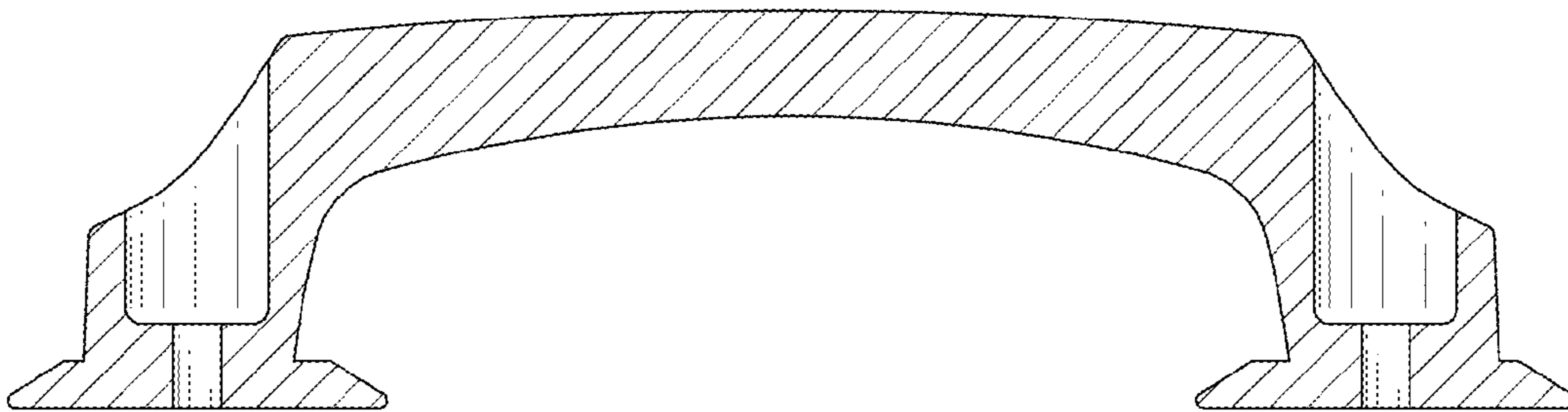

FIG. 8

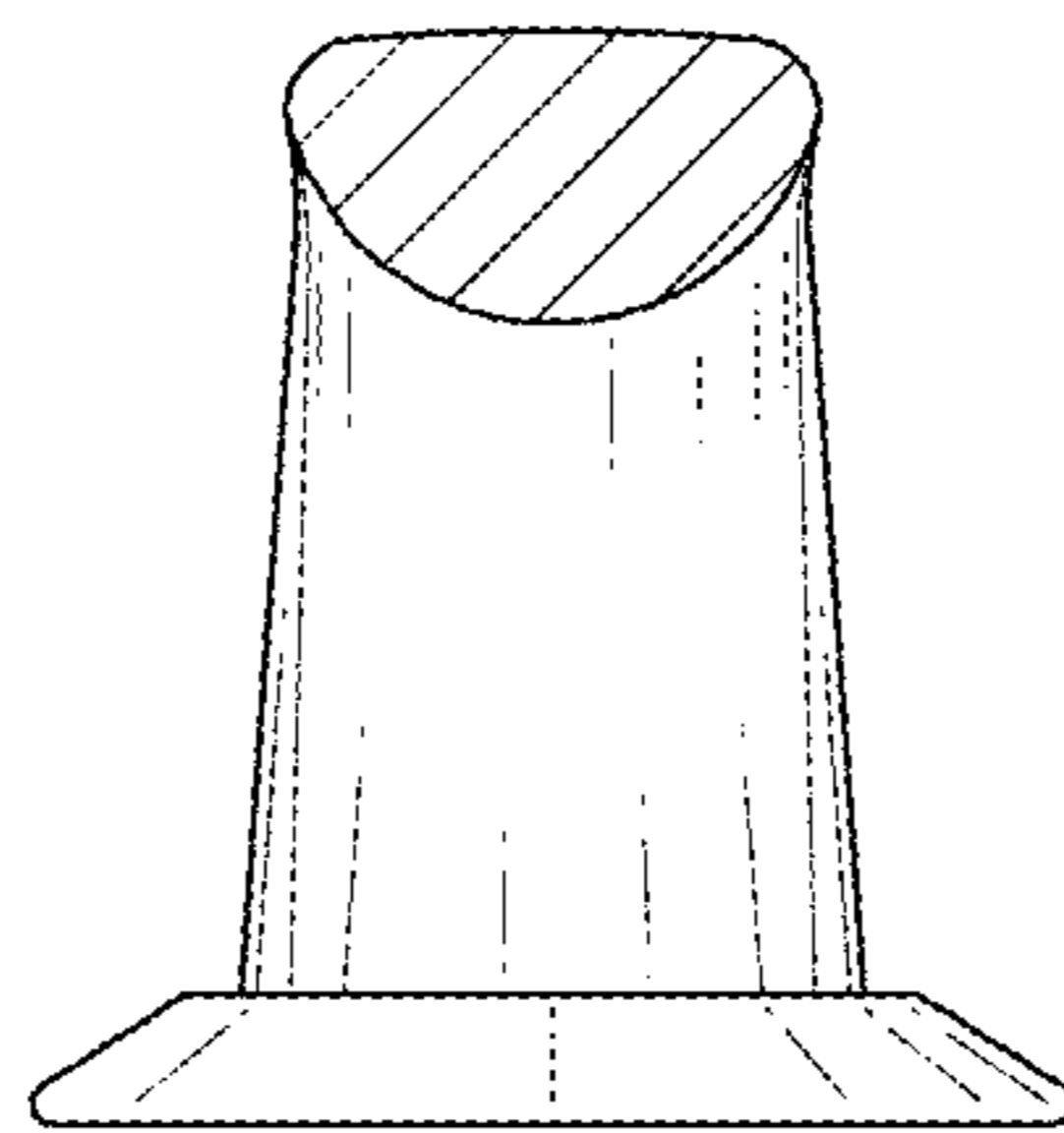

FIG. 9

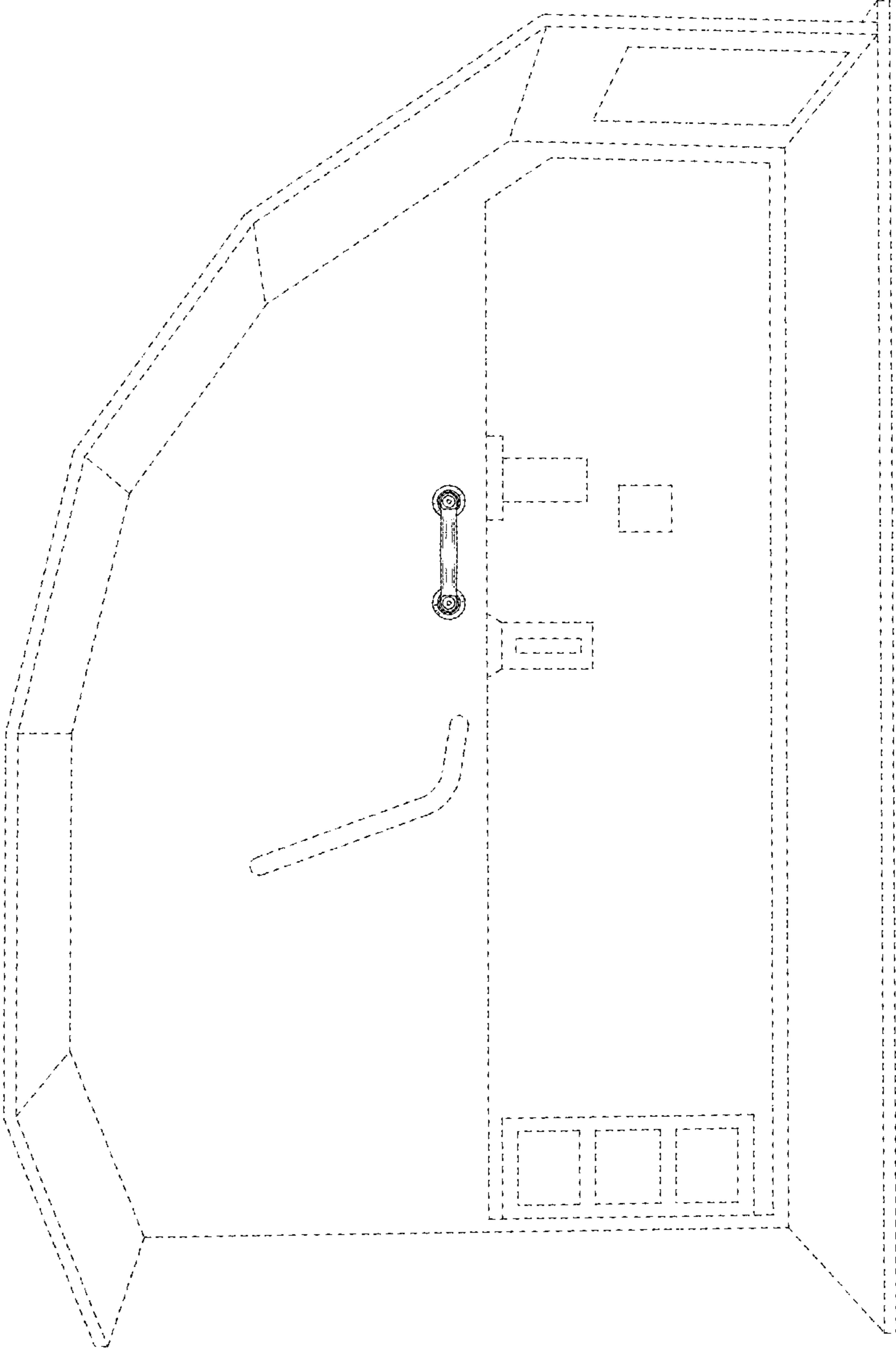

FIG. 10

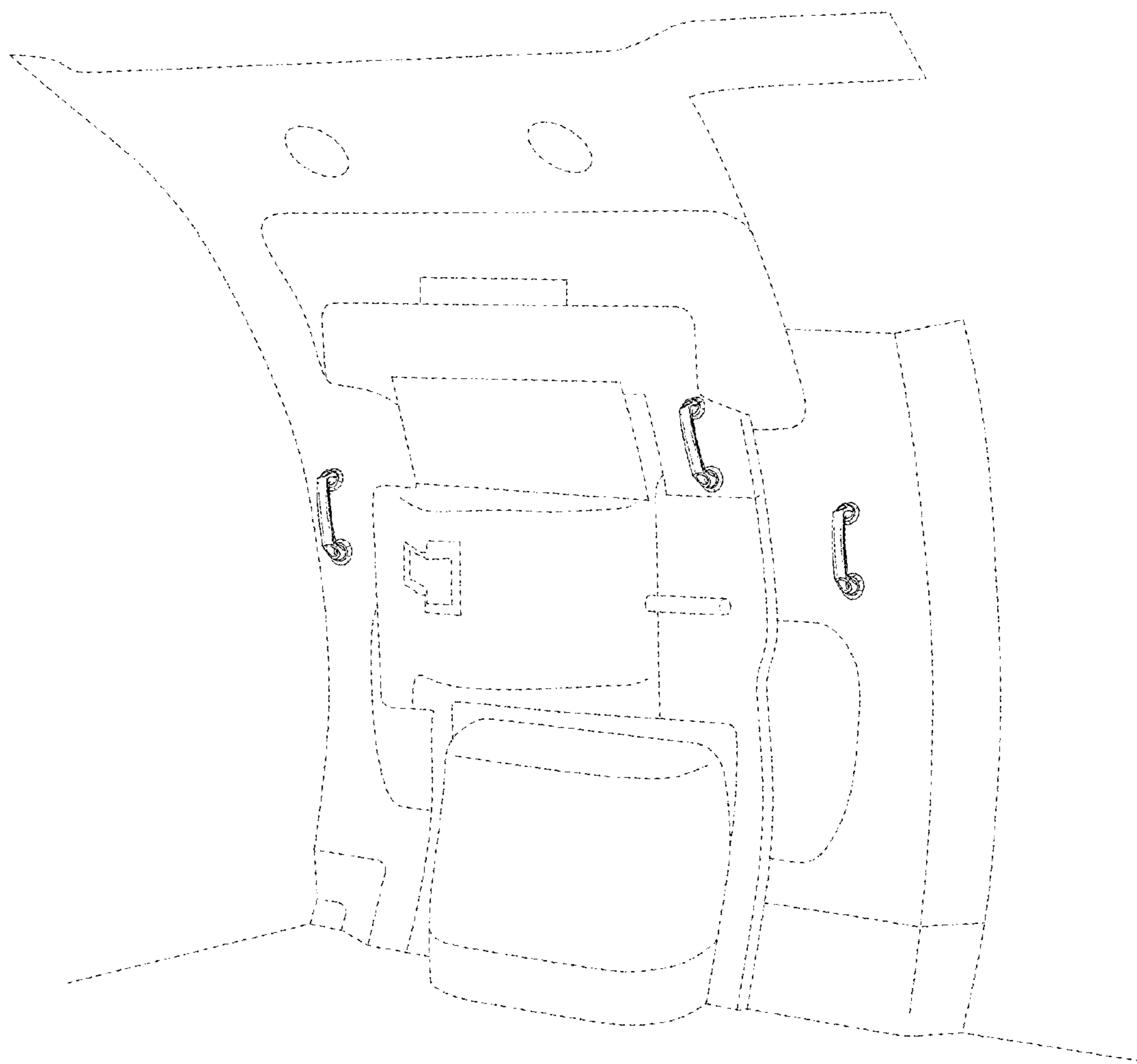

FIG. 11

