



US00D705408S

(12) **United States Design Patent**  
**Patterson et al.**

(10) **Patent No.:** **US D705,408 S**

(45) **Date of Patent:** **\*\* May 20, 2014**

(54) **HIGH VELOCITY TRUCK COOLER**

(75) Inventors: **Vance M. Patterson**, Morganton, NC (US); **Matthew Patterson**, Columbia, SC (US); **Mark E. Moore**, Ridgeway, SC (US)

(73) Assignee: **Patterson Fan Company**, Blythewood, SC (US)

(\*\*) Term: **14 Years**

(21) Appl. No.: **29/405,741**

(22) Filed: **Nov. 4, 2011**

(51) **LOC (10) Cl.** ..... **12-16**

(52) **U.S. Cl.**  
USPC ..... **D23/325**

(58) **Field of Classification Search**  
USPC ..... D23/325, 373, 324, 314, 351, 333;  
62/239, 244, 61, 279; D15/79, 81, 89,  
D15/91

See application file for complete search history.

(56) **References Cited**

**U.S. PATENT DOCUMENTS**

D130,076 S *	10/1941	Vondenbosh	.....	D23/325
D252,468 S *	7/1979	Seipp	.....	D23/325
D283,437 S *	4/1986	Neimy et al.	.....	D23/325
D290,747 S *	7/1987	Tigner et al.	.....	D23/325
D311,244 S *	10/1990	Allard et al.	.....	D23/325
5,220,808 A *	6/1993	Mayer	.....	62/244
D363,980 S *	11/1995	Roach	.....	D23/325
5,588,301 A *	12/1996	Deroche, Sr.	.....	62/61
D424,184 S *	5/2000	Chang-Kwon	.....	D23/325
6,698,220 B2 *	3/2004	Yoneno et al.	.....	62/184

D541,917 S *	5/2007	Pfeiffer	.....	D23/325
D578,628 S *	10/2008	Yoo et al.	.....	D23/333
D579,536 S *	10/2008	Oh et al.	.....	D23/351
D589,131 S *	3/2009	DeLucia	.....	D23/325
D613,383 S *	4/2010	Crosnier et al.	.....	D23/325
D625,799 S *	10/2010	Salisbury et al.	.....	D23/370
8,181,476 B2 *	5/2012	Khan et al.	.....	62/244
D687,135 S *	7/2013	Kampf et al.	.....	D23/324

\* cited by examiner

*Primary Examiner* — Katrina A Betton

(74) *Attorney, Agent, or Firm* — Nelson Mullins Riley & Scarborough LLP

(57) **CLAIM**

The ornamental design for a high velocity truck cooler, as shown and described.

**DESCRIPTION**

FIG. 1 is a perspective view of a high velocity truck cooler in accordance with an embodiment of the present invention; FIG. 2 is a front elevation view of the high velocity truck cooler of FIG. 1; FIG. 3 is a rear elevation view of the high velocity truck cooler of FIG. 1; FIG. 4 is a left side elevation view of the high velocity truck cooler of FIG. 1; FIG. 5 is a right side elevation view of the high velocity truck cooler of FIG. 1; FIG. 6 is a top plan view of the high velocity truck cooler of FIG. 1; and, FIG. 7 is a bottom plan view of the high velocity truck cooler of FIG. 1.

The broken lines shown in the accompanying drawings are for illustrative purposes only and form no part of the claim.

**1 Claim, 7 Drawing Sheets**

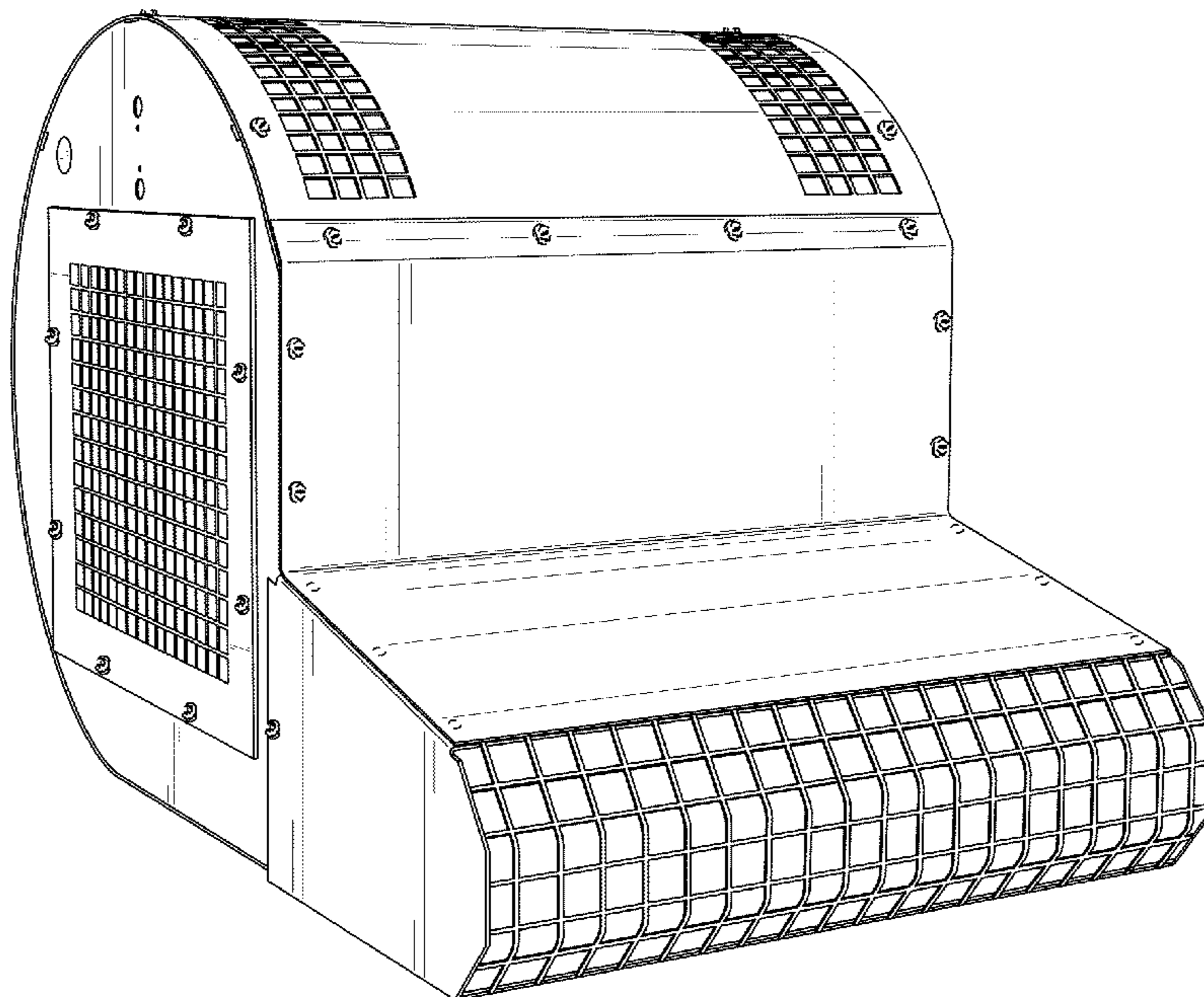

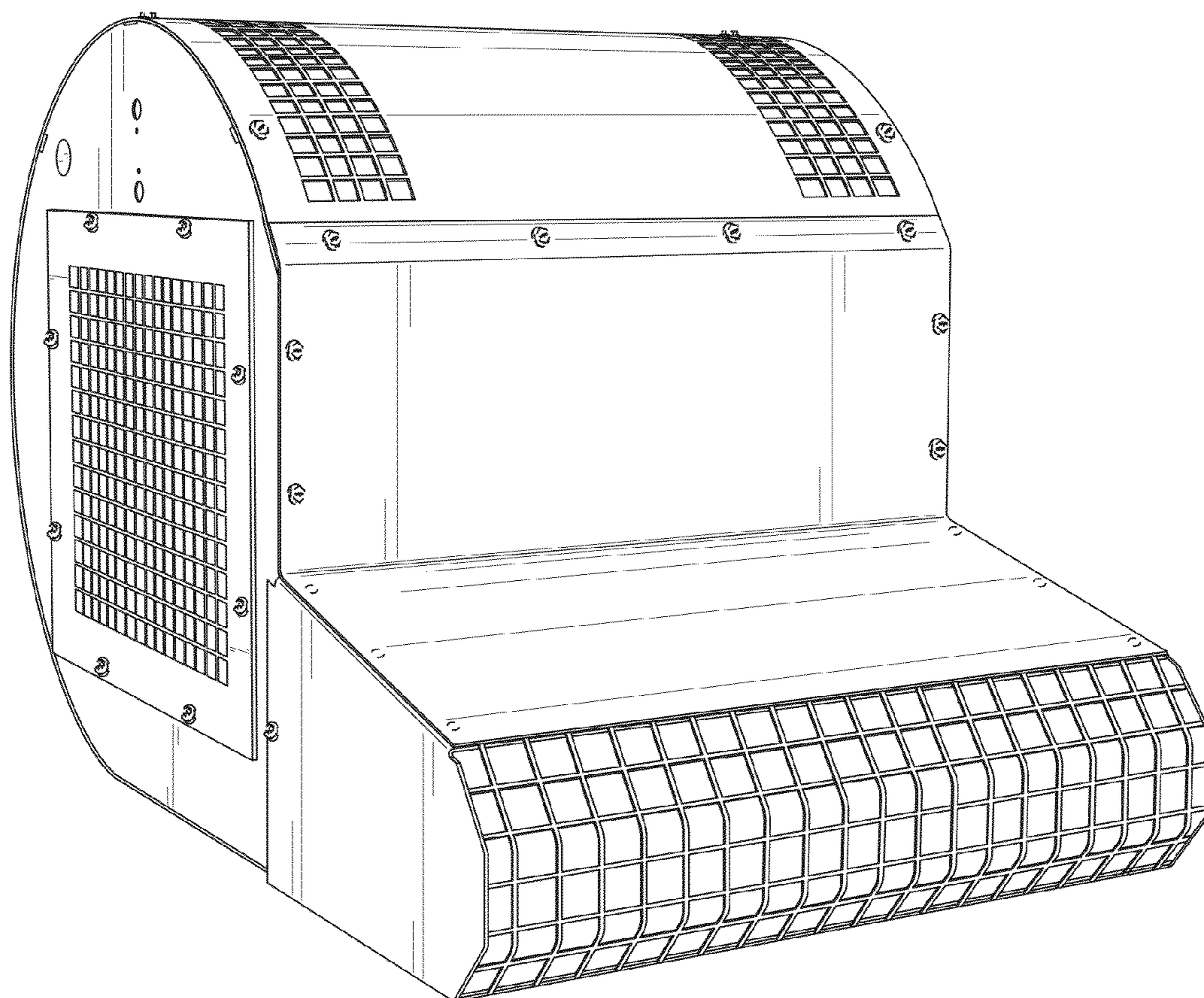

FIG. 1

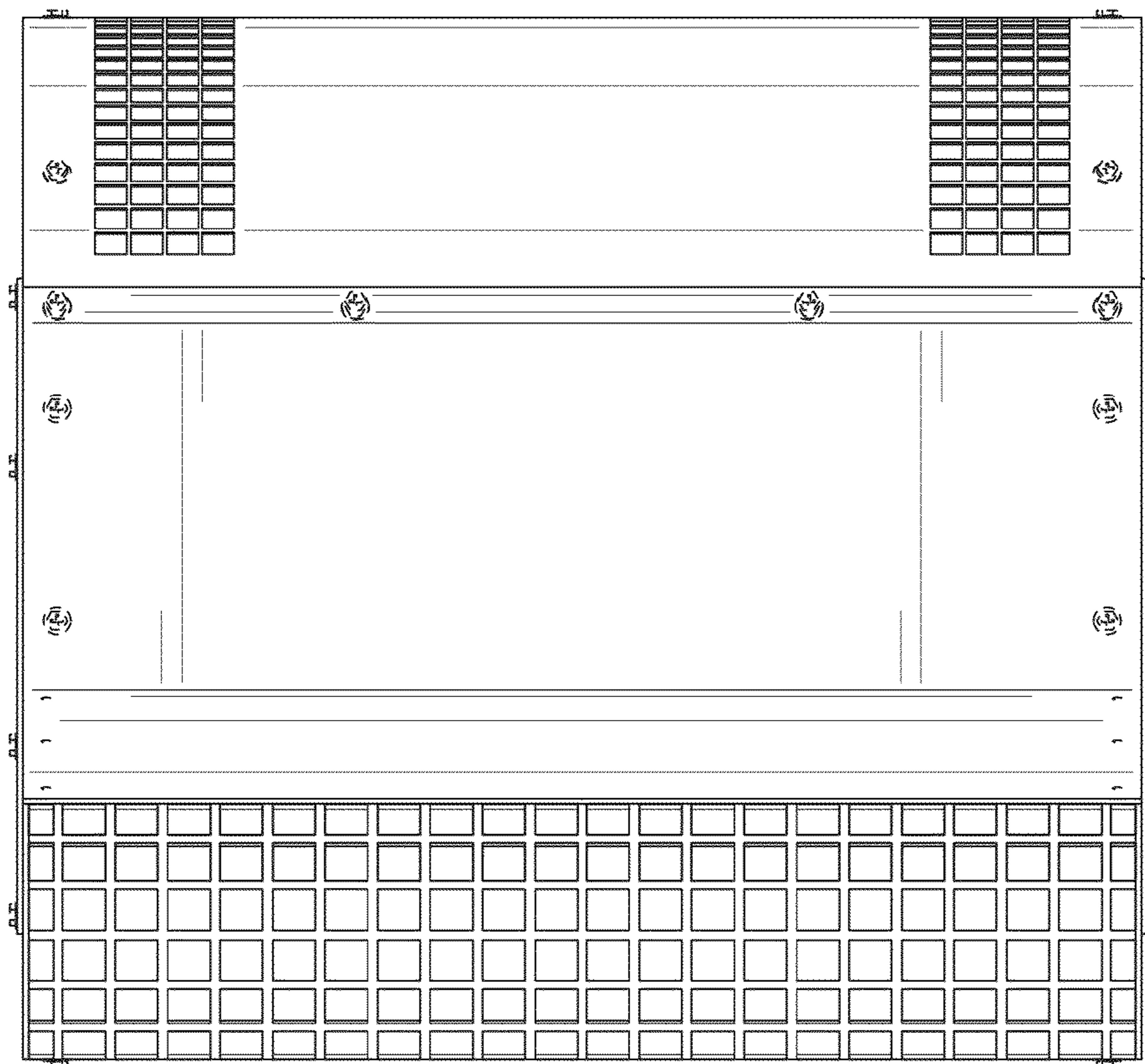

FIG. 2

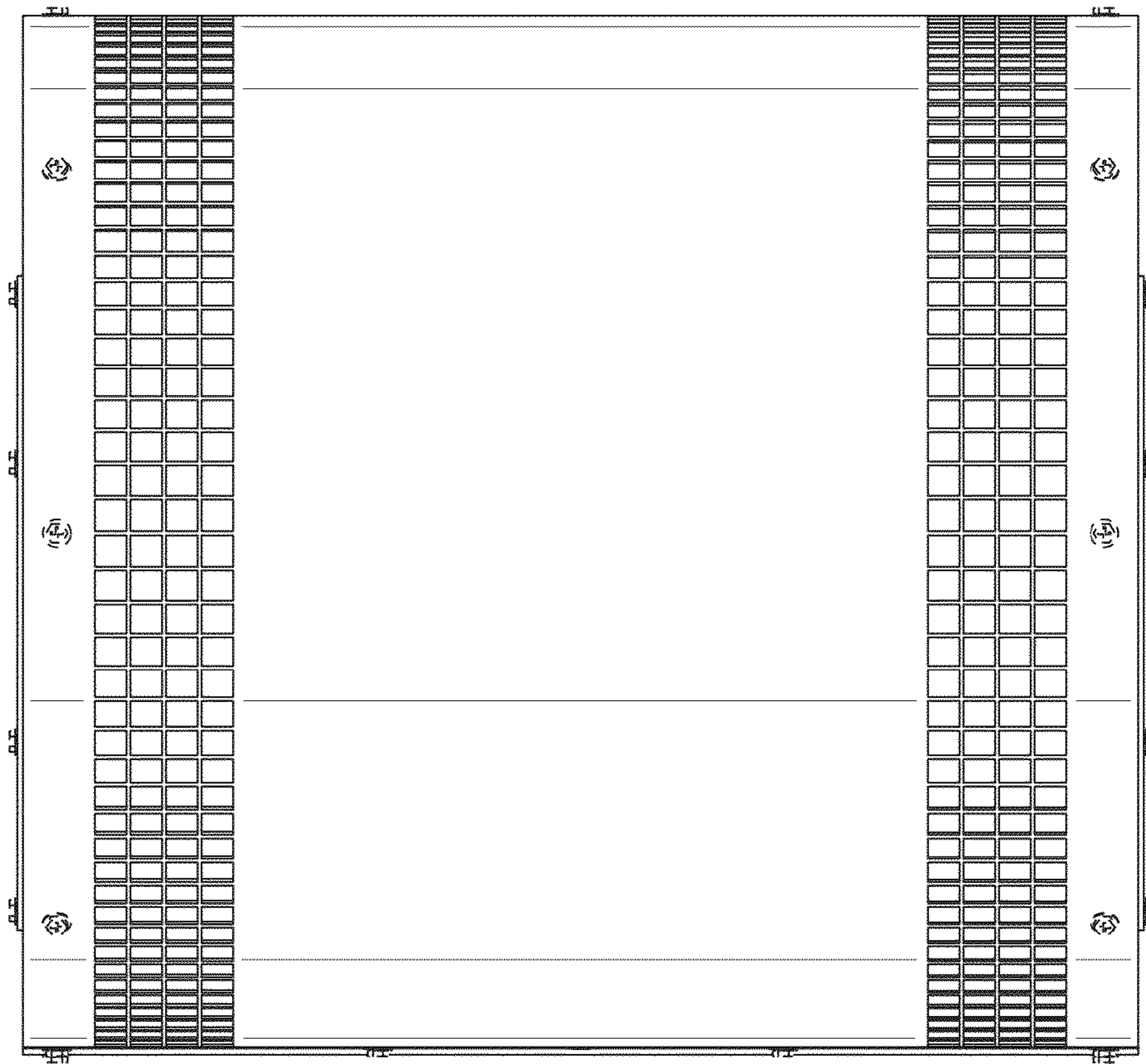

FIG. 3

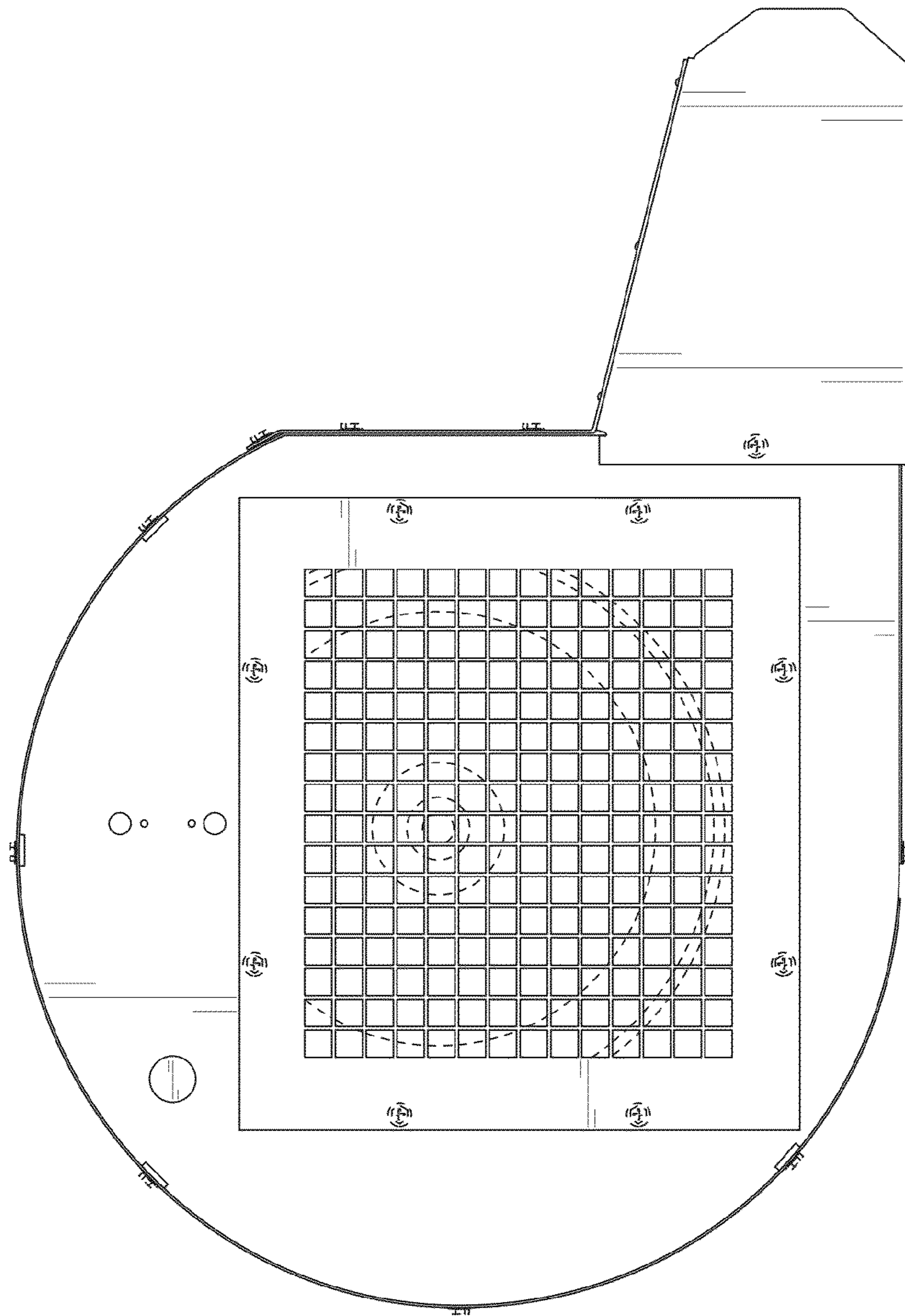

FIG. 4

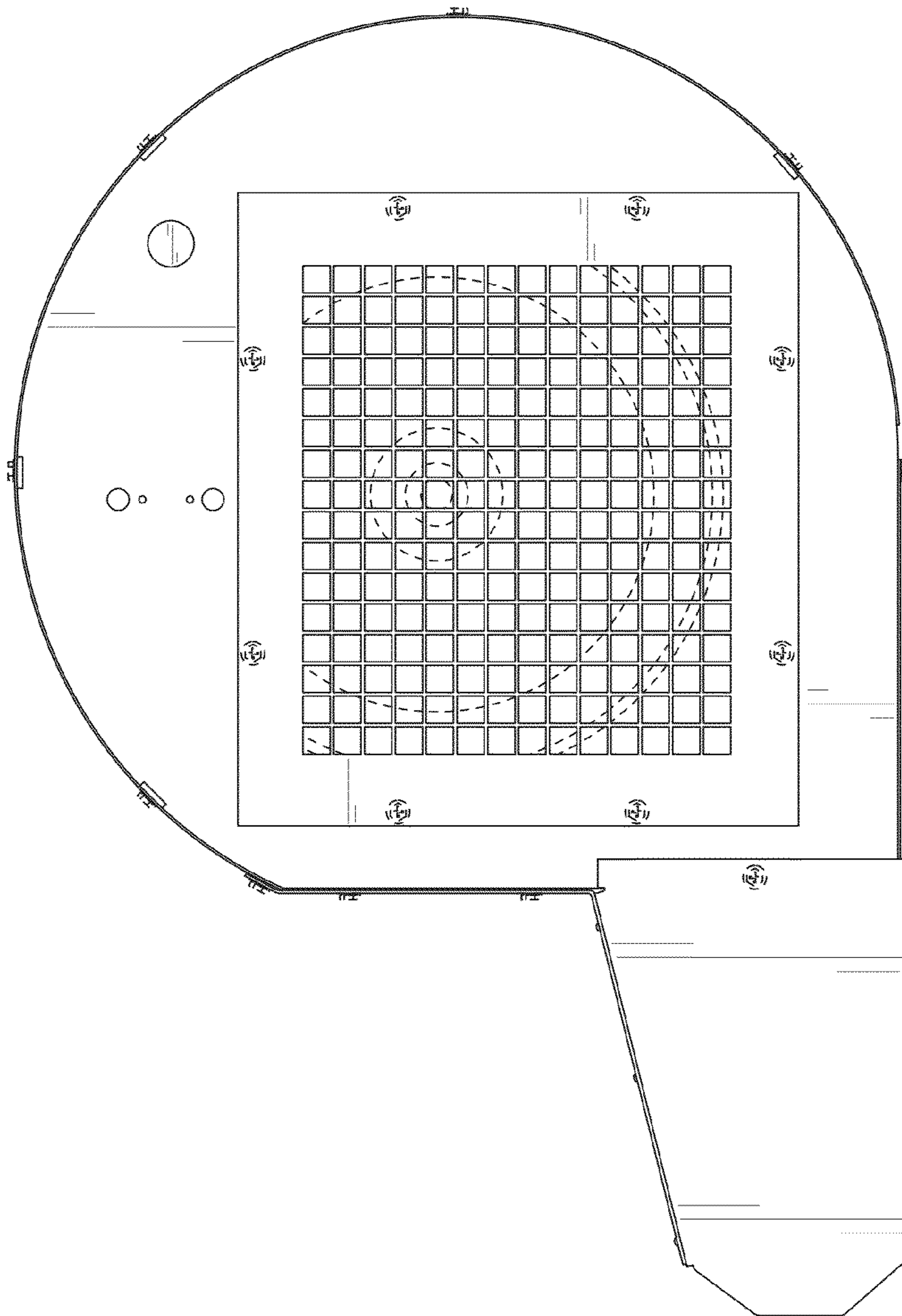

FIG. 5

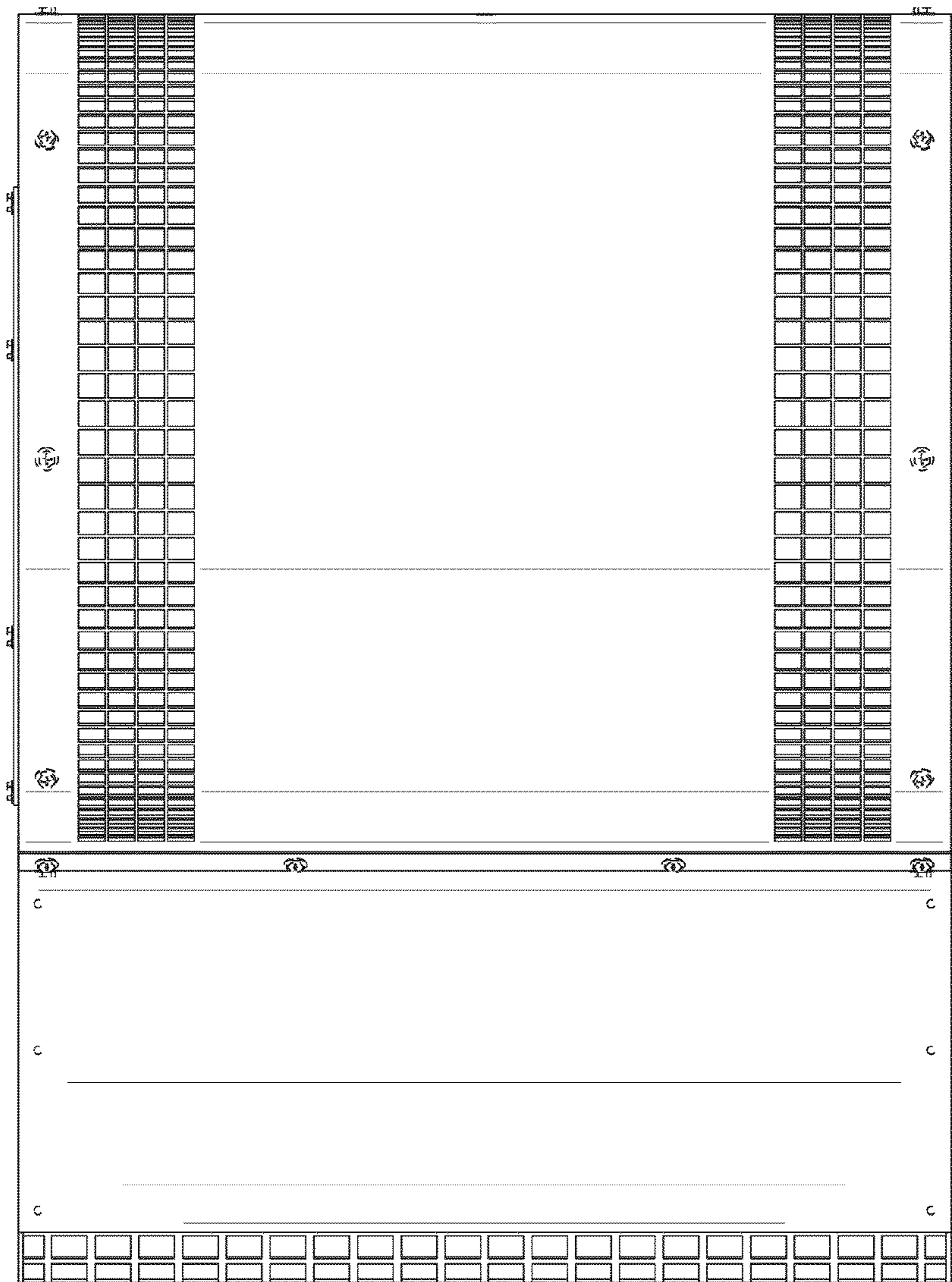

FIG. 6

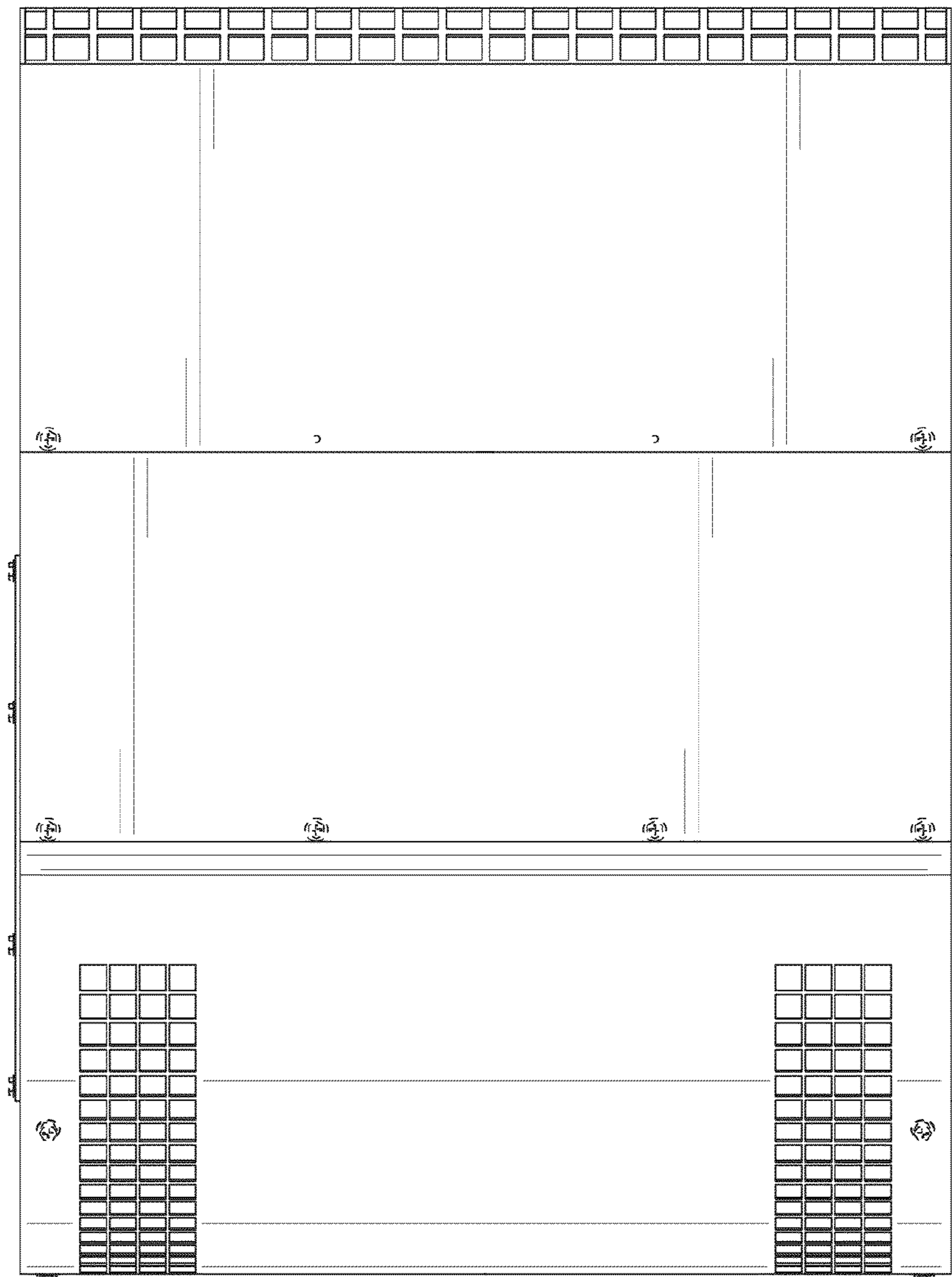

FIG. 7