



US00D705364S

(12) **United States Design Patent**
Miller et al.

(10) **Patent No.:** **US D705,364 S**

(45) **Date of Patent:** **** *May 20, 2014**

(54) **OVAL HOLE CARD READER**

FOREIGN PATENT DOCUMENTS

(75) Inventors: **Arthur C. Miller**, Las Vegas, NV (US);
Dean A. Isaacs, Las Vegas, NV (US)

DE 1039429 9/1958
DE 3807127 A1 9/1989

(Continued)

(73) Assignee: **Tech Art, Inc.**, Las Vegas, NV (US)

Primary Examiner — George D Kirschbaum

(*) Notice: This patent is subject to a terminal disclaimer.

(74) *Attorney, Agent, or Firm* — Kevin P. Crosby; GrayRobinson, P.A.

(**) Term: **14 Years**

(57) **CLAIM**

The ornamental design for oval hole card reader, as shown and described.

(21) Appl. No.: **29/401,723**

DESCRIPTION

(22) Filed: **Sep. 14, 2011**

(51) **LOC (10) Cl.** **21-01**

(52) **U.S. Cl.**
USPC **D21/396**

(58) **Field of Classification Search**
USPC D21/307–208, 334–368, 376–397;
273/236–287, 288–291; D14/385
See application file for complete search history.

FIG. 1 is a left front perspective view of my new design, FIG. 2. is a top plan view thereof, FIG. 3. is a right side elevational view thereof. FIG. 4. is a front elevational view thereof. FIG. 5 is a bottom plan view thereof. FIG. 6 is a rear elevational view thereof, FIG. 7 is a right side elevational view thereof. FIG. 8 is a right front perspective View thereof, FIG. 9 is a left rear perspective view thereof, FIG. 10 is a right rear perspective view thereof. FIG. 11 is a left front perspective view of a third embodiment of the invention. FIG. 12. is a top plan view thereof. FIG. 13, is a right side elevational view thereof. FIG. 14, is a front elevational view thereof, FIG. 15 is a bottom plan view thereof, FIG. 16 is a rear elevational view thereof, FIG. 17 is a right side elevational view thereof, FIG. 18 is a right front perspective view thereof, FIG. 19 is a left rear perspective view thereof; and, FIG. 20 is a right rear perspective view thereof. The broken line showing of mounting and other elements on the bottom of the design is included for the purpose of illustrating portions of the “article” and forms no part of the claimed design.

(56) **References Cited**

U.S. PATENT DOCUMENTS

233,829	A	11/1880	Adt
1,356,398	A	10/1920	Owens
1,590,463	A	6/1926	Wood
1,919,922	A	7/1933	Baker, Jr. et al.
2,046,595	A	7/1936	Yerkes
3,034,512	A	5/1962	Hunter
3,165,319	A	1/1965	Benima
3,222,071	A	12/1965	Lang
3,312,473	A	4/1967	Friedman et al.
3,489,907	A	1/1970	Kenez
3,529,829	A	9/1970	Seifert
3,658,342	A	4/1972	Borea
3,690,670	A	9/1972	Cassady et al.
3,716,238	A	2/1973	Porter

(Continued)

1 Claim, 20 Drawing Sheets

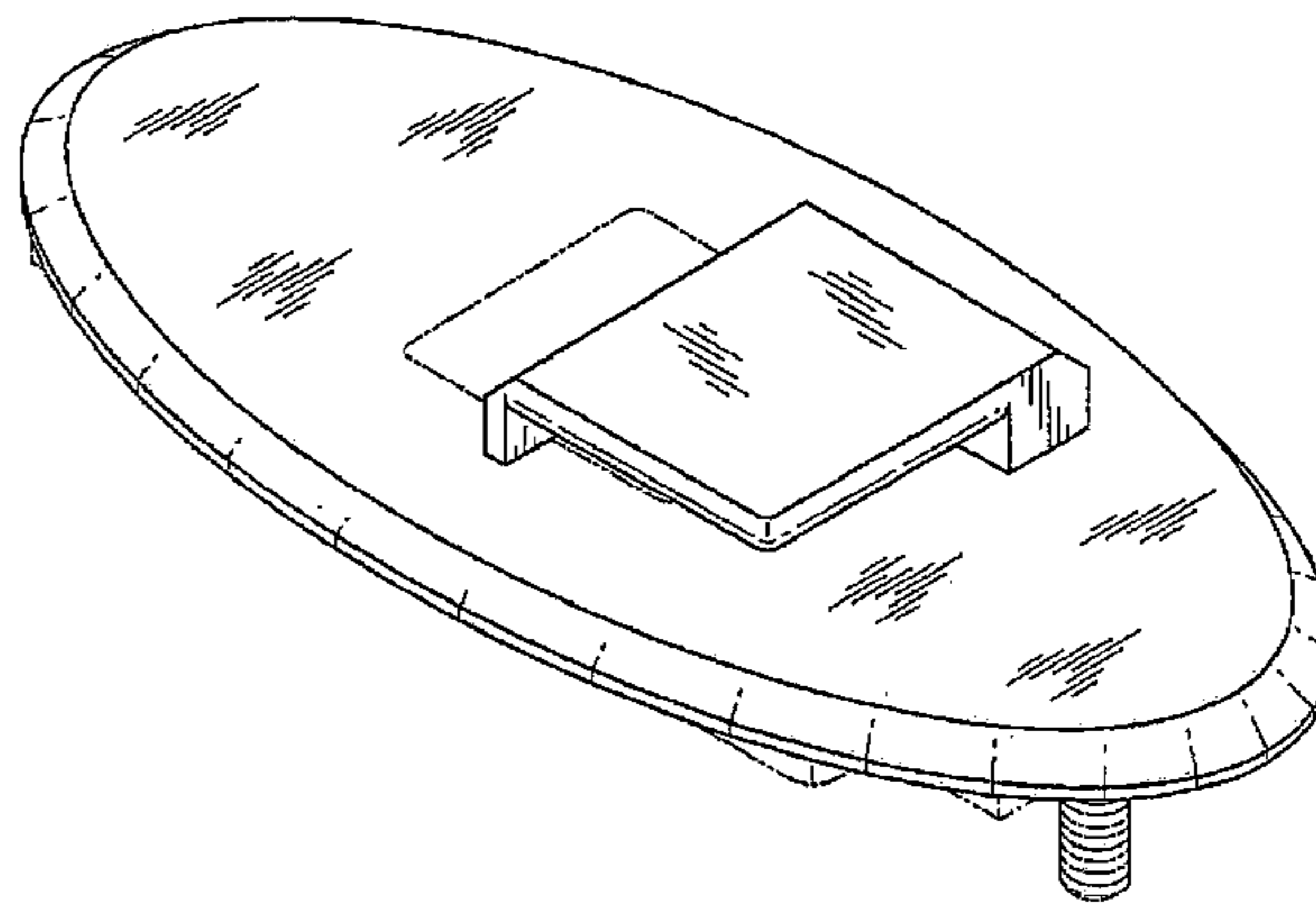
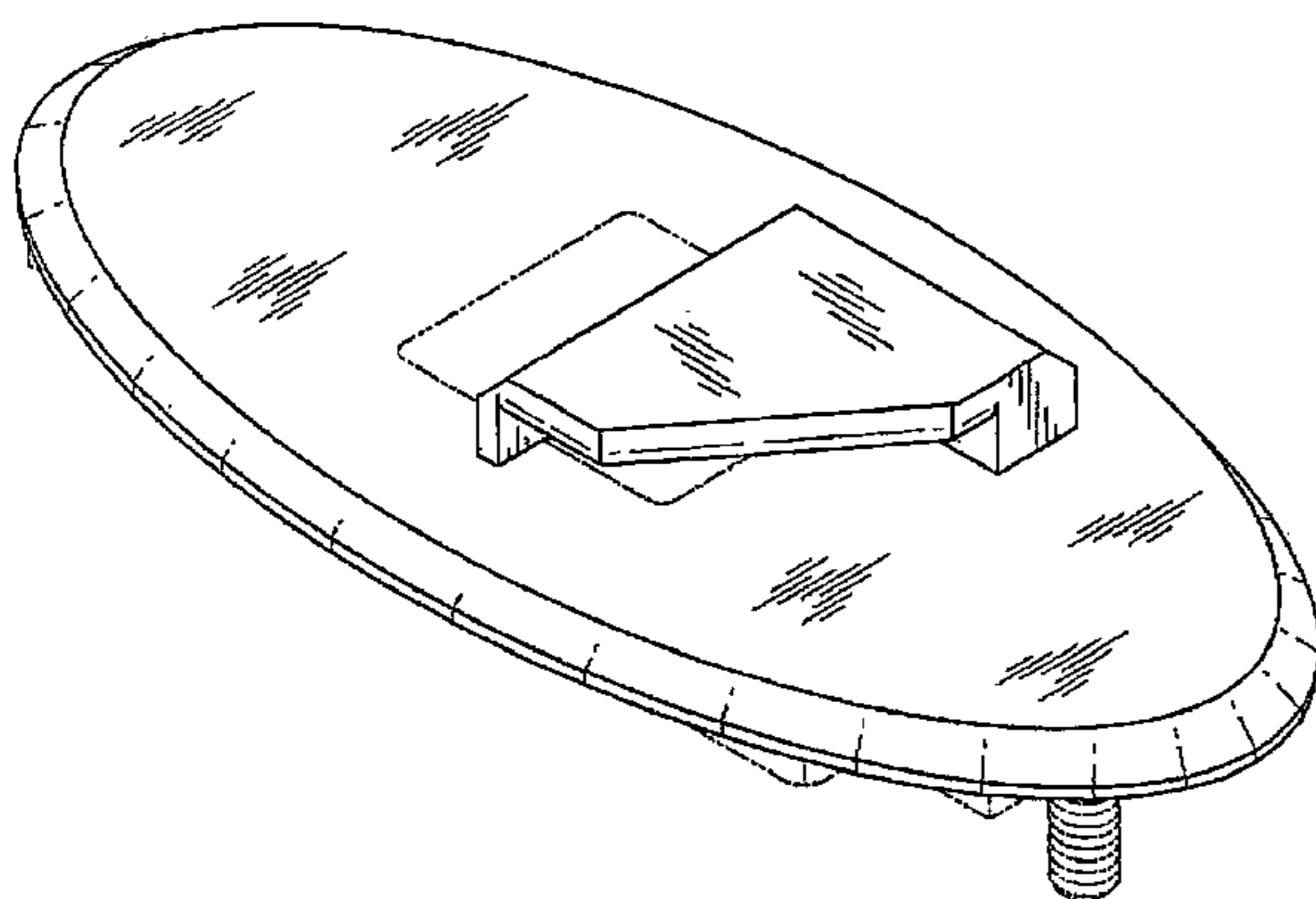

(56)

References Cited

U.S. PATENT DOCUMENTS

3,731,936 A 5/1973 Copeland
 3,742,616 A 7/1973 Heller
 3,743,294 A 7/1973 Forster
 3,751,041 A 8/1973 Seifert
 3,779,554 A 12/1973 Brix
 3,814,436 A 6/1974 Boren
 3,858,797 A 1/1975 Takeuchi
 3,929,339 A 12/1975 Mattioli
 4,026,309 A 5/1977 Howard
 4,146,229 A 3/1979 Morse
 4,314,700 A 2/1982 Dylag
 4,531,187 A 7/1985 Uhland
 4,534,562 A 8/1985 Cuff et al.
 4,667,959 A 5/1987 Pfeiffer et al.
 4,814,589 A 3/1989 Storch et al.
 4,822,050 A 4/1989 Normand et al.
 D317,951 S 7/1991 Miller
 5,039,102 A 8/1991 Miller
 5,067,713 A 11/1991 Soules et al.
 5,110,134 A 5/1992 Laughlin et al.
 5,219,172 A 6/1993 Laughlin et al.
 5,224,712 A 7/1993 Laughlin et al.
 5,283,422 A 2/1994 Storch et al.
 5,312,104 A 5/1994 Miller
 5,362,053 A 11/1994 Miller
 5,364,106 A 11/1994 Laughlin et al.
 5,374,061 A 12/1994 Albrecht
 5,451,054 A 9/1995 Orenstein
 5,531,331 A 7/1996 Barnett
 5,651,548 A 7/1997 French et al.
 5,669,816 A 9/1997 Garczynski et al.
 5,681,039 A 10/1997 Miller
 5,722,893 A 3/1998 Hill et al.
 5,757,876 A 5/1998 Dam et al.
 5,779,546 A 7/1998 Meissner et al.
 5,781,647 A 7/1998 Fishbine et al.
 5,809,482 A 9/1998 Strisower
 5,933,244 A 8/1999 Kiritchenko
 5,941,769 A 8/1999 Order
 5,961,121 A 10/1999 Brown
 6,039,650 A 3/2000 Hill
 6,126,166 A 10/2000 Lorson et al.
 6,254,484 B1 7/2001 McCrea, Jr.
 6,267,671 B1 7/2001 Hogan
 6,299,536 B1 10/2001 Hill
 6,313,871 B1 11/2001 Schubert
 6,346,044 B1 2/2002 McCrea, Jr.
 6,431,984 B2 8/2002 Coyer et al.
 6,460,848 B1 10/2002 Soltys et al.
 D467,921 S * 12/2002 Lin D14/385

6,514,140 B1 2/2003 Storch
 6,517,435 B2 2/2003 Soltys et al.
 6,517,436 B2 2/2003 Soltys et al.
 6,520,857 B2 2/2003 Soltys et al.
 6,527,271 B2 3/2003 Soltys et al.
 6,530,836 B2 3/2003 Soltys et al.
 6,532,297 B1 3/2003 Lindquist
 6,533,276 B2 3/2003 Soltys et al.
 6,567,159 B1 5/2003 Corech
 6,579,180 B2 6/2003 Soltys et al.
 6,595,857 B2 7/2003 Soltys et al.
 6,609,710 B1 8/2003 Order
 6,619,662 B2 9/2003 Miller
 6,626,750 B2 9/2003 Momemy
 6,629,889 B2 10/2003 Mothwurf
 6,638,161 B2 10/2003 Soltys et al.
 6,652,379 B2 11/2003 Soltys et al.
 6,663,490 B2 12/2003 Soltys et al.
 6,685,568 B2 2/2004 Soltys et al.
 6,688,979 B2 2/2004 Soltys et al.
 6,712,696 B2 3/2004 Soltys et al.
 6,758,751 B2 7/2004 Soltys et al.
 6,845,905 B2 1/2005 Blad et al.
 6,848,994 B1 2/2005 Knust et al.
 6,857,961 B2 2/2005 Soltys et al.
 6,964,612 B2 11/2005 Soltys et al.
 7,011,309 B2 3/2006 Soltys et al.
 7,316,615 B2 1/2008 Soltys et al.
 D646,273 S * 10/2011 Daniel D14/385
 D675,618 S * 2/2013 Behar et al. D14/385
 2002/0086727 A1 7/2002 Soltys et al.
 2003/0220136 A1 11/2003 Soltys et al.
 2004/0219975 A1 11/2004 Soltys et al.
 2005/0239542 A1 10/2005 Olsen
 2005/0258597 A1 11/2005 Soltys et al.
 2005/0282623 A1 12/2005 Matsuno et al.
 2006/0019739 A1 1/2006 Soltys et al.
 2006/0063577 A1 3/2006 Downs, III et al.
 2006/0199649 A1 9/2006 Soltys et al.

FOREIGN PATENT DOCUMENTS

EP 0310516 A1 4/1989
 FR 1356398 2/1964
 FR 2109213 5/1972
 FR 2186839 1/1974
 FR 2427107 12/1979
 FR 2576518 8/1986
 GB 2061490 A 5/1981
 WO 9942186 A1 8/1999
 WO 0120489 A1 3/2001

* cited by examiner

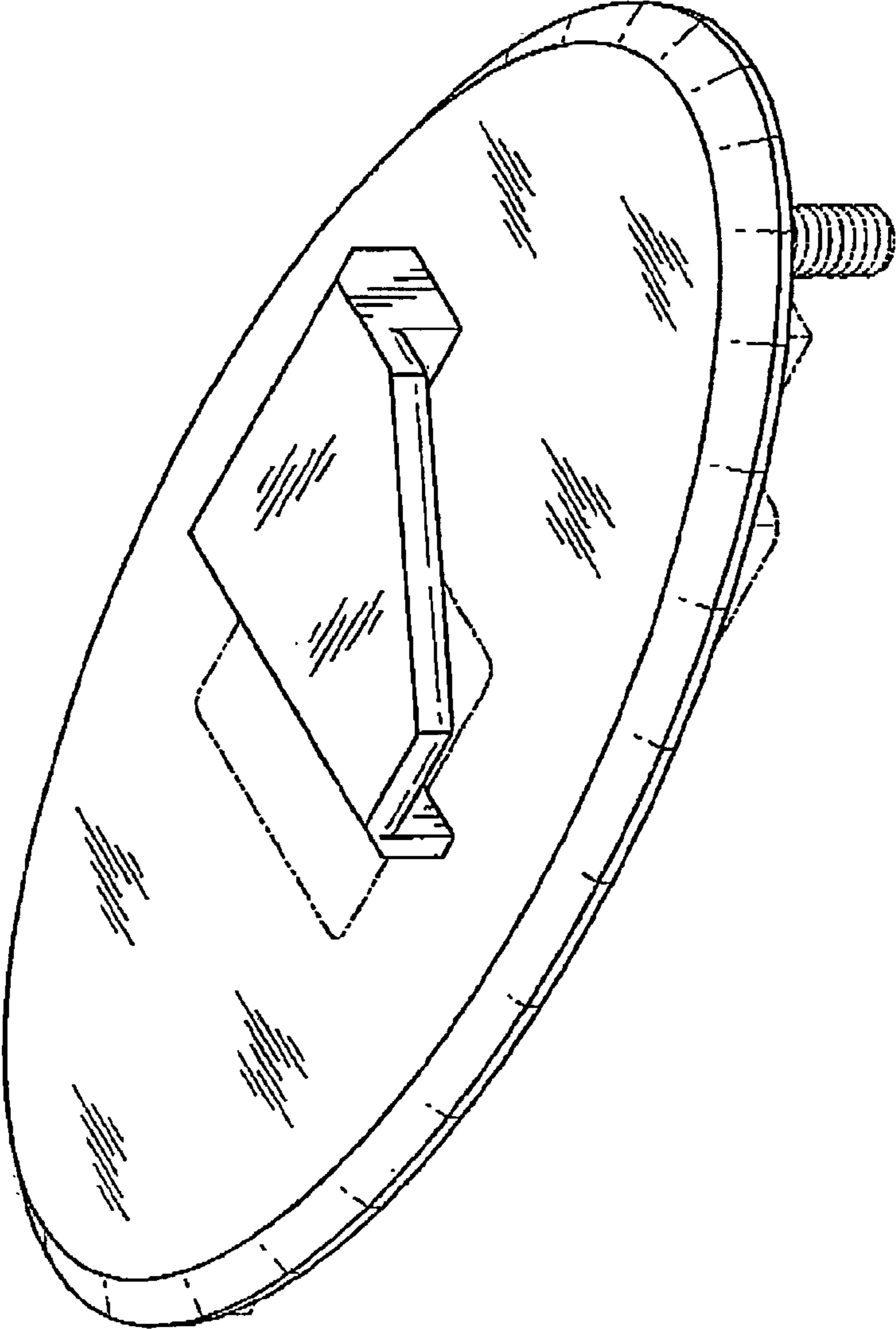

FIG. 1

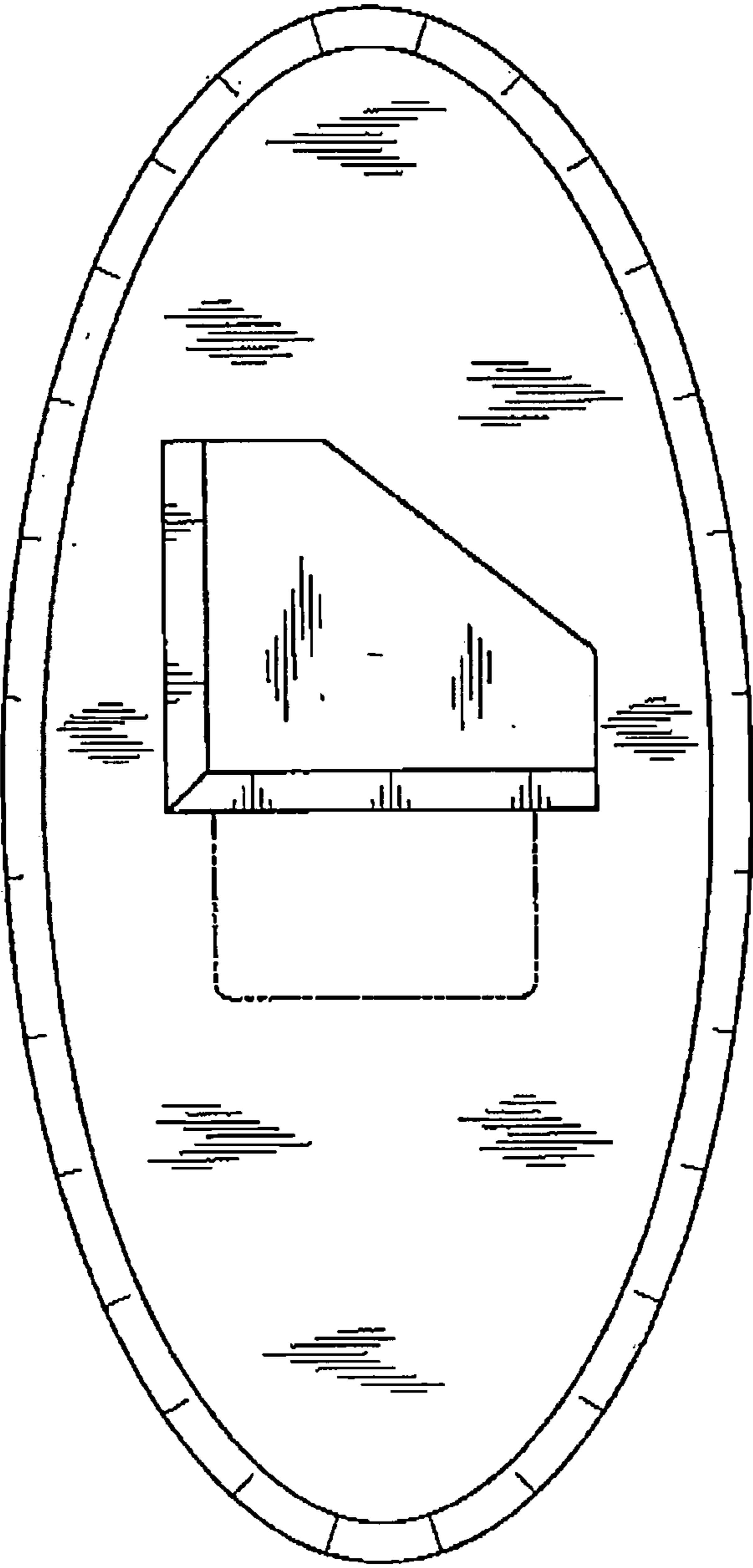

FIG. 2

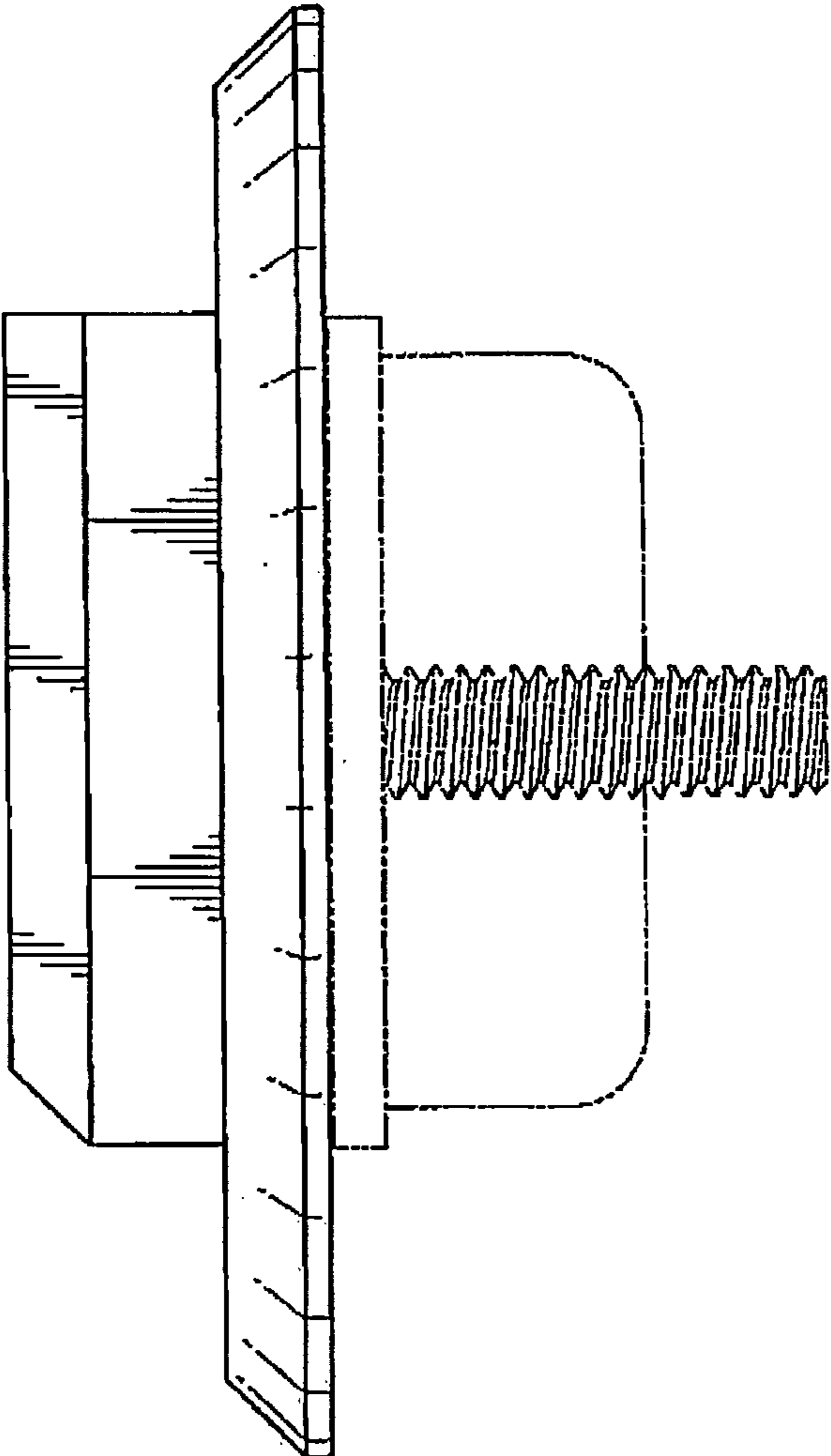

FIG. 3

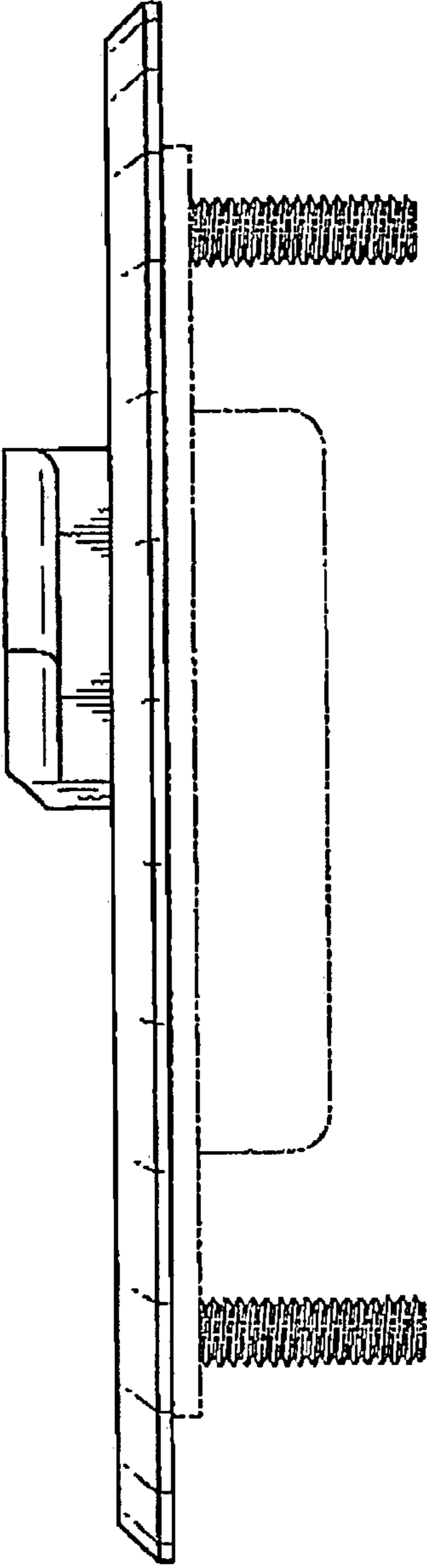

FIG. 4

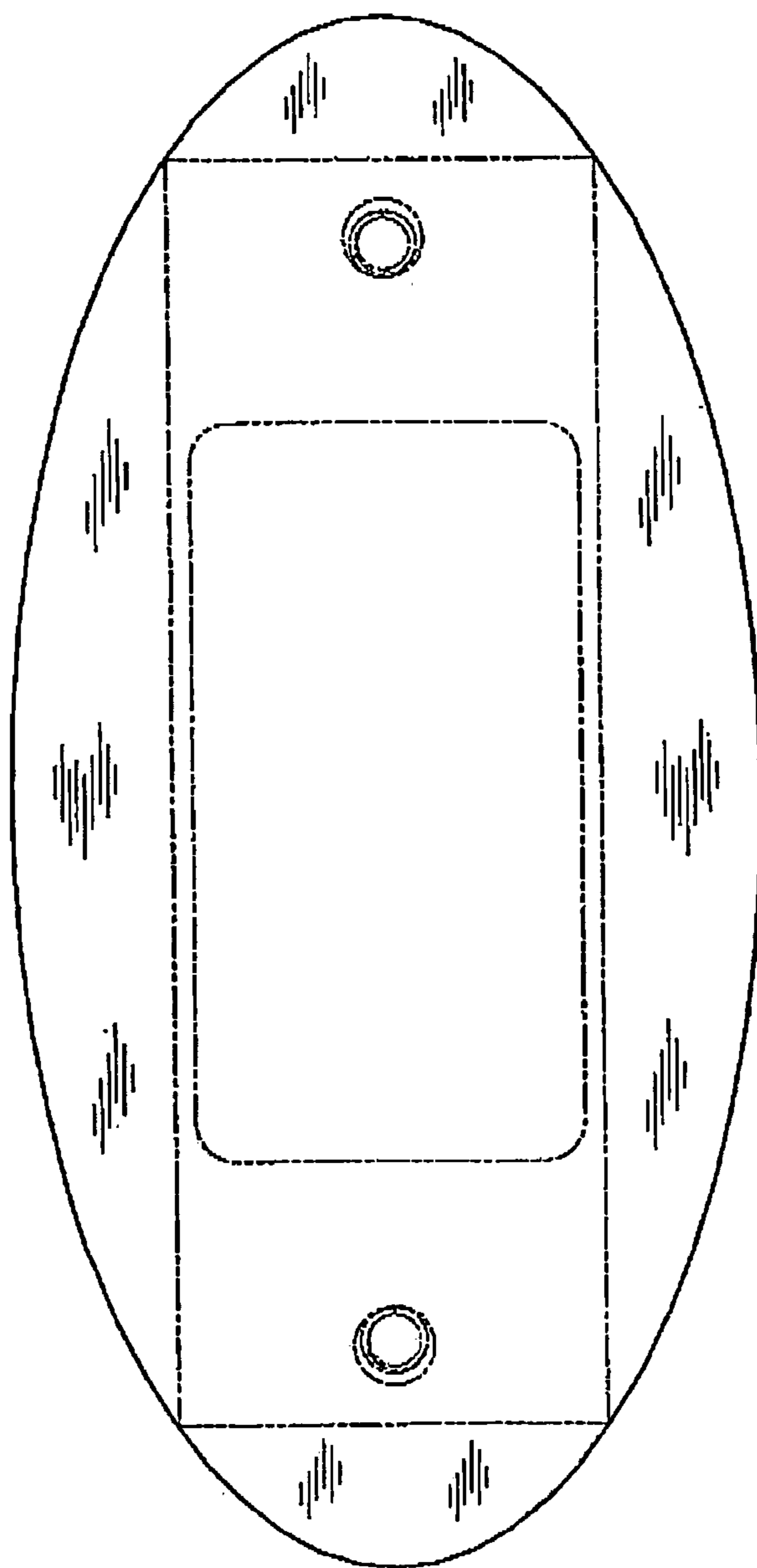

FIG. 5

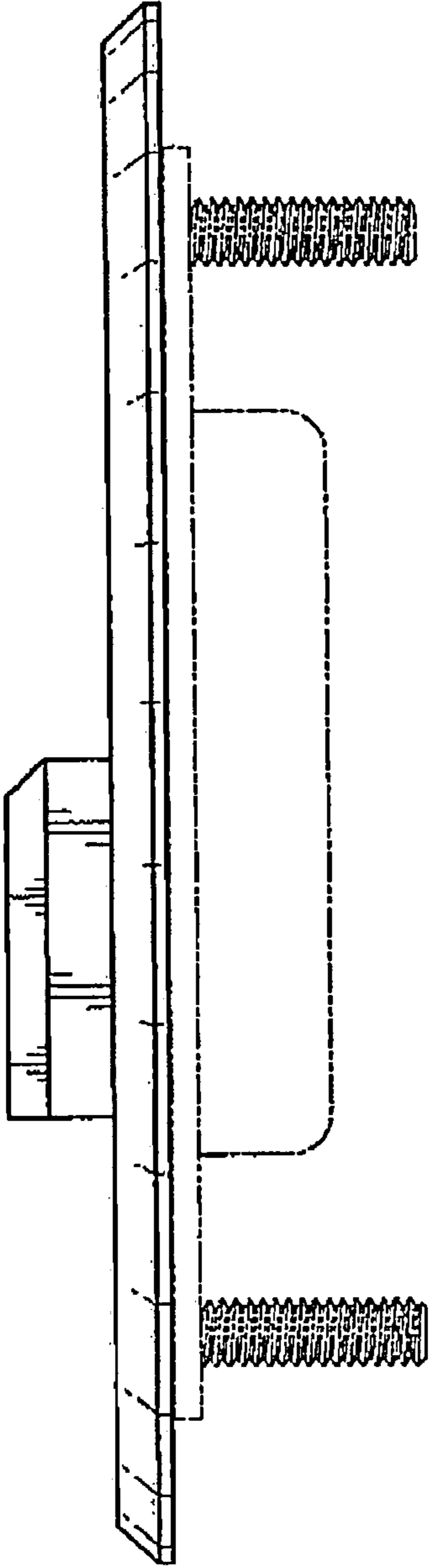

FIG. 6

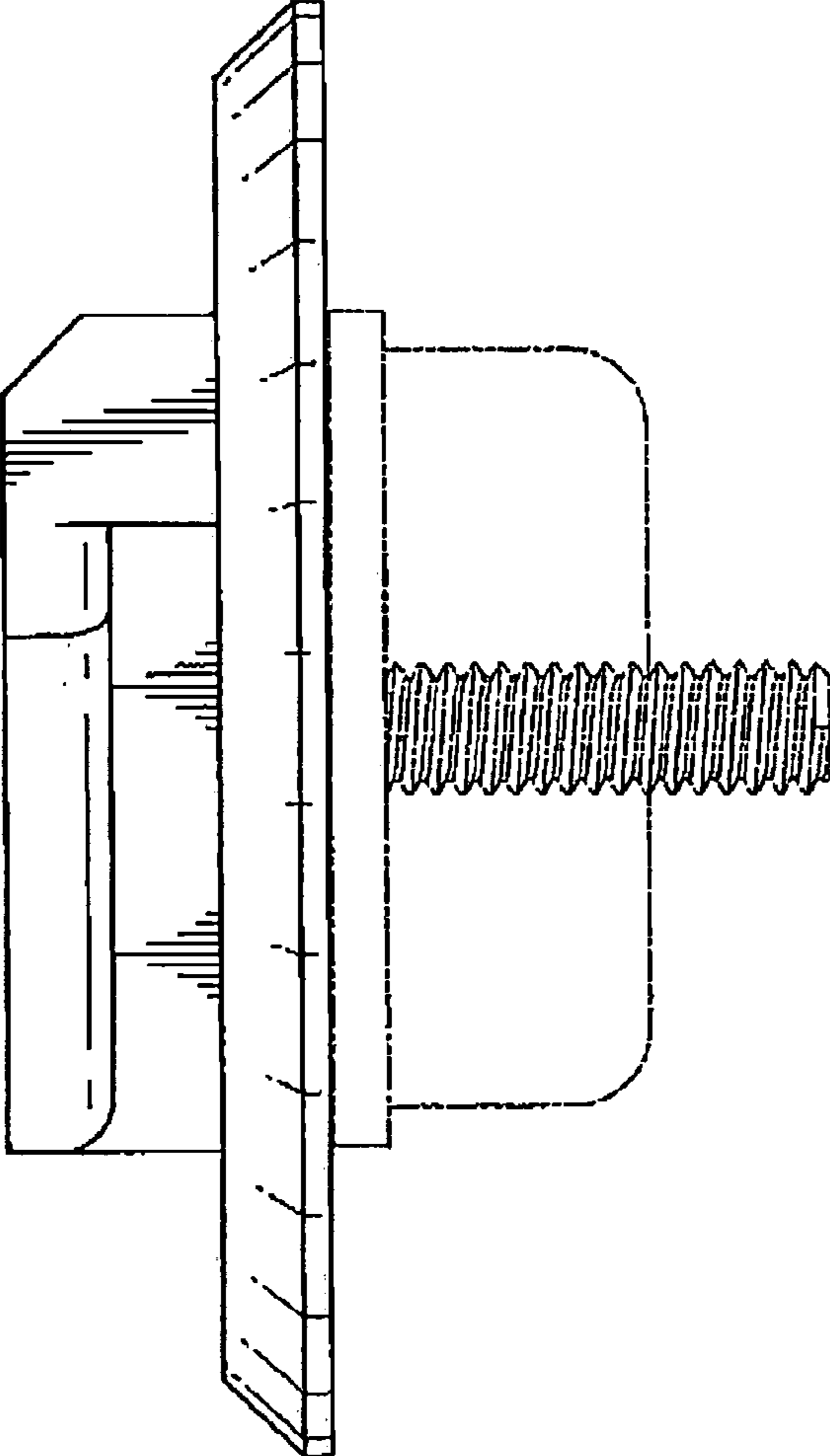

FIG. 7

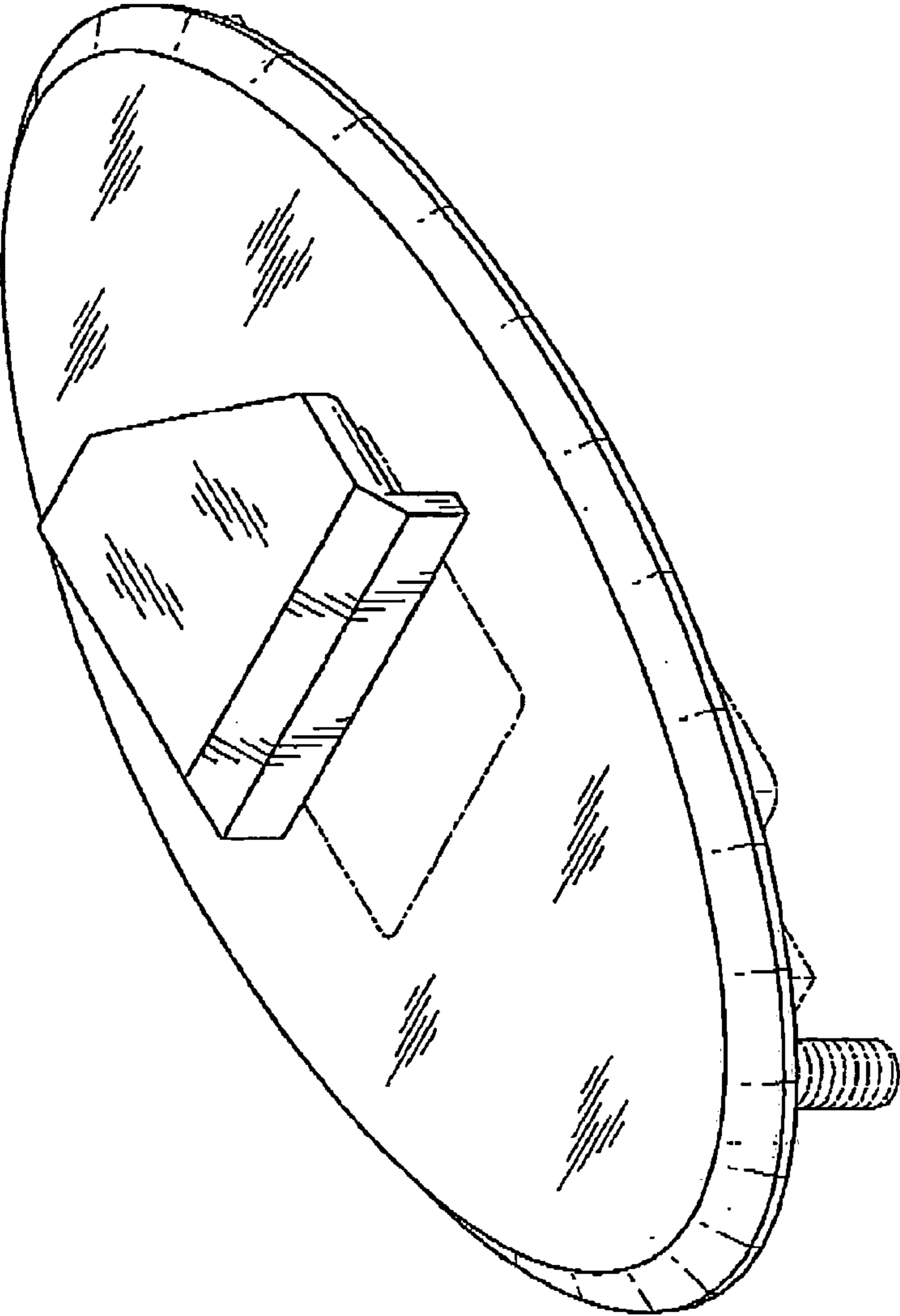

FIG. 8

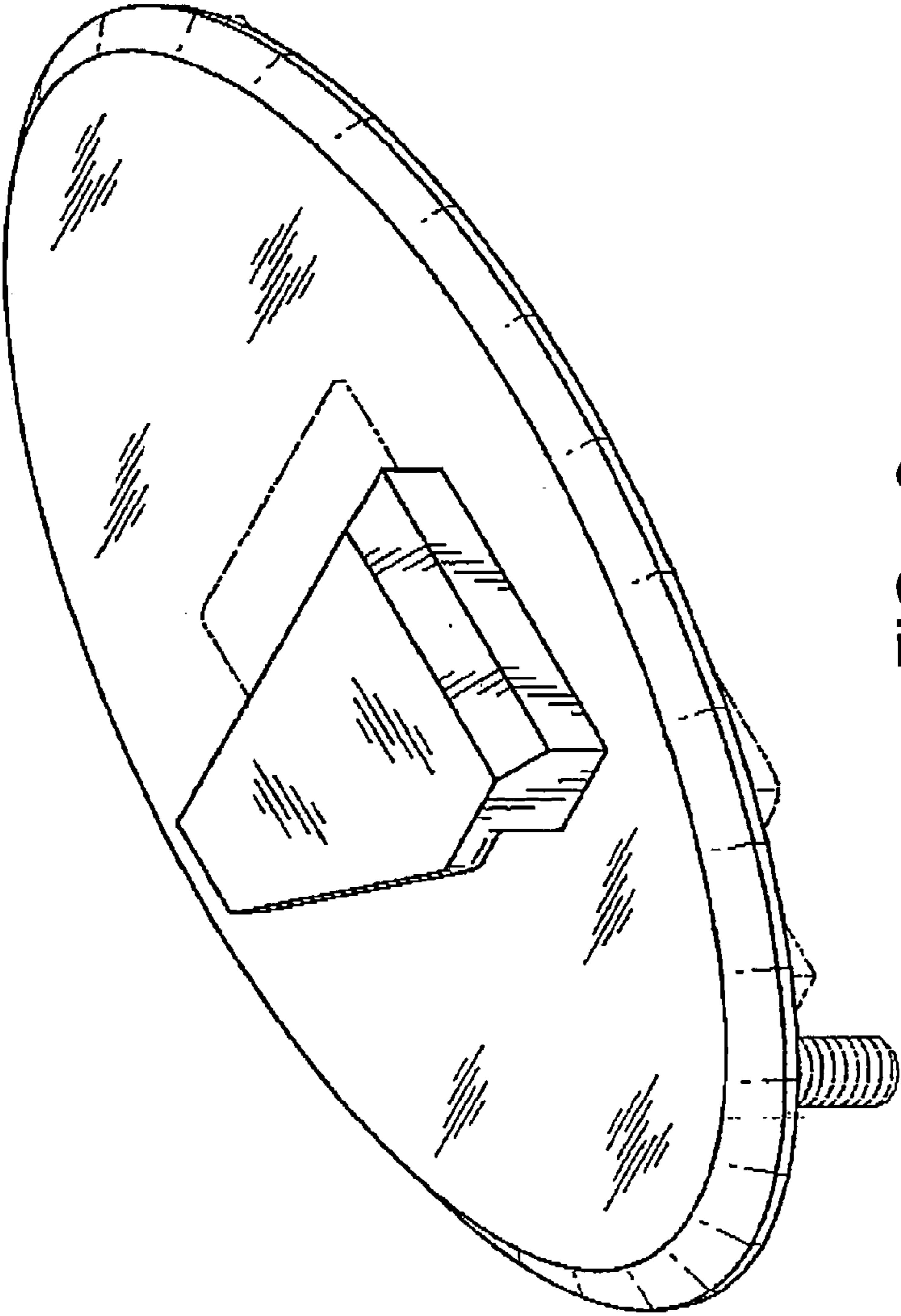

FIG. 9

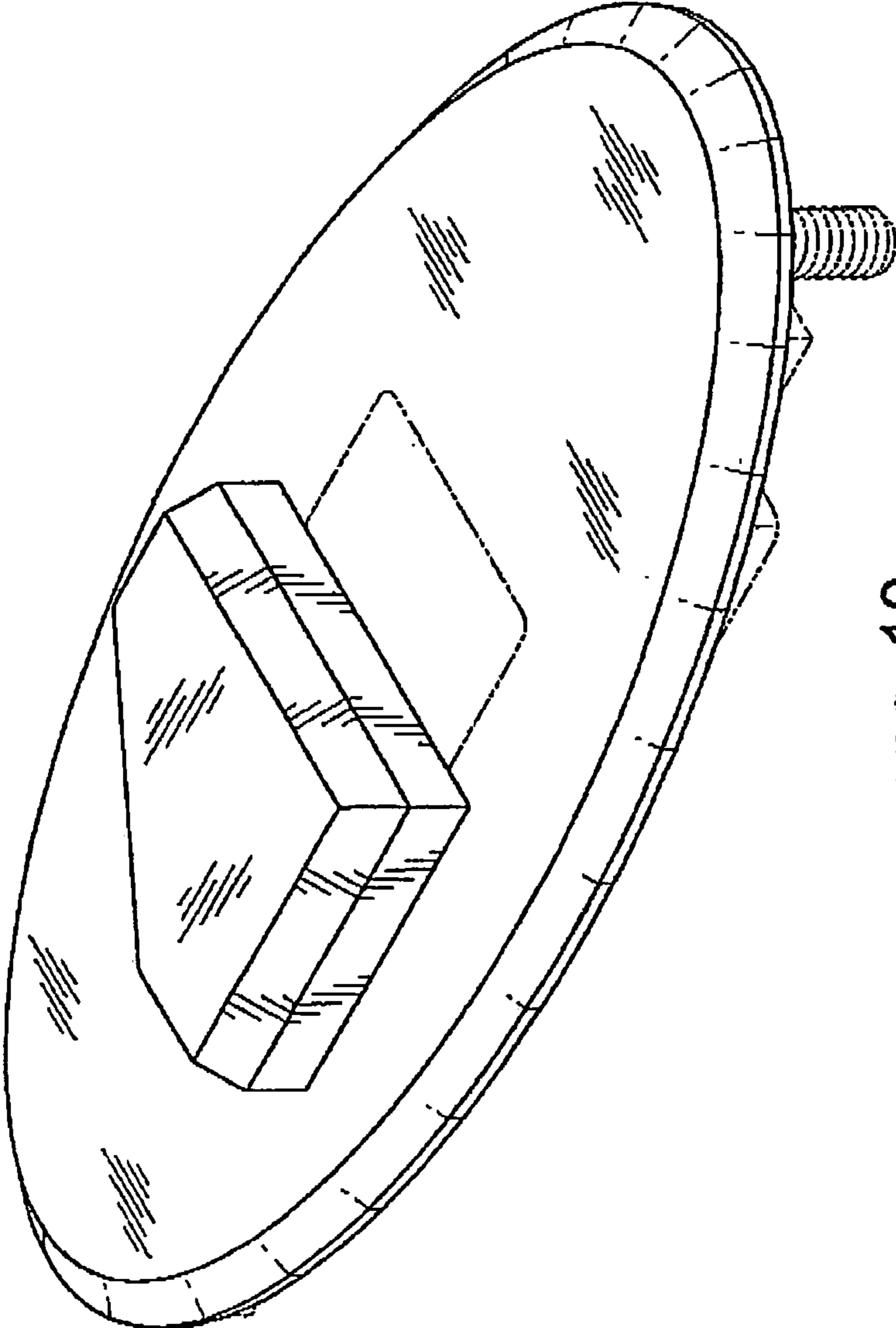

FIG. 10

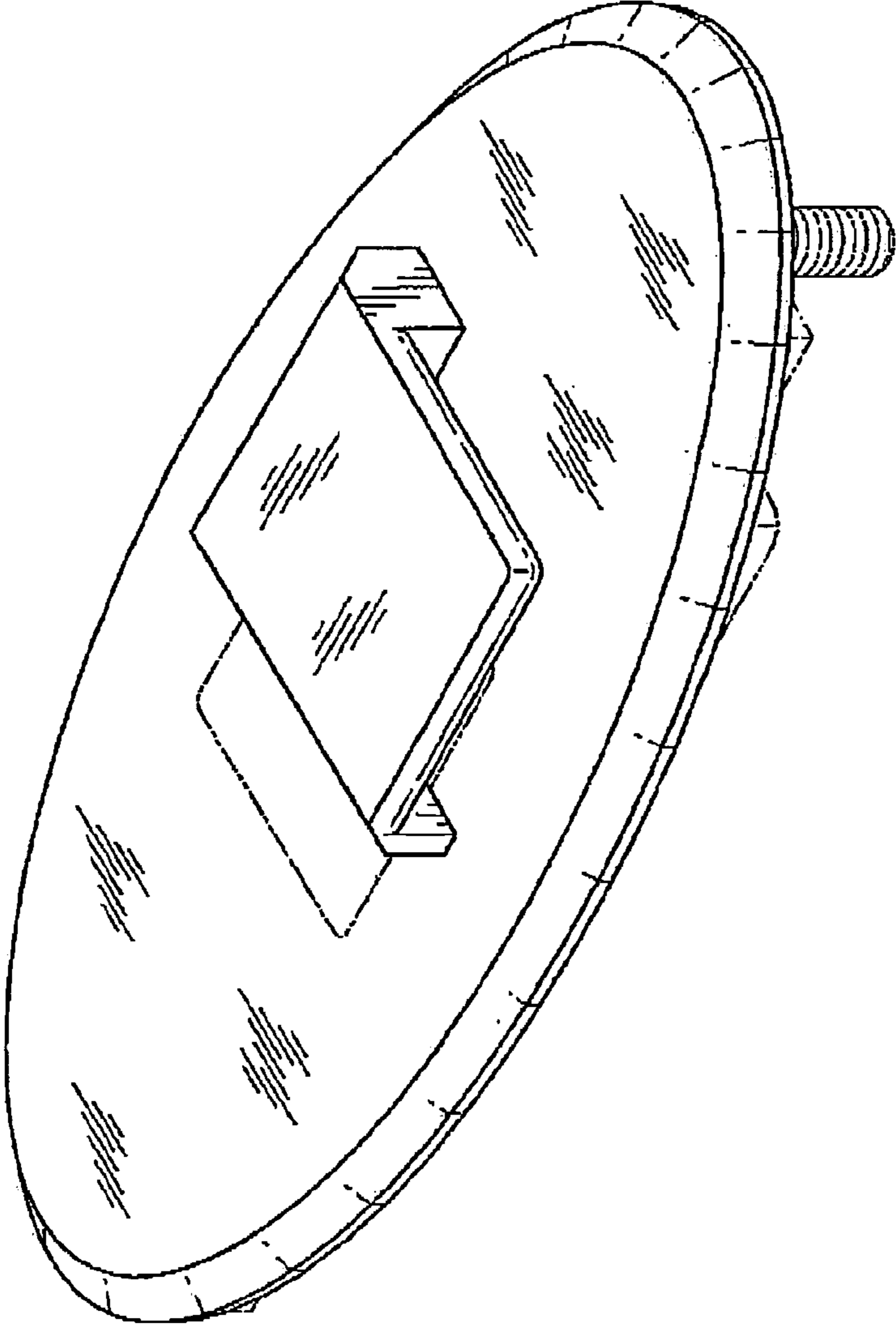

FIG. 11

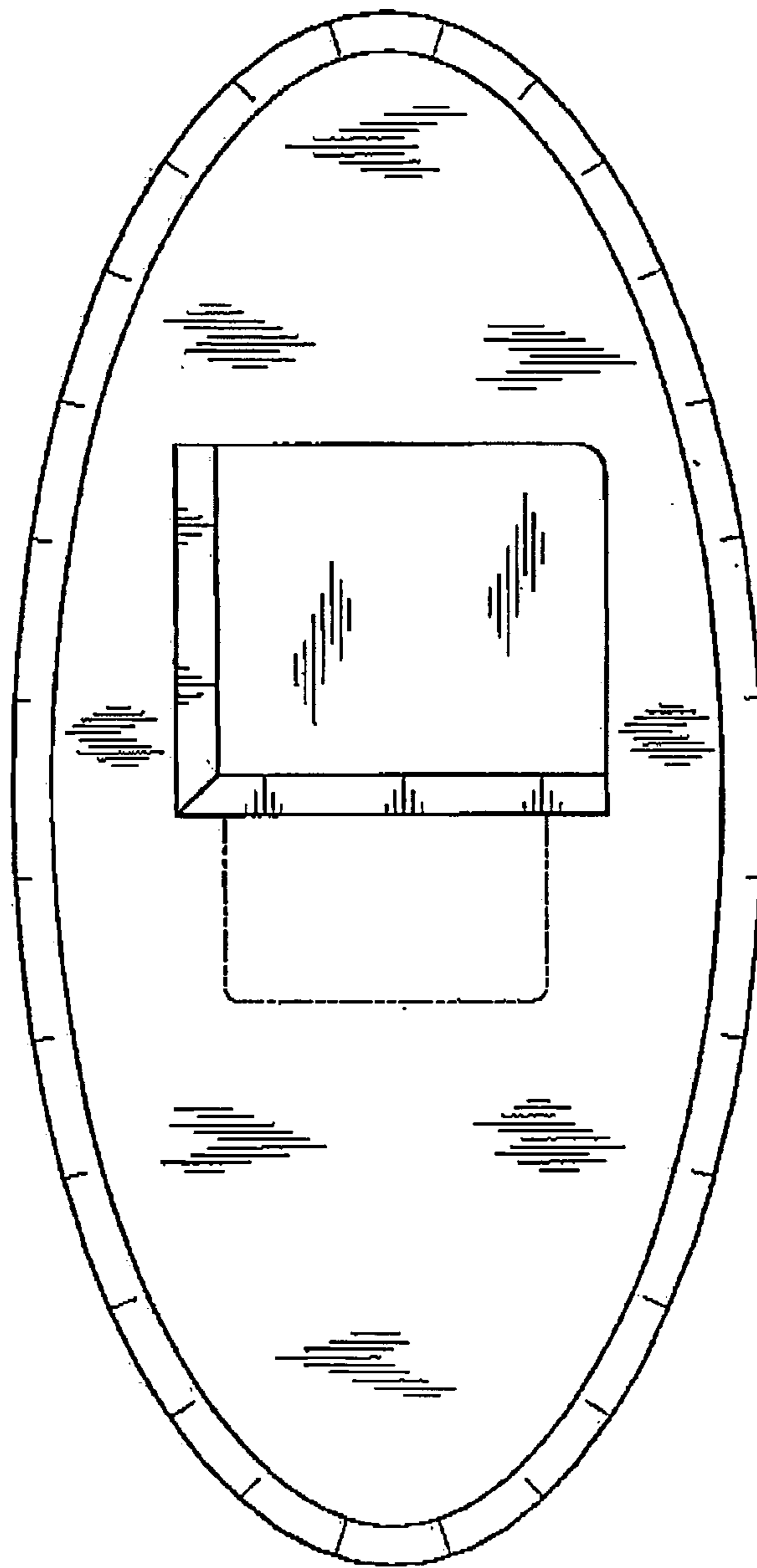

FIG. 12

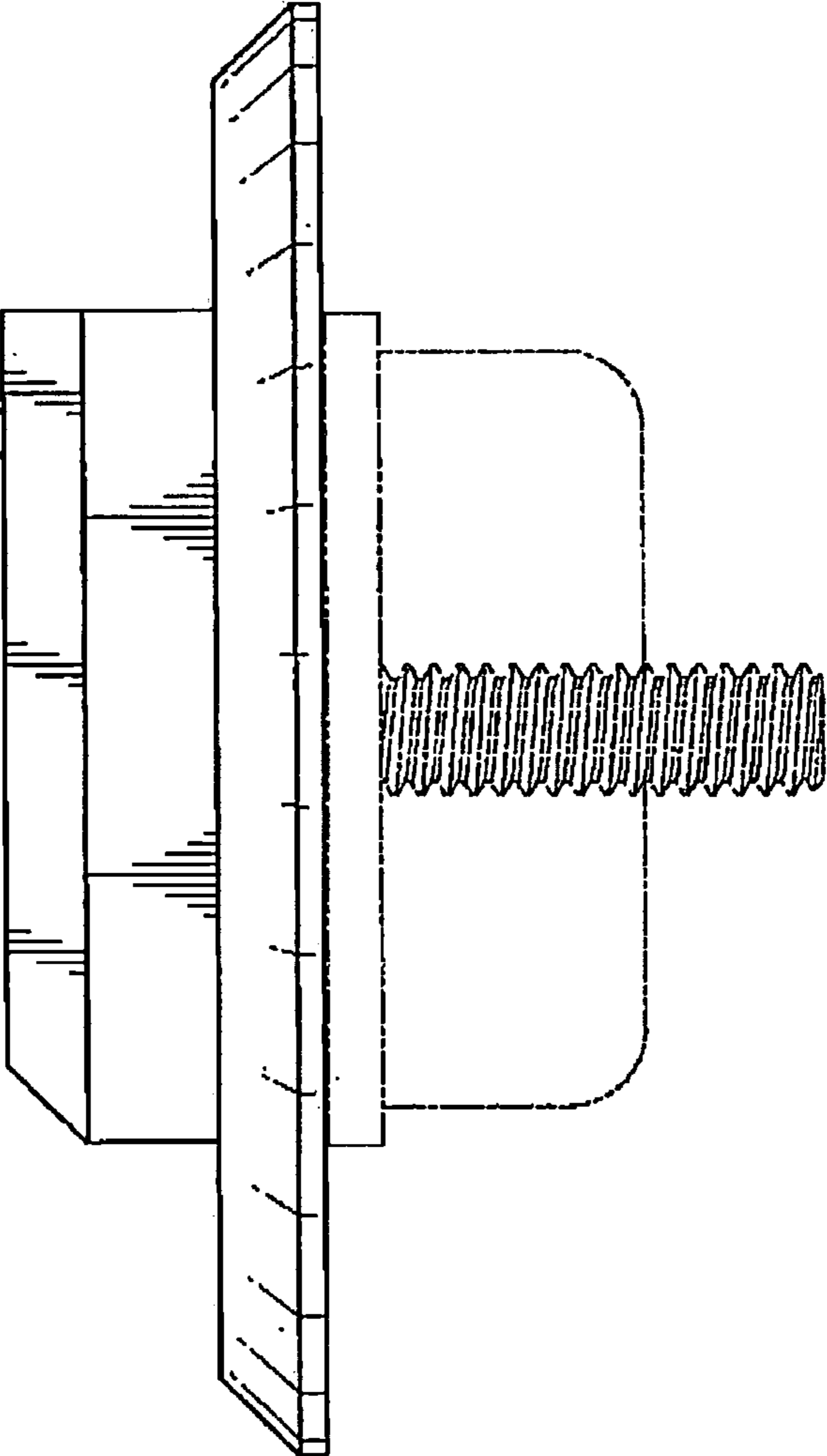

FIG. 13

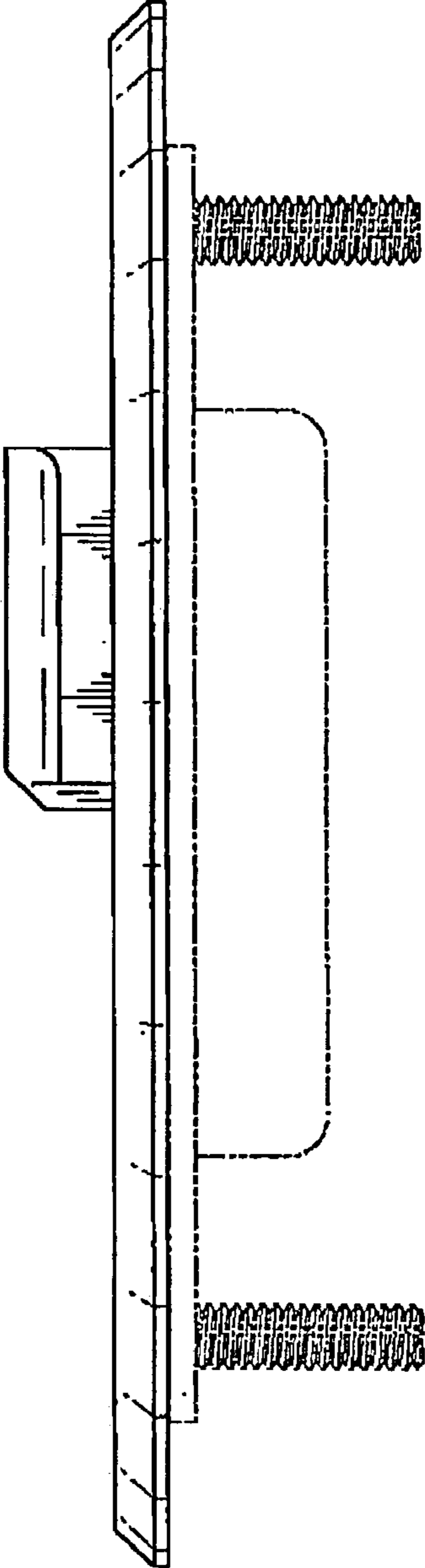

FIG. 14

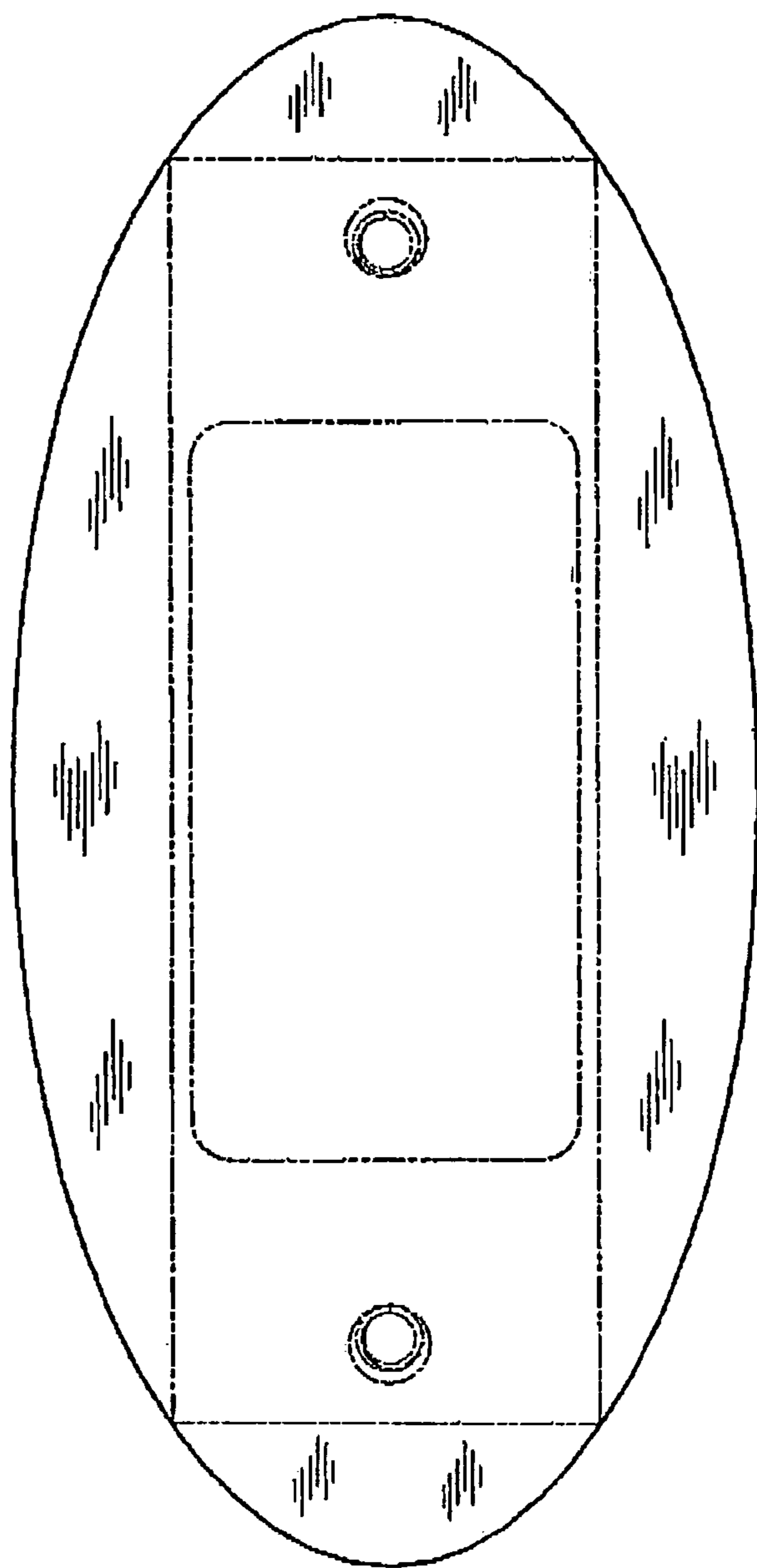

FIG. 15

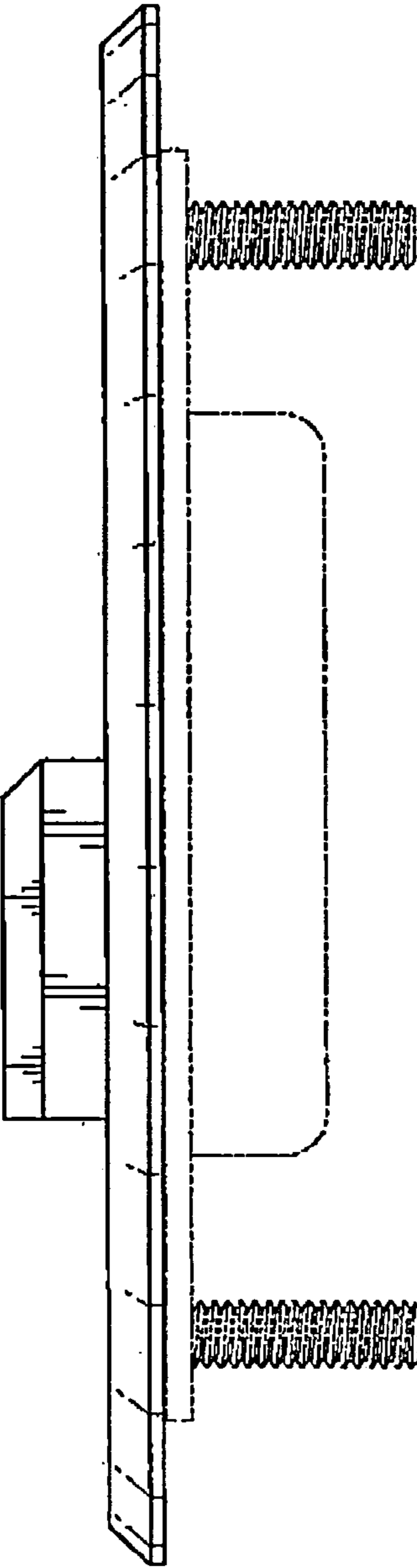

FIG. 16

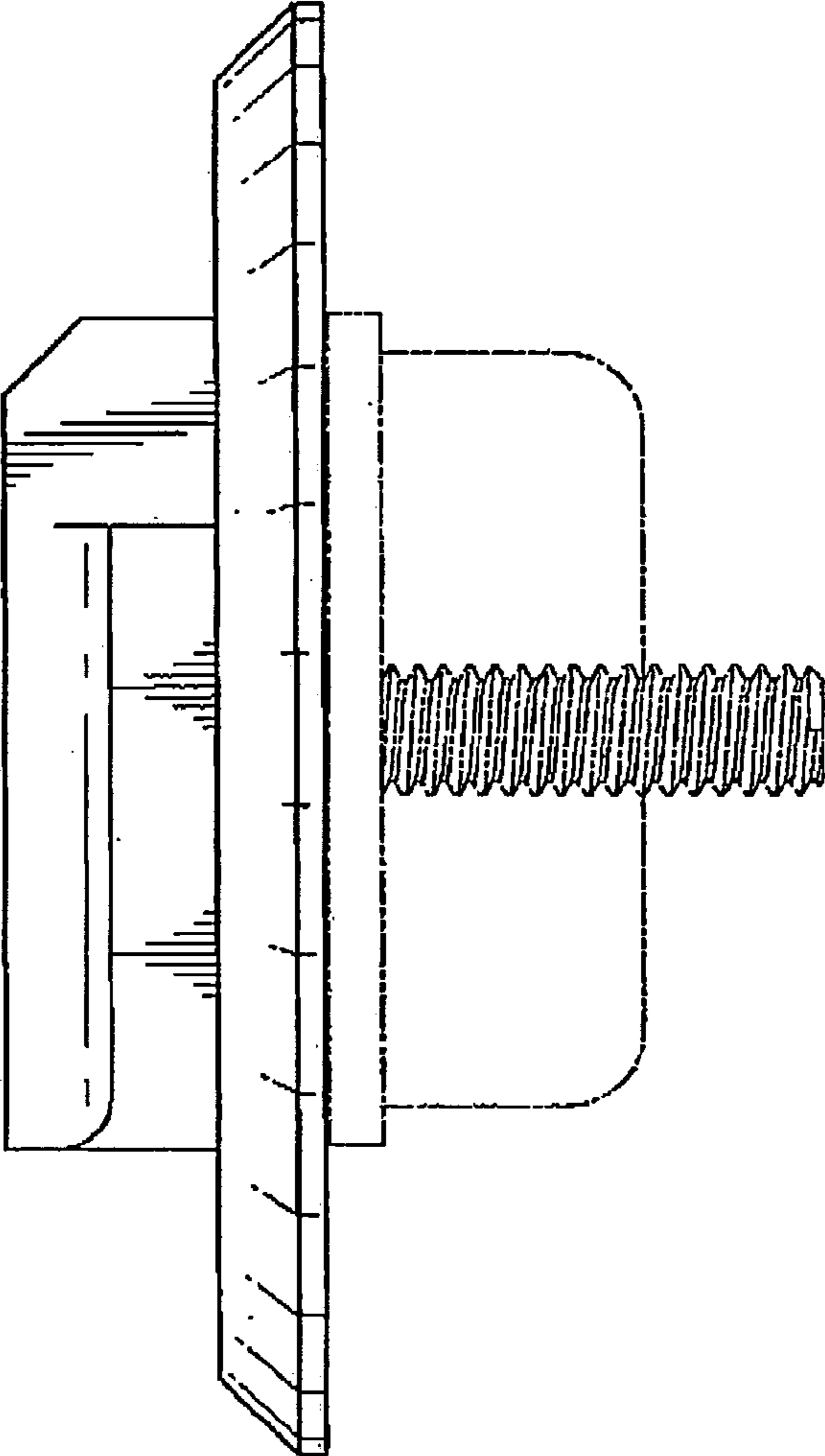

FIG. 17

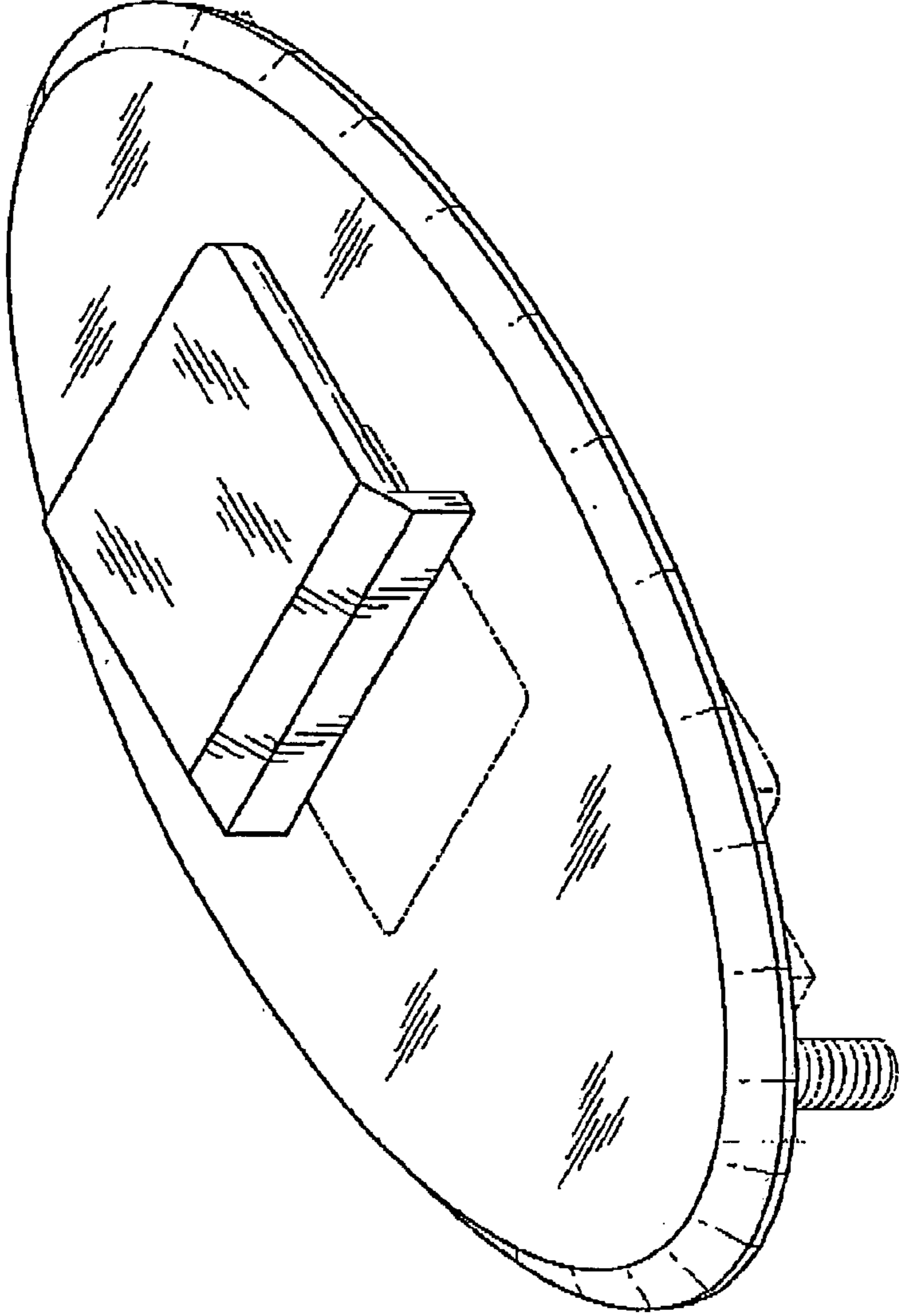

FIG. 18

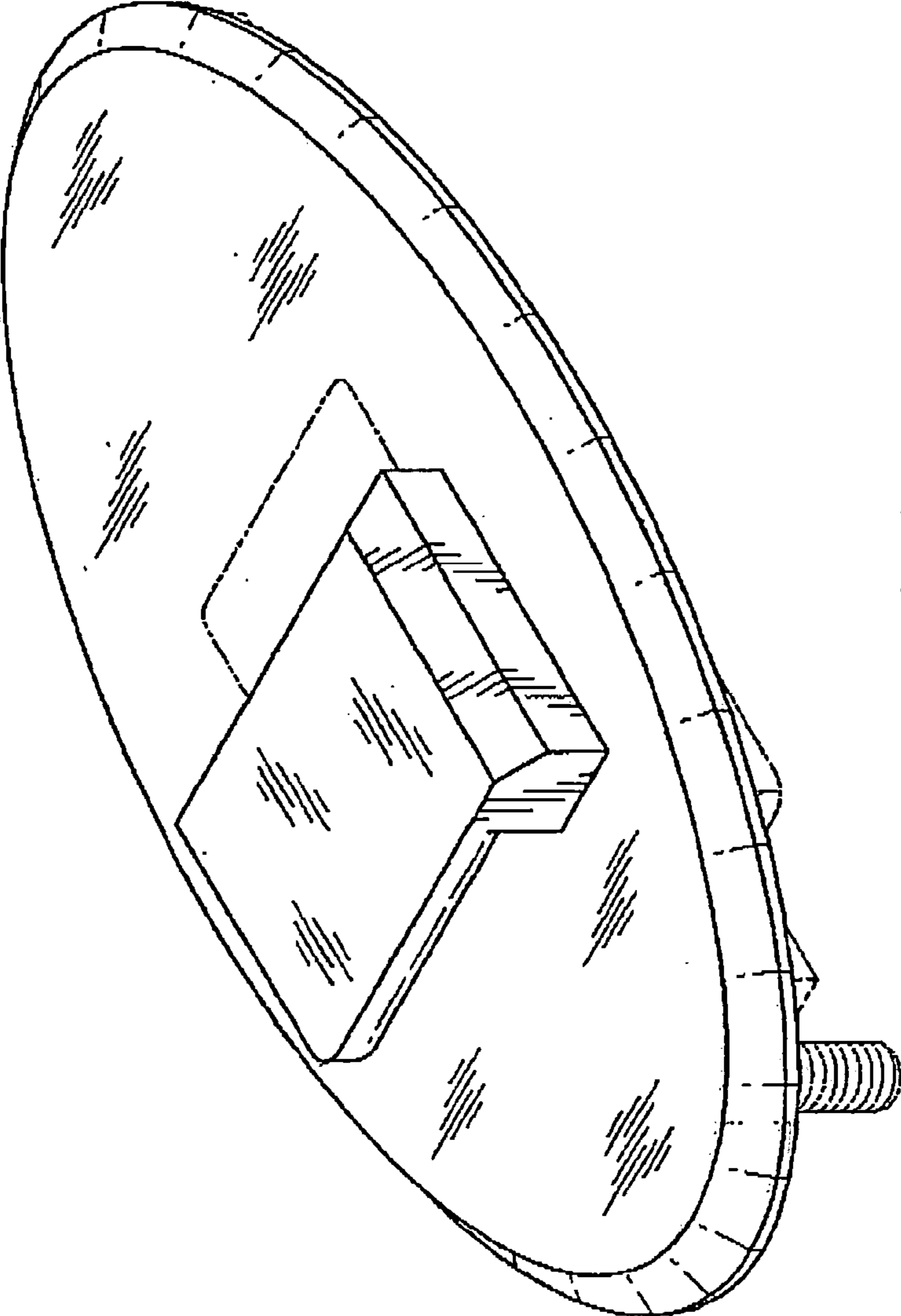

FIG. 19

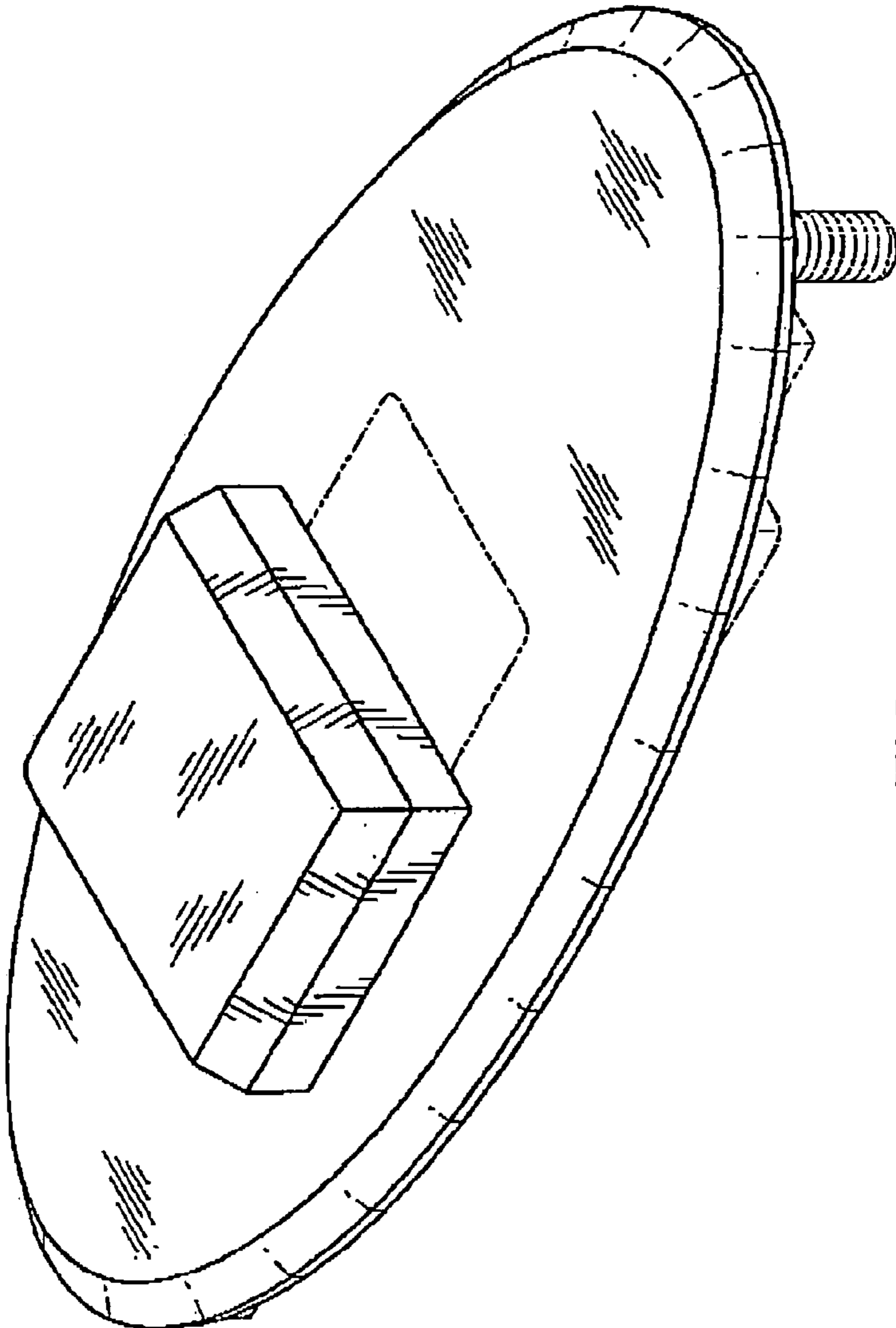

FIG. 20