



US00D705360S

(12) **United States Design Patent**
Mar

(10) **Patent No.:** **US D705,360 S**

(45) **Date of Patent:** **** May 20, 2014**

(54) **VIDEO GAME CONSOLE**

(71) Applicant: **Steven Mar**, South El Monte, CA (US)

(72) Inventor: **Steven Mar**, South El Monte, CA (US)

(**) Term: **14 Years**

(21) Appl. No.: **29/442,403**

(22) Filed: **Feb. 25, 2013**

(51) **LOC (10) Cl.** **21-01**

(52) **U.S. Cl.**
USPC **D21/332**

(58) **Field of Classification Search**
USPC D21/324, 332, 333, 328; 273/148 B;
463/1, 29-25, 43-47; 345/156-167,
345/905; D14/496, 483, 475, 477
See application file for complete search history.

(56) **References Cited**

U.S. PATENT DOCUMENTS

D299,726	S *	2/1989	Yukawa	D21/332
D379,832	S *	6/1997	Ashida	D21/332
D402,328	S *	12/1998	Ashida	D21/332
5,888,134	A *	3/1999	McNair, Jr.	454/184
6,022,274	A *	2/2000	Takeda et al.	463/44
6,254,477	B1 *	7/2001	Sasaki et al.	463/1

6,394,905	B1 *	5/2002	Takeda et al.	463/29
6,565,444	B2 *	5/2003	Nagata et al.	463/46
D503,750	S *	4/2005	Kit et al.	D21/324
7,003,588	B1 *	2/2006	Takeda et al.	710/8
D516,634	S *	3/2006	Man-tat	D21/332
D522,068	S *	5/2006	Man-tat	D21/332
D523,859	S *	6/2006	Deckers	D14/435

* cited by examiner

Primary Examiner — Prabhakar Deshmukh

(74) *Attorney, Agent, or Firm* — Raymond Y. Chan; David and Raymond Patent Firm

(57) **CLAIM**

The ornamental design for a video game console, as shown and described.

DESCRIPTION

FIG. 1 is a rear perspective view of video game console showing my new design.
FIG. 2 is a front perspective view thereof.
FIG. 3 is a top view thereof.
FIG. 4 is a bottom view thereof.
FIG. 5 is a rear view thereof.
FIG. 6 is a front view thereof.
FIG. 7 is a left view thereof; and,
FIG. 8 is aright view thereof.

1 Claim, 8 Drawing Sheets

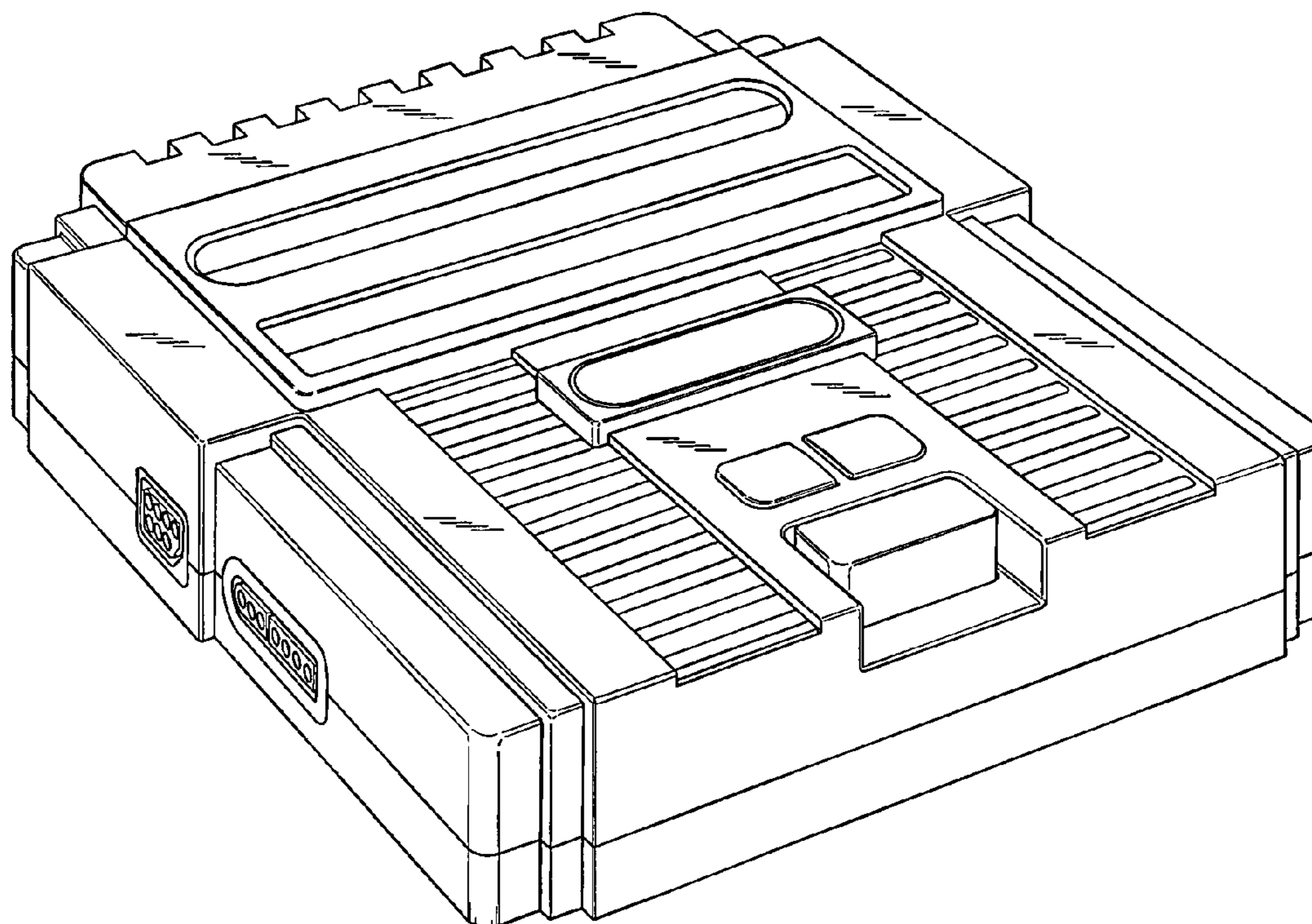

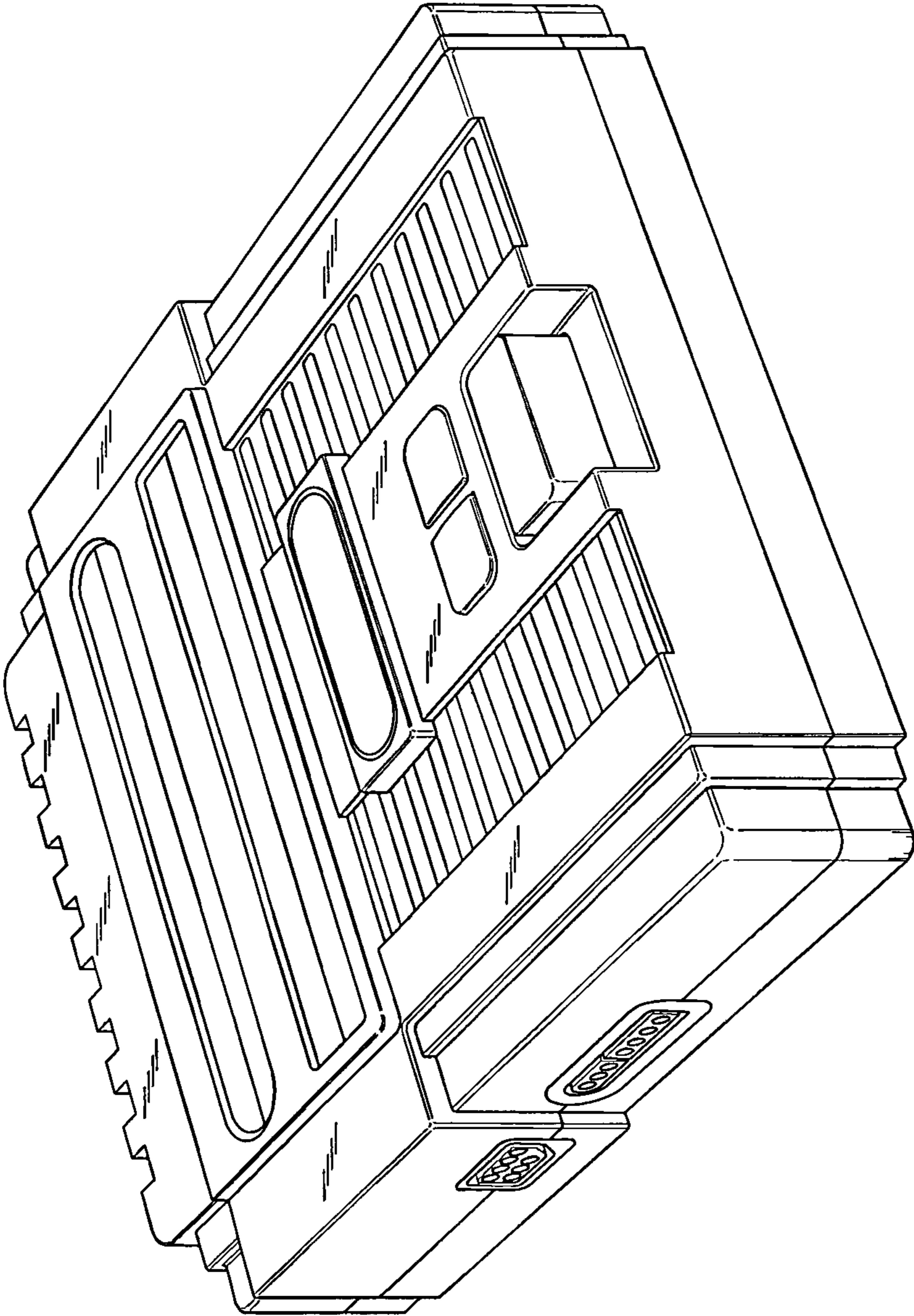

FIG.1

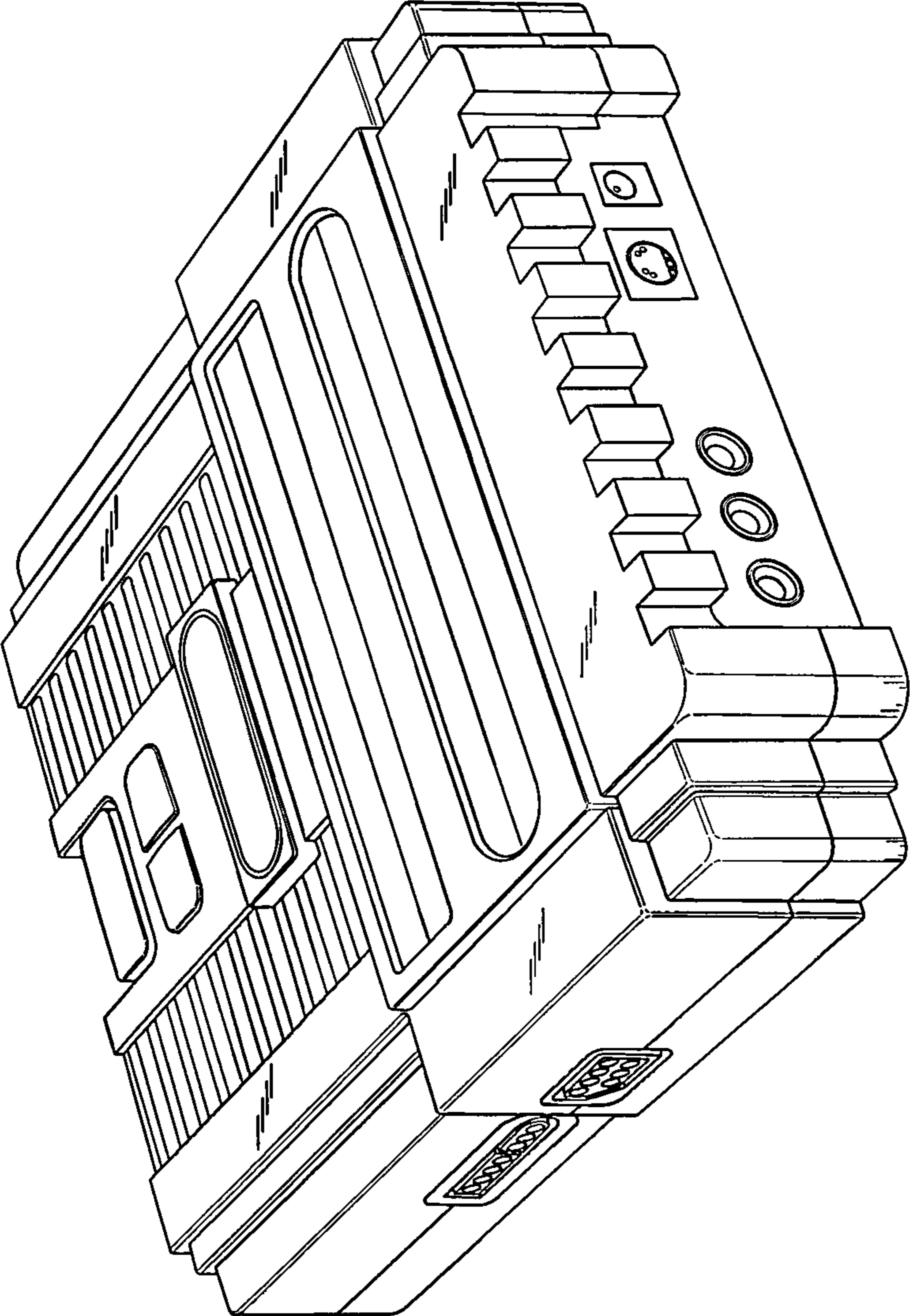

FIG.2

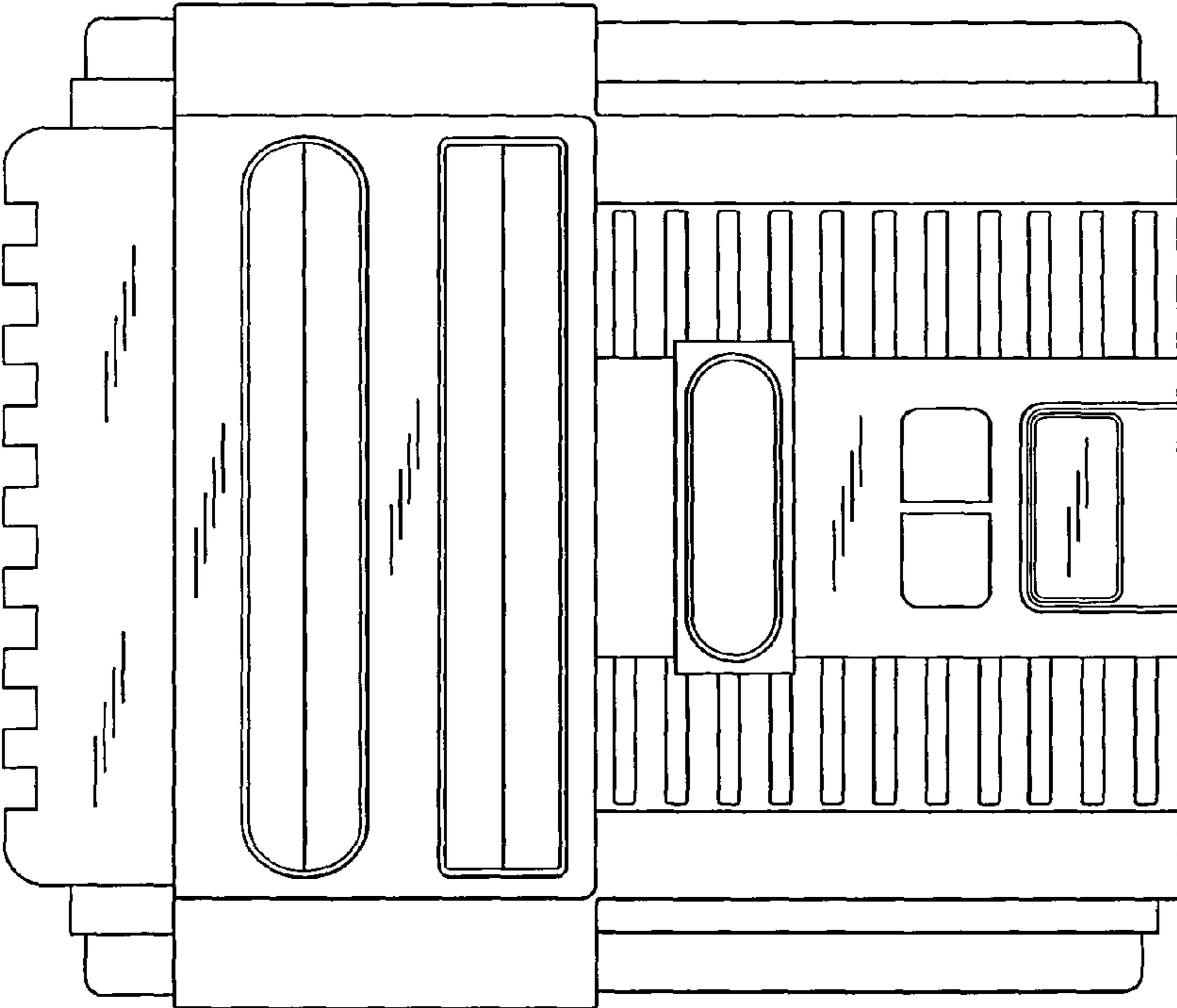

FIG.3

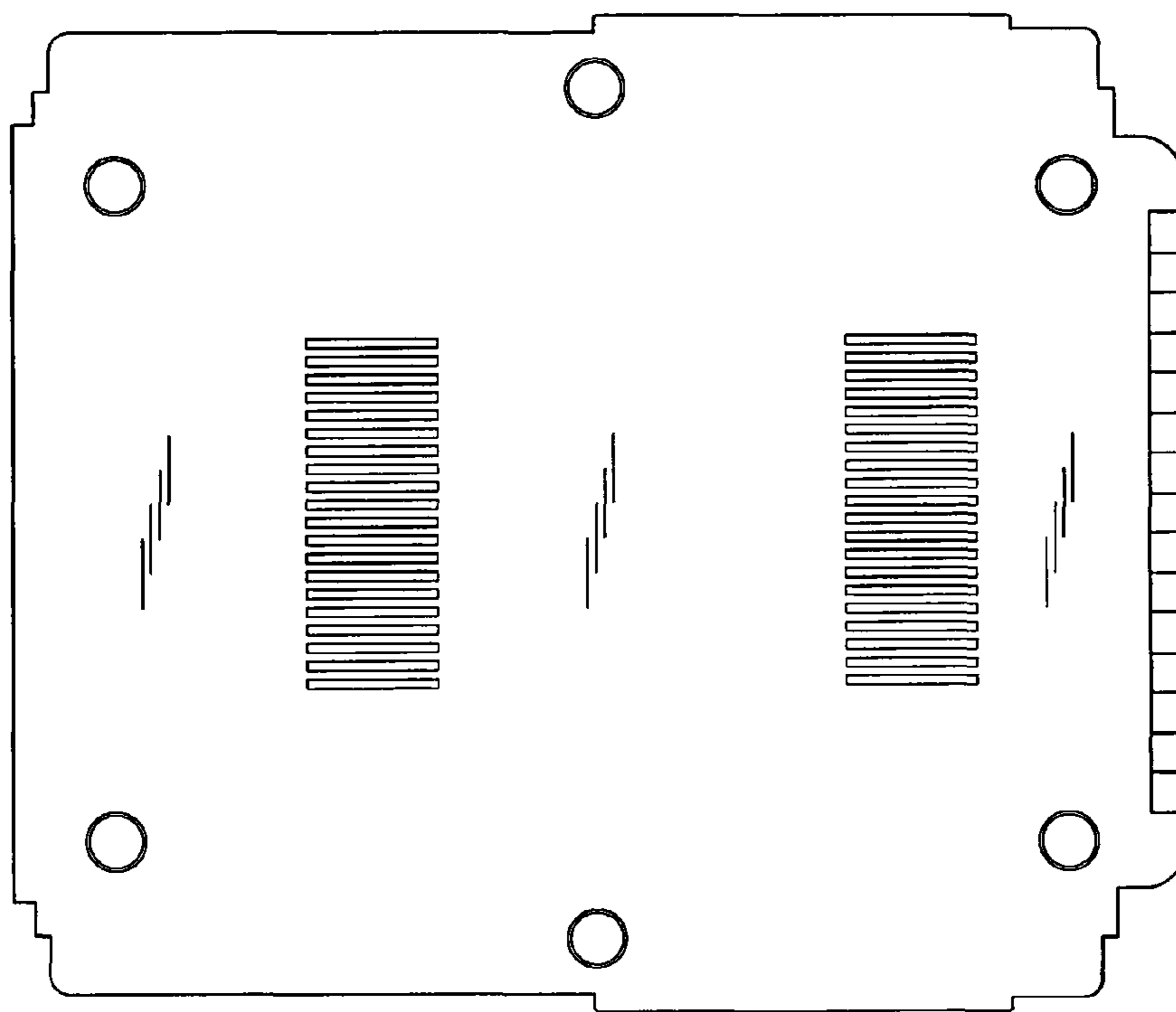

FIG.4

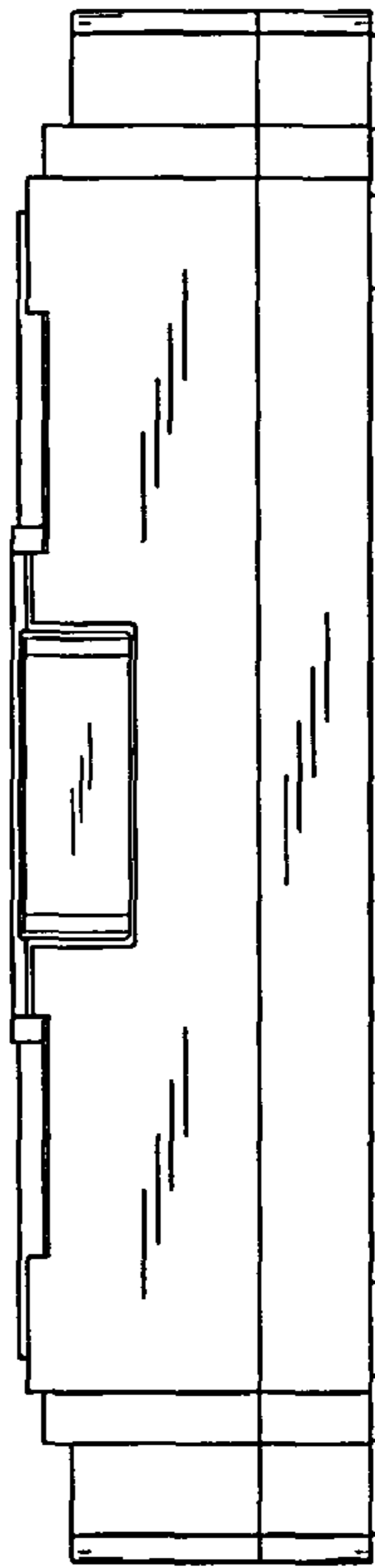

FIG.5

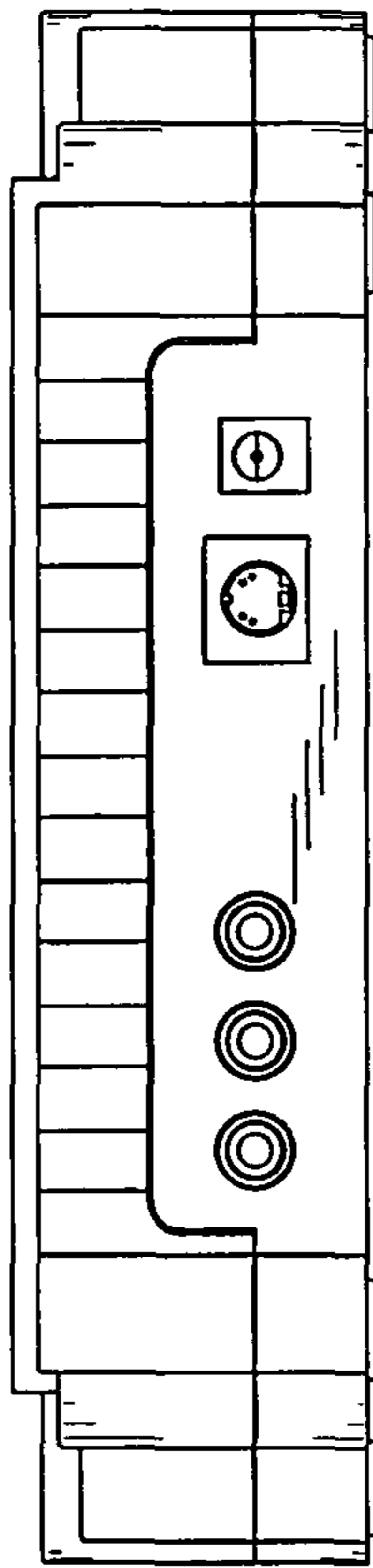

FIG.6

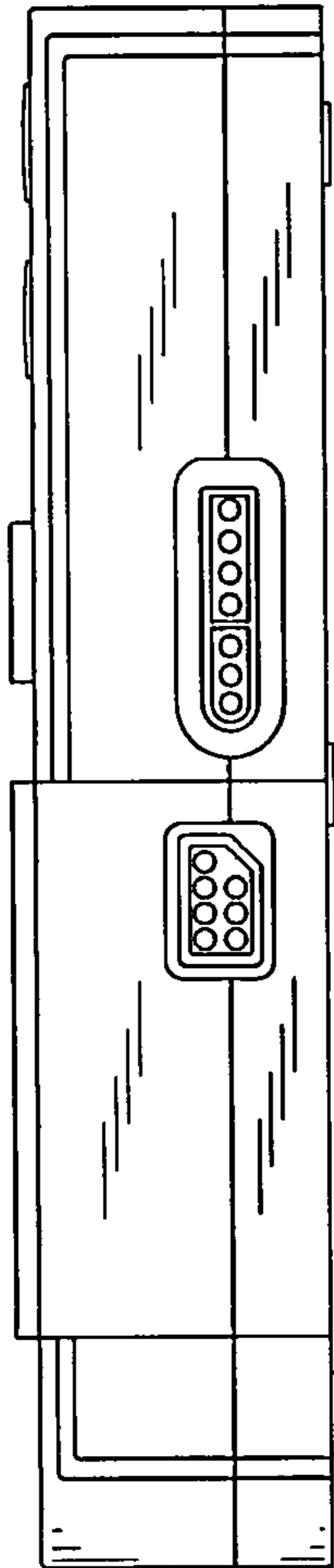

FIG.7

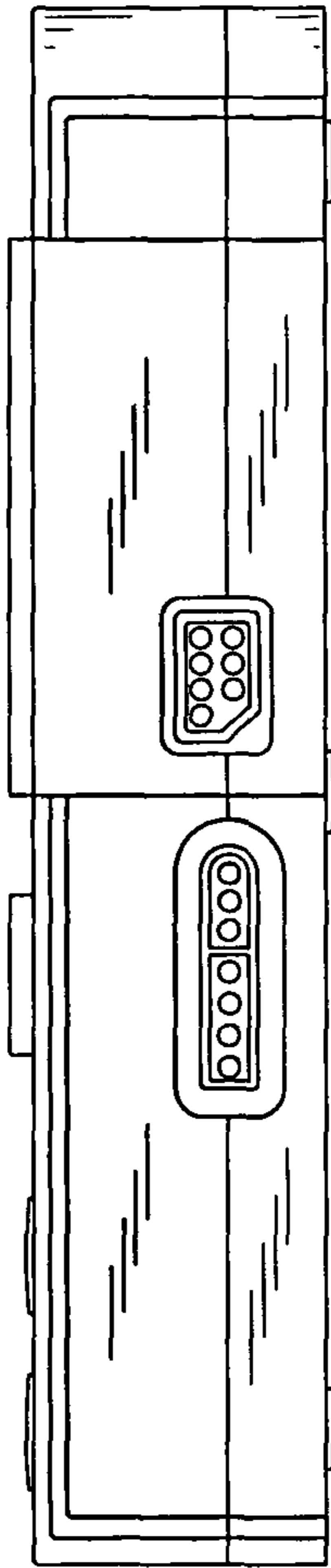

FIG.8