



US00D705269S

(12) **United States Design Patent**
Tachikawa et al.

(10) **Patent No.:** **US D705,269 S**

(45) **Date of Patent:** **** May 20, 2014**

(54) **CYLINDER HEAD FOR INTERNAL COMBUSTION ENGINES**

2012/0031355 A1* 2/2012 Romblom 123/58.1
2013/0055971 A1* 3/2013 Brewer et al. 123/41.82 R
2013/0133196 A1* 5/2013 Bach et al. 29/888.011

(71) Applicant: **Honda Motor Co., Ltd.**, Tokyo (JP)

* cited by examiner

(72) Inventors: **Takehisa Tachikawa**, Wako (JP);
Makoto Hamahara, Tokyo (JP)

Primary Examiner — T. Chase Nelson

Assistant Examiner — Ania Aman

(73) Assignee: **Honda Motor Co., Ltd.**, Tokyo (JP)

(74) *Attorney, Agent, or Firm* — Westerman, Hattori,
Daniels & Adrian, LLP

(**) Term: **14 Years**

(57) **CLAIM**
The ornamental design for a cylinder head for internal combustion engines, as shown and described.

(21) Appl. No.: **29/458,446**

DESCRIPTION

(22) Filed: **Jun. 19, 2013**

(30) **Foreign Application Priority Data**

Dec. 19, 2012 (JP) 2012-030986

(51) **LOC (10) Cl.** **15-01**

(52) **U.S. Cl.**
USPC **D15/5**

(58) **Field of Classification Search**
USPC D15/1-5; 123/193.2, 195 R, 196 R,
123/41.84, 41.74
See application file for complete search history.

FIG. 1: a front elevation view of the cylinder head for internal combustion engines;
FIG. 2: a rear elevation view of the cylinder head for internal combustion engines;
FIG. 3: a right side elevation view of the cylinder head for internal combustion engines;
FIG. 4: a left side elevation view of the cylinder head for internal combustion engines;
FIG. 5: a top plan view of the cylinder head for internal combustion engines;
FIG. 6: a bottom plan view of the cylinder head for internal combustion engines;
FIG. 7 is a front perspective view of the cylinder head for internal combustion engines as seen from the right upper side thereof;
FIG. 8 is a front perspective view of the cylinder head for internal combustion engines as seen from the left lower side;
FIG. 9 is a rear perspective view of the cylinder head for internal combustion engines as seen from the left upper side; and,
FIG. 10 is a rear perspective view of the cylinder head for internal combustion engines as seen from the right lower side.

(56) **References Cited**

U.S. PATENT DOCUMENTS

4,621,597 A * 11/1986 Kawada et al. 123/90.27
5,535,714 A * 7/1996 Aoyama et al. 123/193.5
5,775,272 A * 7/1998 Matsunaga et al. 123/41.82 R
6,408,808 B1 * 6/2002 Yi 123/90.27
6,561,153 B2 * 5/2003 Uchida 123/193.5
6,729,272 B2 * 5/2004 Iizuka et al. 123/41.84
6,840,221 B1 * 1/2005 Rowells et al. 123/456
7,367,294 B2 * 5/2008 Rozario et al. 123/41.82 R
D593,581 S * 6/2009 Sammons D15/5
2005/0133009 A1 * 6/2005 Rowells et al. 123/456

1 Claim, 10 Drawing Sheets

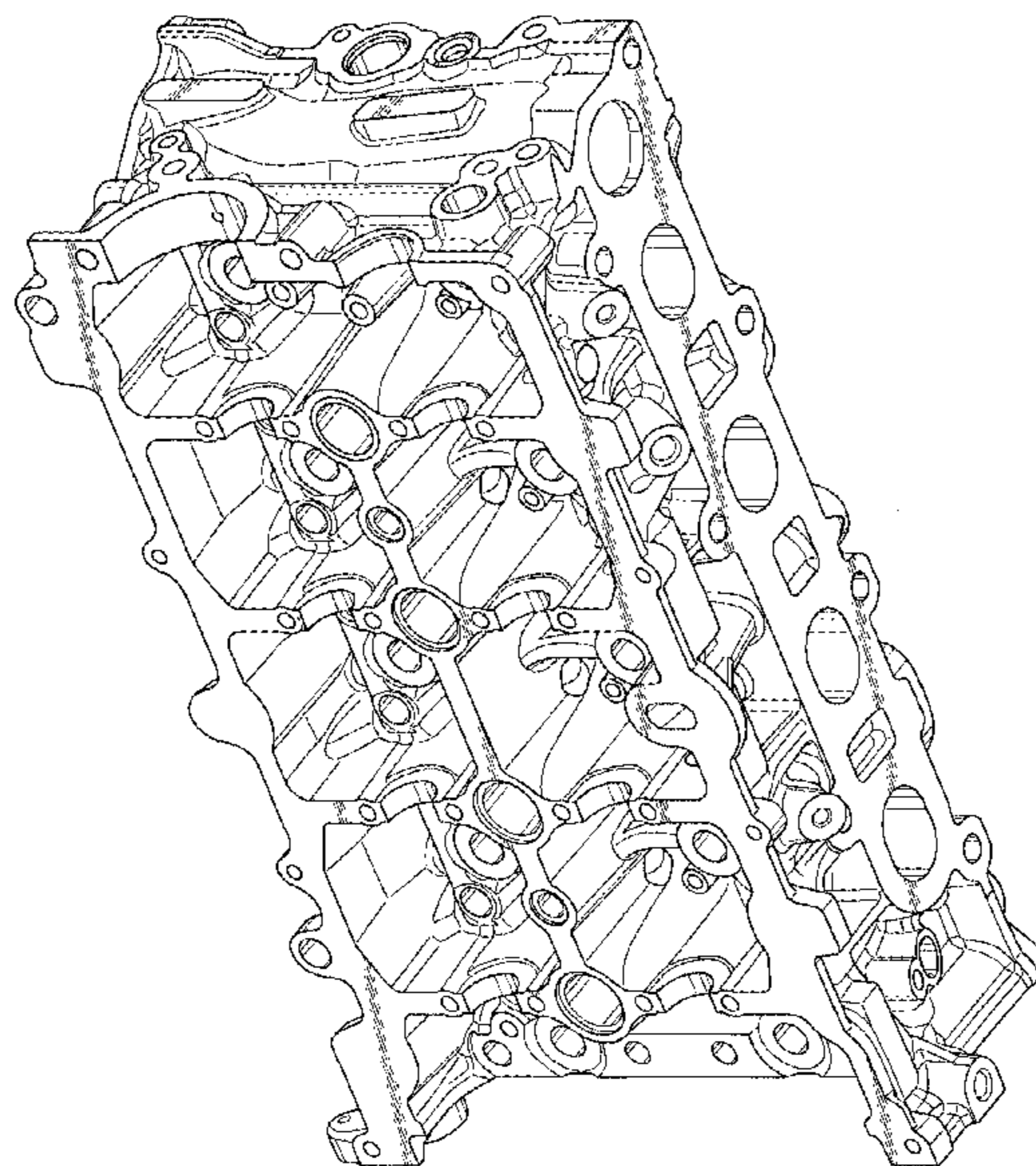

FIG.1

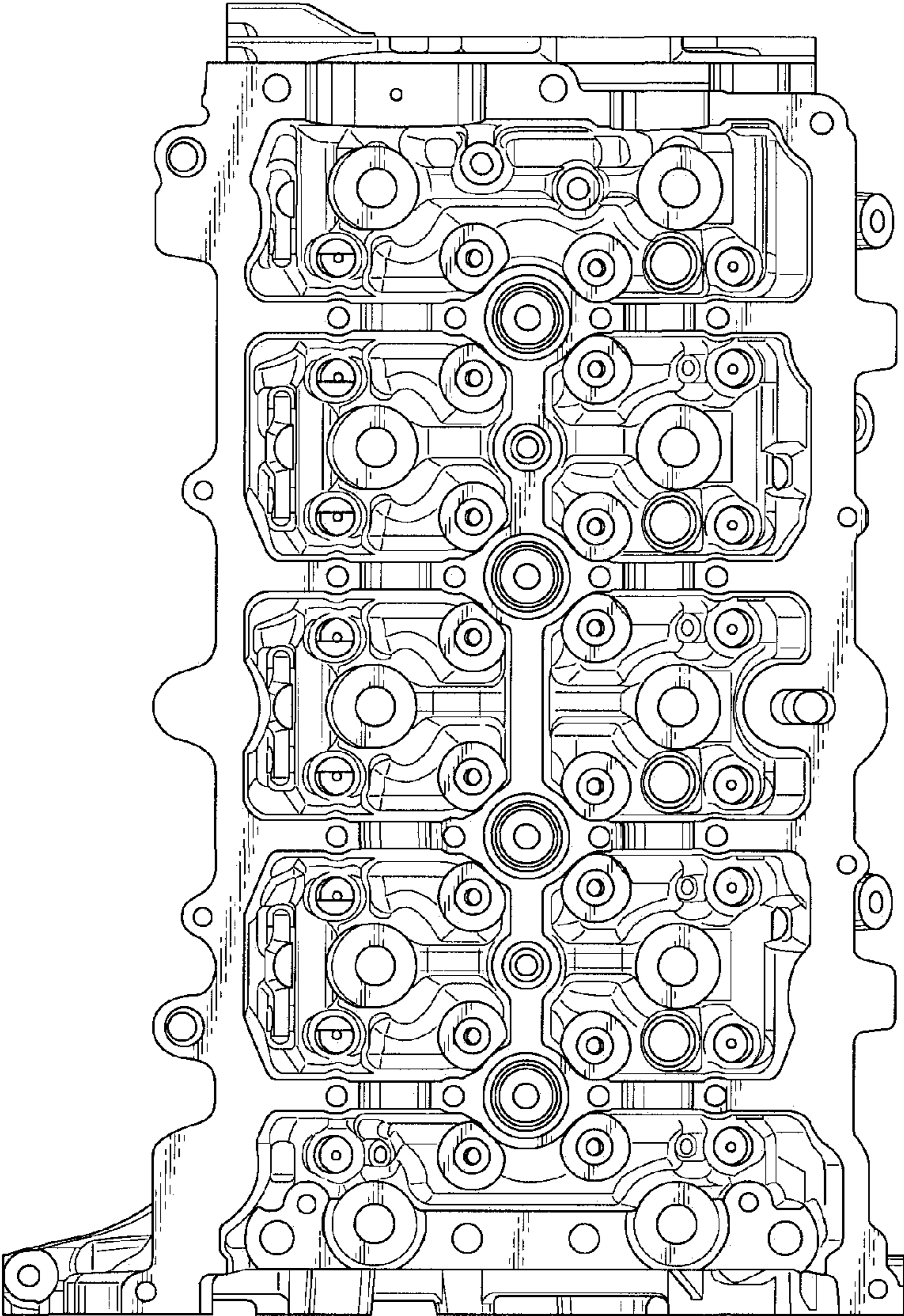

FIG.2

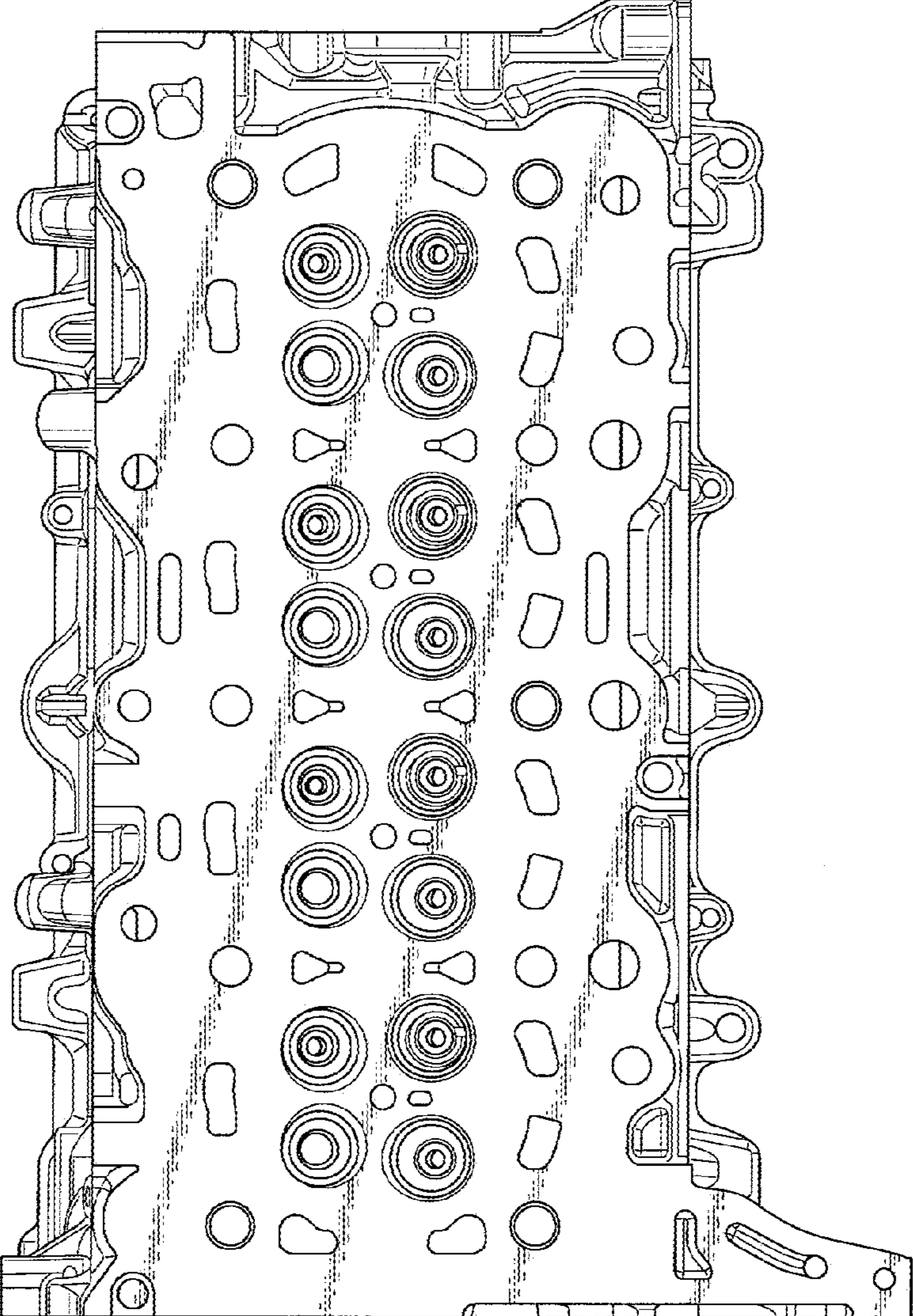

FIG.3

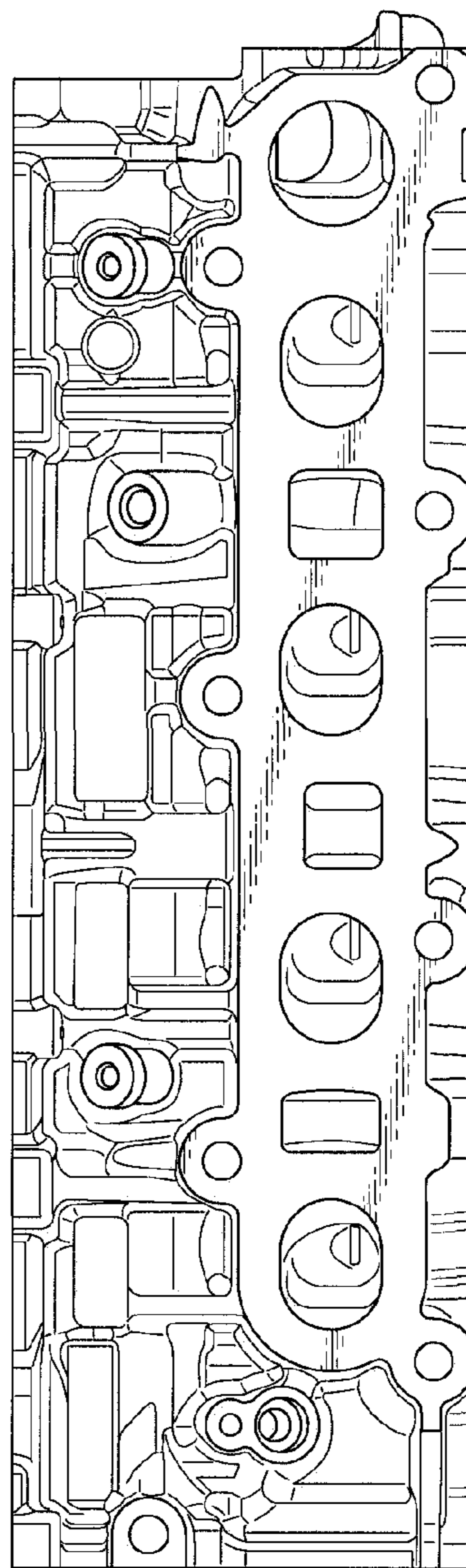

FIG.4

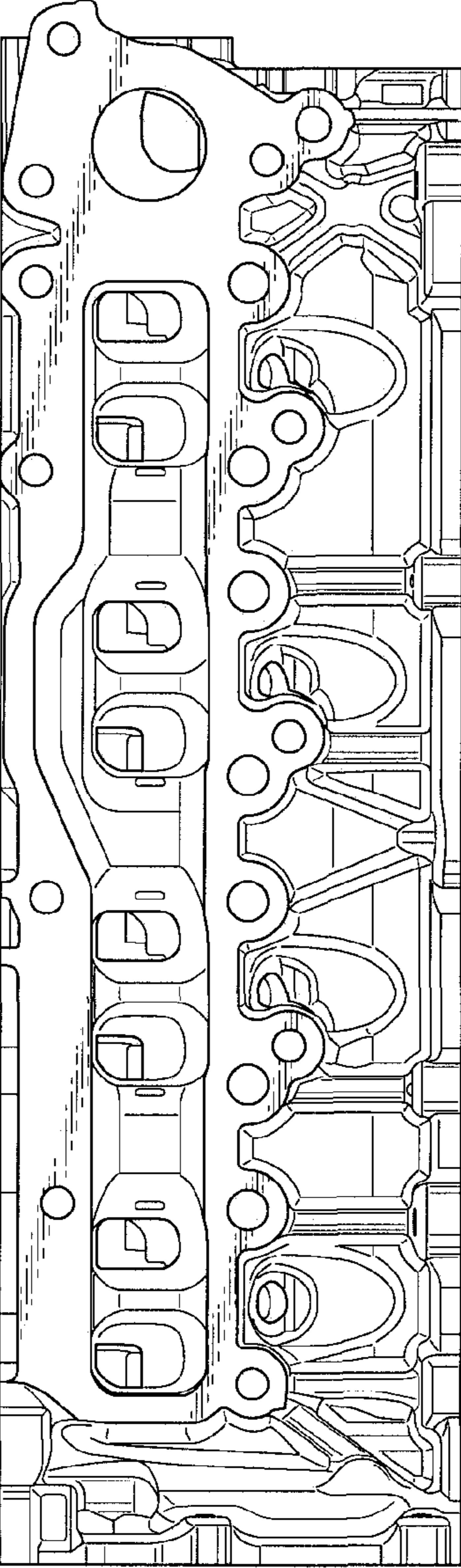

FIG.5

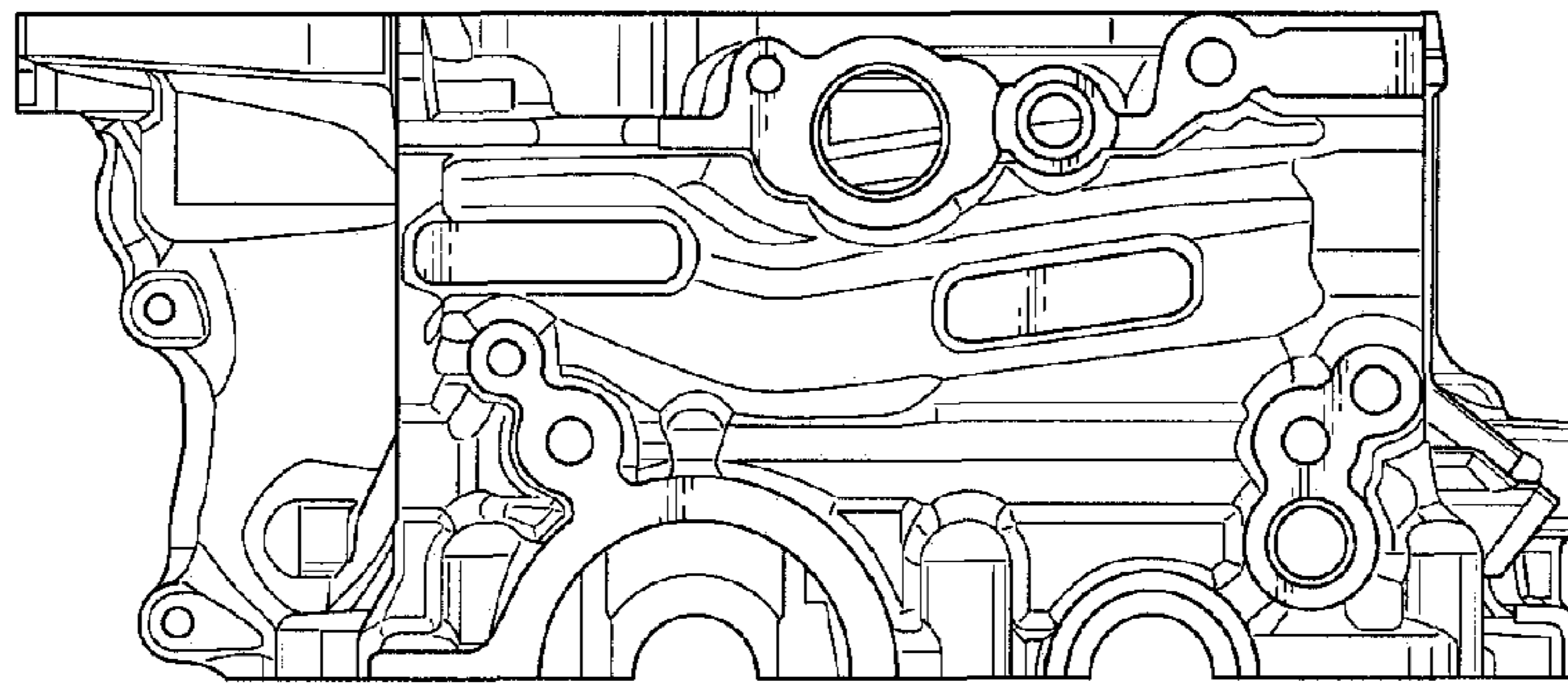

FIG.6

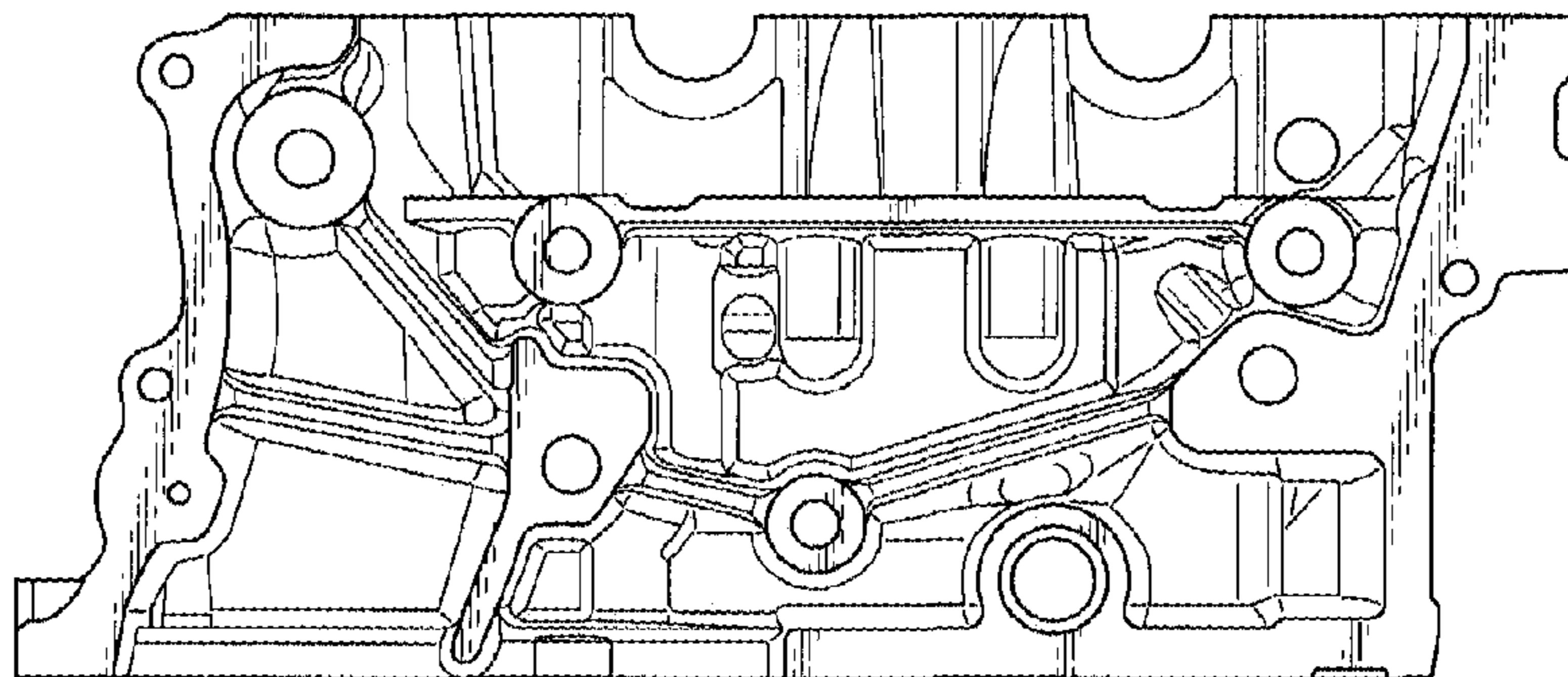

FIG.7

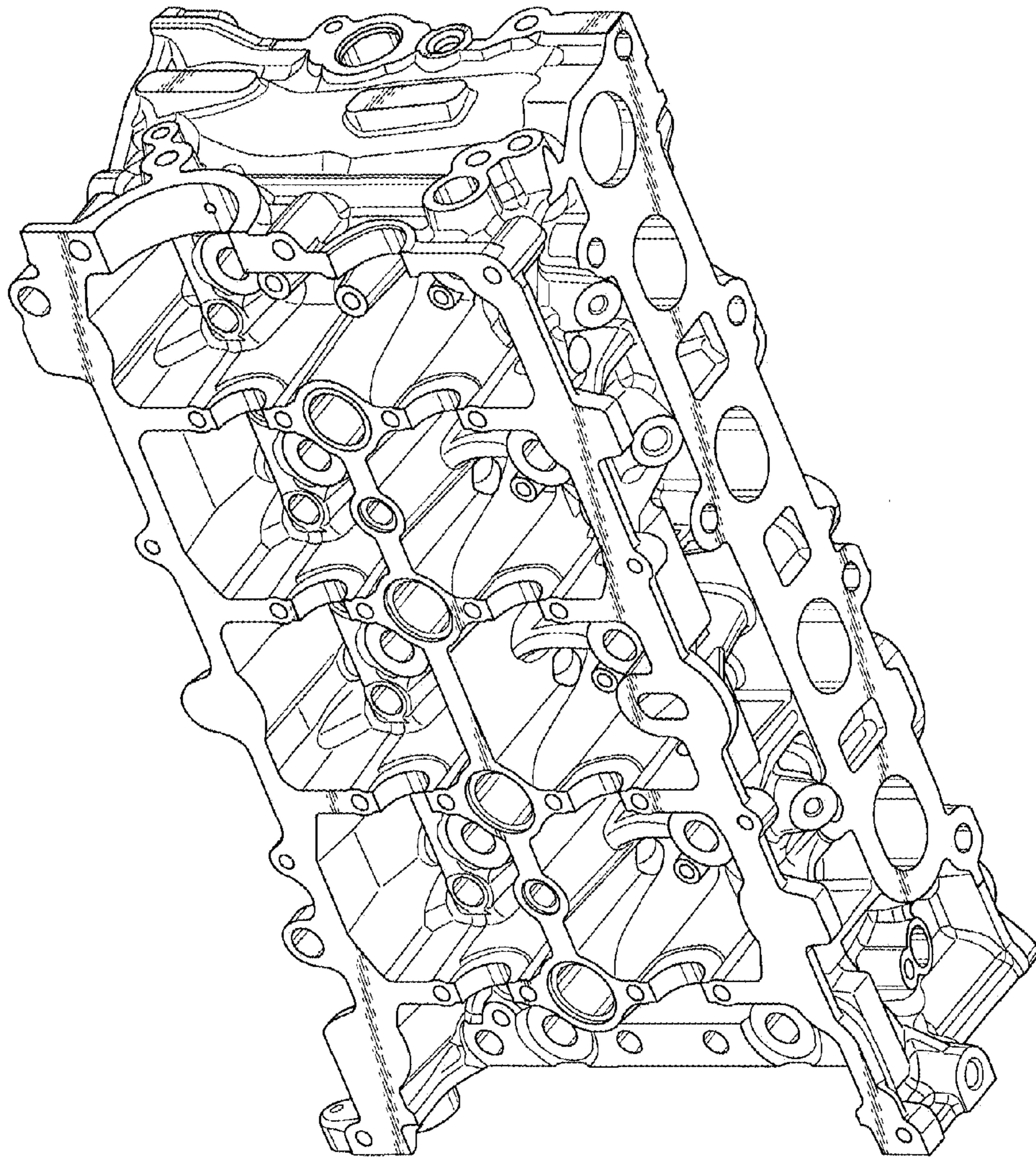

FIG.8

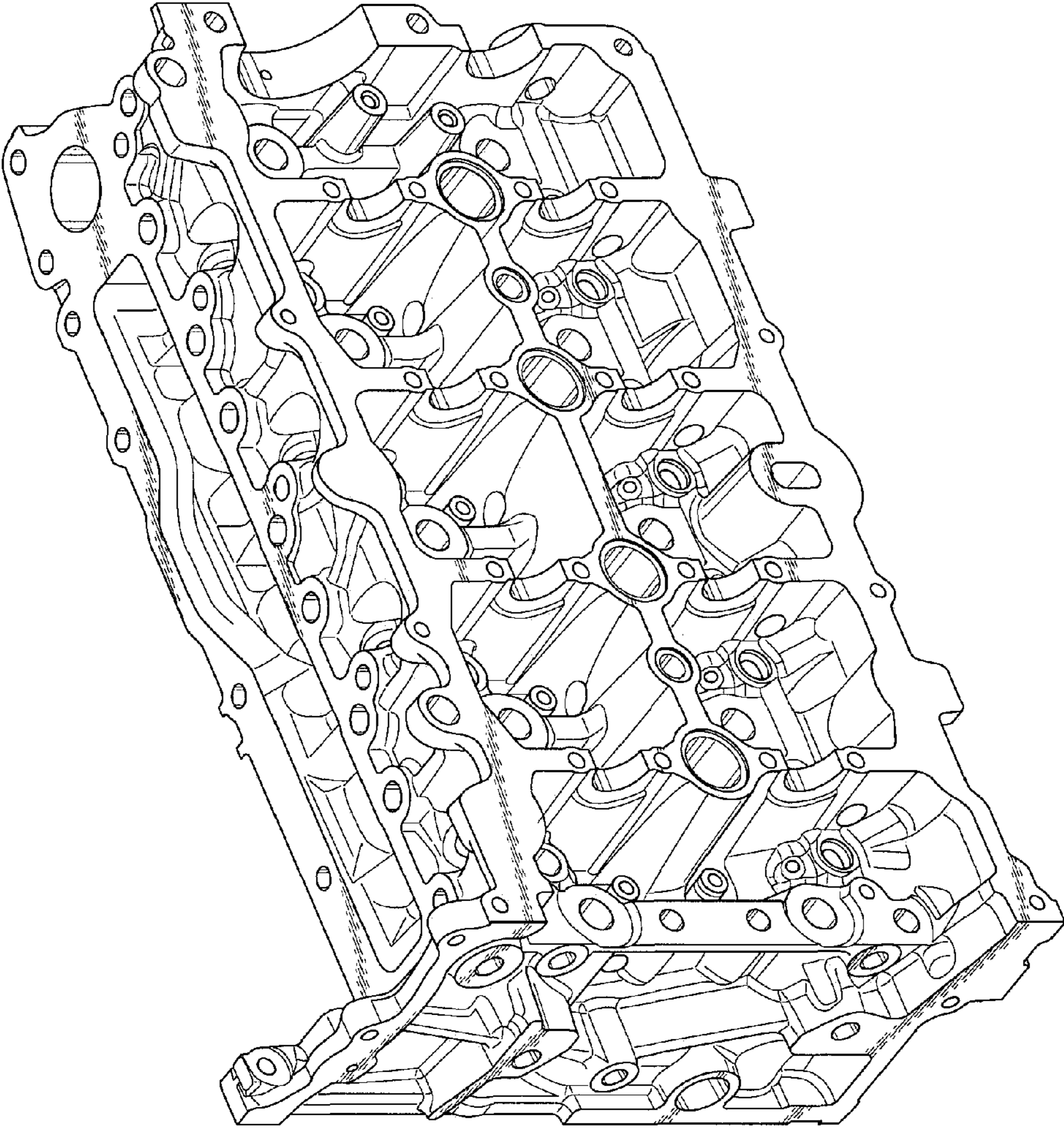

FIG.9

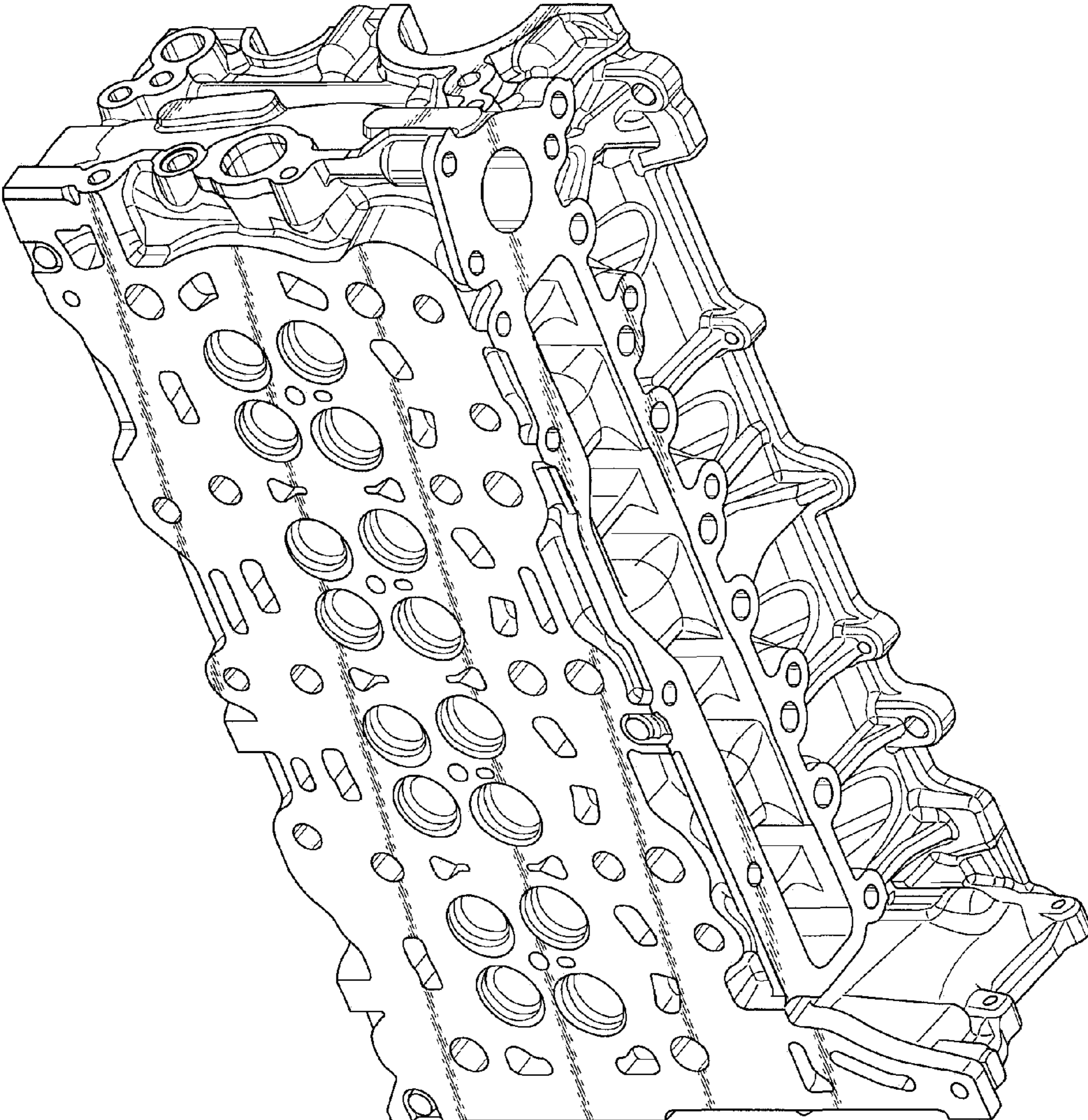

FIG.10

