



US00D705133S

(12) **United States Design Patent**
Pfaff

(10) **Patent No.:** **US D705,133 S**
(45) **Date of Patent:** **** May 20, 2014**

(54) **AERODYNAMIC DRAG REDUCTION
DEVICE FOR A TRAILER**

(71) Applicant: **Raimund Pfaff**, Carter Lake, IA (US)

(72) Inventor: **Raimund Pfaff**, Carter Lake, IA (US)

(**) Term: **14 Years**

(21) Appl. No.: **29/470,493**

(22) Filed: **Oct. 22, 2013**

(51) **LOC (10) Cl.** **12-10**

(52) **U.S. Cl.**
USPC **D12/106**

(58) **Field of Classification Search**
USPC D12/106, 19, 129, 100-105, 111-112;
D21/425, 435; D34/21-26, 12, 16-19;
280/204, 205, 63, 475, 482, 647;
296/168, 180, 180.02, 61, 10,
296/100.01-100.08

See application file for complete search history.

(56) **References Cited**

U.S. PATENT DOCUMENTS

4,629,241	A	12/1986	Gruich	
4,640,541	A	2/1987	FitzGerald et al.	
5,280,990	A	1/1994	Rinard	
6,974,178	B2	12/2005	Ortega et al.	
7,093,889	B2	8/2006	Graham	
7,578,541	B2	8/2009	Layfield et al.	
7,762,615	B2	7/2010	Dayton	
7,780,224	B2	8/2010	Roush	
7,789,453	B2 *	9/2010	Roush et al.	296/180.1
7,806,464	B2	10/2010	Cardolle	
7,828,368	B2	11/2010	Ortega et al.	
7,854,469	B2	12/2010	Dayton	

7,992,923	B2	8/2011	Dayton	
8,210,599	B2 *	7/2012	Butler	296/180.1
8,276,972	B2 *	10/2012	Domo et al.	296/180.1
8,322,778	B1 *	12/2012	Pfaff	296/180.4
8,376,450	B1 *	2/2013	Long et al.	296/180.4
2005/0146161	A1	7/2005	Uland	
2005/0161976	A1 *	7/2005	Ortega et al.	296/180.4
2008/0296930	A1 *	12/2008	Roush et al.	296/180.4
2008/0303309	A1	12/2008	Dayton	
2011/0068605	A1	3/2011	Domo et al.	
2011/0285167	A1 *	11/2011	Butler	296/180.1

* cited by examiner

Primary Examiner — Katrina A Betton

(74) *Attorney, Agent, or Firm* — Dennis L. Thomte; Thomte Patent Law Office LLC

(57) **CLAIM**

The ornamental design for an aerodynamic drag reduction device for a trailer, as shown.

DESCRIPTION

FIG. 1 is a front perspective view of the aerodynamic drag reduction device for a trailer of this invention;
 FIG. 2 is a top view of the aerodynamic drag reduction device for a trailer of this invention;
 FIG. 3 is a left side view of the aerodynamic drag reduction device for a trailer of this invention;
 FIG. 4 is front view of the aerodynamic drag reduction device for a trailer of this invention;
 FIG. 5 is a bottom view of the aerodynamic drag reduction device for a trailer of this invention;
 FIG. 6 is a right side view of the aerodynamic drag reduction device for a trailer of this invention; and,
 FIG. 7 is a rear view of the aerodynamic drag reduction device for a trailer of this invention.

1 Claim, 3 Drawing Sheets

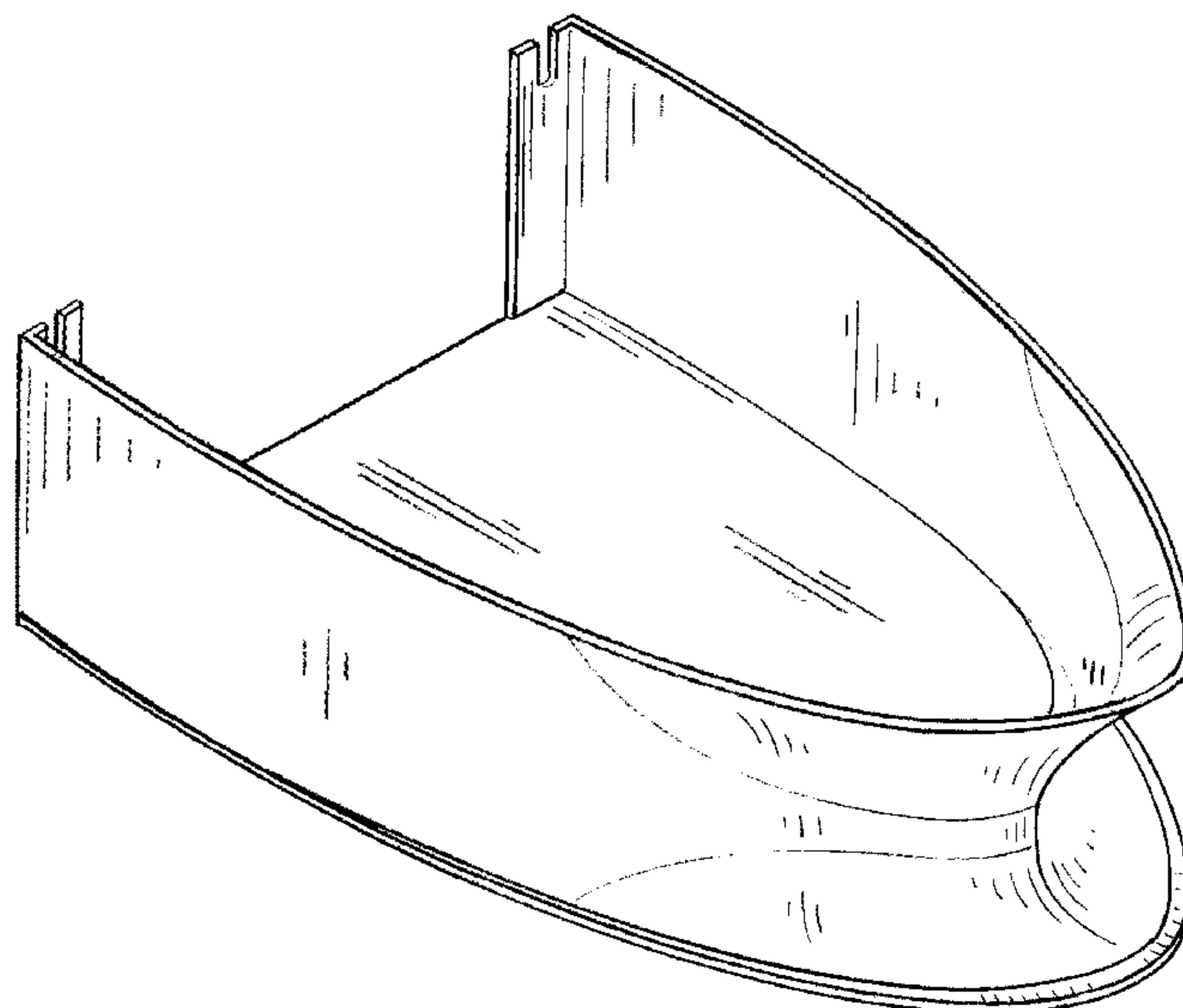

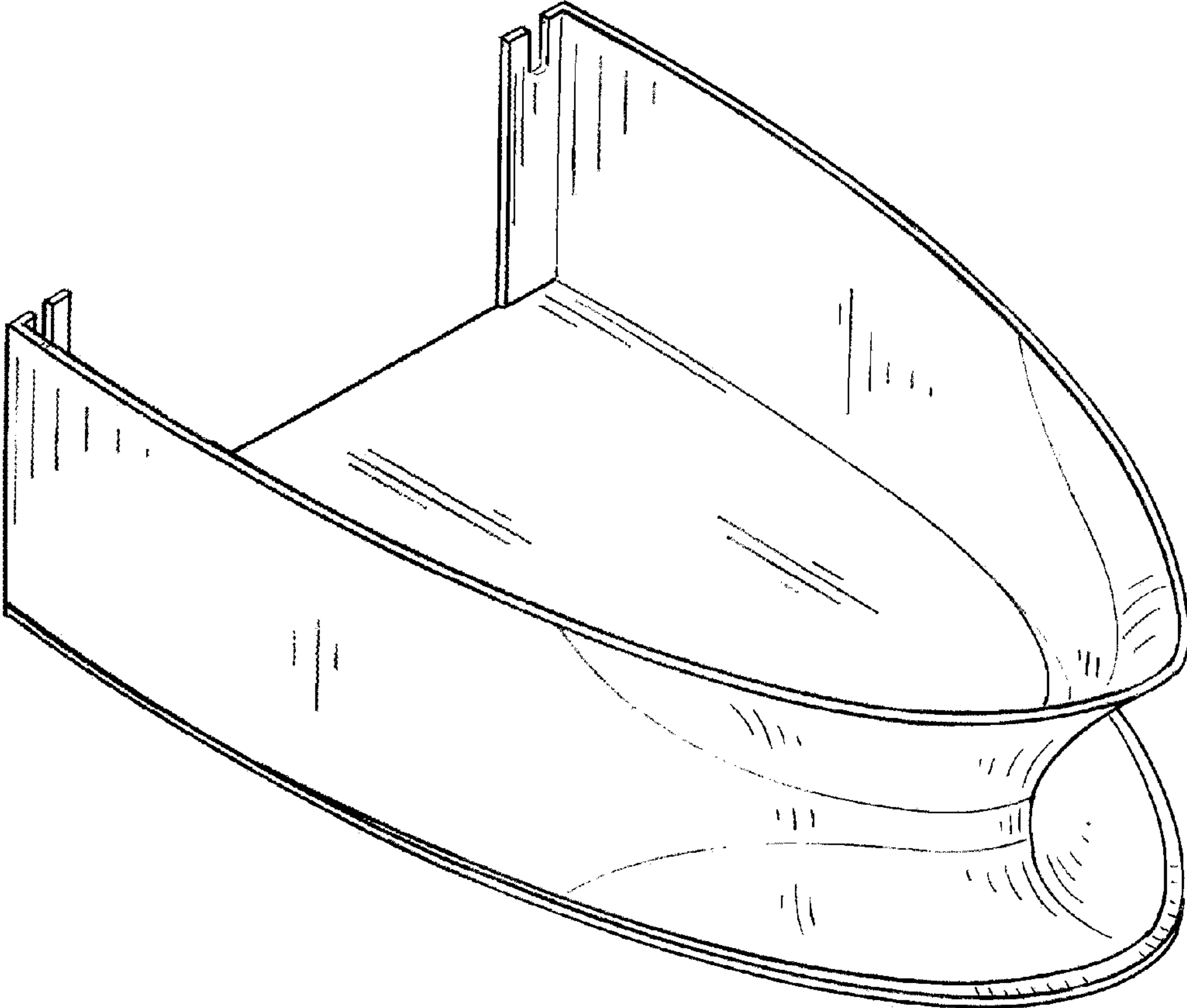

FIG. 1

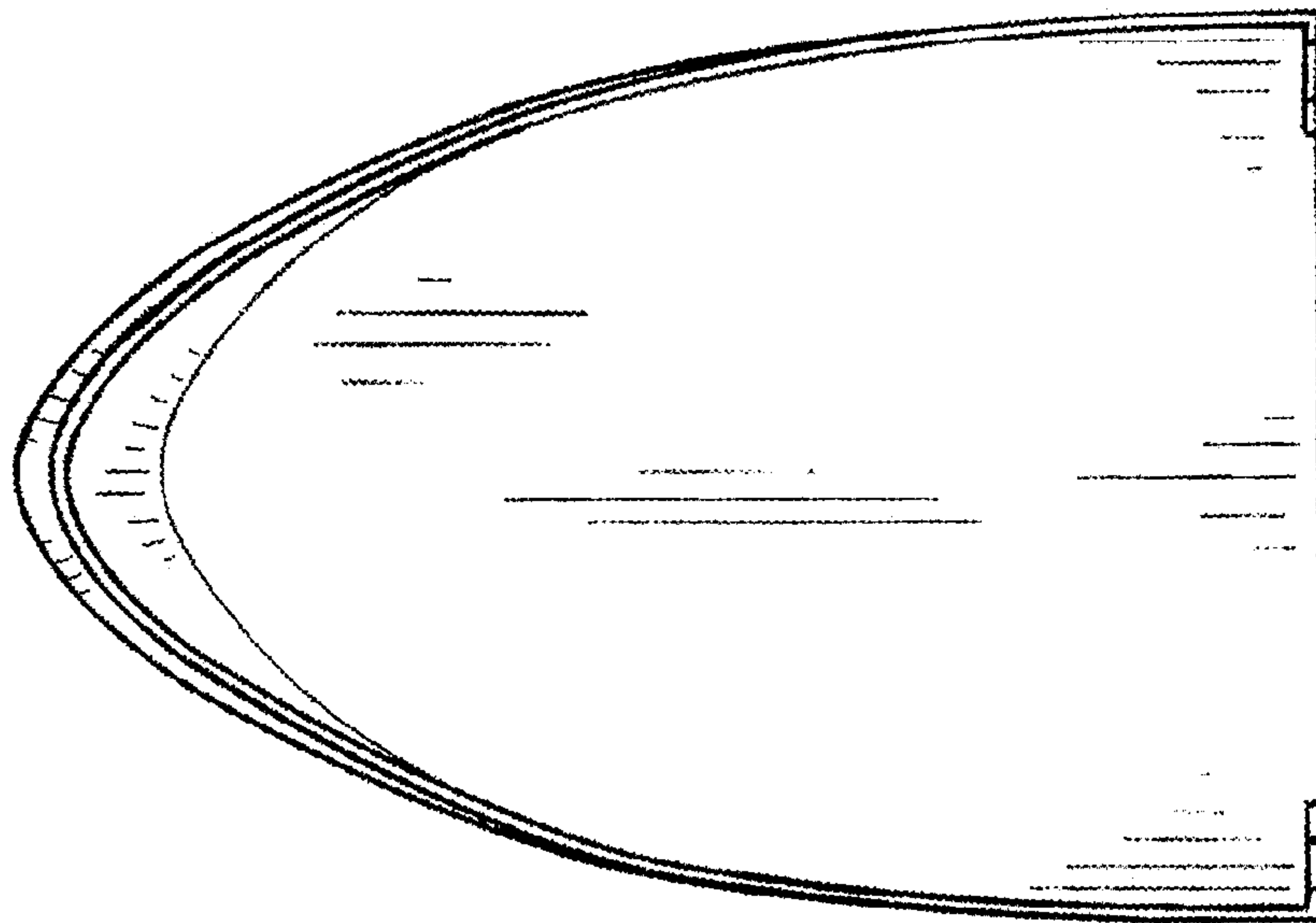

FIG. 2

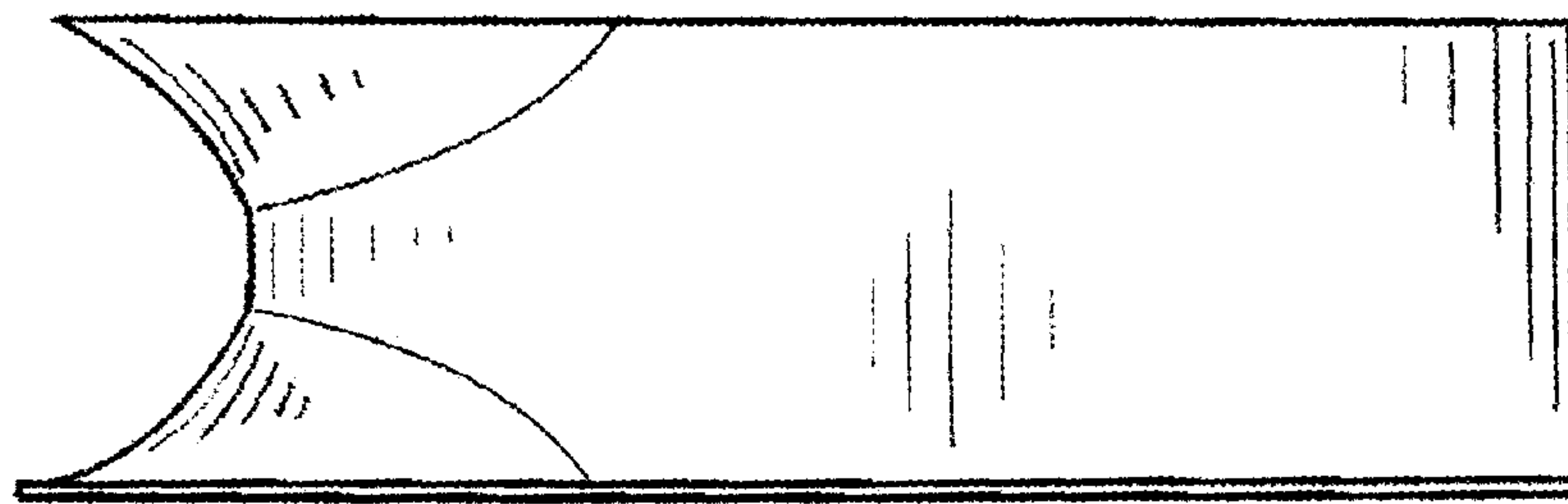

FIG. 3

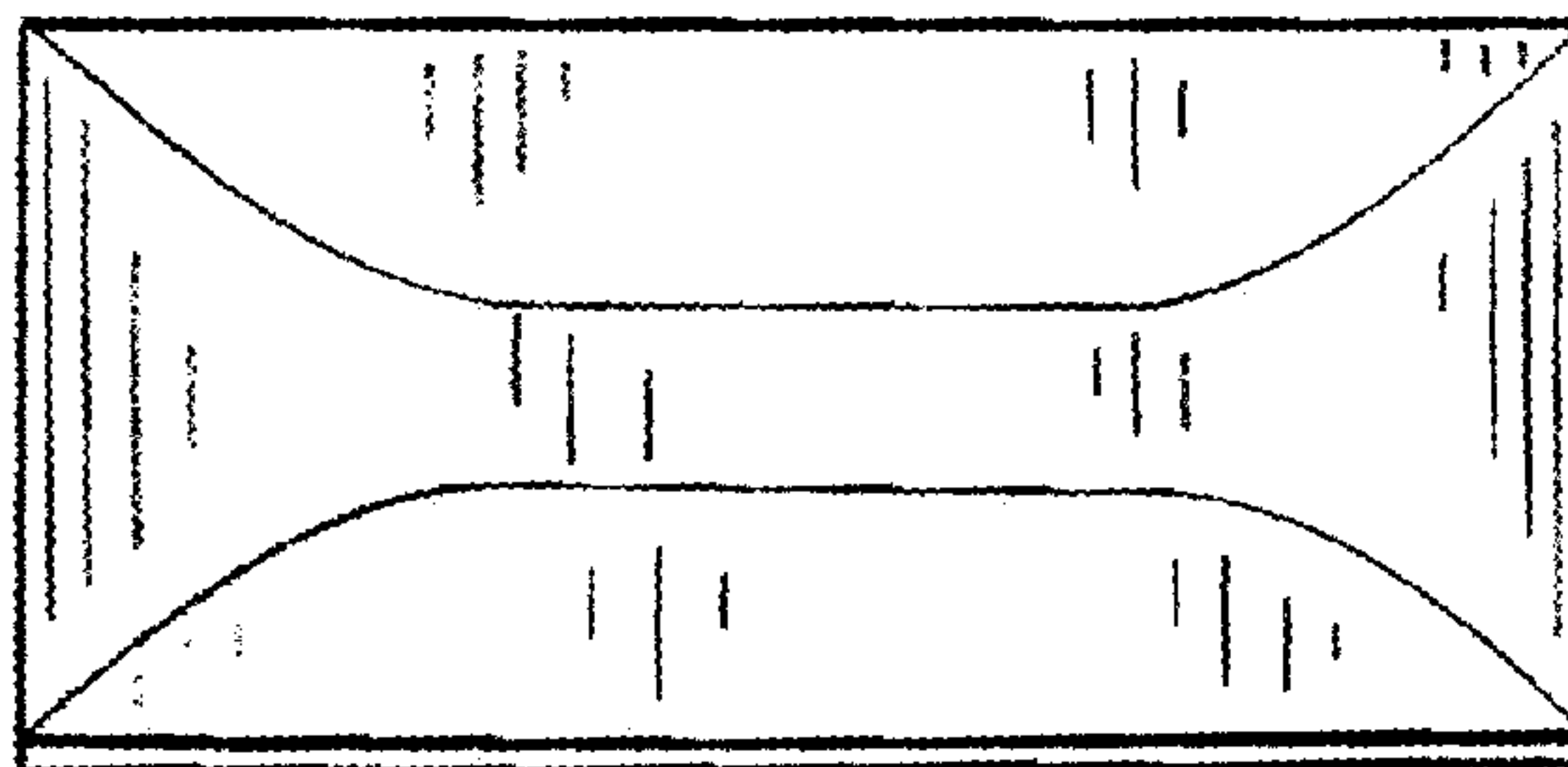

FIG. 4

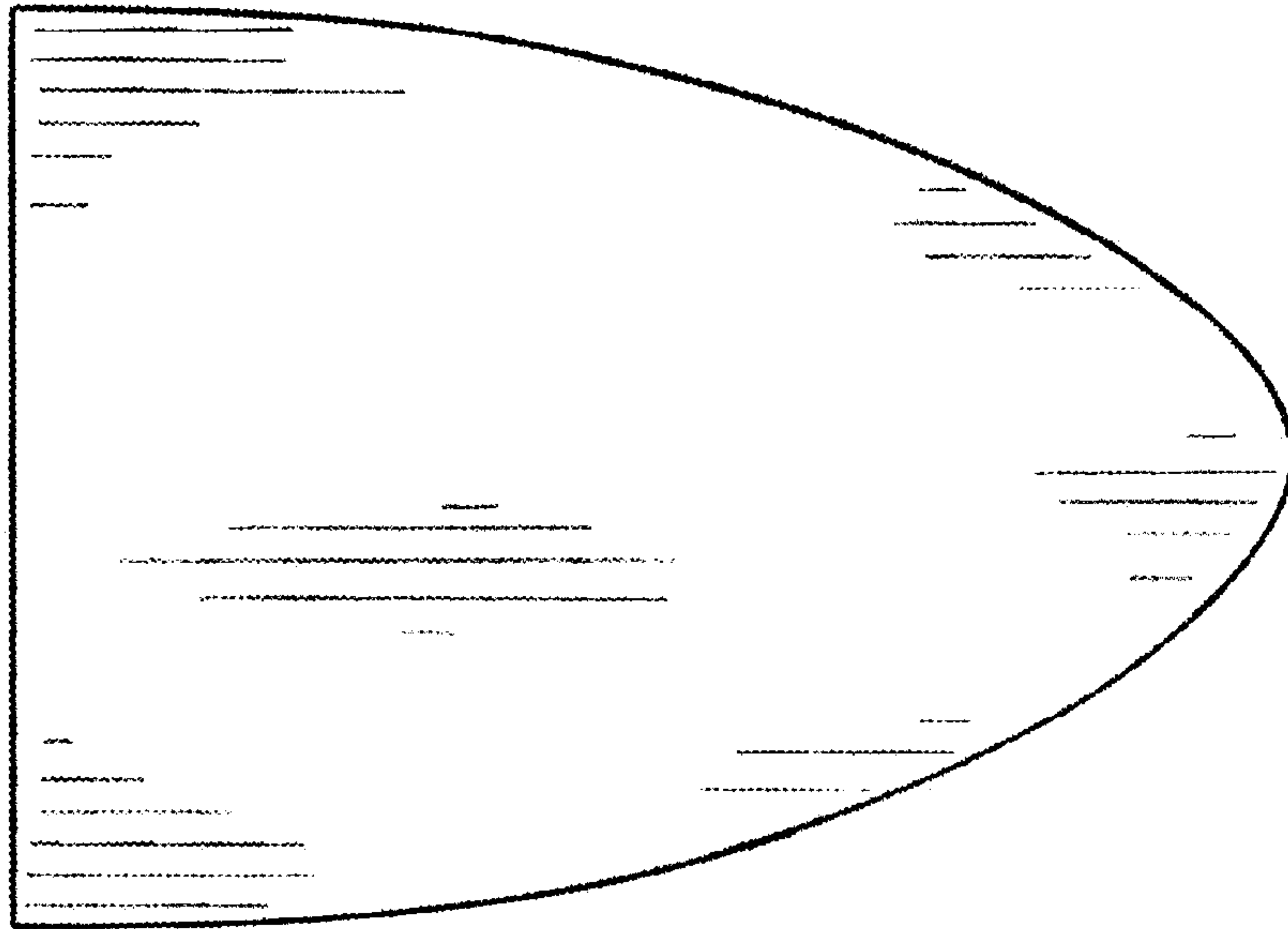

FIG. 5

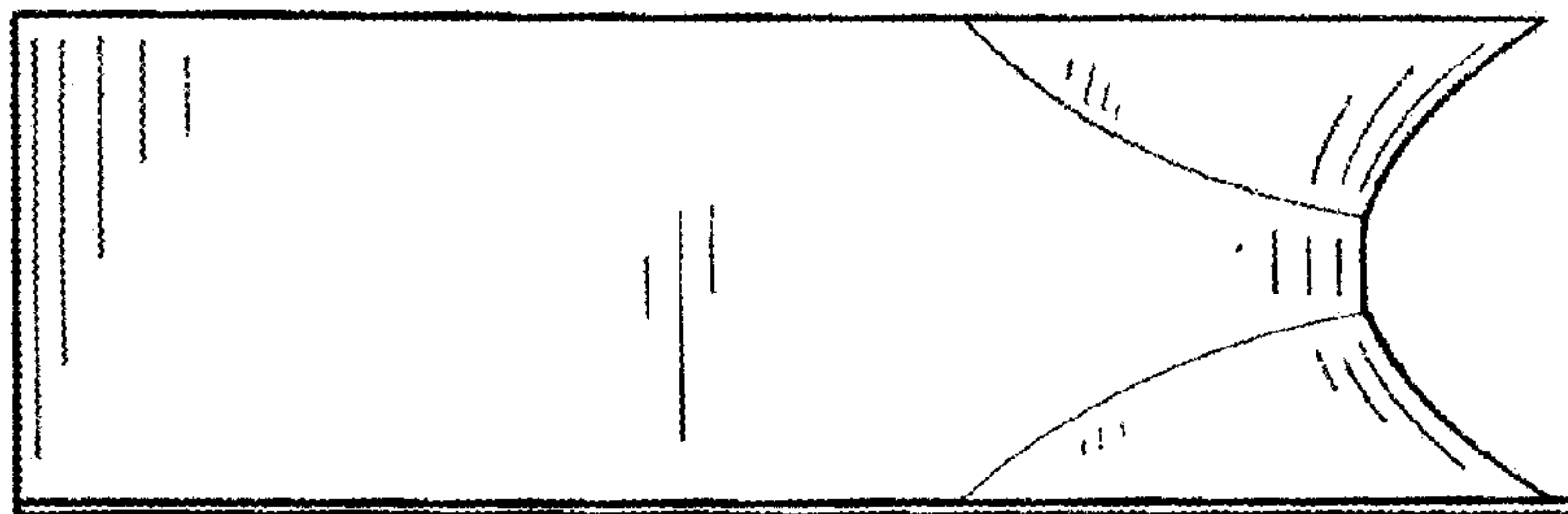

FIG. 6

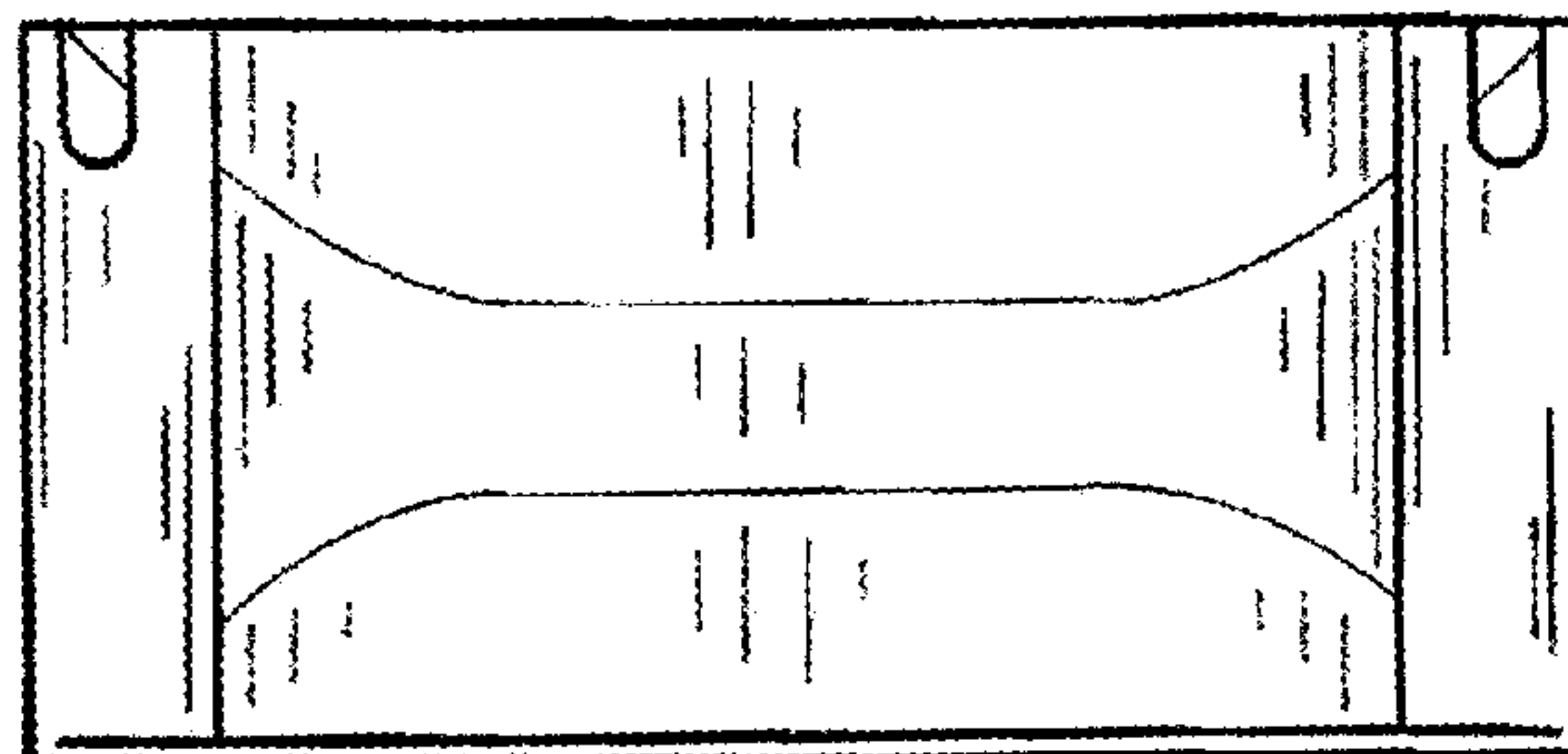

FIG. 7